

**ETHNIC AND RACIAL IDENTITY  
IN NORWEGIAN HIGHER EDUCATION:  
A CLASSROOM  
DISCOURSE ANALYSIS**

Joshua Domnick Dickstein

Department of Health Promotion and Development  
Faculty of Psychology  
University of Bergen



Master thesis submitted in partial fulfilment of the requirements for the degree

Master of Philosophy in Health Promotion

University of Bergen, 2014

## DECLARATION OF ORIGINALITY

I hereby declare that this thesis is of my own work and that, to the best of my knowledge, it contains no material previously published, or substantially overlapping with material submitted for the award of any other degree at any institution, except where due acknowledgement is made in the text.

Josh Dickstein

Bergen, November 20<sup>th</sup> 2014

## Acknowledgements

I was introduced to this fascinating avenue of research by my advisor, Yael Harlap. In particular, I thank her for making an extended effort to instil in me the level of commitment and dedication required to approach this topic.

The educative process in connection with developing this thesis represented an exponential learning curve that brought me from a contextual naiveté to a thorough curiosity and ultimately passionate concern.

I would like to thank Maurice Mittelmark for his direct sense of humor, realistic insights and confirmation that this thesis addressed issues central to the principles of health promotion.

To my professors Torill Bull, Elisabeth Fosse and Marguerite Daniel, thank you for your unique ways of educating the optimistic field of health promotion.

I would like to thank my Norwegian friends for their informative discussions and candidly presenting their views.

I would like to thank my parents for their patience and unwavering support. I am grateful to my mother for raising her children with sensitivity to fairness. I thank my father for our long discussions exploring the topics as well as encouragement to embrace the scope of my project.

Because of my background as the son of an American Jew and white South African, I have become sensitised to institutionalised injustice. I am and will always be grateful for that.

To my brother, who was there for me whether I needed formatting aid or a distraction.

I thank my grandmother for reminding me of the courage of honesty, complexity of identity and that there are always two sides to every story.

I thank the participants, including the professors and students for their willingness to have frank discussion while being audio-recorded.

Finally, I thank the University of Bergen's faculty of psychology, in particular, Ellen Meyer Hoff for her assistance and support.

# Table of Contents

<b>Abstract</b> .....	V
<b>1. Introduction</b> .....	1
1.1 Relevance of this thesis to Health Promotion .....	1
1.2 Racialisation and Racism .....	2
1.3 The Importance of Ethnicity to Norwegian Identity .....	3
1.4 Purpose .....	4
1.5 Objectives & Research Questions .....	5
<b>2. Literature Review</b> .....	6
<b>3. Theoretical Framework</b> .....	13
3.1 Critical Race Theory .....	13
3.2 Biological vs. Cultural Essentialism .....	14
3.3 Colourblindness .....	15
3.4 Civilised vs. Savage .....	18
3.5 White Privilege .....	20
3.6 Likhet (Imagined Sameness) .....	22
3.7 Interest Convergence .....	23
<b>4. Data and Methods</b> .....	24
4.1 Protocol .....	24
4.2 Data Collection .....	25
4.3 Collecting Information .....	26
4.4 Observations and Reflections .....	27
4.5 Discourse Analysis .....	29
4.6 Discursive Psychology .....	29
4.7 Discursive Psychology and Race .....	30
4.8 Unit of Analysis .....	30
4.9 Course Selection .....	32
4.10 Validity, Reliability and Generalizability of the Findings .....	33
4.11 Role of Researcher .....	35
4.12 Ethical Considerations .....	38
<b>5. Findings</b> .....	39
1. 'Whiteness' .....	40
2. Norwegian Ethnicity .....	45
3. The Racialised 'Other' .....	68
<b>6. Discussion</b> .....	77
6.1 Interpreting the findings in terms of the theoretical framework .....	78
6.2 How racial issues are discussed in classroom discourse .....	80
6.3 Racial discourse in the two different learning settings: Lectures and Colloquia .....	83
6.4 Expert vs. interactive learning based environments .....	83
6.5 The impact of racism in Norway .....	85
6.6 Limitations .....	89
<b>7. Conclusion</b> .....	91
<b>8. References</b> .....	92
Appendix A .....	98
Appendix B .....	100
Appendix C .....	104
Appendix D .....	105

## Abstract

The increase in foreign immigration into Norway during the last two decades has led to a progressive transition from a homogenous population to a multicultural environment.

Traditionally, Norwegian culture places emphasis on identity as defined by ethnicity and therefore, the potential for stigmatised racialisation of immigrants exists. This may serve to marginalise individuals and impede achievement of the essential principles of health promotion. This study employed the methodology of discourse analysis to assist in the interpretation of individual attitudes relating to issues such as race, ethnicity, nationalism, identity, belongingness, inclusion and exclusion.

Discourse analysis is the critical examination of both spoken and written communication. Interpretive repertoires are identified, which facilitate understanding within the cultural context. Two lectures and two colloquia at the bachelor level at the University of Bergen were audio-recorded. The eight hours of data were subsequently transcribed, coded and analysed in Norwegian before being discussed in English.

Analysis of the classroom discourse indicates that ethnic origin and 'whiteness' appear to represent essential concepts to ethnic Norwegians. Understanding this concept is crucial in interpreting discourse related to race and racialisation. A close relationship between biological factors and Norwegian national/cultural belonging was identified. White privilege may promote a host vs. guest attitude where the 'us' and 'we' characterise the ethnic Norwegian's view of Norway as a white space.

Discourse analysis of Norwegian bachelor-level classroom discussions revealed that ethnicity and race represent a central theme in understanding Norwegian attitudes related to the challenges associated with immigration and the transition into a multicultural society.

# 1. Introduction

This thesis explores how bachelor-level students, through discourse in Norwegian classroom settings, talk about or around the concept of race and ethnic identity. Race refers to “human populations...divided into sub-species mainly on the basis of visible physical characteristics,” including skin-colour (Bhopal, 2004). Personal and social identity is constructed by “sharing common beliefs, values and norms which have been developed by the community in the past and may be modified in the future,” (Nutbeam, 1998, p. 354). This study employed the methodology of discourse analysis to assist in the interpretation of individual attitudes relating to issues such as race, ethnicity, nationalism, identity, belongingness, inclusion and exclusion.

## **1.1 Relevance of this Thesis to Health Promotion**

In 1986, The Ottawa Charter under the World Health Organization defined health promotion as “the process of enabling people to increase control over and to improve their health. To reach a state of complete physical, mental and social well-being, an individual or group must be able to identify and to realise aspirations, to satisfy needs, and to change or cope with the environment,” (WHO, 1986).

Norwegian culture and attitudes typically place emphasis on an individual’s ethnicity and the potential for stigmatised racialisation of ‘foreigners’ exists (Wiggen, 2012). This may serve to marginalise individuals and impede “achievement of the essential principles of health promotion,” (WHO, 1986). Whether intentional or otherwise, disenfranchising a group of people and placing them at a disadvantage based on their race represents a tangible obstacle to achieving the essential criteria for health promotion.

“In the end, health promotion is about ensuring people have the power to make healthy choices. This power comes not only from knowledge about health issues but also from having equal access to economic and political resources. Effective health promotion, therefore, must include initiatives that aim at breaking down the systemic barriers faced by ethnocultural communities in all sectors of society,” (CAMH, 2012).

## **1.2 Racialisation and Racism**

Racialisation is a social construction and the process by which groups and individuals come to be identified by a racial category (such as Black, Asian and Caucasian, etc.) (Brah, 1991).

Though many of the biological concepts of race have been discredited, the social construction and stigmatisation of racialisation remains a vigorous and powerful influence in society, not only inhibiting progress towards social equality, but also impeding achievement of the essential principles of health promotion. This is a fundamental issue in that empowerment implies having sufficient access to available resources and being able to exert control over one’s mental, physical and social health (Nutbeam, 1998).

The US Civil Rights Commission refers to racism as “any action or attitude, conscious or unconscious, that subordinates an individual or group based on skin-colour or race. It can be enacted individually or institutionally.” Although there is a close interplay between institutional and individual racism, a distinction should be made. Institutional racism is “a system of procedures/patterns in all walks of life, i.e. politics, education, housing, businesses, employment, professional associations, religion, media, etc., whose effect is to perpetuate and maintain the power, influence and well-being of one group over another,” (SASC, 2013).

Racism legitimised on the institutional level may be less apparent than individual racism, receiving less media attention and public criticism.

In an example of institutional racism, Thomas P. Bonczar and Allen J. Beck (1997) outlined that there was a significant racial disparity in U.S. prisons according to the cumulative percentage of incarcerated males. The statistics indicated “At current levels of incarceration a black male in the United States today has greater than a 1 in 4 chance of going to prison during his lifetime, while a Hispanic male has a 1 in 6 chance and a white male has a 1 in 23 chance of serving time,” (Beck & Bonczar, 1997). This proportion does not reflect the difference in crime rates between these racial groups, because “5 times as many Whites are using drugs as African Americans, yet African Americans are sent to prison for drug offenses at 10 times the rate of Whites,” (NAACP, 2014). This example demonstrates that institutional racism has a potential to be more destructive than individual racism due to its perceived credibility, reduced accountability and systematised ‘legal’ framework.

### **1.3 The Importance of Ethnicity to Norwegian Identity**

Ethnic Norwegians appear to have a ‘symbiotic’ relationship with Norway’s physical geographic space. This may be because by definition ethnic Norwegians have an ethnic origin in Norway and thus feel entitled to a sense of belonging and ownership. The Norwegian language also has the potential to reveal bias within the Norwegian culture.

For example, let’s consider the Norwegian spoken language concerning immigration (Phelps & Nadim, 2010) and the integration or assimilation of immigrants (Hagelund, 2002). The term ‘immigrant’ [*innvandrere*] is commonly reserved only for the racialised non-ethnic Norwegians living in Norway (Hernes & Knudsen, 1990), and as such, the language could be viewed as racially coded. During the last decade, there has been more research exploring how language was employed in racial discourse as well as investigating how race-related issues such as immigration and nationalism, are constructed by white, ethnic Norwegians (Berg, 2008).



## **1.4 Purpose**

There has been a rapid and substantial increase in foreign immigration during the last two decades. In 1992, the population of immigrants and Norwegian citizens born to immigrant parents was 4.3%. In 2011, it was 13.1%, which accounted for most of the population growth that year. This represents more than a three-fold increase in fewer than 20 years (Statistics Norway, 2012). That same year, on July 22<sup>nd</sup>, 2011, a right-wing Norwegian extremist took 77 young adult lives in twin acts of terrorism. Anders Behring Breivik retaliated against the Labour Party, blaming them for the multicultural developments stemming from the ‘loose’ immigration laws (Ullén, 2012). This was a traumatic landmark event that resulted in a media focus that brought the impact of issues concerning racism and xenophobia to the forefront in Norwegian private and public discourse. The relatively rapid transition to a multicultural society has broad impact.

It is worth noting that specifically in the four hours of the immediate aftermath of the July 22 terrorist attacks, before the identity of Breivik was confirmed and released to the media, there was evidence of a presumption that Islamic extremists carried out the two terrorism acts (Østli, 2012). During these few hours, there emerged a number of reported cases of violent racial discrimination toward minorities residing in Norway as well as Islamophobic rhetoric on Norwegian social networks (Tollersrud, 2011). Although Breivik’s attacks appeared to stem from the increasing Muslim immigration, the prejudiced reactions from some ethnic Norwegians imply the potential existence of a national xenophobic anxiety within the Norwegian public.

Discourse is our primary communication tool. It adapts to a changing environment and reflects the individual’s opinions and attitudes. Classroom discourse related to race and

racialisation has been studied by utilising the methodology of discourse analysis in schools and in educational policy at high school and university levels, especially in the United States (Riggins, 1997; Solorzano, Ceja, & Yosso 2000; Kubota, 2001).

This study was chosen to address the gap in research on racial discourse at a university bachelor level in Norway. Although this thesis discusses the wide subject of the development and implications of racialised discourse, the intention of this study was to specifically analyse racialised discourse as it presents itself in classroom discourse at a university, which is located in a homogenous, traditional and relatively isolated European country under active multicultural transition. There has been limited research conducted at a university level as compared to primary and secondary level education. Research at the university level may appear selective and elitist, in context of a global educational perspective (Fischer & Marcus, 1986). However, public policy and cultural behaviour is often influenced importantly by individuals with higher-level education.

This project uses the technique of discourse analysis to compare and contrast two types of classroom formats as they relate to racial issues in an academic environment. University students would be expected to reflect future attitudes and positions in Norwegian culture and politics. Professors traditionally conduct lecture-based courses with expert knowledge on the subject matter. Students together with a colloquia leader also construct knowledge in interactive-based colloquia. The colloquia leader is not present for the lectures. Therefore, performing the analyses in these two different academic formats permits us to compare the manner in which discourse on race is formulated and plays out in two different settings.

## **1.5 Objectives:**

### Primary objective

- To understand the complex concepts of race and racialisation and further to understand how racialisation is expressed in Norwegian classroom discourse in a university environment.

Secondary objective

- To compare and contrast classroom discourse on race and racialisation in lecture-based teaching and interactive colloquia.

***Research Questions:***

1. How does dialogue related to race and racialisation play out in Norwegian university lecture-based and interactive-based classroom discussions?
2. Can discourse analysis using 'interpretive repertoires' selected from class discussion identify categories of comments that reflect common views and concerns related to Norwegians attitudes towards racial issues?
3. Does classroom discourse on race and racialisation differ in the two different learning settings?

## 2. Literature Review

Ralph De Grillo (2003) proposes that racism in Europe has moved from biological origins to a 'new' cultural racism, known as cultural fundamentalism or essentialism. In the past, European political spheres were concerned with biological essentialism, the idea that physical attributes or genetic make-up determines people's behaviour. However, De Grillo argues that since the 1980s, British and French writers detected a 'new' cultural essentialism, which classifies people based on their cultural backgrounds (De Grillo, 2003). According to Pierre-André Taguieff (1988, p. 14), discourse was "culturalised"...ignoring the explicit vocabulary of "race" and "blood." However, Verena Stolcke disagrees with this point. She argues that 'cultural essentialism' is often misconceived as 'classic racism in disguise', problematically

classifying biological and cultural essentialism as identical approaches to exclusion (Stolcke, 1995, p. 4). However, whether the xenophobic attitudes have a biological or cultural basis, the exclusionary result is similar; a group or groups of people are restricted from full national/cultural membership and participation based on what they are rather than who they are.

Teun A. Van Dijk (1992) argues that without an accepted language to approach race and race related issues such as immigration, a society with a white majority population is at risk of casting a dark voiceless shadow on racialised minorities. Such a 'shadow' would stand in contrast to the image of tolerance and acceptance Norway portrays publically towards ethnicity and immigration.

Professor Jon Rogstad, who investigates social injustices both domestically and abroad, proposes that Norwegians are genuinely invested in racial equality and social equity, but first-hand exposure to contrasting cultures and people is relatively rare. "The racism debate is problematic here. The authorities really look upon themselves and the Norwegian population as being innocent, very proud of being equal and inclusive," (Rogstad, 2013). In contrast to the record of US and other European countries, Norway is not considered to have a history directly connecting to colonialism or slavery. Although history under Danish rule shows that Norway did not import slave labour, Norway was involved in colonial projects such as commercial trading, which transported African slaves to the Caribbean and Latin America. However, 'Danish-Norway' became the first European country to prohibit slave trade in 1803, but continued to carry African slaves to Havana until 1809 (Behrendt & Rawley, 2005). Since this was five years before Norwegian independence from Denmark in 1814, it does not compromise the Norwegian national image of a neutral and morally exemplary nation.

Einar Lie (2002) claims the Norwegian racial context varies considerably from other countries and cultures in that “The Norwegian population is exceptionally homogenous,” (Lie, 2002. p. 802). Until relatively recently, the only registered immigrants in Norway were the Sami people from the far north of Norway, Sweden and also Finland, the origins of the Kven people. However, combined, in the late 19<sup>th</sup> century, the Sami and Kven population in Norway barely comprised of 20,000 people. Yet, the Norwegian authorities began to consider them nonetheless a threat to national security (Lie, 2002).

Bakkerud, A., Moan, A., & Molteberg, K. (2007) explain that since the late 1800s, the Norwegian government has conducted operations at the institutional level that served to detach the national minorities from their cultural heritage by subjugating the minority populations and encouraged an abrupt assimilation into Norwegian society. Mandatory sterilisation was utilised for specifically eliminating the identity of the nomadic Romanian people residing in Norway. The native Sami minority population were coerced to sever any religious ties while also being forced to replace their indigenous names with Norwegian names. It was not until 1989 that the Sami population established a parallel parliament that would overtake responsibility and provided an opportunity for a greater say in issues that concern them (Bakkerud et al., 2007).

It is noteworthy to recall that the Sami and Kven people have the longest ethnic relationship to the physical space of Norway (Marjomaa, 2012). As such, Norway is placed in a relatively unique position in that Norwegians have only confronted ‘otherness’ in what is considered to be their own territory or ‘home-turf’ as opposed to being exposed to alternative cultures through a history of colonisation or territorial expansions.

In 1845, The Sami and Kven population living in Norway were classified together in the Central Bureau of Statistics (CBS). However, the CBS of 1865 added that it was mandatory to count the ‘mixed population’ and to specify which ‘mix’ the individual was comprised of (Lie, 2002). Every subsequent census up until WWII aimed to categorise narrower definitions of non-Norwegian individuals and count them. Theodore Porter (1996, p. 49) suggested, “Public statistics are able to describe social reality partly because they help define it.” Thus, there can be a direct link between public statistics and national/cultural ideology. Supplemental racial categories can often have legal and social repercussions toward the minorities that may carry stigmatised classifications. This was especially true in South Africa during the apartheid when examining ‘black’ and ‘coloured’ classes as well as the indigenous peoples in the US and Canada, (Bowker & Star, 2000).

The Norwegian Central Bureau of Statistics (CBS) used the derogatory term ‘Lapp’ to describe the Sami people and ‘Finn’ to describe the Kvens throughout the “most intense Norwegianization period,” (Lie, 2002. p. 807). Although these terms were considered derogatory, and CBS chief Anton Kiær made note of that in his book Director Kiær from 1882, he still continued to use the stereotypical pejorative terminology throughout the rest of his analyses (Lie, 2002). This makes it appear that there is a conscious prejudice toward non-Norwegian individuals and groups. Furthermore, the CBS classified ‘Finns, Lapps, Returned Norwegian-Americans, dissidents, the blind, deaf and the insane’ in the same category. The purpose was to assess the potential threat this category had toward the status quo in addition to evaluating the challenges they brought and societal examples they set that could have a negative impact on conventional social behaviour.

In 1983, Benedict Anderson pointed out the CBS role as “creating a uniform conception of ‘nation’ for people who lived in isolated districts without direct communication with one another,” (Lie, 2002, p. 812). The CBS contributed to the concept of an ‘imagined community’ revolving around the notion of nation. This affected both the inclusion and exclusion groups influenced by this cultural approach. Such categorisation of a nation’s various peoples emphasises differences based on ethnicity and has the potential to promote discrimination based on physical and cultural characteristics.

Since the early 1990s, Norwegian public debate on immigration and integration has become increasingly polarised. In response, two leading political parties became defined by their view on immigration. The Labour Party (AP) supports a liberal immigration whereas the Progress Party (FRP) supports a restricted immigration policy.

In 2013, the Progress Party joined with the Conservative Party (Høyre) to form a coalition government.

Marianne Gullestad (2006) warns that the risk of an underdeveloped language to discuss race related issues gives rise to the emergence of a ‘colourblind’ societal attitude that intentionally avoids discussions of race related issues as not to appear xenophobic. She argues this is the current approach to race in Norway. Gullestad adds that the Norwegian scholars who defend the neutrality of the word ‘neger’ (negro) are doing so by claiming the public spaces of Norway are ‘white’ with a collective memory of a homogenous national self-image. She argues further that Norwegians do not want to be considered “foreigners in their own country” (Gullestad, 2005, p. 44). Here we see a potentially negative discursive impact on Norway’s ‘new countrymen’ in an attempt to maintain a hierarchal and entitled national self-image.

There are privileges that accompany a sense of national belonging. One of these privileges involves being included in the criteria for what is considered Norwegian. National belongingness emphasises who the “we” of a country are. “We” reveals that this is the stance of the majority of a nation with a sense of opinionated entitlement. However, when there are inclusion criteria, there are also exclusion criteria. Discursive tools have the power to reinforce these rigid national perceptions by perpetuating racial inequalities and cultural insensitivities such as furthering the use of the word ‘neger’ (negro) in 2014.

Today, it is not uncommon to hear or read that Norway’s fundamental values of equality are being threatened by foreign religious and cultural practices, particularly towards women. Anniken Haglund (2002) argues this perspective is grounded in a stereotype that foreign civilisations are inferior to Norway, “Is it possible to construct a new identity on the foundations of the Norwegian ideology of equality?” (Haglund, 2002. p. 402). In Norwegian public discourse, Phelps, J. M., Blakar, R. M., Carlquist, E., Nafstad, H. E., & Rand-Hendriksen, K. (2012) suggest that similarities and differences are rapidly becoming related to the nation-state, with an emphasis on the basis of origins and affiliation of an immigrant group. When concepts such as culture and nation-state are used interchangeably, the development of a national essentialism might be observed branching from cultural essentialism. Phelps et al., propose the transformation from a focus on broad ‘outsiderness’ to a fixation on specific origins can be understood as “implicit representations of visibility markers,” (Phelps et al., 2012, p. 204). This raises the issue of what specifically defines Norwegian nationality. Are ethnic Norwegians the only citizens with unrestricted access to national and cultural ownership? Can non-ethnic Norwegians ever be recognised as fully Norwegian?



Julie Katrine Lindstad and Øystein Fjeldstad (1999) suggest that the word ‘immigrant’ is racially coded in Norway and when mentioned in the media, the common perception is that such an individual represents a liability toward the Norwegian society. They argue that this perspective does not consider the potentially unique challenges and discrimination many immigrants experience daily (Lindstad & Fjeldstad, 1999). Gullestad, on the other hand, highlights how the Norwegian media forums include very few journalists with minority backgrounds, which might partly explain how there are frequently public denials of racist acts, avoiding the issue of racism with an alternative, more palatable explanation (Gullestad, 2005). She further argues that the apparent lack of public compassion toward minorities expressing their feelings of discrimination might be related to a Norwegian reluctance to confront minority injustice on the grounds that it is officially non-existent. However, racism in Norway certainly exists (Døving, 2014). With limited minority representation in the Norwegian media, the immigrant population may feel they cannot express their concerns and consequently may feel as though their opinion is not heard, nor considered important in the socio-political discourse.

How we use specific language reflects our views and reveals where we position ourselves in discussion. Therefore, the available language we have to express ourselves may contribute to the construction of our views and influence our perspectives. Daniel Wodak and Martin Reisigl (1999) suggest racist attitudes and views are shaped and maintained by means of discourse, through which discriminatory and exclusionary practices are prepared, circulated, and validated. In order to understand, and eventually change negative social constructs and destructive racial stereotypes, one must analyse how the words spoken about race and race-related issues reflect and affect the environment.

### 3. Theoretical Framework

#### **3.1 Critical Race Theory**

Critical Race Theory (CRT) is a contemporary academic interdisciplinary field, which emerged within American Legal Theory under the umbrella of the anti-racist movement. CRT surfaced in the 1970s as Civil Rights scholars began to witness the fading momentum of the Civil Rights Movement and became increasingly dissatisfied with the opposition to the desensitisation of race (Phillips 1999, p. 1250; Valdes, McCristal Culp and Harris 2002, pp. 1, 2). CRT employs liberalism, post-structuralism, feminism, Marxism, Critical Legal Theory, post-modernism and pragmatism to critically assess society and culture as it relates to race, law and power (Solorzano & Yosso, 2001).

It has been suggested that one cannot effectively confront racism without addressing sexism, homophobia, economic exploitation and other forms of oppression and injustice. These obstacles are reoccurring echoes of the conservative, post-colonial superstructure of society (Möschel, 2011). CRT asserts that racism emerges as a symptom of a long-existing racial hierarchy within and outside of the racially biased infrastructure of governing law. In this way, CRT focuses less on intentional racism at the individual level, but rather draws attention to the established Europeanised, cultural constructions and structural conditions that create and perpetuate institutional racial discrimination and inequality on a global level. CRT implies that these conservative institutions justify a white supremacist racial hierarchy and may serve to perpetuate persistent xenophobia, racist attitudes and behaviour.

In order to understand how racism is embedded within law on the institutional level, we must first examine how the concept of race evolved from biological origins.

### **3.2 Biological vs. Cultural Essentialism**

Biological essentialism is the belief that people are ‘essentialised’ by their inherited genetic make up or phenotype and their behaviour is determined by their physical traits. The philosophy of biological determinism leads to a discriminatory ‘old racism,’ in which a person is perceived as pre-determined by their genotype and is “gendered, sexed and raced” (Haggis, 2004, p. 53; Gilman, 1985; Ereshefsky, 2010). Through “imperial capitalism and colonialism” the essentialism of non-whites led to the societal and intuitional inequalities of racial hierarchy that persist today (Haggis, 2004, p. 53). The ‘white advantage’ was imperative for the process of cultural assimilation outside of Europe.

The rise of the Third Reich and the apparent subsequent rejection of the Nazi ideology of white supremacy contributed importantly to discrediting the concept of biological racism (Falola & Roberts, 2008). A racialised ranking system was exposed as a human invention, implying an imaginary racial construct (Lewis, 2001). Here a distinction was made between negligible trans-racial biological variations, such as skin-colour and an individual’s intellectual capacity. However, the perception of skin-colour as an insignificant trait serves to de-emphasise the historic and pervasive relationship between race and oppression (Harris, 1993).

Cultural essentialism describes individuals as predetermined by their geo-cultural origins as opposed to their biological phenotype. However, the inescapable chain between geography, culture and self poses as real a threat to individual empowerment as biological essentialism. In this sense, the definition of racism as racial discrimination is rendered obsolete in that race has become ‘culturalised’ and no longer directly biological in origin. Here, a person of colour who criticises a perceived act of racism risks being seen as ‘pulling the race card’ (Lewis,

2001). With the link between race and oppression reconceived and presumably weakened in the eye of the public, there is a misperception that the playing field should be level. People of colour are vulnerable to white criticism for being unable to potentially reach an equal standard of achievement.

Geographically, Norway is relatively isolated, which consequently led to significant cultural and social isolation. However, in recent times, a substantial increase in multicultural immigration occurred. In 2013, The Confederation of Norwegian Enterprise [Næringslivets Hovedorganisasjon] stated “we are pushing the limit for what we can sustain on immigration,” (Ueland, 2013). Although the Norwegian welfare system is well developed, resources are limited. Norwegians may perceive these anticipated additional responsibilities related to the extent of immigration, as a threat to their social welfare (Brochmann, 2008). This perception may expose these disadvantaged migrants as potential targets for social exclusion through the hierarchal lens of cultural essentialism. Norwegians may perceive themselves as victims. Immigrants may be perceived as representing a potential burden to social services, supported by Norwegian public taxation.

### **3.3 Colourblindness**

Perceiving race as a creation rather than a discovery led to an altruistic ‘colourblind’ attitude rejecting racial consciousness and intentionally avoiding race recognition. Although treating people equally and perceiving people as essentially alike might appear to be compatible, they have conflicting implications. Treating people equally assumes behaviour with mutual respect. However, perceiving people as the same de-emphasises race and thereby denies or ignores racism. The historical and current impact of institutionalised racialised inequality is lost (Möschel, 2011). This has led to scepticism among CRT scholars regarding colour-blindness as an anti-racist approach.

Norway's historically racial homogeneity has led to racial stereotypes often replacing personal experience. This setting leads to a nation where the people "often have little contact with people of colour in their everyday lives and are, therefore, much more dependent upon cultural stereotypes and assumptions when trying to imagine the situations of others in...society," (Wills, 1996, p. 385). Thus, only blatant individual acts of racism get attention while the more structural, institutionalised forms are not obviously apparent or recognised. In this sense, a colourblind approach may serve to perpetuate the negative impact of systemic racist indoctrinations.

Colourblindness may serve to foster white supremacy in that the approach ignores racial considerations and fails to recognise institutional racism. An example of the risk of a colourblind approach may be found in biased punishment of rapists within the United States. The longest prison sentences are allocated to black men who rape white women and the shortest for white men who rape black women (Crenshaw, 1991). This is a clear example of institutionalised racism. A racial hierarchy among the victims and perpetrators is maintained. The punishments demonstrate the concept of a perceived white victimisation due to the scarcity of intersectionality, which in the context of anti-racist law means recognising individuals hold more than one identity, such as gender and race; being a woman and being black. Both identities have a history of oppression, but combined these two demographics can act synergistically to create a substantial obstacle to individual empowerment and societal well-being that may go unrecognised in a colourblind society (Crenshaw, 1991).

A typical example of cultural stereotyping is presented in a recent Norwegian article by Maria Lillebo (2008) titled Norske jenter har seg selv å takke [Norwegian girls have themselves to

thank] based on a radio interview Abid Raja on Norway's largest commercial radio channel (P4). The article involved three men from Somalia and Senegal addressing the provocative clothing choices of young Norwegian women and appeared to select the most inflammatory and misogynistic comments from the three men toward Norwegian women and culture. The second half of the article consisted of the responses based on the majority of comments from the ethnic Norwegian readers, who appeared to have expected this stereotypic 'predatory' attitude toward white women. It seems as if this article, and similar ones, enables a rationale for implicit and explicit racist perspectives. There is little doubt that ethnic Norwegians 'see race', especially given that the head of Oslo's 'violence and morality' police section, Hanne Kristin Rohde is quoted as saying, "Vi ser at flere av dem har et kvinnesyn som tilsier at de når som helst kan ta kontroll over andre personer, da helst kvinner," [We see that many of them have an attitude and behaviour towards women that permits them to take control over other people, preferably women, at any time,] (Molstad, 2011).

Socially constructed racial hierarchies are still tightly linked to socioeconomic and institutional inequalities. The 'colourblind approach' may obstruct the process of approaching racial equality by declaring race as a construction and thus, not a substantial threat to well-being. Not recognising the current institutionalised systems, which are a direct result of a colonialist past, serves to underestimate the reality of the racial privilege of 'whiteness' that endures today (Anghi, 1996).

An increasing number of white people believe that they live independently of racial constructions and that race is not an issue of their concern, which demonstrates the perils of adopting a colourblind approach to race and racism (Forman, 2001). In this way, cultural essentialism does reproduce a racial hierarchy, wherein white supremacy is still protected

under the ideology of the Western ‘civilised man’ compared to the non-Western ‘savage,’ (Mahmud, 1997).

### **3.4 Civilised vs. Savage**

Failure to recognise that racism may be a salient element in violent acts, protects the perpetrators by avoiding recognition of potentially racially motivated violence. A hierarchy of the ‘civilised vs. savage’ develops. An Italian storeowner and his son beat an Italian teenager of colour to death, whilst using racial slurs in the process. Both the father and son were charged with murder, but the public prosecutor did not consider the racist element relevant to the act (Möschel, 2011). This example of not detecting the racial factor in crime can skew the national statistics on race-related crime and underestimate its prevalence (Razack, 2004).

The process of ‘essentialising’ an identity to a geographic location perpetuates a Eurocentric and colonialist global mentality by perceiving those other than non-European whites as uncivilised ‘savages’. This is exemplified in the Spanish confrontation with the Native Americans in the early 15<sup>th</sup> century (Anghi, 1996). The Natives had to adhere to the regulations laid down by the Spaniards. Any failure to do so would be considered as an “act of war” that justified violent retaliation (Anghi, 1996 p. 326). Spaniards extended their active self-serving European law to the New World as a tool for applying sovereign power over the Atlantic, maintaining their position as the civilised representatives (Anghi, 1996). Centuries later in the United States, Jim Crow’s laws of ‘separate but equal’ were established to convey that the societal separation of ‘coloureds’ from white Americans was the public process of achieving racial equality by legislation (Harris, 1993). The dominant race in power formulated these laws, which provided legal framework that placed non-whites at a disadvantage and their limited success as their own responsibility. White privilege recycles

inequity through unequal legislation and access to social services between whites and people of colour, perpetuating inequality through racial bias.

In Norway, there is a progressive polarisation between the ethnic Norwegian ‘host’ and the immigrant ‘guest’ (Razack, 2004). The ‘guest’ in this scenario may be perceived as a potential cultural threat. This is especially apparent with regards to Norwegian-immigrated Muslims during the last several decades. Razack suggests that the divisive nature of this relationship may be linked to predominantly negative media attention toward secular ‘parallel lives’ of Muslims in European civilization where women are perceived as victims of Muslim patriarchy and oppression (Razack, 2004). Young Muslims who are raised in witness to the sense of European superiority are polarised from the greater community and do not develop alongside modernist and ‘civilised’ ideals. Although less explicit than in France or England, Razack insists Norway still operates under an anti-Muslim attitude by “culturalising” violence as inherent in Muslim people and culture (Razack, 2004, p. 131).

Hege Storhaug (2003), the author of *Human Visas: A Report from the Front Lines of Europe’s Integration Crisis*, compared British Muslims and Sikhs on their level of individual, social and economic success with the extent of their integration. The case highlighted that Sikhs were collectively more integrated into Western culture with a higher individual rate of success while British Muslims were observed as isolating themselves in predominantly Muslim communities with limited exposure to a ‘Western’ experience. The case put forward in *Human Visas* is there is a strong correlation between Western integration and overall Western success. Further Storhaug argues that avoidance of Western assimilation leads to perpetuation of gender discrimination, including the “Larger the family, the more imprisoning it is” for Muslim women (Razack, 2004, p. 137). However, Razack disagrees and describes the hypocrisy in the Norwegian critique of arranged Muslim marriages. Norwegians too have an



overwhelming tendency to marry within their own cultural and racial background. Since *Human Visas* is concerned with the Western perspective on non-Western groups expanding into European territories, Razack critiques that Storhaug does not adequately admit that most groups tend to marry within their own race and ethnicity. Razack emphasises that many different groups of people preserve their cultural identity within their own ethnicity or race.

In the context of the 'War on Terror', the West's specific concern over the perceived threat of Muslim immigrants may be related to a growing perception of synonymy between Islam and extremism (Volpp, 2001). For example, after an evaluation of when the word "Islam" appears in French high school textbooks, it demonstrates that "Islam" frequently emerges alongside words such as "terrorism", "war", "September 11<sup>th</sup>" and "Al Qaeda," (B. Mabilon & F Durpaire, 2014). This example of institutional indoctrination is divisive and indicates a civilised vs. savage perspective.

### **3.5 White privilege**

Favoured members of a population possess social advantages in that socio-cultural traditions and the economic structure legitimise and maintain their influential and empowered position. Specific privileges securing advantages for the white population are described as white privilege (McIntosh, 1988). Ethnic Norwegians are privileged through the concept of 'host vs. guest', which engenders a strong ethnicity and identity. Additionally, by virtue of their isolation, the majority of the Norwegian population remains primarily white. However, the size of the majority in a population does not necessarily reflect the extent of political power. Afrikaners in South Africa possessed the authoritative power, but were a numerical minority. This suggests that race may sometimes be a more powerful factor than being a member of the majority.

Progressively fading awareness amongst white populations of the connection between class, status and race may serve to mask the concept of white privilege. White privilege expands opportunity in addition to providing greater perpetuation of economic, political and social security. These advantages desensitise the privileged group and reinforce the status quo (Harris, 1993). When the existence of a white privilege is denied or disguised, non-whites are further disadvantaged because the obstacles directly related to race are not recognised as hindrances to realising their full potential. Failing to identify these obstacles inhibits the development of effective measures to address them.

One example of white privilege is displayed through the phenomena known as ‘white flight’. White families living with small children in the city are very likely to move out of the city and into the suburbs. Although white families will make this move for various reasons, race is still directly correlated to housing location and school selection. On why she moved from a diverse urban neighbourhood to the suburbs, a white teacher responded: “It was either live in Townside and send them [children] to private school, but then I’m thinkin’ well I probably wouldn’t let ‘em hang out with the kids in Townside. So, do we move out and send ‘em to *public* school and then at least he has a community,” (Lewis, 2001, p. 797). The teacher’s priorities target a homogenous suburban neighbourhood. Their children will attend public school with possibly lower educational opportunities than a private school but in her eyes, with stronger community ties. The property of whiteness is being protected by conveniently escaping the aesthetically displeasing urban realities of inequality and executed by recognizing the value of the racially select neighbourhood. The opportunity to move to the suburbs is not inherently restricted to white families, but the movement itself represents a tangible recognition of greater community opportunities as well as a display of a protective nature against non-whites (Lewis, 2001). The evolution to the embedded system of white

supremacy was based on colour, race, status and property. “Whiteness was the characteristic, the attribute and the property of free human beings,” (Harris, 1993, p. 1721). White was a “consolation prize,” (Harris, 1993, p. 1758); the poor white lower-middle class worker maintained certain privileges and was still able to attend social functions and access public spaces such as parks.

### **3.6 Likhet (Imagined Sameness)**

Norway has historically been a relatively homogenous society with a culture-specific identity currently undergoing a multicultural transition. Gullestad (2002) argues that the values that contribute to the development of the Norwegian identity include ‘Janteloven’ (the law of Jante) a set of rules placing an emphasis on the importance of individual humility and ‘likhet’ or ‘imagined sameness’. Janteloven was proposed by Danish author Aksel Sandemose in 1933 and refers to ten collectivistic laws to communal welfare. These laws serve to consider individual achievement as unsettling due to the stability of societal structure in Scandinavian communities. These central value concepts encourage the celebration of commonalities and similar social perspectives, whilst discouraging deviations and differences from the status quo. These culture-specific principles function to construct a well-defined, collectivistic and inclusive identity for those who fulfil the conventional image of a ‘Norwegian’. However, Gullestad suggests that the process of empowering cultural identity through a sense of national cohesion has set the stage for potential exclusive and xenophobic repercussions preventing the successful integration of immigrants (Bygnes, 2012).

The transformation from a homogenous to a heterogeneous population might face obstacles in the form of fundamental cultural values that discourage the community from having associations with people who are ‘different’ representing classic xenophobia. Gullestad theorised that ‘imagined sameness’ was originally constructed with the purpose of promoting

standard behaviour in society. In a budding multicultural society such as Norway, these ‘unifying’ cultural values place racialised and immigrant non-ethnic Norwegians at risk of being excluded from these cultural values. Ultimately, the excluded group are at risk of being unable to achieve the ‘privileges’ and cultural benefits of ownership of their Norwegian nationality (Gullestad, 2002). In this context, the concept of the ‘celebration of commonality and similar social perspectives’ may marginalise instead of unify. This in turn impedes the process of individual empowerment.

### **3.7 Interest Convergence**

CRT defines the term ‘Interest Convergence’ as the privileged population within a community supporting social change and equality while simultaneously being unwilling to sever their hierarchical relationship with the social constructions of race that shift conveniently to conform with the perspectives and priorities of the ruling class (Delgado & Stefancic, 2012). The idea that the privileged group will support social change that favours an oppressed group only to the point where it also benefits the privileged, may be the description of a conservative process leading to restrictive policy-making without the incentive for potential gains for the ruling class. For example, in 1954 in the state of Kansas, *Brown vs. Board of Education* reversed the 1896 *Plessy vs. Ferguson* case of ‘separate but equal’ by deeming racial segregation within and outside of school systems as unconstitutional and “inherently unequal,” (Harris, 1993, p. 1750; Brophy, 2008). However, the decision to overturn the ‘separate but equal’ framework, which was rooted in the legal infrastructure of the United States, occurred at a convenient time. The Cold War was developing and the United States was emerging as a global authority with moral responsibility. Although the Civil Rights Movement was well underway and was increasingly successful, the official abolition of ‘separate but equal’ was received with international respect and the U.S. was perceived as a

progressive, ethically principled nation, which simultaneously strengthened their hegemonic position in the international political arena.

This ideological concept will be a useful lens for analysis given the privileged position of ethnic Norwegians while also considering their peaceful international reputation.

## 4. Data and Methods

### **4.1 Protocol**

This study investigated one Norwegian bachelor-level university course in two traditional lectures (expert knowledge) and two colloquia (constructed knowledge). Verbal discourse is evaluated as it relates to identity, nationalism, race, belongingness, inclusion, difference, exclusion and ethnicity. The course offered at the University of Bergen took place in a traditionally structured classroom that registered 43 students but rarely exceeded 12 students per class.

In order to have effectively investigated how identity was discussed in a classroom setting, a course under the institute for archaeology, history, culture and religious science was targeted for including topics tied intimately close to race, ethnicity and cultural encounters. This course explored the cause and consequence of war, with a specific focus on the impact of forced migration. The multifaceted and diverse course content encouraged forthright and opinionated representation. The researcher attended all course sessions for the first month. Depending on the available data on racial discourse, subsequent course sessions were selected for transcription based on topic.

Eight hours of lectures and colloquia were coded, transcribed and analysed in Norwegian before being discussed in English with a focus on discursive patterns related to identity.

One can assume that the average Norwegian is relatively fluent in English. However, nuances based on dialogues in the native tongue might not be readily expressed in a second language. Therefore, one should not assume that the average Norwegian is well rehearsed in English racial discourse. Thus, the language barriers students might confront could prevent the true message from being expressed; given political debates take place in Norwegian. In order for the discursive research to adequately represent Norwegians' various opinions and stances on race and racialisation, the Norwegian-spoken course was chosen where the majority of the class is comprised of ethnic Norwegians.

As a bilingual Norwegian/American citizen, the researcher is aware that American-English has few dialects, but an abundance of accents. In contrast, the richness of the Norwegian language and the sensitivity to small nuances in discourse is related to the plethora of regional dialects. Therefore, one criterion for course selection for this project is that Norwegian was the language of instruction and discussion. Efforts to distinguish between dialects were made so the data collection would be sensitive and specific enough to detect these nuances and analyse the breadth of Norwegian expression.

## **4.2 Data Collection**

### ***Audio-Recording Devices***

Data was collected through the use of an audio-recording device. The audio-recordings were analysed and interpreted in Norwegian. After the transcriptions and analyses were completed, the findings and relevant excerpts from the transcriptions were translated into English. The 'Zoom H4N' was an appropriate audio-recording choice for classroom settings because it was designed to clear up clutter and pinpoint dialogue in loud spaces. In addition, the Zoom H4N offered the unique capability of adjusting the angle of the microphones from a narrow 90° for specific individual recordings to a wide-range 120° for a larger spectrum of audio data

recording in a classroom setting. There were a minimum of two and a maximum of four H4N devices strategically placed for recording at each lecture and colloquium, dependent on the size of their respective participant sample.

### 4.3 Collecting information

The researcher categorised the participants of the study (professors, students or colloquia leader) based on their participation in class (low/med/high) and the racial signifiers ‘white’ or ‘person of colour’ (POC). See table 1.

The researcher made a personal note providing an alias for each of the participants to aid in recollection during the transcription and observation process.

Table 1.

DEKKNAVN [Participant Alias]	HVOR MYE SNAKKER [Level of Talk] (low/med/high)	AKTUELLE OPPLYSNINGER [Relevant Information]
Professor A	High	Male, (POC)
Professor B	High	Male, (white)
Colloquia Leader: Tone	High	Female (white)
Helen	High	(white)
Christine	Med	(white)
Klaus	Med	(white)
Heidi	Med	(white)
Ruthie	Med	(white)
Kari	Low	(POC)
Janine	Low	(white)
Brit	Low	(POC)

The key to transcription symbols is on page 98, Appendix A.

#### **4.4 Observations and Reflections**

The observer recorded observation notes, reflections, and general comments throughout the duration of the course. These were appropriately entered into the transcripts as well as typed on a separate document with a ‘setting diagram’ of the classrooms to aid the researcher in subsequent analysis and help the reader visualise the context (See Fig 1 for an example).

Fig 1.1 is an example of one of the layouts of the UIB lecture classroom. Details of each classroom layout are provided in appendix I.



Fig 1.1

Lecture 30/08/13

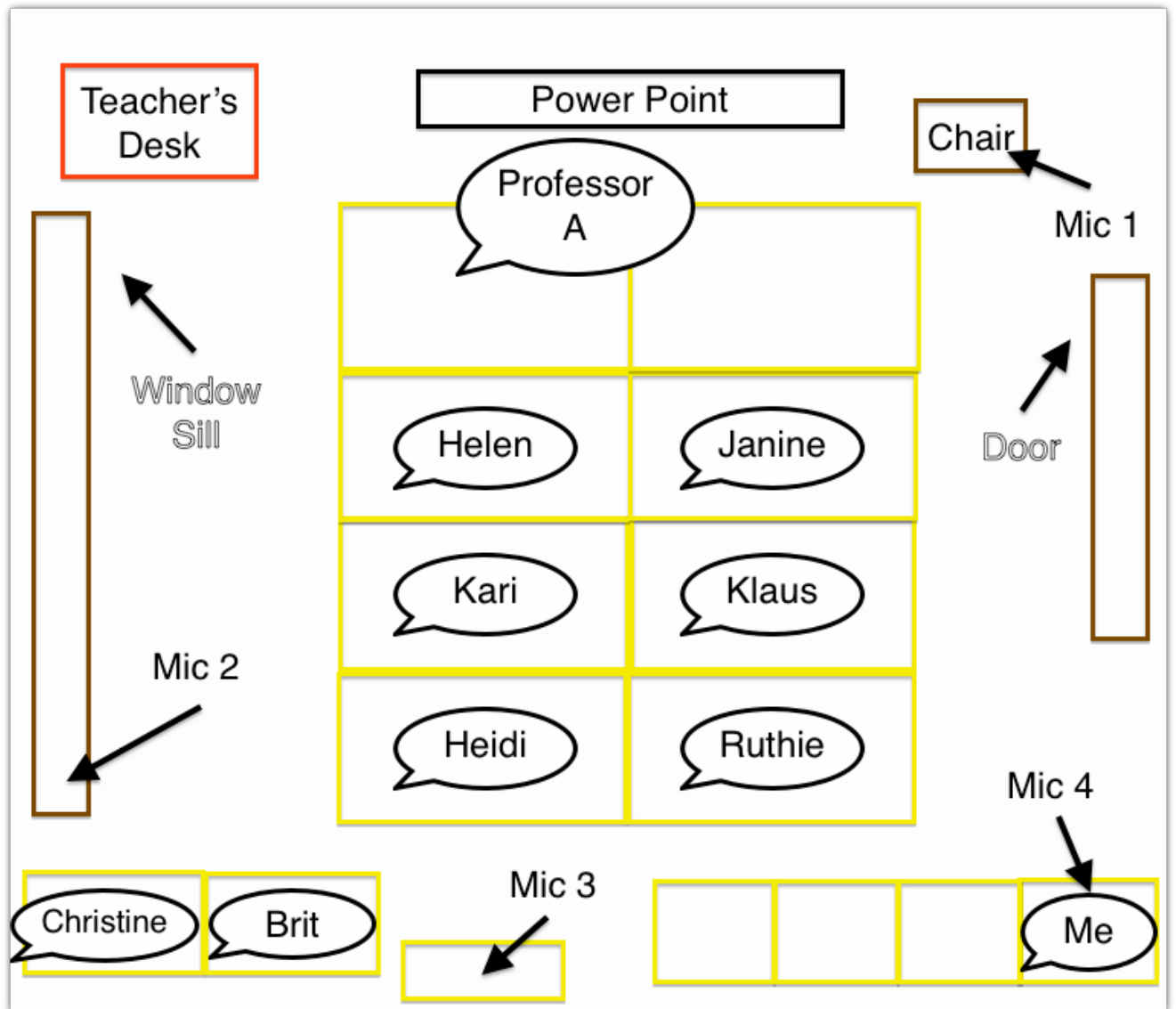

## **4.5 Discourse Analysis**

Discourse analysis is the critical examination of both spoken and written communication. This analytic approach is a guide to assist in the interpretation and analysis of the impact of specific language. In this study, only issues related to how race was talked about - or talked around (ie. addressed or avoided) were observed. Although discourse analysis may help interpret the intent of the speaker, there was no attempt during the transcription or analytical process to interpret the intentions behind the spoken words. This project focuses on the effect of the words themselves. This discourse analytical technique is termed discursive psychology.

## **4.6 Discursive psychology**

Discursive psychology suggests people frame their identities through the subjective construction of their social reality. This approaches psychological material from an interactional perspective, exploring how psychological categories are managed and used through the selection and formulation of dialogue. Discursive psychology differs from traditional psychology by viewing language as a resource that provides the possibility for the examination of the ways people talk about or construct their personal attitudes, memories and emotions (Wetherell & Potter, 1987). There is a distinction made between how people talk about the world and why people talk about the world, in that discursive psychology methodology does not address the study of interior processes such as intentions, feelings or motives - not why words were chosen, but how those words reflect the individual or collective social perception. Discursive psychology challenges the claim that people have pre-determined attitudes or social stances by rejecting the idea that social reality is an objective discovery, instead of viewing it as a cultural construction. One's individual perception of their social reality may reveal how they perceive their world, community and selves.

## **4.7 Discursive Psychology and Race**

Discursive psychology takes a critical approach both to the individual and social impact of prejudice and racism. Instead of intrinsic xenophobic responses being responsible for exclusionary behaviours, discursive psychology explores the dominant institutional and discursive practices that are established in society. Categorisation and stereotyping are not considered cognitive processes but culturally adaptable, context-dependent discursive processes that are strategically employed to achieve social actions such as “blaming, accusing and justifying,” (Le Couteur & Augoustinos, 2001, p. 217). Discursive psychology proposes that racism is collaborative and communicative, perpetuating a seemingly legitimised hierarchal perception of race on a society’s collective social reality (Le Couteur & Augoustinos, 2001). This in turn emphasises that exclusionary practices based on a self-congratulatory attitudes toward one’s own race are enabled through cultural factors.

## **4.8 Unit of Analysis**

- The analytical method focused on what people said and how they said it:
  - What observable actions were displayed related to race?
- What cultural resources were used by speakers and how?
  - What was the effect and how were individuals and their social reality being represented through speech or text?

Two specific discourse analysis tools were utilised to interpret the translated data. These tools were taken from traditional discursive psychological research terminology:

### ***1. Interpretive Repertoires***

Interpretive repertoires describe how we relate ourselves to objects and events in our personal and collective social realities and are the foundation of conversation (Edley, 2001). In this

way, “linguistic resources...can be drawn upon and utilized in the course of everyday social interaction,” (Wetherell, Taylor & Yates, 2001 p. 198). A salient point here is although people construct their own social realities, the information by which they develop their ‘worldview’ is frequently reinforcements of persistent and pervasive historical narratives. Jonathan Potter’s metaphor that a society’s collective reality is a library of books we can borrow, describes the concept that our future social realities are primarily influenced by previous social realities (AIMCA, 2010). The interpretive repertoires that emerge from the racial discourse will be examined and discussed.

## ***2. Ideological Dilemmas***

Ideological dilemmas occur when someone draws from two or more conflicting interpretive repertoires to discuss a topic. Ideological dilemmas arise due to the inconsistent nature of common sense thinking, constructed from hypocritical ‘lived ideologies’ (Billig et, al. 1988). The concept of ideological dilemmas emerged to describe confrontation of the conventional Marxist notion that ideologies were a cohesive and consistent sets of ideas that promoted and reaffirmed the position of elite members in a society. Billig split the term ‘ideology’ into the Marxist ‘intellectual ideology’ and ‘lived ideology’ (Billig et, al. 1988). Lived ideologues were comprised of “beliefs, values and practices of a given society or culture,” (Wetherell, Taylor & Yates, 2001, p. 203). In this way, lived ideology and ‘culture’ appear to be interchangeable terms.

One principle difference between ‘intellectual’ ideology and ‘lived’ ideology is that ‘lived’ ideology is not cohesive or consistent, but contradictory and shifting. In reality, there is rarely consensus concerning a common sense view, with people in disunity over how to act in varying social circumstances. Ideological dilemmas should provide us the framework for

observing the “structuring effects of competing or contrary themes in all but the most platitudinous conversation exchanges,” (Wetherell, Taylor & Yates, 2001, p. 204). The suggestion is that the rigidity between ideological themes becomes a catalyst for conversation. Ideological dilemmas may highlight and define the inconsistencies within race and racialised discourse. These socially constructed contradictions within an individual’s character may potentially be developed into prospective measures for agency and transformation; generating an opportunity where novel views can surface.

#### **4.9 Course Selection**

Course selection was important in that data collection is dependent on racial discourse being present. Norwegians traditionally prefer not to discuss their opinions on race and immigration and avoid the available loaded racial terminologies. No one wants to be perceived as a racist. Therefore, the emergence of Norwegian nuances and symbolisms in verbal expression without the means of explicit racist or xenophobic linguistics has been observed (Gullestad, 2002). It is important to identify the various connotations used in discourse in order for speakers to understand the impact of their words. We can analyse these interpretive repertoires to understand how the speakers position themselves in relation to others in a group ie. Who are ‘we’? And who are ‘they’? This could reveal what kinds of repertoires exist in the Norwegian discursive space to discuss racial issues. Some types of discourse may lead to more productive and generative discussions about race and racialisation, demonstrating that such repertoires do indeed exist in the Norwegian discursive space.

Due to the concepts related to “likhet” (imagined sameness), ethnic Norwegians may appear to be socially introverted to avoid being perceived as different. The course selection, therefore, took into account disciplines that forced students to speak out about opinions and voice their views openly. The disciplines of history, culture and religion are appropriate

examples as students are encouraged to subjectively formulate their opinions as well as set the stage for inquisitive investigation into the past.

The courses with topics relevant to this study are primarily lecture-based (expert knowledge). However, many of the courses require weekly group seminars/colloquia for the purpose of negotiating strategies to tackle objectives and assignments. The disadvantage is that there are few courses solely dedicated to group-work (constructed knowledge). However, the course under investigation allowed the opportunity for both 'expert' and 'constructed' educational approaches.

Attaining access to observe the selected course included contacting the responsible professor. The objectives of the study on how race and racialisation play out in Norwegian university classroom discourse were explained. The professor was assured that this process of data collection would have minimal effect on the conduct of the course (See page 105, Appendix D). One H4N recording device was stationed near the professor and at least one more strategically positioned to record the class. At the beginning of the lectures, the participants were told that the researcher was responsible for part of a larger project that was approved by NSD (Norsk samfunnsvitenskapelig datatjeneste). The researcher's objectives within the larger study focused on studying 'difference,' with an emphasis on identity, nationality, inclusion and exclusion.

#### **4.10 Validity, Reliability and Generalizability of the Findings**

Validation of the methodology in discourse analysis is challenging in that conventional, validated procedures for collecting and assessing the knowledge are currently unavailable. Qualitative research-based assumptions or findings cannot with certainty be applied to the 'real-world'. Attempts to replicate the findings to verify their validity may lead to divergent

results due to the subjectivity of the observer. This limits the ability to generalise the findings and may limit the applicability of the results. Reliability and validity are not easily assessed in discursive work. Potter suggests the four important validation tools are deviant case analysis, participants' understanding, coherence and reader evaluation (Potter, 1996). Only the latter two will be incorporated into this study.

*Coherence* refers to the tendency discourse analysis has for building on previous discursive studies. The term 'coherence' describes the responsibility of each researcher to assess the validity and relevance of previous works that are incorporated into their projects (Edwards & Potter, 1993). Without a sense of consistency in the progression of discursive works, researchers cannot visualise the transformation of language over time and culture.

*Reader Evaluation* has the potential of being the most important and distinctive feature in the validation of discourse work. Here, the reader's judgments decide whether the researcher presents rich and comprehensive resources in a way that allows an evaluation of researcher competence (Potter, 1996). Unlike quantitative research methods, qualitative research results are dependent on the researcher's tenacious integrity. It is tempting to discredit a researcher's discursive research because only one observer is present for the data collection. Therefore, the reader's evaluation forms the basis for assuring validity to a discursive study.

More specifically, in discourse analyses, no one but the original researcher should properly interpret the data. The events are situation-specific and the use of language is spontaneous and dependent on the classroom's immediate focus in the topic under discussion. An outsider's interpretation of discourse analysis has been termed "methodological anarchy" (Seale & Silverman, 1997: 380). Thus, the data collection, integrity and interpretation of the findings

rely primarily with the researcher and his aptitude for producing reliable data. This paramount responsibility serves to limit the reproducibility of the study.

Generalising the findings in discourse analysis is challenging. In a study of race and racialisation in Norwegian university classroom settings, the Norwegian language itself is being analysed. Language in this case will be considered as an imperfect, potentially underdeveloped and flexible system. This implies languages are adaptable and have not necessarily evolved at a pace that can effectively address more recent cultural phenomena. The aim is to widen the lens on the features that arose during data collection as seen through a societal and national scope. A strength of this method is the researcher can attempt to generalise the findings to identify and categorise linguistic features that emerged during data collection that are prevalent in varying social circumstances that relate to the discursive theme of race and immigration (Taylor, et al., 2001). What is the common public stance on race and immigration in Norway? What words or expressions are employed when discussing topics related to racial issues and by whom are they spoken? Although the applicability of the results should be restricted to the specific situation assessed, the findings should suggest future fruitful directions leading to greater generalizability. The nature of data collection in discourse analysis requires a flexible and adaptive research design.

#### **4.11 Role of Researcher**

As a first generation Norwegian, there are two clear aspects of my background that have sensitised me to race related issues. The first is my mother's white South African upbringing. She was raised in Durban during the apartheid and moved to Norway in her twenties. She raised her children to be aware of the consequences of social injustice and the perils of racial inequality with an encouragement for open discourse. The second aspect relates to the fact my father is an American Jew raised in multiracial Philadelphia living most of his life in Norway.



This multicultural background sensitised me to race related issues. I have always been concerned with racial inequality and stand opposed to language that may be interpreted as perpetuating the racial divide.

My exposure to American culture during my four years of college in Worcester, a multiracial, working-class city in Massachusetts further intensified my intolerance to racial slurs and bigotry. There is a long and pervasive history of racial conflict in the United States that has led to a focus on racial consciousness. The development of a racial awareness during college cultivated a curiosity within me to examine the historical factors that contributed to the installation of racial hierarchy. Due to my multicultural origins, I developed a strong perspective on the matters related to immigration and racialisation. Self-awareness and academic reflexivity are elemental cornerstones for valid qualitative research methods, especially when there is an understanding the material might have subtle personalised attachments to the researcher. Therefore, I kept an ethnographic journal for my own reflexivity. This maintains confirmation that my findings are consistent with what the Bergen public is saying or not saying about race and ethnicity, so as not to allow my views to influence my findings.

Discourse analysis employs a subjective methodology and the role of the researcher in both data collection and interpretation is central. Discourse analytics are interested in discovering patterns in language and verbal discourse. In addition, there is potentially valuable information in the patterns of language activity and occurrence. Once a pattern is observed, the researcher will then make an epistemological claim about it (Taylor, et al., 2001). How does a researcher come to an assertion about their observations?

On one end of the analytic spectrum stands positivism and post-positivism. These principles lie at the core of our contemporary perception of physical science. Positivism and post-positivism have varying assumptions but both essentially involve using well-established and appropriate methods for extracting knowledge that can then be applied to the ‘real-world’ (Taylor, et al., 2001). Researchers claim an observed pattern and the relationships within are universally applicable arguing positivistic research approaches can be successfully replicated. This may be true in well-recognised and controlled observational settings such as scientific laboratories but not in an unpredictable venue such as a university classroom.

The opposite end of the spectrum relates to a social approach comprised of critical theory, postmodernism and post-culturalism. This tradition expresses a necessity for the researcher to interpret the data with appropriate conservatism. Here, the researcher does not claim to have unravelled a universal truth, but instead offers an interpretation of a specific observed instance with an emphasis on the researchers inescapable prejudices (Taylor, et al., 2001). My project explores a restricted and fairly isolated observational setting. Therefore, my data was collected with an understanding that these data might not reflect the Norwegian society as a whole. The collected data guided my interpretation and contributed to speculation concerning future strategies of investigation. The research design must adapt to the nature of the collected data.

Researchers have a strong influence on the outcome of their discourse analyses. Without the salient conscious understanding of their position in their research, the ramifications can significantly skew the interpretations. Due to the numerous variables involved in social-world research, few assumptions or predictions can be made in confidence, (Taylor, et al., 2001). Therefore, the researcher’s aim is to analyse the meaning and significance of an event, instead

of attempting to control and predict it. Furthermore, no claims of an objective, single truth are possible due to the nature of discourse analysis. When research involves examining people, there are multiple viewpoints to consider. These viewpoints remind us of the impossibility of pure truths in social-world research. Researchers cannot avoid the inevitable observer/researcher partiality they have towards their studies and thus, should strive to deliver their findings with objectivity.

The role of the researcher is reduced to an observer by removing the opportunity for participation in the study (Taylor, et al., 2001). Audio-recording makes the data collection process one-sided and non-reciprocating. Since the type of discourse which represents relevant data is known, avoiding the subconscious urge to manipulate subject matter is challenging (ie. interviews for the benefit of the study). Awareness of the potential problems created by active participation from an observer is important and attempted to minimise the effects of the data collection on the situation under observation. One might assume that microphones are reactive measurement devices. However, a recent study titled “Camera-Related Behaviours during Video Recorded Medical Interactions” suggests that people quickly return to their natural mannerisms after the initial awareness of being recorded (Albrecht, et al., 2007). It is reasonable to assume that human reactions to audio recordings would be similar to video recordings.

#### **4.12 Ethical Considerations**

Audio-recording in a classroom is considered by the Norwegian Social Sciences Data Authority, NSD (Norsk samfunnsvitenskapelig datatjeneste) to be the same as audio-recording in a public space as long as the individual student’s anonymity is preserved and identifying information is not collected. However, because the professors of the course might be easily identifiable, the principal investigator for the larger project applied and received

approval from NSD. The interpreted data will be translated to English. Thus, any direct quotes in Norwegian will be presented in both Norwegian and English. It is likely student's first names will be used during the observed and recorded courses. Therefore, names and any other identifying information will not be transcribed. This study is a part of a larger EU-funded project exploring race and racialisation in higher education in Norway. These data will be a part of the larger project and thus audio recordings will be destroyed after the project has concluded in 2017.

The data collection process did not commence until the participants were informed of the nature of the study. In my introduction at the first recording session of the course, I explained I was interested in studying power relations and issues that connect to difference and diversity as they surface in classrooms at the University of Bergen. The introductory statement will not specifically name race and racialisation for two reasons: i) Not to put course participants on the defensive (due to the way 'race' is understood in Norwegian society, as discussed above), and ii) Because there is a good chance that other dimensions of difference will be analysed as part of the larger project of which this study is a component.

## 5. Findings

Two key categories of interpretive repertoires were frequently identified during data analysis that represented common themes: 'Whiteness' and Norwegian Ethnicity.

A smaller but significant third category of interpretive repertoires was observed: The Racialised 'Other'.

For each of the three categories, excerpts of classroom discourse that illuminate how the interpretive repertoires play out in the lectures and colloquia will be presented and analysed.

## 5.1 'Whiteness'

'Whiteness' encompasses numerous specific examples which participants appear to draw from when addressing issues related to race, ethnicity, nationality, inclusion, exclusion, belonging and identity. The category of 'Whiteness' includes interpretive repertoires established within Norwegian discourse, which describes an essential trait of a 'true' ethnic Norwegian.

### *Whiteness interpretive repertoires:*

Examples that were identified during data analysis are:

Whiteness is pure - Norway is a white space - White Europeans are civilised -

National/cultural membership is extended to select 'honorary whites' - White people feel entitled to privilege and authority - White Europeans are colonialists

### *Whiteness is 'pure' (1 excerpt)*

This interpretive repertoire suggests a celebration of cohesive racial homogeneity. Specifically, an exclusive and pure national and cultural identity is implied.

#### Colloquia

1 Helen: Vinter idrett spesielt- Lillehammer OL da det var det- som- var ikke den-  
2 multi-etniske norsk- Norge: da: var Norge da den rene naturen det var kalte det-  
3 ikke små troller@ men ###01:32:26 et land  
4 med norske myter og super norsk. Men så vi vil ikke bli- ikke bli kalt  
5 nasjonalister- vil bli sett som negativt - i andre land  
6 Tone: [Mhbm]  
7 Ruthie:[Mhbm]

Translation:

1 Helen: Winter sports, especially Lillehammer Olympics - that was when- there  
2 wasn't that multi-ethnic Norwegian- Norway: when Norway was the pure nature  
3 and it was called- not small trolls@ but ###01:32:26 a land with Norwegian  
4 mythology and super Norwegianess. But we don't want to be- don't want to be  
5 called nationalists- because it is seen as negative- in other countries.  
7 Tone: [Mhbm]  
8 Ruthie: [Mhbm]

27/09/13

Time: 01:32:09

Winter Olympics is a special time in Norway, especially for Norwegians. A country of less than five million dominates the international athletic winter-sport competitions bringing gold, pride and satisfaction to its citizens. Helen is describing a different era in Norwegian history, when the Norwegian population was mainly considered a homogenous ethnic group, recalling a time when Norwegian society had a strong ‘imagined sameness’.

“When Norway was the pure nature and it was called- not small trolls@ but ##01:32:26 a land with mythical and super Norwegianess,” (line 3-4).

Helen is comparing the ’94 winter Olympics spirit to contemporary Norwegian society. She says that 20 years ago was a cleaner, more pure and exceptionally “super” Norwegian time.

Helen appears to be saying that although ethnic Norwegians own national sentiment, they do not want to be called ‘nationalists’ and that reflects Helen’s reaction to a commonly held belief that ethnic Norwegians are nationalistic. This excerpt suggests Helen is drawing indirectly on the interpretive repertoire of ‘whiteness’ is pure in that Helen introduces this ‘era’ of cleanliness and purity as a time where Norway was not “multi-ethnic”

(multiculturalism threatens Norwegian tradition). Helen refers to the fact that the Norwegian population has become more heterogeneous and the expression of a ‘super’ Norwegian national sentiment has become stigmatised. As Norway becomes more multicultural, the risk of being perceived as nationalistic by other countries increases.

### *Norway is a ‘white space’ (1 excerpt)*

This interpretive repertoire implies an entitlement to ethnic Norwegian ownership of the physical and cultural space of Norway.

### Colloquia

1 Tone: Adoptiv barn eller- som kommer fra samme land? Med-

2 Christine: [Ja]

3 (5.0)

4 Tone: Skal vi si det går jo veldig myche asså utpå rasen sant? Eller-

5 (Kvalitativt59:34) er det veldig gjerne- de føler seg fremmed for eksempel i det

6 norske samfunn fordi de blir- de ser annerledes ut men de er norsk egentlig så- det

7 har veldig myche med etnisk tilhørighet ###59:45.

Translation:

1 Tone: Adopted children or- that come from the same country? With-

2 Christine: [Yes]

3 (5.0)

4 Tone: Shall we say that it greatly depends on the race right? Or- (Qualitative59:34)

5 is very possible- they feel like strangers for example in the

6 Norwegian society because they become- they look different but they

7 are actually Norwegian so- it greatly depends on ethnic belonging ###59:45.

20/09/13

Time: 59:30

The class is discussing what the sense of ‘home’ must be for adopted racialised children who now live in Norway with Norwegian parents. Just prior to the quoted excerpt, Christine brought up the idea of adopted children feeling an incomplete belongingness to Norway. The implication is although adopted children are not related to any specific diaspora, they may feel like they are incapable of reaching the level of societal membership ethnic Norwegians have from birth.

This exemplifies the impact of both biological and cultural essentialism on determining the degree of national and cultural belonging. Tone suggests ethnic belonging “greatly depends on race” (line 4). Tone is suggesting the level of belonging to the Norwegian society is related to how different the individual looks from the typical Norwegian, thus geographic origin and skin-colour of the adopted child plays a significant role. This connects to the interpretive repertoire Norway is a white space.

***National/cultural membership is extended to select ‘honorary whites’ (1 excerpt)***

‘Honorary whites’ are defined as non-whites, who, through exceptional talent or accomplishment, gain a valued social status, and may thereby be partially protected from racial discrimination.

Lecture: Professor A

1 Kari: Men det er ofte med det hvis det er noen med en annen hudfarge som gjør  
2 noe- kriminelt så blir det omtalt som om et litt sær innvandrere  
3 Rolf: [det kan godt være ja]  
4 Kari: Og hvis det er en fotballspiller som gjør det topp, så er han norsk  
5 Rolf: [Da er han norsk]  
6 Class: @@@

Translation:

1 Kari: But it is often that if someone with a different skin-colour does something-  
2 criminal, they will be portrayed as a somewhat strange immigrant  
3 Rolf: [That may well be]  
4 Kari: And if there is a football player who excels, then he is Norwegian  
5 Rolf: [Then he is Norwegian]  
6 Class: @@@

30/08/13

Time: 39:00

The interpretive repertoire of national/cultural membership being extended to select 'honorary whites' refers to the limited opportunity for the average non-white to attain the privileges and rights to which white people feel entitled. The example that Kari provides describes the tendency for ethnic Norwegians to either stigmatise non-whites as 'strange immigrants' or hail them as 'honorary white' Norwegians. This is a significant perspective because Kari is a person of colour and in this context is therefore a voice from the disadvantaged receiving end of stigmatised racialisation. Her use of "different skin-colour" assumes white is 'normal' and the dominant skin-colour in Norway. The example suggests that in order for a person of colour to gain approval as an 'honorary white', they have to demonstrate their value by extraordinary achievement. This would create a sense of national pride for ethnic Norwegians, who can share in the achievement. In this case, an outstanding racialised football player qualifies as an 'honorary white' Norwegian.

Kari draws upon the interpretive repertoire of national/cultural membership is restricted to ethnic Norwegians given that ethnic Norwegians can 'approve' of persons of colour becoming 'honorary whites' (Norway is a 'white space'). 'Whiteness' is pure emerges as an interpretive



repertoire, in that it is assumed that becoming an ‘honorary white’ is an achievement and indicates white Europeans are civilised, by placing ‘whiteness’ or ‘Norwegianess’ on a pedestal to which persons of colour should strive. The Norwegian quote from Gro Harlem Brundtland’s campaign motto, “Det er typisk norsk å være god” [It is typical Norwegian to be good] alludes to the broad definition of ‘good’ ranging from moral to talented and gives the impression this is what can be achieved if people of colour as well as white immigrants become ‘good enough’ to meet the requirement (imagined sameness).

***White Europeans are colonialists (1 excerpt)***

This interpretive repertoire implies that white Europeans are identified by and associated with traditional colonial European territorial expansion policies, including the implications for the indigenous people.

Lecture: Professor A

1 Professor: Når kristne dukker opp så er det først og fremst ofre minoriteter og de  
2 svakeste minoriteter blir ofret først.

Translation:

1 Professor: When Christians show up, it is first and foremost the minorities who are  
2 sacrificed and the weakest minorities are sacrificed first.

30/08/13

Time: 34:00

It is important to clarify this is the perspective of the non-ethnic Norwegian professor. The professor is alluding to Christians arriving in new geographic locations when he says, “when Christians show up,” (line 1). This is in reference to colonialism and the expansion of Christianity through cultural assimilation, which draws from white Europeans are colonialists and white people feel entitled to privilege and authority. There is an assumed perception of superiority when one culture imposes their rule of law in a ‘top-down’ approach upon an encounter with another culture (cultural essentialism). The non-European native civilisations have historically not survived Christian encounters without compromising their culture

(civilised vs. savage). This draws on the interpretive repertoire that the nature of colonialism is violent.

The professor continues to state the first thing to occur upon encounters with other cultures is the sacrifice of minorities, implying cultural assimilation, not integration. What constitutes a 'weakest' minority in this context? Non-whites? One can assume the colonialists were the minorities, if the term is used to define the size of the population of people on each side of the cultural encounter. However, if the term 'minority' is describing the power of 'non-whites,' then the word itself is an extension of global colonialism, in which the majority means not necessarily the size of the population, but the authoritative power.

## **5.2 Norwegian Ethnicity**

Similar to 'Whiteness' appearing to be related to being a 'true' Norwegian, ethnicity is observed as a fundamental component to national belongingness. Being ethnic Norwegian implies the race designation of white skin. This is conceivable considering the previous long-lasting homogeneity of Norway. However, in a nation in multicultural transition, this potential visual marker for citizenship may act as an invisible restriction on the sentiment of national membership. Unless immigrants feel they are receiving mutual respect from their new community, there may be limited incentive to integrate into Norwegian society and its lifestyle.

### ***Norwegian ethnicity interpretive repertoires:***

Examples that were identified during data analysis are:

Ethnic Norwegians are moral and non-violent - Norwegians consider themselves fortunate -

Multiculturalism threatens Norwegian tradition - Ethnic Norwegians are nationalists -

National/cultural membership is restricted to ethnic Norwegians - Ethnic Norwegians are

possessive of their national celebration - Adopted children are ethnic Norwegian - Adopted children are not ethnic Norwegian - Assimilation means improving your status - Assimilation means sacrificing your identity

***Ethnic Norwegians are moral and non-violent (2 excerpts)***

This interpretive repertoire draws from the traditional Norwegian reputation as a peaceful and affluent yet politically and morally responsible, diplomatic democracy.

Colloquia

1 Helen: Eg har levd med to for- eg har: veldig mange fra Kina som er adoptert.  
2 Akkurat nå bur jeg med ein som var adoptert fra Colombia.

Translation:

1 Helen: I have lived with two for- I have: very many from China who are adopted.  
2 Right now, I live with one who was adopted from Colombia.

27/09/13  
Time: 58:14

Helen is taking on the role as the ‘good Norwegian’ by emphasising “I have many from China who are adopted.” This excerpt implies that Helen identifies herself as a social philanthropist who has taken ownership over the status as the ‘carer’, maintaining her role as the ‘protector’ of the ‘new guests’ in Norway. This connects to the interpretive repertoire of ethnic Norwegians are moral and non-violent, Norway is a ‘white space’, adopted children are not ethnic Norwegian and national/cultural membership is restricted to ethnic Norwegians, (imaged sameness).

“Right now, I live with one adopted from Colombia,” (line 2). The use of “Right now” could be interpreted as Helen seeing her relationship with adopted Norwegians as temporary or strengthening her views by demonstrating her experience. Helen appears to have taken possession over her adopted housemates, in a way that might be more relatable to a child’s

need for protection (civilised vs. savage). Helen's mention of their countries of origin gives rise to the perspective that Helen has become exotic by association and immersed in this issue, appearing to have improved her status through this process. The way in which Helen refers to her friends' countries of origin suggests she views her relationship with adopted Norwegians as socially beneficial (interest convergence). Thus, Helen appears to be drawing from white Europeans are civilised, ethnic Norwegians are innocent of racism, white people feel entitled to privilege and authority.

### Colloquia

1 Helen: Men vi nordmenn feirer oss sjøl med den tanken at ja men vi har  
2 barnatog- vi har ikke militære parader- vi er jo en av de få landene  
3 Erik: [Mhmm]  
4 Helen: i verden kor vi feirer nasjonaldagen- vi ikke har en konge eller en  
5 president som da ###01:45:14 store militær parade da for å vise  
6 alle våre våpne å- vi har jo ikke våpen så det @@@

Translation:

1 Helen: But we- Norwegians, celebrate ourselves with the thought that, well yes, we  
2 have a children's parade- we don't have military parades-. we are one of the few countries  
3 Erik: [Mhmm]  
4 Helen: in the world where we celebrate our Independence Day-we don't have a king  
5 or a president who then gives a #####01:45:14 large military parade to show off our  
6 weapons- we don't even have weapons so @@@

27/09/13

Time: 01:44:50

Helen is explaining that Norway's unique celebration of its Independence Day indicates the extent of Norwegian national moral identity. National pride is not based on military capabilities, but rather on children. Helen shares, "But we- Norwegians, celebrate ourselves with the thought that, well yes, we have a children's parade- we don't have military parades-." Here, Helen explains this is one day a year where Norwegians openly celebrate themselves as good people (imagined sameness). Helen emphasises the Norwegian 'goodness' by contrasting Norway with the rest of the world as a country, which prioritises their children on the day of national independence rather than the demonstration of military power.

Helen continues, "...we are one of the few countries in the world where we celebrate our Independence Day- we don't have a king or a president that then gives a 01:45:14 large military parade to show off our weapons- we don't even have weapons so @@@," (line 4-6). Helen is again comparing Norway to the rest of the world as one of the few countries that does not centre around a king or president's speech, showing off their military capabilities because, as Helen puts it, "we don't even have weapons," (line 5-6). Helen is indicating that not only does Norway not show off their military weaponry, Norway doesn't have any weapons to show off, suggesting other countries are inherently violent (civilised vs. savage). This is important, because there is a difference between choosing not to use the Independence Day to show off the Norwegian military and having no military to display. This draws from the interpretive repertoire that ethnic Norwegians are moral and non-violent. However, Norway is a member of NATO, which has military capabilities across the majority of international borders, including Norway. This represents interest convergence, since Norway is in fact a militarily active nation and an international exporter of weapons manufacturing products, while effectively portraying itself as a fundamentally peaceful nation. In this sense, an ideological dilemma emerges; a peace-loving nation producing and selling weapons.

### *Norwegians consider themselves fortunate (3 excerpts)*

This interpretive repertoire refers to Norwegians' awareness of the benefits of living in Norway. It also implies an appreciation of the privileges and good fortune resulting from their birth right.

### Colloquia

1 Helen: Nei ho som æ bodde me pleier-det er litt 01:00:36 å høre om det fordi det  
2 er noen som har akkurat den følelsen at  
3 dem har blitt forlatt men nå 01:00:49 i tipping 01:00:50 jackpotten  
4 at "æ hatt to norske foreldre som ønske å adoptere mæ i tillegg til  
5 at hvor jeg var satt bort- på barnahjemmen periode-"

Translation:

1 Helen: No, she who I lived with used to- it's a little ###01:00:36 to hear about it  
2 because it is someone who has that specific feeling that they have been abandoned  
3 but now ###01:00:49 in betting ###01:00:50 the jackpot that "I have two  
4 Norwegian parents that want to adopt me in addition to that I was placed away in a  
5 foster home."

27/09/13

Time: 01:00:30

Helen talks about her experience living with an adopted girl. Helen explains the girl will sometimes confide in her about her feelings of being abandoned and how she won the "jackpot" because she now has two Norwegian parents that wanted to adopt her. Helen explains the girl would compare her life in Norway to the one before she was adopted, giving details about her experience in the sub-par living conditions of the foster home (civilised vs. savage). Here, Helen pulls from the interpretive repertoire of ethnic Norwegians are moral and non-violent in that the Norwegian parents are placed in the light of the 'saviour'. This story draws upon the interpretive repertoires that Norwegians consider themselves fortunate, since even adopted Norwegians feel the benefits of living in Norway. Helen also draws upon white Europeans are civilised because Helen's contrast between the girl's life now and life then suggests she has been 'rescued' into a superior standard of living, where she can enjoy her 'winnings' as an adopted Norwegian.

### Colloquia

1 Heidi: Æ tror æ setter mer pris på det fordi jeg har bod utenlands.

2 Alice: Ja akkurat.

3 Erik: Ja

4 Heidi: Åså snakket vi om ikke sant at e etnisktilhørighet holdt jeg på å si oppleves

5 fyst sterkt når du er i møte med andre-

Translation:

1 Heidi: I think I appreciate it more because she has lived abroad.

2 Alice: Yes, exactly.

3 Erik: Yes

4 Heidi: And then we discussed the sentiment of ethnic belonging, right? It is

5 experienced first strongly when you encounter others-

27/09/13

Time: 01:36:28

Heidi expresses to her classmates that she had rediscovered her value for Norway only once she had left the country. She concludes one can only truly experience their ethnic belonging once they have encountered other countries or cultures. This suggests that only after Heidi compared Norway to her experience with other countries, that she understood how fortunate she was to be Norwegian. This draws on the interpretive repertoires of Norwegians consider themselves fortunate, alluding to ethnic Norwegians are nationalistic, in that once ethnic Norwegians have travelled abroad, they acknowledge and revere their ethnic belonging to Norway (imagined sameness).

### Colloquia

- 1 Heidi: For eksempel venninen din sier
- 2 Erik: [Ja]
- 3 Helen: [Mhmm]
- 4 Heidi: hun har vunne lotto sant? Kor ofte tenker vi på det? Det er som dere- fin
- 5 Helen: [Ja men det er jo en helt annet--]
- 6 Heidi: tanke man har i jul- rundt jul så snakker vi om det-

Translation:

- 1 Heidi: For example when your friend says
- 2 Erik: [Yes]
- 3 Helen: [Mhmm]
- 4 Heidi: she has won the lotto right? How often do we think about that? It is as if you-
- 5 Helen: [Ja but that is a whole different--]
- 6 Heidi: thought people have in Christmas- around Christmas, then we talk about it-

27/09/13

Time: 01:38:00

Heidi uses Helen's example of her adopted friend feeling she had won the 'jackpot' by living in Norway. She then reflects with the class how often "we" think about it. Then Heidi asserts that Helen's adopted friend's perception is real by saying the benefits of ethnic Norwegian privilege and belonging are only properly considered around Christmas, one of the only annual times of designated reflection. Heidi's example describes the idea that ethnic Norwegians might be taking their 'fortune' for granted. However, this only emphasises the

existence of Norwegian fortune to begin with, which relates to the interpretive repertoire of  
Norwegians consider themselves fortunate.

***Multiculturalism threatens Norwegian tradition (2 excerpts)***

This interpretive repertoire suggests that the increased diversity and exposure to alternative cultures resulting from increasing multiculturalism threatens to dilute the preservation of Norwegian traditions.

Lecture: Professor A

- 1 Professor: Eh- ofte sånn kanskje litt enkelt eksempel på eh- en ofte komt at snart
- 2 norsk mat forsvinner.
- 3 Altså den mat tradisjonen også blir kanskje altså truet av den global mat
- 4 tradisjonen.

Translation:

- 1 Eh- often maybe a little simplistic example on eh- that often comes up
- 2 that soon Norwegian food disappears.
- 3 Meaning that the food traditions maybe also threatened by the global culinary
- 4 tradition.

30/08/13

Time: 01:01:20

The non-ethnic Norwegian professor is using an example that emphasises the sense of uncertainty and insecurity for Norwegian food's future in light of multiculturalism and the inevitable cross-cultural encounter it involves. The professor is portraying ethnic Norwegians as being threatened by an intrusion on their cultural values, such as their traditional food.

As mentioned previously, Integration means to foster a new identity in addition to the previous preserved one(s), while in contrast, assimilation refers to the replacement of an identity with another. Here, Norwegian food appears to be going through an assimilation process. The professor draws on the interpretive repertoires of assimilation means sacrificing your identity as opposed to assimilation means improving your status, suggesting that Norway is displayed on the sacrificing end of cultural assimilation. Here, the professor draws from the



interpretive repertoire that multiculturalism threatens Norwegian tradition. The slow erosion of Norwegian culinary traditions, a connotation that the culture is being ‘swallowed’, further indicates this. This is unique, because it appears to serve as one of few examples from the four transcripts in which a white and dominant group feel under threat from an outside influence (cultural essentialism). This relates to the interpretive repertoire that Norway is a white space.

## Colloquia

1 Heidi: Men det som jeg syns er så leit er når du har denne her menningstømningen  
2 så bytter vi en ting med noe som blir mer hypa  
3 sånn som gå julebukk er en kjempe gammel norsk tradisjon- kjempe  
4 gammel- åså har konseptet Trick og Treating-  
5 Ruthie: Urgh Ja  
6 Heidi: Det- det liksom mye mer- de ser på tv og de ser det i reklamar  
7 å det er enklere for butikkene å gjere seg nytta av romjulen når  
8 butikken er stengt- det er en god del som VOX<å nei nei da bytter vi sånn  
9 Class: [Mhmm]  
10 Heidi: kjempe fin tradisjon og så bare Amerikaniserer vi mer så->VOX.  
11 Tone: Men vi har det samme med Halloween også-  
12 Heidi: Det er jo Trick og Treating @  
13 Class: @@  
14 Tone: Men [dere ser jo-]  
16 Heidi: [Æ syns det er utrolig] trist fordi det syns æ var kjempe koselig  
17 sant? Når vi var små: også lagde disse her- og skulle kle oss ut som  
18 onklige nisser med mose i håret - eg hadde jo enda lengere hår da men nå  
19 Ruthie: [Mhmm]  
20 Heidi: så det var helvete å få løysa-  
21 Class: @@  
22 Heidi: Så det-  
23 Erik: Det er noen som går i julebukk ###33:16  
24 Heidi: hmm?  
25 Erik: Det er noen som går i julebukk fremdeles sant?  
26 Heidi: Jo men aså nå oppdager du mye at når folk- når ungane banker på  
27 og går i julebukk så risikerer du at i kanskje fem av ti hus så står folk  
28 liksom VOX<Ka du vil?>VOX  
29 Erik: [Åja k]  
30 Helen: Eller åpner bare rett og slett ikkje døra-  
31 Heidi: Ja-

### Translation:

1 Heidi: But what I think is so sad is when you have this ‘meaning’s purge’  
2 so we exchange one thing with another which becomes more hyped up  
3 like to walk in Julebukk (Norwegian Christmas carols) is a really old Norwegian  
4 tradition- really old- so now, the concept of Trick or Treating-  
5 Ruthie: Urgh yeah  
6 Heidi: It’s like, more than that- they look at T.V. and they see advertisements and  
7 how much easier it is for shops to take advantage of Christmas time when the shops  
8 are closed- there are a good deal of people who say ‘oh no no, then let’s replace a  
9 really nice tradition and just Americanise it more so-  
10 Tone: But we have the same thing with Halloween too.

11 Heidi: That is Trick or Treating @  
12 Class: @@  
13 Tone: But [you guys see my point-]  
14 Heidi: [I think it's unbelievably sad] because I think it was really cosy,  
15 right? When we were small, and made these- and we would dress up like proper  
16 'elves' with mousse in our hair- I had even  
17 longer hair then but now, it was hell to loosen up-  
18 Class: @@  
19 Heidi: So it was-  
20 Erik: There are still people who go on Christmas Carols.  
21 Heidi: Hmm?  
22 Erik: There are still those who will go on Christmas Carols, right?  
23 Heidi: Yes, but recently you notice more that people- when children knock on the  
24 door and go on Christmas Carols you risk maybe that at five out of ten houses,  
25 people will just stand there like VOX<What do you want?>VOX  
26 Erik: [Oh ok]  
27 Helen: Or just won't open the door-  
28 Heidi: Yeah-

27/09/13

Time: 32:50

The class is discussing how Norway is going through an Americanising process.

Heidi's use of the words "so" to describe "so sad" in line 1 and repetition of "really" to describe how "really old" the Norwegian tradition of Julebuk is (line 3-4). This suggests Heidi feels time has weakened the link between Norwegians and their value of Norwegian tradition. This also indicates time itself, is a significant influence on the value of a tradition. Ruthie's interruption suggests she agrees the 'Americanised' assimilation of the Norwegian tradition of 'Julebuk' is superficial.

Heidi explains the issue she has with "Trick or treating", "...they look at T.V. and they see advertisements and how much easier it is for shops to take advantage of Christmas time when the shops are closed- there are a good deal of people who say 'oh no no, then let's replace a really nice tradition and just Americanise it more so-," (line 6-9). Heidi is confronting the issue of consumerism overtaking the priority of traditional Norwegian community. The criticism of 'Americanising' Norwegian traditions appears to be the disconnect of Norwegian unity and fading of an 'imagined sameness' within the national borders.

Heidi continues, “I think it’s unbelievably sad because I think it was really cosy, right? When we were small, and made these- and we would dress up like proper ‘elves’ with mousse in our hair- I had even longer hair then but now, it was hell to loosen up,” (line 14-17). Heidi is reminiscing about the nostalgic memories that helped shape her Norwegian identity. Now, she is expressing her discontent for superficial consumerist holidays replacing a central Norwegian tradition.

Heidi exemplifies her sentiment that Trick or Treating might be intimidating the sense of the Norwegian cultural community by emphasising, “Yes, but recently you notice more that people- when children knock on the door and go on Christmas Carols you risk maybe that at five out of ten houses, people will just stand there like VOX<What do you want?>VOX,” (line 23-25). Helen adds, “or they will just not open the door,” (line 27).

Heidi is explaining that 50% of Norwegians are now possibly unaware of what ‘Julebuk’ entails. Furthermore, Helen’s comment explains the notion that a sense of community is being lost. This draws from the interpretive repertoire that national/cultural membership is restricted to ethnic Norwegians because the impression is there is a correlation between the process of multiculturalism in Norway and the loss of identity, meaning that Norway is a white space, specifically designated for ethnic Norwegians and their ‘imagined sameness’.

### ***Ethnic Norwegians are nationalists (1 excerpt)***

This interpretive repertoire suggests ethnic Norwegians have strong nationalistic traditions that may serve to indirectly promote exclusionary practices, marginalising non-ethnic Norwegians.

### Colloquia

1 Helen: Jeg må bare spørre ka var dit inntrykk første gang du feira syttende mai  
 2 i Norge?  
 3 Tone: Jeg pekte meg litt ut for jeg gikk rundt i en knallgul eh: reinjakke-  
 4 Class: @@  
 5 Tone: Så tenkte jeg oi, trudde jeg var i et annet land-  
 6 Class: @@  
 7 Tone: Det var- det var ikkje ubehagelig- det var litt morsomt å se på fordi  
 8 jeg hadde ikke sett på- jeg va ikkje med i Oslo eller ###01:44:03 men litt  
 9 Helen: [Ja:]  
 10 Tone: spesiell er den ###01:44:04 galskapen.  
 11 Helen: Men ka var det du reagerte mest på- ikke den- reagerte du mest på  
 12 flaggbruken, reagerte du med at folk var så pen kledd å hatt på bunad å sånn?  
 13 Tone: Kanskje mer det.  
 14 Helen: Med bunad @  
 15 Tone: Ja men den reaksjonene gikk mer på at eg prøvde litt å vurdere hvorfor er  
 16 man så glad men den tenkte jeg først aha det er egentlig ganske fint at man  
 17 Helen: [@]  
 18 er så glad å være en veldig ung nasjon- samfunn- ###01:44:42  
 19 Heidi: [Mhmm]  
 20 men samtidig er det også veldig ganske naive ting -som- er bak den-

Translation:

1 Helen: I just have to ask, what was your impression the first time you  
 2 celebrated the 17<sup>th</sup> of May in Norway?  
 3 Tone: I singled myself out a little because I walked around in a bright yellow eh:  
 4 rain jacket.  
 5 Class: @@  
 6 Tone: Then I thought oh, I think I'm in another country-  
 7 Class: @@  
 8 Tone: It was- It wasn't uncomfortable- it was a little funny to observe because I had  
 9 not seen- I had not attended in Oslo or ###01:44:03 but a little  
 10 Helen: [Yes:]  
 11 Tone: special is that ###01:44:04 madness.  
 12 Helen: But what was it you reacted mostly to- not the- did you react mostly to the flag  
 13 usage or did you react to the people dressed up with their bunad on and stuff?  
 14 Tone: Maybe more that.  
 15 Helen: With the bunad @  
 16 Tone: Yes but that reaction was more based on trying to evaluate why people were  
 17 so happy but then I thought aha it is actually quite nice that people  
 18 Helen: [@]  
 19 Tone: are so happy to be a very young nation-society- ###01:44.42  
 20 Heidi: [Mhmm]  
 21 Tone: but simultaneously, it is also a quite very naive thing that stands behind it.

27/09/13

Time: 01:44:35

Helen directs a personal question to the German colloquia leader Tone, “ I just have to ask, what was your impression the first time you celebrated the 17th of May in Norway? (Norwegian Independence Day),” (line 1-2). By initiating the question with ‘I just have to ask’ reveals the inquiry is structured in a way that features an invested curiosity for Tone’s response.

Tone's reference to feeling "singled out" (line 3) by wearing a bright yellow raincoat suggests she was becoming a witness to the exclusionary side of the Norwegian cultural value of 'imagined sameness'. This continues when she mentioned she felt she was in another country and the class laughter following this statement infers in this context the class agrees. Tone was surprised by the level of national pride, she said it was not "uncomfortable" but "funny", a strange experience (line 8). Tone is German and her reference to the day as being "madness" (line 11) indicates her reaction to a perceived irrational attitude toward nationalism.

Helen's question directed at what Tone reacted to the most that day suggests an overall reaction was not enough, Helen wanted to know whether the reaction was related to nationalism (flag usage), unity (dress code) or cultural values (tradition). Tone responded that her reaction was not negative, stressing she was not judging ethnic Norwegians on their behaviour, suggesting she was not disappointed but surprised or concerned. This is significant in light of Germany's history of patriotic nationalism. Tone is sensitive to the contrast in the tone of expressions of national pride between the two nations.

Tone evaluated her reaction to why ethnic Norwegians were so happy on the 17th of May, but then came to the conclusion that Norway is an 'innocent' young nation with a relatively benign recent history. However, Tone mentions that it is naïve to be nationalistic. Especially when an outsider interprets the right to express national pride appears in practice to be limited to ethnic Norwegians.

***National/cultural membership is restricted to ethnic Norwegians (2 excerpts)***

This interpretive repertoire implies that ethnic Norwegians identify themselves as the exclusively eligible, entitled members of their nation.

## Lecture: Professor A

- 1 Professor: hvor du kommer fra?
- 2 Han sier fra Bergen.
- 3 Men eg bare sånn, eh- du ser ikkje fra Bergen.
- 4 -Jo Jo sier han, jeg er vokst.

Translation:

- 1 Professor: Where do you come from?
- 2 He says from Bergen.
- 3 But I'm kind of like- you don't look like you're from Bergen.
- 4 Yes, yes he says, I was raised here.

30/08/13

Time: 36:00

The professor from this lecture is a non-ethnic Norwegian living in Norway. In this excerpt, he describes a conversation he has frequently. It is interesting that he is asking a fellow immigrant where he comes from. The example demonstrates the professor is adopting the ethnic Norwegian's curiosity about ethnicity, which could appear intrusive. The fact that being raised in Bergen does not qualify for national membership, suggests that physical traits are most important to Norwegian identity.

In this example, the professor is sharing an experience he had where he asked someone "where do you come from?" The man responded that he was from Bergen, but the professor replied, "you don't look like you're from Bergen," indicating that to look like you are from Bergen is to look white (biological essentialism). The man retorted, "Yes, I was raised here." In other words, the man in the example explained that although he didn't fit into the category of a Bergen local, he was an exception that qualified through his duration and experience as opposed to skin-colour (Norway is a white space). Saying he was raised in Bergen suggests he was sharing he was integrated into the Norwegian society and therefore, considered himself both Norwegian and from Bergen. It is interesting that the man does not reveal his foreign ethnicity, only his definition of 'home'. Revealing it might weaken his claim to being

Norwegian by being perceived as possibly distancing himself from Norwegian identity and belongingness (assimilation means going up in status).

### Lecture: Professor A

1 Professor: Eh- det er også ganske interessant å se e- selv om du har bodd her i  
2 ganske lenge sant, så men allikevel så de spør deg hvor du kommer fra sant?  
4 I det personlig men med det daglig blir jeg spurt hvem er jeg ikke sant?  
5 H-hvor du kommer fra?  
6 Det er alltid en bevisst ###38:28 akkurat som et knapp ikke sant med  
7 en gang du ser de standard setningene ikke sant hvor du kommer fra.  
8 Men det er naturlig også og av og til blir veldig glad å bli spurt fordi du føler  
9 at du blir sett.  
10 Altså det er trist du ikke blir sett: heller sant?  
11 Så derfor så av og til er det altså (viser det seg38:40) ganske også  
12 positivt, gjør alt og husker-husker noe sant? Altså blir minnet  
13 på den måten.

Translation:

1 Professor: Eh- what is also interesting to see is- even when you have lived here quite  
2 long, right?, still, they ask you where you come from, right?,  
3 In that personally, but daily I am asked who I am, right?,  
4 Where do you come from?  
5 There is always an awareness ###38:28 just like a button, right?,  
6 Right when you see the standardised sentences, right? Where do you come from.  
7 But it is also natural once in a while to be very happy to be asked because you feel  
8 that you are seen.  
9 Meaning it is sad not to be seen, isn't that right?,  
10 so therefore once in a while it represents something quite positive, do  
11 everything and remember some of it, right?, Basically, reminded of that way.

30/08/13

Time: 38:01

The professor weighs the sense of unintentional racial discrimination against the feeling of not being seen. “Even if you have lived here quite long, right?, still they ask you where are you from, right?,” (Line 1-2). Living in Norway quite a long time suggests successful integration into the Norwegian culture. Yet, ethnic Norwegians still have the tendency to ask about origin. This suggests that the concept of ‘imagined sameness’ goes beyond identifying with Norwegian cultural values and includes also looking Norwegian as well.

“...I will be asked whom I am, where I’m from on a daily basis,” (line 3-4). The question ‘Who are you’ implies a curiosity into the full identity of the person. This level of identity

might include a link to the ‘nationality of origin’; suggesting ethnic Norwegians are defined by the full membership of only one nationality. This restriction on identity might lead to the perspective of cultural essentialism, which proposes people are fundamentally determined by their cultural origin.

“There is a conscious ###38:28 just like a button right?, (line 5). The use of the word ‘button’ indicates a conditioned response to the standardised sentences. The approach of asking ‘where do you come from’ is common enough to the point where it is nearly predictable. However, sometimes it is a positive experience because one feels their individuality is being acknowledged, “It’s sad when you are not seen, right?...” (Line 9).

According to the professor, ‘colourblindness’ is an ineffective approach to anti-racism. Colourblindness may serve to actually further isolation because the racialised individual might feel invisible and undervalued. The insistent investigation of the geo-cultural origins of immigrant people of colour by the dominant white Norwegian population reveals a sense of entitlement of Norway’s public area as ‘white space’ (Norway is a white space) that encourages potential intrusions of privacy in the name of ‘oblivious’ curiosity.

### ***Ethnic Norwegians are possessive of their national celebration***

This interpretive repertoire describes how ethnic Norwegians may discourage attempts to make Norwegian Independence Day multicultural and protect the symbol of their national celebration.

#### Colloquia

- 1 01:35:33 (859-863) Ruthie: Men vi har jo Samene-
- 2 Helen: [Men vi har jo egen dag ikke sajtnt?] ###01:35:14-18.
- 3 Syttende mai ###01:35:22 og det var sånn VOX< Ja men dokker e jo egen dag
- 4 Ruthie:[Mhmm]
- 5 Helen: du få ta med flagget da>VOX @@

Translation:



1 Ruthie: But we have Sami people-  
2 Helen: [But they have their own day, right?] ###01:35:14-18.  
3 The 17<sup>th</sup> of May ###01:35:22 and it was like VOX<Yes but you all have your own  
4 day  
5 Ruthie: [Mhmm]  
6 Helen: you can bring your flag then>VOX @@

27/09/13  
Time: 01:35:33

Ruthie explains “But we have Sami people,” where “we have” elicits the assumption she considers herself as an entitled member of the predominant Norwegian society. The use of “we” separates her from the Sami people and implies a degree of ownership and dominance. “We” may also be interpreted as Ruthie considering her nationality and country indistinguishable saying that ‘we, Norwegians have Samis’ or ‘We, Norway have Samis’. Of course, Samis are also Norwegian citizens with the longest human history in these geographical areas. This draws upon the interpretive repertoire of national/cultural membership is restricted to ethnic Norwegians and ethnic Norwegians are nationalists. The first interpretation suggests Ruthie is speaking on behalf of Norwegians and indicates a degree of possession and ownership over the Sami people. They are not portrayed as ethnic Norwegians, when in fact they are the indigenous Norwegian population. The second interpretation is indicative of the view that ethnic Norwegians do not separate themselves from the physical geography of Norway. The perception is that Norway and ethnic Norwegians are inter-related; suggesting Norway is a white space (imagined sameness).

Sami people became racialised, marginalised and excluded from equal opportunity. In the 19<sup>th</sup> century, an example of this was the Norwegian government knew the value of agricultural independence for the Sami population and sabotaged their sovereignty by prohibiting the Sami people the right to horses, which played crucial roles in the success of farming. Helen continues this thought “We have our own day, right?” meaning that all Norwegian citizens are

expected to celebrate the Norwegian Independence Day and wave only the Norwegian flag. Helen argues this day is about unity, not individuality (imagined sameness). That said, Helen explains the Sami population do in fact have their own day to celebrate, which is the designated opportunity for them to represent their flag. Although the 17th of May is a high profile festivity where Norwegians are encouraged to fully celebrate their independence, the Sami Independence Day has limited national coverage and is not seen as a celebration of their Norwegian identity.

This discourse describes how Norway is a white space, where although the Sami population does not differ significantly from Norwegians in skin-colour, they are racialised as the ‘other’ when compared to ethnic Norwegians. This excerpt draws upon the interpretive repertoires that cultural/national identity is restricted to ethnic Norwegians as well as ethnic Norwegians are nationalists given that Helen is taking the stance that the 17th of May should be strictly a Norwegian celebration.

### ***Adopted children are ethnic Norwegian (2 excerpts)***

This interpretive repertoire suggests that the term ‘ethnic Norwegian’ may extend to children born outside of Norway and subsequently adopted by ethnic Norwegian parents.

### Colloquia

- 1 Ruthie: Eg har en venn som har to adopterte barn fra Korea eh: å dei er
- 2 jo fullstendig klar over at de kjemmer fra Korea sant?, og når de har
- 3 internasjonal dag på skulen så tar de initiativ sjøl å ta me
- 4 seg den koreanske flagget å de veit veldig myche om heimlassen
- 5 sin å- eller- landet sitt då- men de er kanskje for unge for å snakker
- 6 Tone: [Mhmm]
- 7 Ruthie: meir om eh: foreldre bakgrunnen og koffer de har blitt adoptert
- 8 men de veit jo- de er klar over at de kjem fra Korea.
- 9 Tone: Mhmm.
- 10 Ruthie: Men om de er då-((smiles)) de er vel etnisk norske fyst og fremst.

Translation:

- 1 Ruthie: I have a friend who has two adopted children from Korea eh: and they are
- 2 fully aware that they are from Korea right?, and when they have ‘international day’

3 at school, it's their own initiative to take the Korean flag and they know a great  
4 deal about their homeland 4 and- or- their country then- but they are perhaps too  
5 young to talk about

6 Tone: [Mhmm]

7 Ruthie: more about eh: their parents' background and why they are been  
8 adopted but they know- they are aware that they are from Korea.

9 Tone: Mhmm.

10 Ruthie: But if they then- ((smiles)) they are ethnic Norwegians first and foremost.

27/09/13

Time: 57:20

Ruthie is sharing a story about two ethnic Norwegian friends who have adopted two young Korean children. She explains, “they are perhaps too young to talk more about eh: their parents' background and why they have been adopted but they know- they are aware that they are from Korea,” (line 6-7).

Similar to Helen's example, she alludes to successful assimilation into Norwegian society at an early age can potentially qualify as the process of becoming ethnic Norwegians. This perspective draws from the interpretive repertoire national/cultural membership is extended to select 'honorary whites', such as very young adopted children. These children may be included in the cultural 'imagined sameness' but not the biological aspect because of their visual differences. This relates to white Europeans are civilised since the children might consider membership into Norwegian civilised society as an 'honour' (civilised vs. savage). This ties into the interpretive repertoire that Norwegians consider themselves fortunate.

In this excerpt, Ruthie proposes a similar suggestion. The children appear young enough for a successful cultural assimilation into Norwegian society, in which their skin-colour 'visibility markers' are the final reminders of a distant past that no longer applies. This could be why Ruthie concludes by saying, “But if they then- ((smiles)) they are ethnic Norwegians first and foremost,” (line 9) (adopted children are ethnic Norwegian).

Ruthie implies if adopted children can detach themselves from their cultural origins, they may be eligible to ethnic Norwegian membership (cultural essentialism). This links to the interpretive repertoire that ethnic Norwegians are moral and non-violent, since both Helen and Ruthie appear to give the impression that differing skin-colour from white, ethnic Norwegians is tolerable, contingent on that being the only salient difference between them. This excerpt suggests ethnic Norwegians prescribe to cultural essentialism while dismissing biological essentialism as inconsequential.

### Colloquia

1 Helen: han skal adopter- någe identitet eller kulturell identitet  
2 eller ###58:55 sæ tradisjoner fra det landa som dei da e født i  
3 i dag- livet sett som nordmenn i dag det eineste som gjør at  
4 dem er forskjellig fra- meg for eksempel det er jo det kanskje-  
5 kanskje så er jo ###59:12 så trekker litt farger på huden men den einaste som  
6 ellers så like norske som meg-

Translation:

1 Helen: He's going to adopt- some identity or cultural identity  
2 or ###58:55 so traditions from the country they are born in-  
3 in today- life according to the Norwegian today, the only thing that differentiates  
4 them from- me for example, is that they are maybe- maybe, well they ###59:12  
5 have some colour on their skin but that's the only thing that- otherwise, are  
6 as Norwegian as me.

27/09/13

Time: 58:50

Helen explains she is familiar with immigrants who have successfully assimilated into Norwegian society. The “only” (line 5) thing that distinguishes her from them is they “have some colour on their skin but that’s the only thing that- otherwise, are as Norwegian as me,” (line 5-6). Helen implies assimilation means improving your status through her perspective that besides skin-colour, “they are as Norwegian as me,” having achieved ‘nationalist’ approval from an ethnic Norwegian (civilised vs. savage). However, the

reference to non-white skin-colour as a detractor of 'Norwegianess' suggests Helen is pulling from the interpretive repertoire that Norway is a white space. In addition, Helen ties to the interpretive repertoire that national/cultural membership is restricted to ethnic-Norwegians in that she describes non-white skin-colour as a non-Norwegian visibility marker.

However, Helen simultaneously suggests that adopted children are Norwegian, since she states that besides a non-white skin-colour, "they are as Norwegian as me," (line 6). Helen is suggesting that if ethnic Norwegians adopted a colourblind approach to race, the adopted Norwegians could be considered ethnic Norwegians.

This creates an ideological dilemma between Norway is a white space, national/cultural membership is restricted to ethnic Norwegians and adopted children are Norwegian. Beyond the assumption that 'whiteness' is a crucial ingredient in an ethnic Norwegian, adopted children who are raised in Norway from the earliest stages of memory, potentially share their collective memory with ethnic Norwegians. This potentially connects not to a biological but cultural 'imagined sameness' through the process of cultural assimilation. If the 'non-Norwegians' succeed in this process, they may potentially be accepted as full members to the Norwegian society, which alludes to the interpretive repertoire, national/cultural membership is extended to select 'honorary whites'.

### ***Assimilation means improving your status (1 excerpt)***

This interpretive repertoire suggests that adopting a Norwegian identity implies an improvement in status and assumes a positive transition into a superior culture.

### **Lecture: Professor B**

1 Professor: Integrasjon kan ta ^vare på identiteten din, assimilasjon går du ^opp i et 2 annet folk °sant,?° går opp i et annet °gruppering°.

Translation:

1 Professor: Integration can ^protect your identity, assimilation signifies that you go  
2 ^up in another people, °right?° Going up in another °group°.

06/09/13

Time: 53:00

It is important to establish this is the perspective of the ethnic Norwegian professor, given the position taken. Integration implies protecting one's identity, while assimilation means replacing it. However, the professor implies assimilation is the process of improving one's ethnic and cultural status (civilised vs. savage). The professor appears to be taking the subject position that assimilation is a positive transition as opposed to emphasising the potential loss of cultural identity and heritage. This draws on the interpretive repertoire that 'whiteness' is pure, Norway is a white space and national/cultural identity is restricted to ethnic Norwegians, because 'whiteness' is portrayed as the highest level in the racial hierarchy, and protected by assimilation which represents interest convergence. Assimilation maintains the position of the white race in the hierarchy, while offering non-ethnic Norwegians a potential for 'improved' status (white Europeans are civilised).

### *Assimilation means sacrificing your identity (2 excerpts)*

This interpretive repertoire suggests that assimilation represents a replacement of cultural identity and consequently implies a corresponding loss of cultural roots.

### Lecture: Professor A

1 Professor: Vi har tenkt mentalt, eller psykisk at den kulturen etter oss (2.0) ikke  
2 eksiterer(.)  
3 Sant? Og de resten blitt vernet til norsk ikke sant.  
4 Og det er slikt at kulturell angst altså jeg tror det berører mange i  
5 spesielt I første generasjonene. Kanskje andre generasjonen har ikke den  
6 angsten første generasjonen har i diaspora sant.

Translation:

1 Professor: We have thought mentally, or subconsciously that the culture after us  
2 (2.0) won't exist(.)  
3 Right? And that what's left will be turned into Norwegian, right?

4 And that is how cultural anxiety, I think it affects many especially in the first  
5 generations. Maybe the second generations don't have that anxiety that the  
6 first generations have under diaspora.

30/08/13

Time: 45:25

The non-ethnic Norwegian professor delivers this excerpt. He refers to the realisation of inevitable assimilation as a cultural anxiety. This is something often faced when initial contact is made between two cultures. The perception that people are inescapably pre-determined by their cultural origin ties to cultural essentialism, which gives rise to a colonial mentality. The professor could be taking on the subject position that the sacrificing end of assimilation is a negative experience (assimilation means a loss of identity) through which the white Europeans are categorised as 'civilised' while the 'savage' experiences the cultural anxiety as the 'other' of white Europeans.

### Lecture: Professor A

1 Helen: [Det skal sies at Amerikanere] er veldig flink til å si ja vi er  
2 Amerikanere men med ^en gong dem møter på: noen som er ifra samme  
3 møders, kanskje tipp, tipp oldemora var ifra så ↑Åh! ((Helen claps loudly))  
4 Eg er Norsk!  
5 Ruthie: Uhm  
6 Helen: Jeg jobba I USA og ###42:12 ungan sa "hei du eg er Norsk eg!"  
7 ja ha? Snakker du Norsk da? "nei:"  
8 Er du født I Norge? "Nei."  
9 Er foreldrene dine fra Norge?  
10 "Nei, men jeg har en tip tip oldemor fra Norge"  
11 Men vet du hvor hun var fra I Norge?  
12 °"Nei"°  
13 Class: @@  
14 Men Amerikaneren han er Norsk. Også er det gjerne med Tysk###42:35.  
15 Ruthie: °mhmm°

Translation:

1 Helen: [It is said that Americans] are very good at saying, "yes, we are  
2 American," but the ^moment they meet someone who is from the same  
3 mother- perhaps great, great grandmother was from ↑Oh! ((Helen claps  
4 loudly))  
5 I am Norwegian!  
6 Ruthie: Uhm  
7 Helen: I worked in the USA and ###42:12 the child said, "Hey you, I'm  
8 Norwegian!"  
9 Oh yeah? Do you speak Norwegian? "No."  
10 Are your parents from Norway?

11 “No, but I have a great great grandmother from Norway”  
12 But do you know where in Norway she was from?  
13 °°No”°  
14 Class: @@  
15 But the American, he’s Norwegian. Also surely the German###42:35.  
16 Ruthie: °mhhm°

30/08/13  
Time: 41:00

Helen refers to the average American’s relationship to their nationality as “very good” or that the American level of national sentiment is “very good,” (line 1). Since Helen follows with an observation that American nationality differs from Norwegian nationality, she appears to be suggesting Americans are ‘good at’ national pride as opposed to their national pride being a ‘good’ thing. This is because Helen then says “the moment” Americans encounter someone with a common ancestry that the “great great grandmother was from,” then “I’m Norwegian!” (Line 2-5). This implies being Norwegian involves a national membership that is rooted to the physical space of Norway. The United States on the other hand, is a melting pot where the dominant white population is not considered to have the same level of ownership to the physical geographic space. By saying “The moment” and clapping loudly exclaiming “I’m Norwegian!” suggests Helen is drawing from the interpretive repertoire that national/cultural membership is restricted to ethnic Norwegians, since heritage is being linked to ethnic Norwegians in Norway. Contrarily, Helen appears to suggest Americans are searching for a belongingness to their past ancestry, beyond and before American citizenship. This also infers the majority of Americans do not have a strong or satisfactory connection to their ethnic identity.

However, Helen is curious about what the perception as to what being Norwegian entails. She describes her playful ‘quizzing’ of the ‘self-proclaimed’ Norwegian student from her classroom in America, “oh? Do you speak Norwegian?” “No.” “Were you born in Norway?”



“No.” “Are your parents from Norway?” “No, but my great, great grandmother is from Norway.” “Well, do you know where in Norway she was from?” “No.” (Line 9-13).

This is followed by the class laughing with Helen. These questions imply ethnic Norwegians play the role of a ‘host’ with the accompanying authority and privileges. ‘Norwegianess’ in ‘guests’ is judged from the point of view of an entitled host.

### **5.3 The Racialised ‘Other’**

This category of interpretive repertoires connects examples where racialised groups are specifically identified, their physical characteristics set them apart from ethnic Norwegians. Although substantially smaller than the previous two categories of interpretive repertoires, this third category demonstrates that the concept of racial equality is riddled with ideological dilemmas within the global narrative of white supremacy.

#### ***The Racialised ‘Other’ interpretive repertoires:***

Examples from the transcripts that were identified during data analysis were: Somalis are uneducated - Norway takes better care of children- All black people look alike - Black people have different identities

#### ***African immigrants are uneducated***

This interpretive repertoire implies that African immigrants, specifically Somali people, may be stereotyped and perceived by ethnic Norwegians as uneducated. This indicates an unjustified and condescending generalisation.

#### Colloquia

1 Heidi: Æ skriver bachelor oppgaven min i dette faget no- da tar jeg  
2 også former blant annet em: når vi importere høyt utlands arbediskraft  
3 så tar for meg integrasjonsprosesser til hvilken grad det kreves, forventes  
4 assimilering heller integrering hvilken integreringsprosesser som faktisk  
5 fungerer. Ehm: hvis den som kommer til landet faktisk har en- en for  
6 eksempel tilhørende diaspora då kommer da vedkommende til å  
7 søke opp hovudsakelig- si vedkommende har masse slektninger som  
8 bor i Chinatown i San Francisco. Det er dit vedkommende flytter

9 for-uten jobb-kommer vedkommende til å bare søke seg direkte  
10 dit eller kommer de til å gjøre større innsats for å bli kjent utenfor  
11 aså ja- ###51:47 veldig spennede å se.  
12 Helen: Tenkte du no for dæ det i Norge sånn som Somalere og sånn-  
13 Heidi: [Ja]  
14 Helen: da kanskje låser seg litt i-  
15 Heidi: Nå har æ ikke funnet noen høyt utdannet Somalere som [e på min]  
16 Helen: [@@@]  
17 Heidi: Liste over ehm: over ehm: informanter.

Translation:

1 Heidi: I'm writing my bachelor thesis in this subject now- I will also take on roles  
2 such as em: when we import a highly educated labour force so I'll focus on the  
3 extent integration processes are necessary, whether assimilation or integration is  
4 expected and which integration processes actually function. Ehm: If those who  
5 come to the country actually have a- a for example related diaspora then the  
6 individual will mainly seek- say the individual has lots of family who live in  
7 Chinatown in San Francisco. That is where the individual will move to- without a  
8 job the individual will directly seek their family ties or will they make a greater  
9 effort to become familiar with the outside the uh-yeah ###51:47 very exciting to  
10 see.  
11 Helen: Have you given any thought to Norway in regard to Somali people and  
12 like-  
13 Heidi: [yes]  
14 Helen: maybe there is an isolation-  
15 Heidi: So far I have not found any highly educated Somali people [that are on  
16 my]  
17 Helen: [@@@]  
18 Heidi: List of ehm: of ehm: participants.

27/09/13

Time: 51:50

Heidi describes her bachelor project about the efficiency of the integration processes involved in helping immigrants work in the Norwegian society. Heidi says “very exciting to see,” (line 9) to describe her sentiment toward the project. This sentence describes a curiosity and caring investment toward the immigrants involved. However, Helen follows with “Have you given thought to Norway in regard to Somali people, maybe there is an isolation-,” (line 11-14). Heidi responds, “I have not found any highly educated Somali people...” (line 15) (cultural essentialism). Helen laughs before Heidi finishes her sentence. The laughter suggests Helen draws from the interpretive repertoire that white Europeans are civilised as well as stereotyping the racialised population of Somalis. She is condescending indicated by the assumption that Somali education status is inadequate. Again, the ethnic Norwegian white European ‘we’ are helping the non-Norwegian and racialised ‘them’ (civilised vs. savage).

The assumption that Somali people have limited education is an example of cultural essentialism, where Somali people are perceived as adversely pre-determined by their cultural and geographic origin, while, conversely, ethnic Norwegians are placed at advantage. The emphasis is on the difference between the cultures and a hierarchy is implied.

### *Life in Norway is obviously best*

This interpretive repertoire suggests that in contrast to other cultures, Norway is able to provide a superior quality of life, confirming Norway's role as a generous country.

### Colloquia

1 Heidi: Eg hadde en i klassen en gang som var- var også fra Korea trur æ og-  
2 herlighet- vi spurte alle spørsmålene- han lurte på  
3 litt til å da var- så var ###01:00:15 at e VOX<ja ok her kommer jeg fra et land  
4 kor æ tydeligvis ikke var ønsket og her har jeg blitt tatt vare på og elsket fra  
5 første dag>VOX så ka pokker skulle han med det liksom?

Translation:

1 Heidi: I had one in the class one time who was- was also from Korea I think and my  
2 goodness-we asked all the questions- he wondered a bit on what was- that was  
3 ###01:00:15 that e VOX< Yes, well I come from a country where I was clearly  
4 unwanted and here I've been taken care of and loved from the first day >VOX so  
5 like what the hell is he supposed to do with that?

27/09/13

Time: 01:00:00

Heidi is sharing a story about an adopted Korean peer who, in class, was asked “all the questions.” Heidi uses “we” to describe her and her classmates as unified (imagined sameness). This draws from the interpretive repertoire of Norway is a white space, which would suggest “all the questions” were related to the boy's origin, ethnic background and experience as a ‘non-Norwegian’.

Furthermore, Heidi's story can be interpreted as placing Norway in a parental role; using terms that usually refer to family rather than ‘country’. Heidi continues with the Korean boy's

response, “Yes, well I come from a country where I was clearly unwanted and here I’ve been taken care of and loved from the first day.”

Heidi is explaining the contrast between his previous home and his ‘new’ home in Norway. He feels he was “clearly” not wanted, but “here” he has been cared for and loved from day one (cultural essentialism). This places Norway in a favourable light as the ‘saviour’ role with a parental attitude (civilised vs. savage), which draws on the interpretive repertoires of ethnic Norwegians are moral and non-violent as well as white Europeans are civilised.

At the end, Heidi asks the class “so like what the hell is he supposed to do with that?” referring to his story contrasting his early experience in Korea with his successful assimilation in Norway. The perception suggests assimilation means improving your status, Heidi’s story suggests the boy’s adoption indicated that the transition from Korea to Norway was a positive experience. Heidi appears to be using this example to demonstrate the contrast between Korean and Norwegian treatment of children. This is a typical example of racial stereotyping.

### ***It is impossible to visually differentiate between African ethnicities***

This interpretive repertoire originates from a stereotype that all Africans look alike and act similarly to one another.

#### Lecture: Professor B

1 En liten ting til bare før vi eh: tar pause bare en lit- eh: eh: b-bare et

2 par ord.

3 (4.0)

4 Eg tror det e viktig og å vet at kordan de snakker om de ulike-ulike

5 svarte (.) etniske grupperinger her °sant?,° i sør Afrika↓.

6 (.)

7 Det e viktig å tenke på at de e- de e- okei, kjempe forskjellige °sant,?°.

8 (.)

9 Vi tenker ofte på hvis eg e fra Europa så er jeg (nødt53:33) til å

10 ###53:34 altså det er stor forskjell på nordmenn og spanjoler °sant?,°.

11 (.)

12 °Ikkje så stor forskjell men det er forskjell sant?° det e forskjell på nordmenn og

13 tyskere, °sant,?° ulike språk, ulike kultur.

14 (.)  
 15 Det e stor forskjell på nordmenn og italienere °sant,?°.  
 16 (.)  
 17 Nordmenn og grekere °sant,?°.  
 18 (.)  
 19 Men eg tror det e viktig å ha folk-- klar over at hvis du går til sør Afrika↑ så  
 20 er det stor forskjell på Suluer og Kosaer.  
 21 (.)  
 22 Stor forskjell på ###53:59folk og Kosaer↓.  
 23 (.)  
 24 Sutuene kommer til å ha en ann type identitet enn Suluene vil ha.  
 25 (2.0)  
 26 Helt i nord↑ så har vi eh- eh ###54:11folket °sant,?° som både har igjen  
 27 en helt- en helt ann type eh: type identitet↑ enn folk på: eh:  
 28 i kystområdene ###54:22 i øst Afrika↓.  
 29 (.)  
 30 °Sant?,° vi må tenke på forskjeller her °sant?,° forskjeller på en måte er  
 31 viktig å forstå eh- for å forstå eh: poeng- eh- forstå multikulturalisme↓.  
 32 (1.0)  
 33 Og de store interne forskjeller.  
 34 (.)  
 35 Kanskje hvis vi kommer til:: til Afrika↑ til sør Afrika så ser vi ikkje  
 36 forskjell i det hele tatt på grunn av-- alle ser like ut °sant,?° alle ser like  
 37 ut↓((professor looks at Brit and raises hands innocently)).

Translation:

1 Professor B: One small thing to just before we eh: take a break, just a coupl- eh: eh: j-just a 2 few words.  
 3 (4.0)  
 4 I think it is important to know how they talk about the varying-varying black(.)ethnic  
 5 groups here, °right?,° in South Africa↓.  
 6 (.)  
 7 It is important to consider they are- they are ok, very different °right?,°.  
 8 (.)  
 9 We often think if I am from Europe I (must53:33) to ###53:34 basically there are noticeable  
 10 differences between Norwegians and Spaniards, right? °Not a big difference, but we see a  
 11 difference right?,° there is a difference between Norwegians and Germans right? Different  
 12 languages, different culture.  
 13 (.)  
 14 There are great differences between Norwegians and Italians, °right?,°  
 15 (.)  
 16 Norwegians and Greeks °right?,°  
 17 (.)  
 18 But I think it is important that people-- are aware that if you travel to South Africa↑, there  
 19 are big differences between Zulu and Xhosa.  
 20 (.)  
 21 Big difference between the ###53:59 people and Xhosa↓.  
 22 (.)  
 23 Sotho people will have a different identity than the Zulu people.  
 24 (2.0)  
 25 All the way in the North↑, we have eh- eh- ###54:11 people °right?,° who again have a  
 26 complete- completely different type eh- type: of identity↑ than the people on: eh: the coast  
 27 ###54:22 in East Africa↓.  
 28 (.)  
 29 °Right?,° we have to think about difference here °right?,° differences in a way are  
 30 important 2 to understand eh- to understand eh: eh- understand multiculturalism↓.  
 31 (1.0)  
 32 And the big internal differences.

33 Maybe if we travel to: to Africa↑ to South Africa we won't see  
34 differences at all because-- everyone looks alike °right?,° everyone looks  
35 alike↓((professor looks at Brit and raises hands innocently)).

06/09/13  
Time: 54:38

This is an elementary concept. The professor deemed it necessary to explicitly establish that there is more to an individual's identity than their race, even for black people. The racialised group of Africans have the same cultural variations as white Europeans.

The professor compares the phenotypic and cultural variations of Europeans with the African continent implying there are also distinctive cultural values and national identities in Africa.

“There is a big difference between Norwegians and Spaniards right? We see difference; there is a difference between Norwegians and Germans right? Different languages, different culture,” (line 10-13).

Norwegians and Germans are fairly similar in their physical attributes; yet, there are significant linguistic and cultural differences. These differences challenge the concept of ‘imagined sameness’ by suggesting that visual similarities do not necessarily reflect similar beliefs, behaviour and traditions.

“There are big differences between Norwegians and Italians right? Norwegians and Greeks, right? But I think it is important to make people aware that if you travel to South Africa, then there is a big difference between Zulu and Xhosa,” (line 15-20). Simply because there does not appear to be significant physical difference between people does not mean there are not essential cultural differences. This rejects the ‘colourblindness’ approach to race as African people have different backgrounds and relationships to physical spaces that are not recognised when the population of a continent is treated as the same. Comparing Norwegians with

Germans and then comparing Norwegians with Italians and Greeks suggests a distinction between differences in appearance and differences in cultural identities.

Brit is one of two people of colour in the class. The professor's motion of raising his hands in this circumstance gives the impression 'sorry if this offends you, but it's true'. The professor also uses the word "we" to define who does not see the difference and "everyone" to describe the African population as looking the same. In this context, 'we' is applied toward ethnic Norwegians who make up the majority of the class.

According to the professor, multiculturalism involves significant individual and group differences, even if it might not be as apparent to the class as the contrasts within European nations. Similar to the concept of 'imagined sameness' among ethnic Norwegians, so there is an 'imagined sameness' within individual cultures of the black population on the African continent.

"We must think about differences here, right? Differences, in a way, are important to understand the point of multiculturalism and the large internal differences," (line 30-31). The professor is confronting biological essentialism by implying people are a product of their environment and not determined by their genetic make-up, even if the comparisons are made between people who appear to look the same.

It is worth noting that the professor's use of the words 'svart' [black] and kvit [white] were subsequently recycled by the students. This is in contrast to 'mørkhuda' [darkskinned], 'neger' [Negro] or 'fargede' [coloured], which are the common nomenclatures in the Norwegian media and social discourse.

Lecture: Professor B

1 Professor B: (Utgang54:42) som en: kineser som kommer til Norge °sant,?° som ikkje  
2 greier å se forskjell på nordmenn sant,? Alle nordmenn ser like ut sant,? Så  
3 eh: eh: eg hadde en kinesisk (doktorgradsvenn54:50) som hadde-- tok  
4 et eh: flere måned før han klarte å skille ut eh:: folk i-- i- altså han hadde  
5 et stort problem med at- eh- nordmenn ser kjempe like ut ↑.  
6 (female): °@°  
7 Professor: akkurat som vi- @SM<i Kina så kaller vi kinesere som>SM-- de ser like  
8 ut°sant,?°.  
9 (1.0)  
10 Så når vi-- dersom vi i Afrika-- alle afrikanere ser like ut °sant,?° altså vi greier ikke å se  
11 forskjell på Suluere og Kosaer °sant,?° verken i kroppsspråk eller-  
12 sant,? Hvis vi ik-ikke kan skjønne at de snakker forskjellige språk så blir alle  
13 (til svarte55:17) på en måte.  
14 (.)  
15 Men altså her er det sånt- på samme måte som (.) kvite er ikkje bare kvite  
16 i Europa ↑, men de-det er store forskjeller ###55:26 blant de kvite ↑.  
17 Det er og store forskjeller i ###55:30 blant de svarte i sør Afrika og i  
18 ###55:32 det hele Afrikanske °kontinentet.°  
19 (4.0)  
20 Det er forskjell som går på (.) (svarte språk55:39) det kan gå på ###55:44  
21 det kan gå på livsstil, det kan gå på næringsinntak °sant,?°, det kan gå på  
22 politisk ###55:48 °sant,?°  
23 °Eksetera Eksetera°  
24 (1.0)  
25 (Avhengig55:51) av hva historien har, °sant,?°--  
26 (2.0)  
27 Okei?  
28 (2.0)  
29 Asså (.) det viktig ###56:01 er at eh: det ^insistere og forskjeller sant,? (.)  
30 °sant,?° Så afrikanere er ikkje en-en svart- en svart masse der alle er like  
31 de er kjempe forskjellige ↓ [°grupperinger° ###56:13].

Translation:

1 (Initially54:42) as: a Chinese person coming to Norway °right?,° that can't distinguish  
2 between Norwegians °right?,° All Norwegians look alike, right?, so I had a eh- eh- Chinese  
3 (doctorate friend54:50) who had-- took several months before he was able to differentiate  
4 eh:: people in-- in- basically he had a big problem with that- Norwegians look very  
5 similar ↑.  
6 (female): °@°  
7 Professor: Just like we- @SM<in China we call Chinese>SM-- they look the same °right?,°.  
8 (1.0)  
9 So when we-- when we look at Africa-- All Africans look the same °right?,°.  
10 Basically, we can't see the difference between Zulu and Xhosa °right?,° neither in  
11 body language, nor- right? If we ca-can't tell they speak different languages °right?,° they  
12 (become black55:17) in a way.  
13 (.)  
14 So basically here- in the same way that (.) whites are not just whites in Europe ↑, but they  
15 are- have big differences ###55:26 among the whites ↑.  
16 There are big differences among ###55:30 among the blacks in South Africa and in  
17 ###55:32 all of the African °continent°.  
18 (4.0)  
19 The focus is on difference (.) (black language55:39) it can involve ###55:44 it can involve  
20 lifestyle, it can involve nutrition °right,° it can involve political ###55:48 °right,°  
21 Etcetera Etcetera  
22 (1.0)  
23 Depending on what history has, °right?,°



24 (2.0)  
25 Ok?  
26 (2.0)  
27 Basically (.) What is important ###56:01 is that eh: it ^insists also differences right?, (.)  
28 °right?° So Africans are not a-a black- a black mass where everyone is identical,  
29 they are very different↓ [°groupings° ###56:13]

06/09/13  
Time: 56:00

The professor is encouraging the students to see that once a racial category is applied to a group, the opportunity to differentiate individuals becomes lost, identified primarily by their racial category and classified as the ‘other.’ In lines 1-5, the professor is comparing an ethnic Norwegian’s difficulty of distinguishing Africans with a Chinese person’s struggle with differentiating between ethnic Norwegians. “Just like we- @SM<in China we call Chinese>SM-- they look the same °right?,”(Line 7).

The difference here is although the professor draws from the interpretive repertoire that Norway is a white space when he mentions that “All Norwegians look alike” (line 2) (imagined sameness), the professor also indicates ethnic Norwegians are different from one another by highlighting that his Chinese friend began to distinguish between Norwegians after a few months. The professor’s claim that over time, foreigners may gradually begin to distinguish between ethnic Norwegians implies an ideological dilemma in that the concept of imagined sameness does not apply equally to both ethnic Norwegians and black Africans.

“All Africans look the same °right?°. Basically, we can’t see the difference between Zulu and Xhosa °right?°, neither in body language, nor- right? If we ca-can’t tell they speak different languages °right?°, they (become black55:17) in a way” (lines 9-12) (biological essentialism). If one doesn’t hear differences in the varying tribal languages, it is unlikely ethnic Norwegians will be able to perceive a difference between the tribesmen. This risks

uncritically grouping the African continent into a unified identity that does not extend beyond the colour of their skin. The professor is stating without understanding the tribal languages, that there is no way to distinguish between the Africans. However, this contrasts with the professor's perspective on ethnic Norwegians, given that after a few months, his Chinese friend was able to visually distinguish between them.

“...whites are not just whites in Europe↑, but they are- have big differences ###55:26 among the whites↑. There are big differences among ###55:30 among the blacks in South Africa and in ###55:32 all of the African °continent°,” (Lines 14-17). Like white Europeans, black Africans are not limited to a one-dimensional identity. This challenges the notion of the civilised vs. the savage by emphasising that the idea of culture and nations having their own unique characteristics and values are not restricted to Western civilisations.

This idea is continued, “...So Africans are not a-a black- a black mass where everyone is identical, they are very different↓ [°groupings° ###56:13],” (line 28-29). The rejection of a ‘black mass’ implies that the professor is attempting to debunk the Europeanised concept of ‘imagined sameness’ which has been applied across the African continent, and is instead insisting that cultural essentialism limits the perception of individual identity. Notice how the ethnic Norwegian professor cut the sentence short when he said, “Basically, we can’t see the difference between Zulu and Xhosa °right?°, neither in body language, nor- right?” This exemplifies how the message is implicitly conveyed without actually saying the words and risking accountability for the potential use of an explicit racial term.

## 6. Discussion

This research project prospectively defined several objectives related to the use of discourse analysis to describe and interpret spontaneous interaction and discussion concerning racial issues in an academic Norwegian classroom environment. This discussion will examine the findings in the context of the theoretical framework.

The primary objective of this study was to understand how the concepts of race and racialisation are expressed in Norwegian classroom discourse in a university environment.

The technique of discourse analysis and the development of interpretive repertoires were used to identify categories of comments that revealed common views and concepts related to Norwegian attitudes towards racial issues. In addition, a secondary objective was included to compare expert-based knowledge (lectures) and interactive-based knowledge (colloquia) in classroom discourse.

Although the data collected with regard to classroom discourse in the four transcriptions was sufficient to evaluate the primary objective, comparison between lectures and colloquia proved to be more challenging. There were only two professors: one ethnic Norwegian and one non-ethnic Norwegian. By the nature of the format, the amount of interactive discussion between the participants in the lectures was very limited.

### **6.1 Interpreting the findings in terms of the theoretical framework**

The theoretical framework provided a lens, which identified overlapping and recurrent themes that pervaded the classroom discourse. The application of discourse analysis and interpretive repertoires provided a number of specific examples that describe the language used by Norwegians engaged in racial discourse.

Critical Race Theory provided a useful tool for identifying and understanding relevant excerpts in the transcriptions. For example, a recurrent theme in Norwegian classroom discourse is an aspiration to colourblindness as an anti-racist approach. Several culture-specific values, such as ‘imagined sameness’ [likhet], contribute to a setting that has potentially led to a systematic disadvantaging of non-whites, through interest convergence, which prioritises the protection and perpetuation of the status quo over social change. Full membership in a society is a requirement if an individual is to “realise aspirations, to satisfy needs, and to change or cope with the environment,” (WHO, 1986).

The main findings reported in this thesis confirm the essential importance of Norwegian ethnicity in defining Norwegian identity. At least equally important in defining identity are the physical characteristics typical of an ethnic Norwegian appearance. Specifically, ‘whiteness’ appears to be an explicitly required criterion for being accepted by ethnic Norwegians as Norwegian. The findings suggest a strong correlation between biological factors (race/skin-colour) and national/cultural belonging. An explicit example from the findings emerged when Helen explained: “well they ###59:12 have some colour on their skin but that’s the only thing that- otherwise, are as Norwegian as me.” This quote indicates that not being white has the potential to detract from Norwegian national/cultural belonging. This helps explain the common question “where are you from?” because non-white skin tones emphasise a foreign origin. In another example, Tone, the colloquia leader, describes the sentiment of national/cultural belonging being race-related, “Shall we say that it greatly depends on the race right? Or- (Qualitative59:34) is very possible- they feel like strangers for example in the Norwegian society because they become- they look different but they are actually Norwegian so- it greatly depends on ethnic belonging ###59:45.”

Biological vs. cultural essentialism assists in identifying two competing concepts. The findings clearly indicate both biological phenotype and geo-cultural origin are determining factors in establishing identity and belonging.

Encouraging a colourblind approach in a society where white privilege is a birth right in the great majority of the population is convenient and, therefore, represents an ideological dilemma. Although the motivation supporting a colourblind approach may be altruistic, the effect may be the opposite in that inequalities perpetuating racial discrimination and marginalisation of the racialised population may not be recognised and addressed.

## **6.2 How racial issues are discussed in classroom discourse**

Although there was discussion about issues related directly and indirectly to race and ethnicity, the racial discourse itself was elusive and challenging to categorise. Indirect references and symbolic nuances are the root of the Norwegian classroom racial discourse. Interpretive repertoires under the broad categories of ‘whiteness’ and ‘ethnic Norwegian’ were frequently drawn from the classroom discourse and indicate the strength of the focus on protection of Norway with its values and traditions from the threat of emerging globalisation and multiculturalism.

Ethnic origins are explicitly discussed, but the only racial term used in the two lectures and colloquia was ‘svart’ [black], ‘kvit/hvit’ [white]. Importantly, there is no consensus on what the appropriate and respectful racial terminology should be. For example, the common terms ‘mørkhuda’ [darkskinned] ‘neger’ [Negro] or ‘fargede’ [coloured] were never used in any of the interactive classroom discourse. However, the ethnic Norwegian professor’s use of ‘svart’ and ‘kvit’ appeared to have influenced the students’ choice of words, because they repeated

those terms in that lecture but not in the other lecture or colloquia. An example of avoidance of the use of explicit racial terminology occurred when participants alluding to ‘white’ as “they look like me/us” or non-whites as “they don’t like me/us” in the colloquia, where the professors were not present to legitimise the terms.

Although racial discourse avoided specifics, ethnicity appeared to dominate and replace or disguise race in the classroom discourse. The importance of ethnic origin was frequently emphasised and appeared to be an essential component defining national belonging. For example, in the discourse analysis, the term ‘ethnic Norwegian’ was allocated to white Norwegians and racialised children adopted at birth, with no prior exposure to foreign culture. One of the participants of colour stated that an immigrant could achieve the status of a ‘true’ Norwegian ie. ‘honorary white’ if they make an important and recognised contribution to the society or country, specifically referring to immigrants talented in sports. These exceptions to the concept of eligibility to white privilege and the interpretive repertoire of Norway as a white space represent an ideological dilemma in which society requires extraordinary achievement in order to attain honorary white status. This attitude may serve to preserve Norwegian identity as ‘pure’ and could be seen to represent interest convergence. However, traditionally, Norwegian ethnicity assumes the white race, as Ruthie says, “they look different but they are actually Norwegian.” These issues relate directly to the central concepts of race, identity and exclusion.

Ethnic Norwegians may consider themselves hosts in Norway due to their birth right to national ownership. Immigrants might potentially feel like guests even with Norwegian citizenship. For example, the non-ethnic Norwegian professor described an encounter that occurs frequently in which a racialised Norwegian is told “but you don’t look Norwegian.”

This not uncommon experience may marginalise racialised, non-ethnic Norwegians and can weaken their sense of belonging.

In the classroom discourse, ideological dilemmas frequently emerged regarding perceptions concerning adoption and ethnicity. “They are aware that they are from Korea...but they are ethnic Norwegians first and foremost.” Ethnic Norwegians could be seen as adopting a parental attitude toward non-Norwegian immigrants residing in Norway, “I have: very many from China who are adopted. Right now, I live with one who was adopted from Colombia.” A parental attitude is not necessarily patronising, but does assume an authoritative position.

The concept of the interpretive repertoire Norway is a white space frequently provides insight into the recurring theme that ethnic Norwegian identity is tied to its physical space.

Norwegians may appear to perceive Norwegian geography and the physical space as an essential part of defining national identity in Norway. There is a symbiotic relationship here with the presence of an ethnic Norwegian majority preserving its international image as a pristine and peaceful country. As Helen’s anecdote about the American student exemplifies, “are your parents from Norway?” “No, but I have a great, great grandmother from Norway.” As the comparison highlights, Norwegians consider that they share a common heritage with the physical environment. This contrasts with an American identity, which does not share the same dependence on the physical space. The American sees himself as ethnic Norwegian due to his roots. However, the Norwegian does not agree that this alone makes the American eligible to be considered Norwegian.

A host vs. guest attitude was observed where the ‘us’ and ‘we’ clearly refer to the dominant ethnic Norwegian group, which possess the majority of cultural and political power. The

racial discourse appeared to reflect the position and views of the majority, with a well defined discursive divide between ‘us vs. them’ along the lines of ethnic Norwegians and the ‘other’ living in Norway. The professor’s example, “Even when you have lived here quite long, right?, still, they ask you where you come from, right?,” implies that no matter how long a racialised individual lives in Norway, they will be treated like a guest.

### **6.3 Racial discourse in the two different learning settings: Lectures and Colloquia**

The formats of the lecture-based (expert knowledge) and the colloquia (constructed knowledge) represented two very different approaches and the nature of the racial discourse differed both in quantity and diversity. The two professors in lecture-based settings spent the majority of the class time lecturing, so there was considerably less student participation. When the students did participate, they generally directed their comments and questions toward the professor limiting interactive discussion with their fellow classmates. In contrast, there was substantial class interaction in the colloquia. The colloquia differed from the lectures in that the same leader, Tone, had responsibility for both colloquia. The colloquia setting was, therefore, far more conducive to free expression. Tone saw her role as facilitating exchange between the students, where the authoritative position of the professors appeared to inhibit the flow of discussion.

### **6.4 Expert vs. interactive learning based environments**

Importantly, the colloquia followed the lectures and the course material presented in the lectures was subsequently discussed in the colloquia. Therefore, the lectures guided the subject matter in the colloquia. The students had been introduced to the issues through the lectures and their readings. The racial discourse was therefore influenced both by the prior exposure to the topic and the terminology provided by the professors. For example, ‘diaspora’ was a recurring theme in the colloquia in that it was a fundamental concept in the lectures.



In the lecture setting, the students appeared to employ practically identical racial terminology as the professor. This suggests the students followed the professor's lead regarding the 'proper' terms for describing varying races and discussing racial issues. The terminology employed in the expert-based knowledge setting influenced the development of the interactive-based knowledge. The ethnic Norwegian professor frequently opted for English racial terminology such as "coloured" and "mixed marriages." This indicates a relatively underdeveloped Norwegian racial terminology as compared with English.

In colloquia, the students would sometimes pause or cut the sentence short rather than use a specific racial or ethnic term, indicating an uncertainty or reluctance to risk choosing a potentially insensitive or derogatory term. To convey that the message was implicitly understood and verbalising the explicit racial or ethnic term was unnecessary, the humming of other students in agreement sometimes followed or interrupted a sentence progression. Humming in agreement or "Mhmm" was observed frequently in the colloquia indicating agreement between the participants in an interactive learning environment, but not used once in either lecture. However, in the lectures, a similar discursive pattern emerged when the ethnic Norwegian professor cut the sentence short when describing the similarities and differences between Zulu and Xhosa, he pauses and avoids explicit terms, "neither in body language, nor- right?"

There were few disagreements among the participants in the colloquia. The abrupt and short words such as, "ja" [yes] "nettopp" [exactly] and "mhmm" [humming in agreement] implies that the participants utilised these words to demonstrate solidarity and support among one

another while talking about uncomfortable and potentially taboo issues without the presence of expert knowledge.

A position of authority and privilege can shape the perspective of a social reality. The ethnic Norwegian professor took the position of the interpretive repertoire that assimilation meant 'going up' or improving your status. In contrast, the non-ethnic Norwegian professor drew from the interpretive repertoire that assimilation means losing your identity. Here the ethnic Norwegian professor positions himself within the privileged race and the racial hierarchy is tacitly assumed. The non-ethnic Norwegian professor describes assimilation as 'cultural anxiety' emphasising the loss of cultural heritage rather than the gain in status. This interpretation places focus on the issues related to identity and the sacrifices that assimilation entails. Without a critical perspective concerning white privilege, a white person may risk confirmation bias clouding their judgement for a justification for one's position within their racial hierarchy.

### **6.5 The impact of racism in Norway**

Racism, intentional or unintentional, creates a negative and restrictive influence on the well-being of minority groups, while placing those at the top of the racial hierarchy at advantage. Both the entitled population and the marginalised groups become victims of a distorted reality perpetuating the concept of racism in modern society, which prevents individuals from "realising aspirations" as outlined in the Ottawa Charter. Efforts to recognise the origins of racist perceptions and improve race relations qualify as strategic health promotion measures. This thesis employs discourse analysis from university classroom settings as a tool to potentially better understand how Norwegians, in an increasingly multicultural environment, may communicate and develop their opinions related to racial issues.

Racism serves to establish and maintain an unequal power balance and unequal access to resources between members of a society. Therefore, the impact of racism in a society represents an important obstacle to achieving effective health promotion. Institutional racism requires institutional power and “depends on the ability to give or withhold social benefits, facilities, services, opportunities etc., from someone who should be entitled to them, and are denied on the basis of race, colour or national origin,” (SASC, 2013). A common example of institutional racism is a hierarchy based on the creation of a racial identity termed ‘whiteness’ that was used as a strategy by the elite in European empires to distinguish themselves as dominant and privileged.

The Norwegian context of race relates to the historical expansion of European imperialism. This colonial era created the conditions that permitted the legitimate practice of white-favouring institutional racism, which resulted in subsequent extensive racial subordination (Winant, 2000). From the 16<sup>th</sup> century through the mid 20<sup>th</sup> century, colonial Europe had a central role in the global dissemination of white superiority. This institutional racism was applied through the expansion of colonial territory and the replacement of local laws and tradition with the establishment of European rule. Implementing foreign rule exploited the non-European native populations and placed them at a disadvantage through self-serving education, religious practice and governing law (Singh, 2007).

The success of the transformation from a homogenous to a heterogeneous population might be hampered by fundamental, xenophobic cultural values that discourage the Norwegian community from associating with people who appear ‘different’. Gullestad theorised that the concept of ‘imagined sameness’ evolved in order to promote standard behaviour in Norwegian society. Yet, in a rapidly changing multicultural society such as Norway, these

unifying cultural values place racialised and immigrant Norwegians at risk of being excluded from active participation in Norwegian culture. This serves to ultimately prevent non- ethnic Norwegians from achieving the privileges and cultural benefits of accessing ownership of their Norwegian citizenship (Gullestad, 2002).

In Norway, it is challenging to refer to race and racialisation in polite conversation without the risk of being viewed as xenophobic or racist, “For a long time Norway has not known how to deal with its immigrants and especially African communities because we fear being called racists,” (Awuonda, 1996). This quote describes an important Norwegian cultural perception that discourages public expression of controversial personal opinion. There is an inherent challenge in recognising a seemingly unconscious exclusion of the ‘other’ in a country where there exists an underdeveloped discourse for expressing candid opinions concerning race in Norway (Wikan, 1999).

It has been proposed that Norwegian racial discourse is coded by characteristic and symbolic language. There is frequently limited effort to make distinctions between individuals with various backgrounds creating a stereotype of the ‘foreigner’. This gives rise to an ‘us vs. them’ host and guest nationalist positioning that devalues the sovereignty of foreign cultures (Gullestad, 2006). In this way, ethnic Norwegians may ascribe to a ‘colourblind’ approach in which the solution to racial prejudice and racial inequality is to not ‘see’ race. A ‘colourblind’ approach to race is a perspective that views racist acts as deviant behaviours in an otherwise benevolent society. The possibly destructive nature of this perspective is that it serves to dismiss racist acts as isolated events rather than the result of an institutional indoctrination of racial bias observed at the individual level (Hübinette, Hörnfeldt, Farahani & Rosales, 2012).

“#Norskrasisme” is a Norwegian twitter movement initiated by Warsan Ismail to combat the concept that racism is either ‘dead’ or an isolated experience, “Noen Twitter-brukere benyttet hashtagen til å lenke til artikler i norske medier. Andre fortalte om rasismen de møter på buss, gate og jobb,” [Some twitter users linked the hashtag to related articles in Norwegian media outlets. Others shared their experiences with racism on the bus, street and at work,] (Selmer-Anderssen, 2013).

In response to Norway’s seemingly increasing awareness of racism in a multicultural society, popular television programmes emerge such as Lilyhammer, Norsk Nok? [Norwegian Enough?] and Alt For Norge [All For Norway]. These programmes accentuate and explore Norwegian nationalism, cultural exclusion and racism by means of satire, reality television and documentary format, which may serve to reinforce pervasive racial stereotypes. Some of the storylines appear blatantly racist; Lilyhammer, which airs on the Norwegian state-owned television station NRK, often draws on racial stereotyping such as the sexual objectification of black people, a close relationship between people of colour, drug use and criminal activity as well as the corruption of innocent and naive ethnic Norwegians by foreign influence.

Like adopted children young enough to not have any recollection of a previous culture before moving to Norway, immigrants are also expected to assimilate into the Norwegian culture and leave their previous identity behind in the process. This is not an attitude founded in mutual respect and can understandably de-motivate immigrants from embracing and integrating into a new society.

An increased understanding of the impact of specific aspects and nuances of racial discourse could promote public dialogue, which may potentially place focus on how issues relating to

race and racialisation are approached in Norwegian society. Interpretation of the data collected on racial discourse in the two university classroom settings has the potential to increase understanding of the true extent of the impact of racism in Norway, while also placing focus on the limited awareness of this topical humanitarian issue.

## **6.6 Limitations**

In order to assess the validity of the findings it is essential to identify potential limitations related to the design of the research, the collection of the data and interpretation of the findings. Three categories of limitations were identified relating to subject matter, methodology and interpretation.

### **Subject matter**

The subject matter in this study is sensitive. Discourse in Norwegian classroom environments related to race and racialisation is by its nature challenging to analyse in that views are often expressed indirectly, evasively and cautiously. Opinions were varied, fluid and context-dependent. In order to adequately explore the true scope of racial discourse in Norwegian classrooms, a more extensive investigation in various academic environments at several Norwegian universities would be required. Similarly, increasing the number of transcribed classes would potentially identify a broader selection of interpretive repertoires.

### **Methodology**

The sample population for the project was small with an average of 12 participants in each of the four sessions of the course (approx. half of students did not attend classes). The gender ratio in the course was uneven, with few males in each of the two lectures and two colloquia. Females dominated the discussions. The only two students of colour were female. This limits the representativeness and intersectionality of the views expressed. Comparison of the racial discourse between expert-based knowledge settings and constructed-knowledge settings is only based on two professors; one ethnic Norwegian professor and one non-ethnic Norwegian

professor. It is not possible to make comparisons between the guidance of the constructed-based knowledge because the same colloquia leader led both meetings.

Several aspects of the methodological approach created challenges in collecting and analysing classroom discourse data. The findings are presented in English, but only after being analysed from Norwegian transcripts and then being translated. Phrases, dialects and nuances might have been lost in translation. The researcher was raised in Stavanger, a neighbouring city to Bergen. Although the cities are near each other, the differing dialects in the two cities were readily noticeable. Therefore, it may be expected that some nuances based on dialect and linguistic or symbolic conveyance might not have been detected. Significant words were frequently inaudible in the recordings due to heightened physical activity in the discussions such as clapping, tapping feet, laughing or interrupting the speaker. These unidentified words have an unknown effect on the interpreted message. Although there was a training period prior to data collection, this was the researcher's first experience with coding transcriptions. Although data collection took place in a traditional classroom environment, the researcher and microphones were frequently in clear view, potentially inhibiting the natural flow of discussion considering the small group of students present for each lecture and colloquium (see Fig.1).

### **Interpretation**

Discourse analysis is an inherently subjective tool. The researcher's perspectives influence both the identification of racial discourse in the transcripts and the subsequent identification of interpretive repertoires. The researcher has dual citizenship and experience from both multicultural environments and Norway, creating potential bias. The findings of this thesis should be interpreted with appropriate conservatism.

## 7. Conclusion

Several broad conclusions emerge from the findings of this discourse analysis in Norwegian classroom settings. Ethnic origin and ‘whiteness’ appear to represent essential concepts to ethnic Norwegians. ‘Whiteness’ is an essential criterion to be considered a ‘true’ ethnic Norwegian. There appears to be a close interplay between biological factors (race/skin-colour) and Norwegian national/cultural belonging. Interpretive repertoires such as ‘whiteness’ and ‘ethnic Norwegian’ are broad categories grouping many of the comments from the classroom discourse. White privilege sets the stage for a host vs. guest attitude where the ‘us’ and ‘we’ may reflect the ethnic Norwegian’s view of Norway as a white space. A recurring theme was a parental attitude towards non-Norwegian immigrants residing in Norway. There is a well-defined discursive distinction between ‘us vs. them’, which separate ethnic Norwegians from the ‘other’ living in Norway. Ethnic Norwegians are traditionally nationalists and much of the focus of the discussion of racial issues is related to the recent and rapid transition into a multicultural nation.

The discourse that focused on race and racialisation was frequently cautious, evasive and challenging to interpret. The findings suggest the participants were more comfortable discussing ethnicity than race. The Norwegian terminology used to discuss racial issues is apparently underdeveloped and this may serve to inhibit explicit racial discourse. Effective dialogue that accurately expresses one’s views is an essential tool leading to empowerment and the path to understanding, thereby supporting the pillar of health promotion.

“It is not our differences that divide us, it is our inability to accept and celebrate those differences,” Audre Lorde



## 8. References

- AIMCA. (2010). Loughborough Diaries 2: Jonathan Potter [video file]. Retrieved 2013, April 10, from <https://www.youtube.com/watch?v=I4wJyFumjn8>
- Albrecht, T. L., Foster, T. S., Franks, M. M., Orom, H., Penner, L. A., & Ruckdeschel, J. C. (2007). Camera-related behaviors during video recorded medical interactions. *Journal Of Non-verbal Behaviour*, 31(2), 99-117. doi: 10.1007/s10919-007-0024-8.
- Alsvik, S., Aurvåg, T. F., Gamlem, L. M., Hopland, G. H., Ottesen, M. S., Van, Z. S., & Flatiron Film Company. (2011). *Lilyhammer: Season one*. London: BBC4
- Anghie, A. (1996). Francisco de Vitoria and the Colonial Origins of International Law. *Social & Legal Studies*, 5(3), 321–336.
- Awuonda, M. (1996). Norway's racism row simmers on. *The Lancet*, 348(9025), 468.
- Bakkerud, A., Moan, A., & Molteberg, K. (2007). *Livsløp og Velferd* (3rd ed.). Cappelen.
- Beck, A. J., & Bonczar, T. P. (1997). Lifetime likelihood of going to state or federal prison. *Birth*, 5(4.4), 28-5. Retrieved 2014, May 28, from <http://www.bjs.gov/content/pub/pdf/Llgsfp.pdf>
- Bennett, S., Woods, T., Liyanage, W. M., & Smith, D. L. (1991). A simplified general method for cluster-sample surveys of health in developing countries. *World Health Statistics Quarterly. Rapport trimestriel de statistiques sanitaires mondiales*, 44(3), 98-106.
- Behrendt, S. D., & Rawley, J. A. (2005). *The transatlantic slave trade: a history*. Lincoln. University of Nebraska Press.
- Berg, A. J. (2008). Silence and Articulation: Whiteness, Racialization and Feminist Memory Work. *Nordic Journal of Feminist and Gender Research*, 16(4), 213-227.
- Bhopal, R. (2004). Glossary of terms relating to ethnicity and race: for reflection and debate. *Journal of epidemiology and community health*, 58(6), 441-445.
- Billig, M., Condor, S., Edwards, D., Gane, M., Middleton, D. Radley, A.R. (1988) *Ideological Dilemmas: A social psychology of everyday thinking*. London: Sage Publications.
- Bowker, G. C., & Star, S. L. (2000). Sorting things out: Classification and its consequences. *Inside Technology*. MIT University press.
- Brah, A. (1991). Difference, diversity, differentiation. *International Review of Sociology*, 2(2), 53-71. doi: 10.1080/03906701.1991.9971087
- Brochmann, G. (2008). Immigration, the Welfare State and Working Life—the Case of Norway. *European Review*, 16(04), 529-536.

- Brophy, A. L. (2008). Plessy v. Ferguson, 163 U.S. 537 (1896). In D. S. Tanenhaus (Ed.), *Encyclopedia of the Supreme Court of the United States* (Vol. 4, pp. 52-56). Detroit: Macmillan Reference USA.
- Bygnes, S. (2012). Gender-equality as boundary: 'Gender–nation frames' in Norwegian EU campaign organizations. *European Journal of Women's Studies*, 19(1), 7-22.
- CAMH. (2012). Break Down Barriers: Think about the effects of racism and discrimination. Chapter 1. Retrieved 2013, January 21, from [http://www.camh.ca/en/hospital/about\\_camh/health\\_promotion/culture\\_counts/Pages/culture\\_counts\\_chap1\\_racism.aspx](http://www.camh.ca/en/hospital/about_camh/health_promotion/culture_counts/Pages/culture_counts_chap1_racism.aspx)
- Crenshaw, K. (1991). Mapping the Margins : Intersectionality , Identity Politics , and Violence Against Women of Color. *Stanford Law Review*, 43, 1241–1299.
- Delgado, R., & Stefancic, J. (2011). *Critical race theory: An introduction*. Seattle University School of Law Research Paper. New York University Press.
- Durpaire, F., & Mabilon-Bonfils, B. (2013). De l'éducation nationale à l'école cosmopolitique. *Tréma*, (40), 102-113.
- Døving, C. (2014, 25. February). Rasisme på norsk. Dagbladet. Retrieved 2014, September 9, from <http://www.dagbladet.no/2014/02/25/kultur/meninger/hovedkronikk/rasisme/kronikk/32013896/>
- Edley, N. (2001). Analysing masculinity: Interpretative repertoires, ideological dilemmas and subject positions. *Discourse as data: A guide for analysis*, 189-228. Press SAGE.
- Ereshefsky, M. (2010). What's wrong with the new biological essentialism. *Philosophy of Science*, 77(5), 674-685.
- Falola, T., & Roberts, K. D. (2008). *The Atlantic World: 1450-2000*. Bloomington: Indiana University Press. doi: 10.1080/03086530903157730
- Fischer, M. M., & Marcus, G. E. (1999). *Anthropology as cultural critique: An experimental moment in the human sciences*. (2) University of Chicago Press.
- Forman, T. (2001). Social determinants of White youths' racial attitudes. *Sociological Studies of Children and Youth*, 8, 173–207.
- Gilman, S. L. (1985). Black bodies, white bodies: Toward an iconography of female sexuality in late nineteenth-century art, medicine, and literature. *Critical Inquiry*, 204-242.
- Grillo, R. D. (2003). Cultural Essentialism and Cultural Anxiety. *Anthropological Theory*, 3(2), 157-173.

- Gullestad, M. (2002). Invisible fences: egalitarianism, nationalism and racism. *Journal of the Royal Anthropological Institute*, 8(1), 45-63.
- Gullestad, M. (2005). Normalising racial boundaries. The Norwegian dispute about the term neger1. *Social Anthropology*, 13(1), 27-46.
- Gullestad, M. (2006). *Plausible prejudice: everyday practices and social images of nation, culture and race*. Oslo: Universitetsforlaget.
- Hagelund, A. (2002). Problematizing culture: Discourses on integration in Norway. *Journal of International Migration and Integration/Revue de l'integration et de la migration internationale*, 3(3-4), 401-415.
- Haggis, J. (2004). Thoughts on a politics of whiteness in a (never quite post) colonial country: Abolitionism, essentialism and incommensurability. *Whitening Race: Essays in social and cultural criticism*, (1), 48. Aboriginal Studies Press.
- Harris, C. I. (1993). Whiteness as Property. *Harvard Law Review*, 106(8), 1707–1791.
- Hernes, G., & Knudsen, K. (1990). Svart på hvitt: norske reaksjoner på flyktninger, asylsøkere og innvandrere. Fagbevegelsens senter for forskning, utredning og dokumentasjon. *FAFO rapport 109*. Oslo: FAFO
- Hübinette, T., Hörnfeldt, H., Farahani, F., & Rosales, R. L. (2012). *Om ras och vithet i ett samtida Sverige*. Stockholm: Mångkulturellt Centrum.
- Kubota, R. (2001). Discursive construction of the images of US classrooms. *TESOL Quarterly*, 35(1), 9-38.
- Le Couteur, A., & Augoustinos, M. (2001). The language of prejudice and racism. In M. Augoustinos & K. J. Reynolds (Eds.), *Understanding prejudice, racism and social conflict* (pp. 215-230). Thousand Oaks, CA: Sage Publications.
- Lie, E. (2002). Numbering the nationalities: ethnic minorities in Norwegian population censuses 1845-1930. *Ethnic and racial studies*, 25(5), 802-822.
- Lillebo, M. (2008, 14. May) Norske jenter har seg selv å takke. P4. Retrieved 2014, August 14, from <http://www.p4.no/story.aspx?id=272134>
- Lewis, A. E. (2001). There Is No “Race” in the Schoolyard: Color-Blind Ideology in an (Almost) All-White School. *American Educational Research Journal*, 38(4), 781–811. doi:10.3102/00028312038004781.
- Mahmud, T. (1997). International Law and the “Race-ed” Colonial Encounters. Proceedings of the Annual Meeting. *American Society of International Law*, 91, 414–420.
- Marjomaa, M., (2012). North Sámi in Norway: An Overview of a Language in Context. *Working Papers in European Language Diversity*. Retrieved 2013, January 15, from [http://www.oulu.fi/sites/default/files/content/Giellagas\\_Marjomaa\\_NorthSamiInNorway.pdf](http://www.oulu.fi/sites/default/files/content/Giellagas_Marjomaa_NorthSamiInNorway.pdf)

- Molstad, K. (2011, 15. October). Innvandrere bak alle anmeldte overfallsvoldtekter i Oslo. Aftenposten. Retrieved 2014, September 3, from <http://www.aftenposten.no/nyheter/iriks/-Innvandrere-bak-alle-anmeldte-overfallsvoldtekter-i-Oslo-5569378.html>
- Möschel, M. (2011). Race in mainland European legal analysis: towards a European critical race theory. *Ethnic and Racial Studies*, 34(10), 1648–1664. doi:10.1080/01419870.2011.566623.
- Nutbeam, D. (1998). Health promotion glossary1. *Health promotion international*, 13(4). Retrieved 2013, March 9, from <http://heapro.oxfordjournals.org/content/13/4/349.full.pdf>
- Phelps, J. M., Blakar, R. M., Carlquist, E., Nafstad, H. E., & Rand-Hendriksen, K. (2012). Symbolic boundaries and ideology in the Norwegian multicultural society: A longitudinal study of public discourse. *Journal of Community & Applied Social Psychology*, 22(3), 187–205.
- Phillips, S. (1999) ‘The convergence of the Critical Race Theory workshop with LatCrit theory: a history’, *University of Miami Law Review*, vol. 53, pp. 1247-472.
- Potter, J., & Wetherell, M. (1987). *Discourse and social psychology: Beyond attitudes and behaviour*. Sage.
- Potter, J. (1996). Discourse analysis and constructionist approaches: Theoretical background. *British Psychological Society*. Retrieved 2013, December 9, from <https://dspace.lboro.ac.uk/dspace-jspui/bitstream/2134/9487/7/Richardson%20Handbook%20Chapter.pdf>
- Razack, S. H. (2004). Imperilled Muslim Women, Dangerous Muslim Men and Civilised Europeans: Legal and Social Responses to Forced Marriages. *Feminist Legal Studies*, 12(2), 129–174.
- Riggins, S. H. E. (1997). The language and politics of exclusion: Others in discourse. *Communication and human values*. Sage.
- Rogstad, J. (2013). Racism Concept Gets Hands Off In Norway: Norwegians are too politically correct to use the term racism and prefer to shy away instead, an academic believes. Retrieved 2013, April 19, from <http://m.theforeigner.no/pages/news/racism-concept-gets-hands-off-in-norway/>
- Sandemose, A. (1933). En flyktning krysser sitt spor: fortelling om en morders barndom (Vol. 28). Gyldendal. Retrieved 2013, March 2, from <http://www.janteloven.no/>
- SASC. (2013). *Gender Accountability Statement*. Retrieved 2014, January 19, from <http://www.sascottawa.com/en-US/Content/Detail/120.aspx>
- Selmer-Anderssen, P. (2013, November 20). Dette er meldingen som startet Twitter-debatten om norsk rasisme. Retrieved 2014, February 6, from <http://beta.mobil.aftenposten.no/nyheter/iriks/Dette-er-meldingen-som-startet-Twitter-debatten-om-norsk-rasisme-7376406.html>

- Seale, C., Silverman, D. (1997) 'Ensuring rigour in qualitative research,' *European Journal of Public Health*, 7, 379-84.
- Singh, H. (2007). Confronting colonialism and racism: Fanon and Gandhi. *Human Architecture: Journal of the Sociology of Self-Knowledge*, 5(3), 31.
- Solorzano, D., Ceja, M., & Yosso, T. (2000). Critical race theory, racial microaggressions, and campus racial climate: The experiences of African American college students. *Journal of Negro Education*, 60-73.
- Solorzano, D. G., & Yosso, T. J. (2001). From Racial Stereotyping and Deficit Discourse toward a Critical Race Theory in Teacher Education. *Multicultural Education*, 9(1), 2-8.
- Stolke, V. (1995). 'Talking Culture: New Boundaries, New Rhetorics of Exclusion in Europe', *Current Anthropology* 36(1): 1-24.
- Storhaug, H. (2003). Human Visas: A Report from the Front Lines of Europe's Integration Crisis. *Human Rights Service*.
- Taguieff, P.A. (1988). *La France du Préjugé. Essai Sur le Racisme et Ses Doubles*. Pris: La Découverte. doi:10.3817/0390083109
- Ueland, A. (2013, 6. March). Increased immigration puts welfare state sustainability in question. *The Foreigner*. Retrieved 2014, August 12, from <http://m.theforeigner.no/pages/columns/increased-immigration-puts-welfare-state-sustainability-in-question/>
- Ullén, M. (2012). 'Utøya 2083, Terror, Performatives, and the Rhetorical Situation. Narratives of Risk, Narrative Des Risikos: *Interdisciplinary Studies*, Interdisziplinäre Beiträge, 339.
- Valdes, F., Mccristal Culp, J. And Harris, A. (2002) 'Battles waged, won, and lost: Critical Race Theory at the turn of the millennium', in Francisco Valdes et al. (eds), *Crossroads, Directions, and a New Critical Race Theory*, Philadelphia: Temple University Press, 1- 6.
- Van Dijk, T. A. (1992). Discourse and the denial of racism. *Discourse & Society*,3(1), 87-118.
- Wetherell, M., Taylor, S., & Yates, S. J. (Eds.). (2001). *Discourse as data: A guide for analysis*. London: Sage.
- Wiggen, M. (2012). Rethinking Anti-Immigration Rhetoric after the Oslo and Utøya Terror Attacks. *New Political Science*, 34(4), 585-604.
- Wikan, U. (1999). Debate. Culture in the nation and public opinion: a Norwegian case Culture: A new concept of race. *Social Anthropology*, 7(1), 57-64.
- Wills, J. (1996). Who needs multicultural education? White students, U.S. history, and the construction of a usable past. *Anthropology and Education Quarterly*, 27, 365–389.

- Winant, H. (2000). Race and race theory. *Annual Review of Sociology*, 169-185.
- Wodak, R., & Reisigl, M. (1999). Discourse and racism: European perspectives. *Annual Review of Anthropology*, 175-199.
- World Health Organization (1986). Ottawa charter for health promotion. Ottawa: *Canadian Public Health Association*.
- Tollerud, E. (2011, 18. October). Vondt at muslimer fikk skylden. Aftenposten. Retrieved 2014, August 12, from <http://www.aftenposten.no/nyheter/iriks/--Vondt-at-muslimer-fikk-skylden-5014979.html>
- Volpp, L. (2001). Citizen and the Terrorist, The. *University of california Law Review.*, 49, 1601.
- Østlie, K. (2012, 28. January). Jakten på rasistvolden etter 22.juli. Aftenposten. Retrieved 2014, August 12, from <http://www.aftenposten.no/nyheter/iriks/Jakten-pa-rasistvolden-etter-22juli-6751209.html>

## Appendix A

### Transcription symbols

Note: The Norwegian audio-recordings were transcribed phonetically to capture dialect.

#### Unit

- |                    |       |
|--------------------|-------|
| 1. Word            | space |
| 2. Intonation unit | line  |

#### Pause

- |                           |       |
|---------------------------|-------|
| 3. Pause, timed (seconds) | (1.2) |
| 4. Pause, short           | (.)   |
| 5. Lag (lengthened word)  | :     |
| If very long lag          | :::   |

#### Sequence

- |                       |     |
|-----------------------|-----|
| 6. Overlapping speech | [ ] |
|-----------------------|-----|

#### Disfluency

- |                             |      |
|-----------------------------|------|
| 7. Truncated / word cut off | wor- |
|-----------------------------|------|

#### Vocalism

- |                   |                      |
|-------------------|----------------------|
| 8. Breath in      | .hhh                 |
| 9. Exhale         | hhh                  |
| 10. Vocalism      | (sniff) (cough), etc |
| 11. Click         | (tsk)                |
| 12. Laugh pulse   | @                    |
| 13. Laughing word | wo@rd                |

#### Manner Quality

14. Voice of another (vox) <VOX>words<VOX>

15. Quiet, attenuated, whisper °words°

16. Smile quality <SM>words<SM>

### Metatranscription

17. Unintelligible ###time-code

18. Uncertain (words time-code)

19. Comment ((words))

### Participation

20. Speaker attribution Elin:

21. Unidentified speaker ():

22. Uncertain speaker (Elin):

### Boundary closure

23. Terminative .

24. Continuative ,

25. Truncated intonation unit --

26. Appeal/question (final) ?

27. Appeal (continuing) ?,

### Prosody

28. Primary accent ^word

29. Secondary accent 'word

30. Forte (loud) WORD

31. High pitch ↑ word / word ↑

32. Low pitch ↓ word / word ↓



**Appendix B**

*Classroom layouts*

Fig 1.1

Lecture 30/08/13

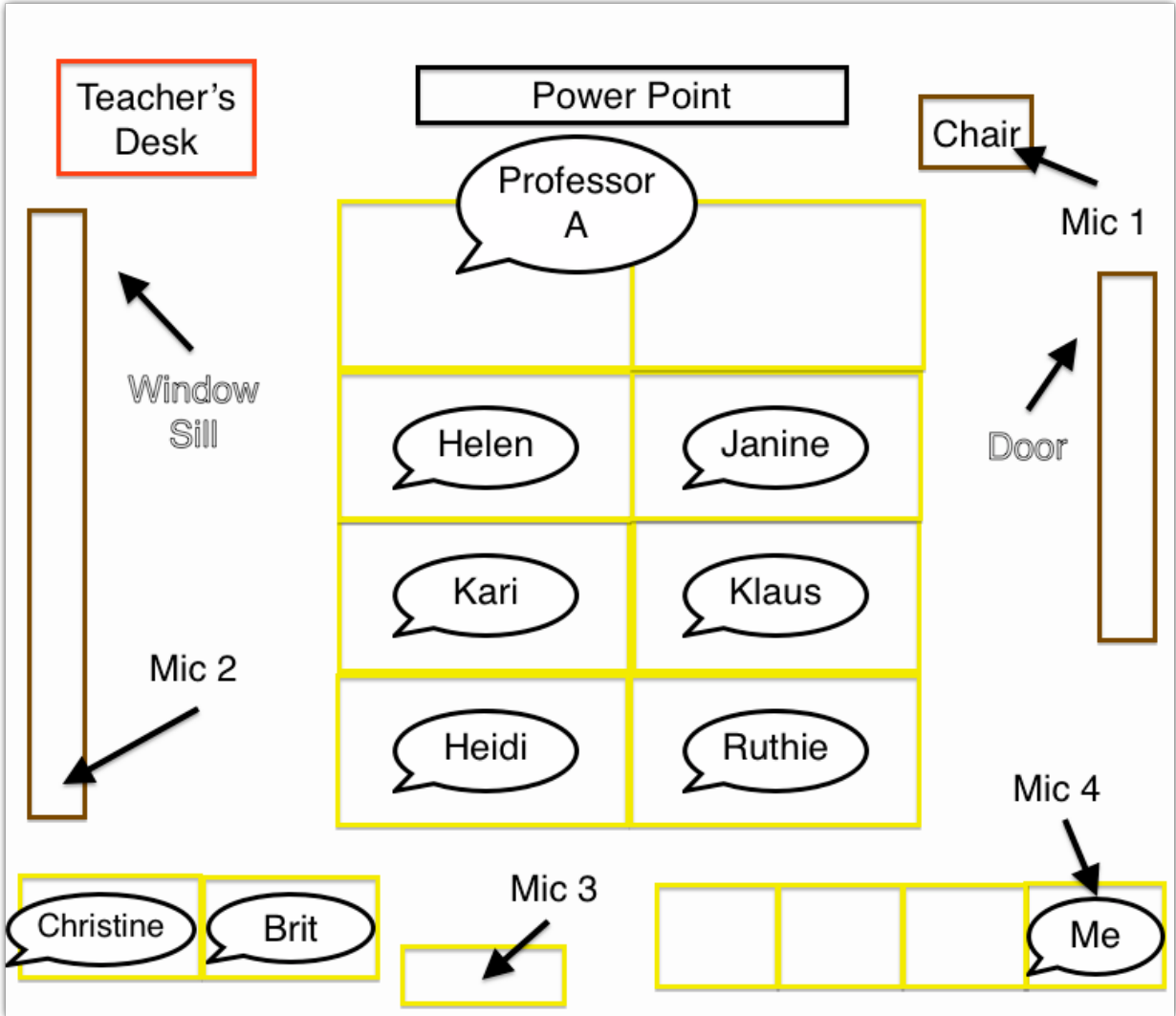

Fig 1.2

Lecture 13/09/13

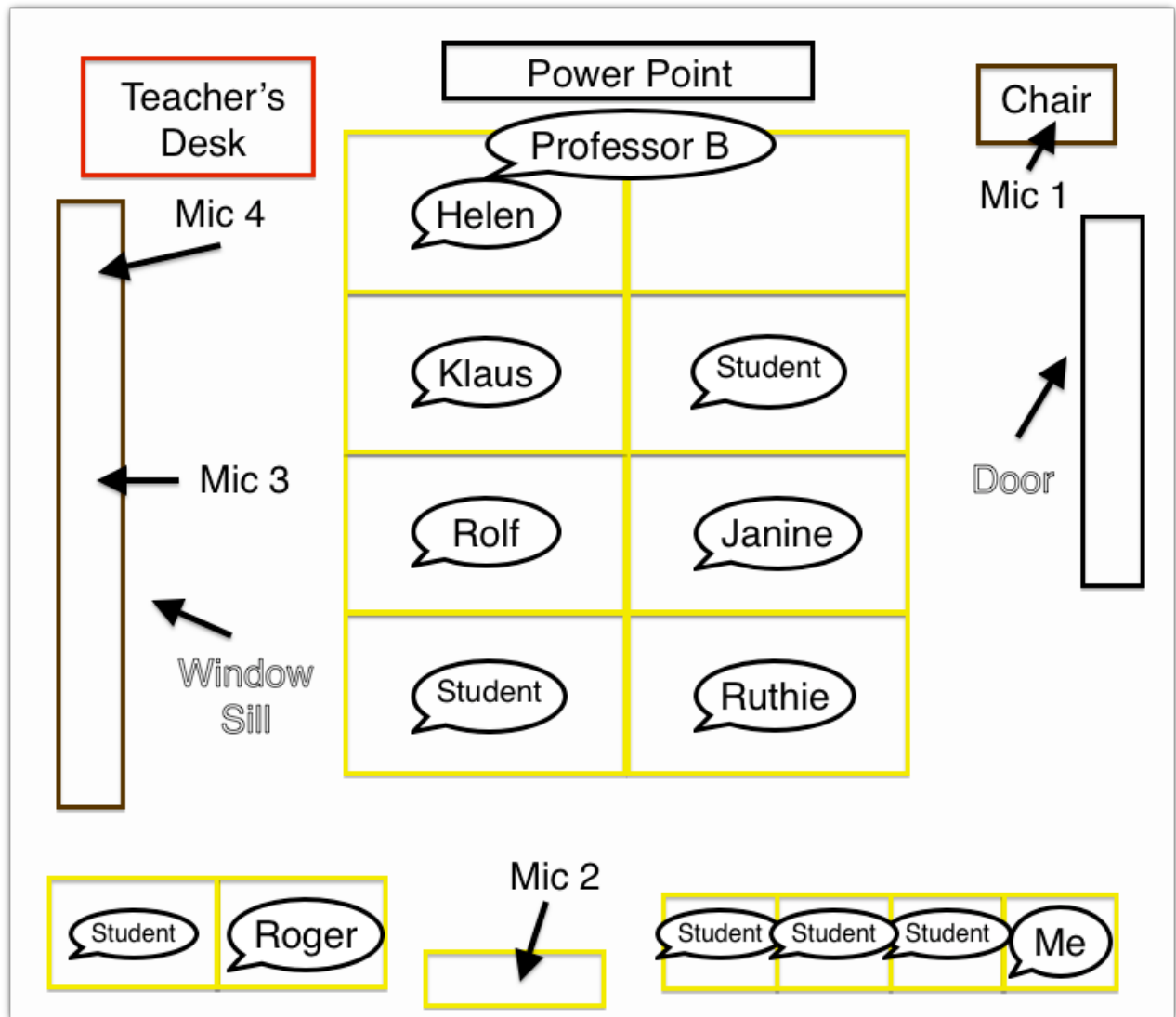

Fig 1.3

Colloquium 20/09/13

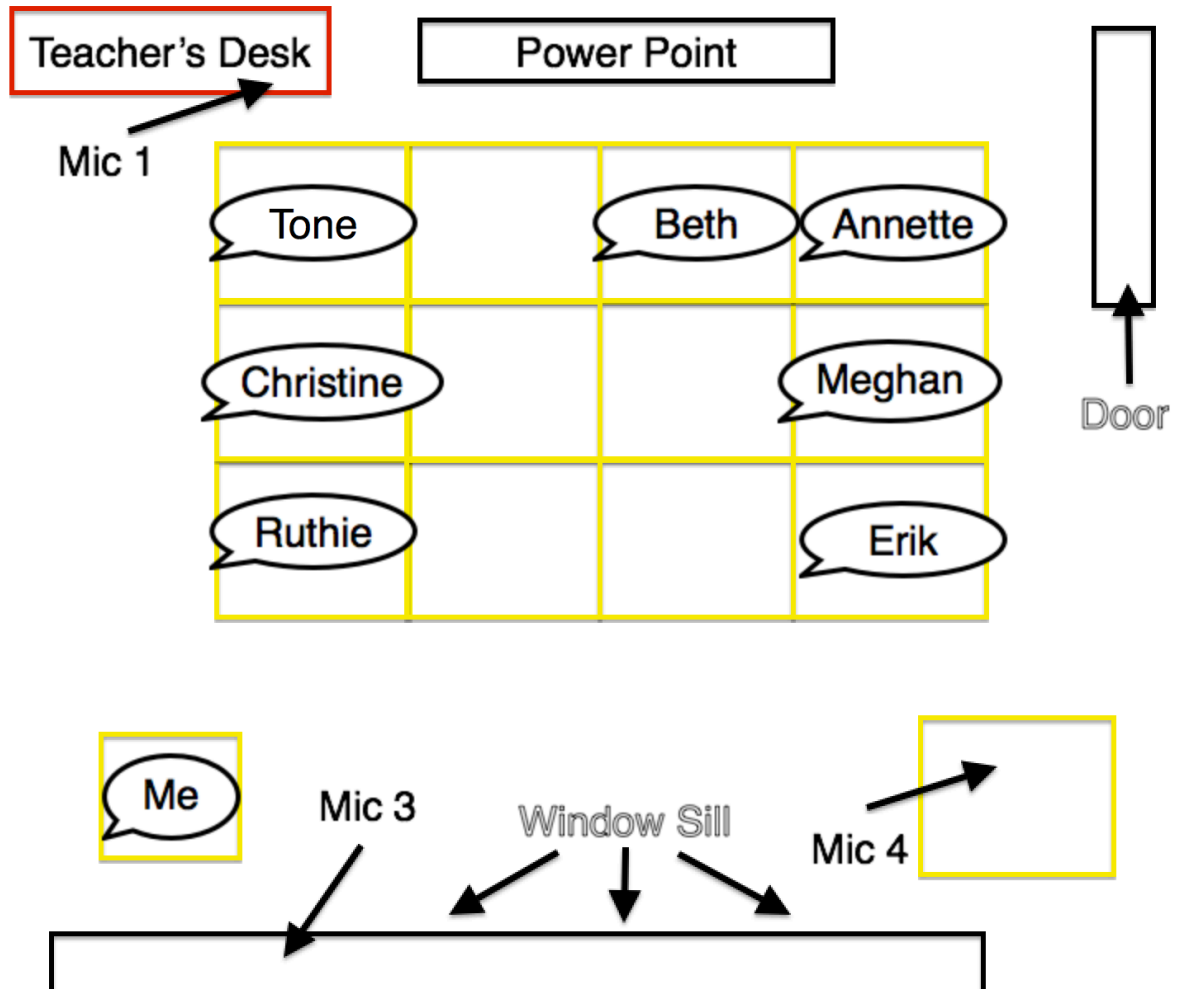
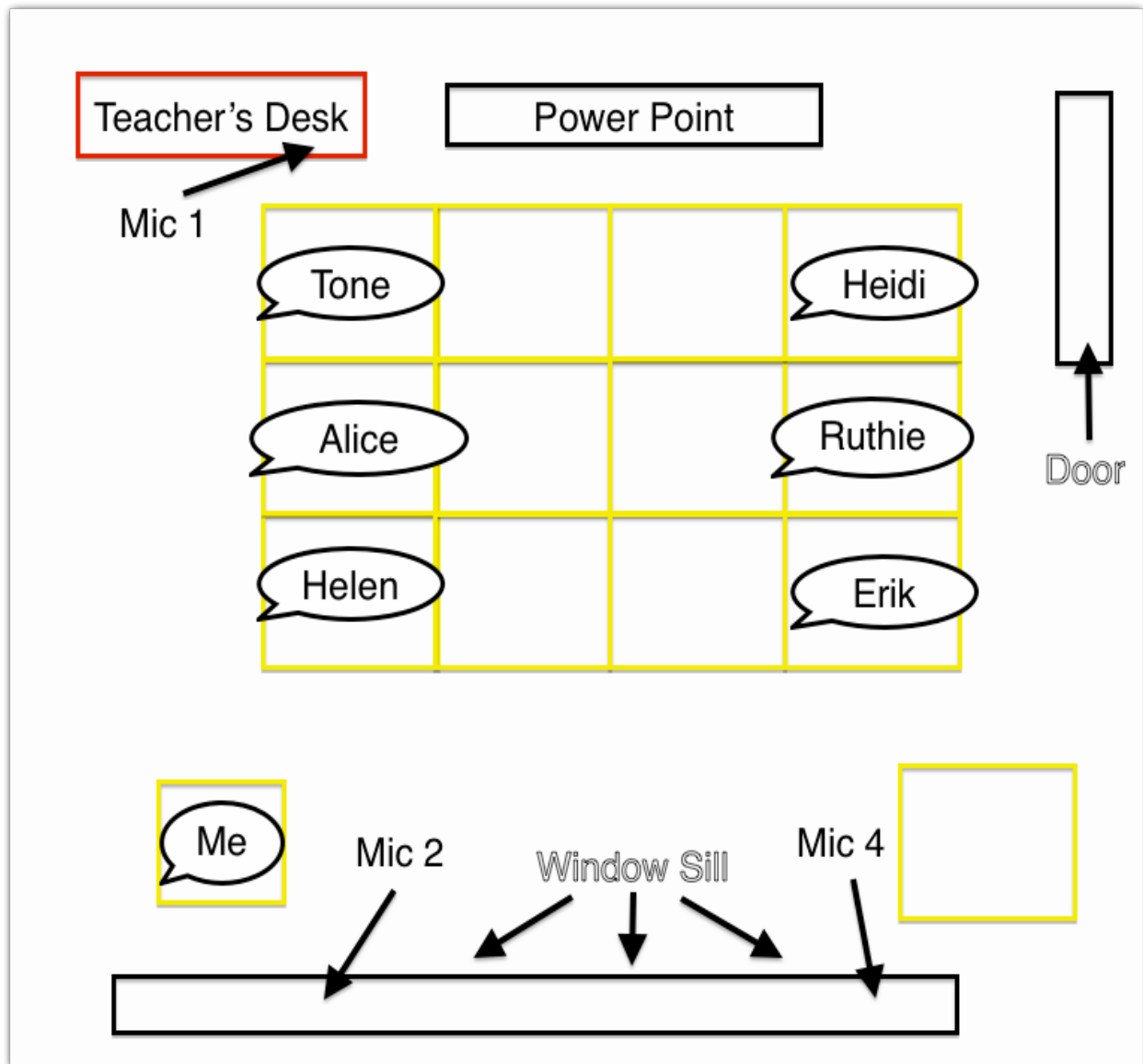

Fig 1.4

Colloquium 27/09/13



## Appendix C

### Informed Consent

Dette semesteret er kurset en del av et EU-prosjekt. Målet med prosjektet er å forstå hvordan tema som forskjell, identitet, tilhørighet og eksklusjon diskuteres i universitetsundervisning, både på forelesninger og seminarer. Vi ønsker å se hvordan vi i diskurs omtaler annerledeshet og avvik fra den norske "normen", med mål om å bidra til økt forståelse for, og debatt om, det man kaller mangfold. Dette kurset er et av 6-8 kurs på 2 universiteter som blir inkludert i prosjektet.

Vår deltakelse innebærer ingen endringer i kurset. Vi er her kun for å høre og å samle data om diskusjoner dere har knyttet til temaene forskjell, identitet, tilhørighet og eksklusjon. Dette innebærer at jeg eller en annen forsker er tilstede under mange av forelesningene og seminarene. Jeg kommer til å ta lydopptak og notater, men IKKE videoopptak. Notatene vi tar er kun for å forstå lydopptakene, og vil ikke omhandle dere som individer. Et eksempel er å ta notater av powerpoint dersom dette vises. Jeg kommer for eksempel også til å ta notater når folk snakker samtidig fordi det kan være forvirrende og utfordrende å høre hva som blir sagt på lydopptak i ettertid.

Vi kommer ikke til å skrive ned navn på studenter. Om et navn kommer med på et båndopptak vil det ikke dokumenteres. Ingen navn vil stå i skriftlige rapporter, artikler eller bøker. Kun eventuelle karakteristikker som kjønn vil bli registrert, dersom det er av betydning for prosjektet. Vi har ikke interesse av å samle data om dere som individer. Vi er kun interessert i de ulike måtene temaene våre blir diskutert på universitetet.

Norsk samfunnsvitenskapelig datatjeneste's Personvernombud for forskning er varslet og har besluttet at det innfrir nødvendige forskningsetiske betingelser.

Hvis dere har spesifikke spørsmål om prosjektet kan dere spørre meg eller jeg kan gi dere kontaktinformasjon til veilederen min

Tusen takk.

## Appendix D

### Professor/colloquia leader written consent

#### **Samtykkeerklæring**

Du inviteres med dette til å delta i et prosjekt som har som målsetting å forstå hvordan tema som forskjell, identitet, tilhørighet og eksklusjon diskuteres i universitetsundervisning, både forelesninger og seminarer. Prosjektet har EU finansiering. Forskerne som har ansvar for prosjektet er PhD Yael Harlap og PhD Hanne Riese fra Institutt for Pedagogikk ved Det Psykologiske fakultet. Ved å sette søkelys på hvordan vi i diskurs omtaler annerledeshet og avvik fra den norske ”normen”, håper vi at prosjektet kan bidra til økt forståelse for det man kaller mangfold, både på universitetet og i samfunnet generelt. Videre er vårt ønske å bidra til en mer informert debatt omkring disse temaene.

For å gjennomføre prosjektet ønsker vi å gjennomføre deltakende observasjon på forelesninger og seminarer på til sammen 8 til 12 emner ved Universitetet i Bergen og Oslo, med siktemål å skaffe datamateriale til analyse av diskurser om forskjell. Dersom ditt emne kan inkluderes i prosjektet vil vi be om å få være tilstede på mellom 50 og 80 prosent av forelesningene og seminarene i det semesteret kurset går. Observatøren vil være en forskningsassistent eller en av de to forskerne som har ansvar for prosjektet, og vedkommende vil sitte blant studentene og notere. I tillegg vil observatøren montere én til to mikrofoner/båndopptakere i lokalet for lydopptak av sekvensen. Observatøren vil be om å få noen minutter innledningsvis (på de første samlingene der det gjøres observasjon) til å gjøre studentene på emnet kjent med prosjektet og vilkårene for datainnsamlingen (i henhold til etiske forskningsstandarder).

Som emneansvarlig står du fritt til å velge om ditt emne skal delta i prosjektet, og du kan på et hvilket som helst tidspunkt trekke emnet fra deltakelse i prosjektet. Alle lydopptak vil bli behandlet konfidensielt og opplysninger som samles inn vil anonymiseres. Dersom du trekker kurset fra deltakelse i prosjektet vil alle innsamlede data bli slettet.

Vi er klar over at det akademiske miljøet og Universitetet er lite. Dermed vil det alltid kunne være en risiko for at det som kommer fram i datainnsamlingen kan gjenkjennes til tross for at vi vil gjøre vårt ytterste for å anonymisere informasjon. Dersom du ønsker det kan du få anledning til å gi ditt perspektiv på tolkninger av data når vi har bearbeidet materialet vi har samlet inn.

Dersom du vil la oss observere ditt emne er det fint om du signerer samtykkeerklæringen under. Hvis du har spørsmål eller ønsker mer informasjon om prosjektet så kan du kontakte Yael Harlap.

**Samtykkeerklæring:** Jeg har mottatt skriftlig informasjon og er villig til å delta i studien.

<hr/>	<hr/>	<hr/>
Navn	Signatur	Dato

Med vennlig hilsen,

Yael Harlap, PhD  
Førsteamanuensis, Institutt for  
Pedagogikk  
Christiesgate 13.  
yael.harlap@uib.no, Tlf: 942 13 004

Hanne Riese, PhD  
Førsteamanuensis, Institutt for Pedagogikk  
Christiesgate 13.  
hanne.riese@uib.no, Tlf: 55 58 88 66