



ELSEVIER

Contents lists available at ScienceDirect

Consciousness and Cognition

journal homepage: www.elsevier.com/locate/concog

The relationship between strategic control and conscious structural knowledge in artificial grammar learning



Elisabeth Norman^{a,*}, Ryan B. Scott^b, Mark C. Price^a, Zoltan Dienes^b

^a Faculty of Psychology, University of Bergen, Christiesgate 12, 5015 Bergen, Norway

^b School of Psychology, University of Sussex, Falmer, Brighton BN1 9RH, United Kingdom

ARTICLE INFO

Article history:

Received 9 December 2015

Revised 14 March 2016

Accepted 22 March 2016

Available online 4 April 2016

Keywords:

Implicit learning

Artificial grammar learning

Control

Strategic control

Flexibility

Consciousness

Awareness

Unconscious knowledge

Decision strategy

ABSTRACT

We address Jacoby's (1991) proposal that strategic control over knowledge requires conscious awareness of that knowledge. In a two-grammar artificial grammar learning experiment all participants were trained on two grammars, consisting of a regularity in letter sequences, while two other dimensions (colours and fonts) varied randomly. Strategic control was measured as the ability to selectively apply the grammars during classification. For each classification, participants also made a combined judgement of (a) decision strategy and (b) relevant stimulus dimension. Strategic control was found for all types of decision strategy, including trials where participants claimed to lack conscious structural knowledge. However, strong evidence of strategic control only occurred when participants knew or guessed that the letter dimension was relevant, suggesting that strategic control might be associated with – or even causally requires – global awareness of the nature of the rules even though it does not require detailed knowledge of their content.

© 2016 The Authors. Published by Elsevier Inc. This is an open access article under the CC BY-NC-ND license (<http://creativecommons.org/licenses/by-nc-nd/4.0/>).

1. Introduction

The ability to strategically control the influence of knowledge on behaviour is regarded by many as indicating that the knowledge is conscious (e.g., Baars, 1988; Jacoby, 1991). However, this assumption has been challenged by empirical findings showing that unconsciously perceived stimuli can interfere with tasks traditionally thought to require strategic control (Lau & Passingham, 2007; Schmidt, Crump, Cheesman, & Besner, 2007; Van Gaal & Lamme, 2012; Van Gaal, Ridderinkhof, Scholte, & Lamme, 2010). The idea of unconscious executive control is also inherent in Dienes and Perner's (2007) cold control theory of hypnosis. In the present study we address whether and to what extent strategic control over the application of 2 rule sets in artificial grammar learning (AGL; Reber, 1967) requires conscious structural knowledge of those rule sets.

Strategic control can be measured by comparing performance in situations where the person tries versus tries not to engage in some act, i.e. situations that require “opposition logic”. For example, Jacoby's (1991) Process Dissociation Procedure aims to identify dissociations between automatic and intentional application of knowledge by comparing performance under conditions where participants are instructed to apply, versus withhold, certain knowledge. This logic has been applied to implicit learning experiments, including artificial grammar learning (AGL; Reber, 1967, 1993). In AGL, participants initially observe or memorize a series of nonword letter strings where the identity and order of letters is determined by a complex

* Corresponding author.

E-mail addresses: Elisabeth.Norman@uib.no (E. Norman), r.b.scott@sussex.ac.uk (R.B. Scott), Mark.Price@uib.no (M.C. Price), Z.Dienes@sussex.ac.uk (Z. Dienes).

finite-state grammar. After this training phase they are told that all letter strings followed a complex set of rules, referred to as a grammar. In a subsequent test phase they judge the grammaticality of a series of novel letter strings.

Consciousness of acquired knowledge can be assessed by various subjective awareness measures (Pasquali, Timmermans, & Cleeremans, 2010; Sandberg, Timmermans, Overgaard, & Cleeremans, 2010). If participants are trained on two different grammars, strategic control can be measured by asking them to selectively apply their knowledge of one of these grammars over a given block of test trials (Dienes, Altmann, Kwan, & Goode, 1995; Wan, Dienes, & Fu, 2008; see also Higham, Vokey, & Pritchard, 2000). An alternative procedure – argued to require a higher degree of strategic control – is to let the classification rule vary randomly between individual trials (Norman, Price, & Jones, 2011). Translated to opposition logic, such classification judgements require the “inclusion” of strings that follow the target grammar and “exclusion” of strings that follow the irrelevant grammar. The same logic has been applied to implicit sequence learning in the serial reaction time (SRT) task (Nissen & Bullemer, 1987). Here strategic control is measured as the ability to avoid generating regularities from the trained sequence under exclusion as opposed to under inclusion instructions (Destrebecqz & Cleeremans, 2001; Fu, Fu, & Dienes, 2008; Goschke, 1998; Jiménez, Vaquero, & Lupiáñez, 2006; Wilkinson & Shanks, 2004). More demanding, it has been measured as participants’ ability to indicate anticipated target positions when the instructed relation between the spatial location of the anticipated target and the spatial location of a manual response varies across trials (Norman, Price, Duff, & Mentzoni, 2007). Using these procedures, strategic control has been identified both in AGL and SRT learning.

One of Jacoby’s central assumptions, which is consistent with Baars’ (1988) Global Workspace Theory, is that strategic control over the application of knowledge requires conscious awareness. In memory experiments, this is taken to specifically require conscious recollection of previously exposed stimuli. One example is word stem completion under exclusion instructions, where participants complete a series of word stems with words that have not been presented earlier (Jacoby, Toth, & Yonelinas, 1993). According to Jacoby et al., the controlled suppression of a word that comes to mind during this task requires participants to consciously recollect having seen the word during training. This in turn requires accurate source identification – i.e., that one consciously attributes generated words to previous exposure (Buchner, Erdfelder, Steffens, & Martensen, 1997; Yu & Bellezza, 2000). In contrast, words that come to mind which are not attributed to previous exposure are more likely to be reported contrary to instruction.

In the current paper we explore the extent to which strategic control over the application of two learned grammars in AGL is limited to instances where participants attribute their classification responses to conscious decision strategies, and/or where there is conscious awareness of which stimulus dimension was relevant to the grammaticality decision. The question is relevant to the proposed distinction between two forms of knowledge that may be acquired in AGL: (a) judgement knowledge – i.e. knowledge of *whether* a certain letter string is grammatical, and (b) structural knowledge – i.e. knowing the *detailed structure* of the grammar (Dienes & Scott, 2005). What we ask is whether and to what extent the ability to strategically control one’s grammaticality judgement requires *conscious* structural knowledge.

In AGL, whether structural knowledge of grammar rules is conscious or unconscious can be assessed in at least two different ways. First it can be assessed by asking participants, on every test trial, to report the decision strategy they used to arrive at their classification judgement (Dienes & Scott, 2005). If participants report using “explicit rules” or “memories” one would infer the involvement of conscious structural knowledge. However if they report using “random choice”, “intuition”, or “familiarity”, commonly referred to as “implicit” decision strategies, one would infer that any above-chance classification performance reflected unconscious structural knowledge (Scott & Dienes, 2008). In both SRT and AGL experiments, it has been found that strategic control can occur even for decisions attributed to implicit strategies (Fu, Dienes, & Fu, 2010; Wan et al., 2008). Second, whether structural knowledge of grammar rules is conscious or unconscious can be assessed by asking participants to identify which stimulus dimension(s) are relevant to the learned rules. If participants report that the rules were related to a dimension that was indeed relevant to the rules, e.g., the selection and ordering of letters in AGL, one would infer that they might have conscious structural knowledge. By contrast, the unconscious nature of structural knowledge could be safely inferred if participants report that they thought the rules were related to stimulus dimensions that were in fact irrelevant. For instance, if letter strings in AGL contained additional random variation in colour which was irrelevant to the grammar, a participant truthfully attributing the rule to colour variations only, would not have correct conscious structural knowledge. There is already some evidence that even participants who misattribute the nature of acquired rules to irrelevant stimulus properties may still strategically control the application of knowledge, both in AGL (Norman et al., 2011) and SRT experiments (Norman et al., 2007).

It may be argued that the two measures reflect different properties of structural knowledge: Self-reported decision strategy reflects the extent to which participants feel they applied conscious structural knowledge and/or conscious judgement knowledge, whereas reported rule-dimension awareness, i.e., the extent to which participants reported that their decision involved the letter dimension, reflects the accuracy of participants’ hypotheses about of the nature of the grammar. The two may often converge, as when making an intuitive judgement relating to an irrelevant stimulus dimension, which would be a strong indication that structural knowledge was indeed unconscious, or conversely applying a conscious rule that relates to a relevant stimulus dimension. However, the two may also diverge. For instance, a consciously applied rule may well relate to one or more irrelevant stimulus properties (e.g., “when a word contains many purple letters and at least one letter is written in italics it must belong to Grammar A”).

It could also be argued that used individually, both measures have limitations. First, they reflect different properties of structural knowledge: Self-reported decision strategies reflect whether participants feel they *applied* conscious versus unconscious structural knowledge, whereas reported rule awareness reflects whether the *content* of participants’ hypotheses

about the nature of the rule indicate conscious or unconscious structural knowledge. Second, because both approaches rely on the absolute accuracy of participants' relatively complex metacognitive appraisals of their own performance, they are potentially subject to response bias. Used in combination, the two measures could provide a more conservative criterion of unconscious structural knowledge, namely that two forms of "source misattribution" must be jointly present.

Used in combination, the two measures could provide an assessment of the extent to which structural grammar knowledge is conscious or unconscious that does not contain these limitations. If strategic control is found also in cases when structural knowledge is unconscious according to both criteria in combination, this would provide strong evidence against Jacoby's view. If one but not the other measure of consciousness over structural knowledge is required for strategic control to occur, a combination of the two would give us more refined insight into what, if any, form of conscious structural knowledge must be present in order for people to be able to apply knowledge strategically.

In the reported experiment we explored the extent to which strategic control of grammar classifications required conscious structural knowledge when both criteria are applied. Following Norman et al. (2011), the classification rule varied randomly between grammars across individual trials. Additionally, the true nature of the grammars (only governed by letter identity and order) was disguised by constructing letter strings that contained random variation on stimulus dimensions (colour, font) that were unrelated to the artificial grammars. The difference between this procedure and previous AGL procedures applying multi-dimensional stimuli (Eitam, Schul, & Hassin, 2009) is therefore that only one dimension was relevant to the rules. To measure whether structural knowledge was conscious or unconscious we applied a combined trial-by-trial self-report measurement of decision strategy and of which stimulus dimension the classification decision related to.

If participants showed strategic control on trials that were both attributed to implicit decision strategies and to stimulus dimensions other than letters i.e., when claiming to be unaware of the structural aspects of the stimuli that motivated their decision – this would support the hypothesis that unconscious structural knowledge can be strategically applied, and thereby challenge Jacoby's (1991) assumption that strategic control depends on conscious awareness. If strategic control depended on conscious structural knowledge as measured by a combination of the two measures, i.e., if it only occurred on trials where participants felt that they were applying conscious rule knowledge related to the relevant stimulus dimension, this could be taken to support Jacoby's assumption.

2. Method

120 Norwegian students (60 females, 60 males) aged 18–41 ($M = 22.5$, $SD = 3.0$) took part in two training phases. In each phase they viewed letter strings from a different finite-state grammar (grammar A versus B, order counterbalanced across participants). Grammars and letter strings were taken from Dienes et al. (1995, see Fig. 1). The AGL task was programmed in E-prime 2.0 (Schneider, Eschman, & Zuccolotto, 2002a, 2002b) and displayed by a 19" monitor. In each training phase, each of 32 letter strings was presented three times, one at a time, in random order.

Strings consisted of 5–9 letters (X, V, M, R, T), with each letter written on one of five coloured backgrounds (red, purple, blue, green, black) and in one of five different font styles (bold, italics, normal, outline, underline). Colour and font of each letter varied randomly (see Fig. 2). Instructions were to examine each string closely during its 7500 ms display period. To ensure participants attended all 3 stimulus dimensions, they were cued post-trial to report either the letter (8 trials), colour (8 trials), or font (8 trials) of a randomly chosen string element on 24 randomly selected trials in each training phase. This and all other responses were indicated by a mouse click. After the two training phases, participants were informed that letter strings were governed by a different complex rule in each phase. On each of 60 subsequent test trials, three novel letter strings were presented simultaneously in a vertical column – one grammar A string, one grammar B string, and one ungrammatical string. Each string type occurred equally often in each screen position (i.e., upper, middle and lower). Following the procedure by Norman et al. (2011), participants' task was to select either the string obeying grammar A or grammar B item, with target grammar varying randomly between individual trials and indicated by a written cue ("Rule 1"/"Rule 2?") displayed above the letter strings.

After each classification judgement participants made a two-step trial-by-trial evaluation of decision strategy. The first step was a multiple-choice evaluation of decision strategy with 3 alternatives presented in a vertical row on the screen, namely "random choice", "feelings (of intuition or familiarity)", or "rule/specific memory". The "implicit" decision strategies "random choice", and "feelings" represent claims by participants that they were not aware of the structural aspects of the stimuli that motivated their decision (i.e., any structural knowledge was unconscious). Trials attributed to "feelings" differ from those attributed to "random choice" because, in the former case, the participant claims to be aware of knowing whether they categorized correctly, even if they do not know why (i.e., judgment knowledge is conscious in the former but not latter case). The "explicit" decision strategy "rule/specific memory" (henceforth "explicit strategies") represents claims by participants that they were aware of relevant structural properties and indicate that both judgement knowledge and structural knowledge are conscious. (See Dienes (2008, 2012) for further explication of structural and judgment knowledge.) After making this decision they were asked to indicate which stimulus dimension(s) they thought were relevant to their decision. The response alternatives "letters", "colours", and "fonts" (with the order counterbalanced across participant) were presented below each decision strategy category. For "random choice" and "feelings", participants were instructed that if they did not think/feel that any particular dimension(s) was/were relevant, they were supposed to guess the relevant dimension (s). Trials where participants attributed their decision to letters (alone or in combination with other dimensions) were

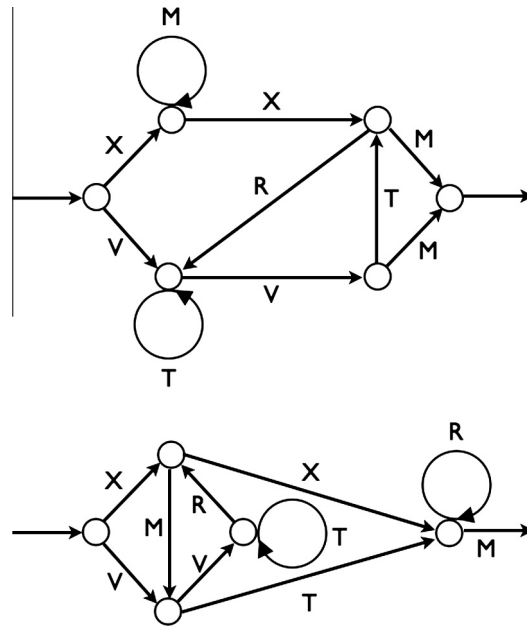

Fig. 1. The two finite-state grammars used in the experiments, grammar A (top), and grammar B (bottom).

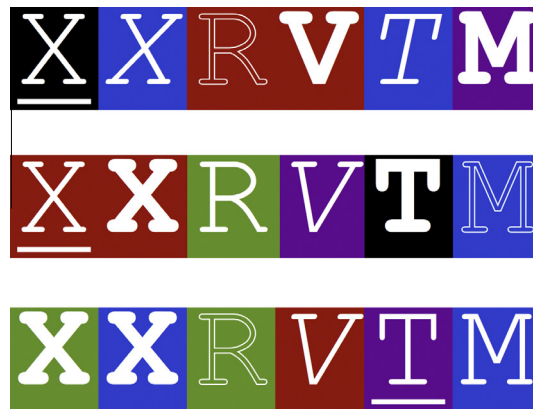

Fig. 2. Three different examples of how the letter string “XXRVTM” (grammar A, Dienes et al., 1995) may appear with random variation in colour and font. (For interpretation of the references to colour in this figure legend, the reader is referred to the web version of this article.)

classified as *correct dimension trials*, and the remainder as *misattributed dimension trials*. After the test phase, participants received a questionnaire in which they were instructed to allocate 12 points between the three stimulus dimensions (letter, colour, font) in a way that reflected the extent to which they thought each dimension had contributed to the grammar rules. Conservatively, only participants who allocated 0 points to letter were classified as *unaware*, and all others were classified as *potentially aware*.

3. Results

The mean percentage of trials on which participants reported the correct letter, colour, or font of a randomly chosen string element during the training phase was high ($M = 85.6$, $SD = 10.0$), indicating that participants were attending to all 3 stimulus dimensions.

Strategic control was expressed as *strategic scores* (Dienes et al., 1995), defined as the proportion of *consistent* strings chosen out of all consistent and inconsistent strings. A consistent string is one that follows the target grammar, while an inconsistent string is one that follows the nontarget grammar.¹ Strategic control over the application of the two grammars would result in scores above the .5 chance level.

¹ A flattening constant of 0.5 was used: Proportions were calculated as $(\text{consistent} + 0.5) / (\text{consistent} + \text{inconsistent} + 1)$, corresponding to a Bayesian prior belief worth one observation that the proportion is 0.5.

Table 1

Means and statistics for the different response categories. Values are reported for all participants, and also separately for unaware participants.

	<i>N</i> ^a	Strategic score <i>M</i> (<i>SD</i>) [<i>CI</i> ₉₅] <i>B</i> _{H[0,.10]}	<i>t</i> -test compared to chance (.5) <i>t</i> (<i>df</i>) <i>p</i> (2-tailed)	Cohen's effect size <i>d</i> [<i>CI</i> ₉₅]
<i>All participants</i>				
Random + correct dimension	73	.55 (.16) [.51, .59] 7.86	2.70 (72) .01	.32 [.08, .55]
Feelings + correct dimension	77	.57 (.17) [.53, .61] 141.63	3.53 (76) .001	.40 [.16, .63]
Explicit + correct dimension	53	.60 (.24) [.54, .67] 93.90	3.17 (52) .003	.44 [.15, .72]
Random + incorrect dimension	70	.47 (.20) [.42, .52] .08	−1.25 (69) .22	−.15 [−.38, .09]
Feelings + incorrect dimension	65	.53 (.20) [.48, .58] 1.08	1.20 (64) .24	.15 [−.10, .39]
Explicit + incorrect dimension	30	.52 (.21) [.45, .60] .56	.65 (29) .52	.12 [−.24, .48]
<i>Unaware participants</i>				
Random	20	.51 (.14) [.44, .57] .38	.18 (19) .86	.04 [−.40, .48]
Feelings	19	.57 (.16) [.49, .64] 2.64	1.80 (18) .09	.41 [−.06, .88]
Explicit	12	.54 (.22) [.41, .68] .87	.70 (11) .50	.20 [−.37, .77]

^a Note: *N* differs between cells according to how many participants had responses within response category in question.

Analyses involving strategic scores included only the 85/120 participants who showed learning, i.e., who chose ungrammatical letter strings on less than a third of the trials. In addition, 4 of these participants who were defined as outliers because their mean strategic score was more than 2SD above the group mean, were also excluded from the analyses.

To examine the relationship between strategic control and awareness of the relevant dimension we compared strategic scores for trials on which the person chose the letter dimension, alone or in combination with other dimensions, with strategic scores for trials on which the person did not choose the letter dimension. A dependent sample *t*-test showed evidence of higher strategic scores on trials correctly attributed to letters [$t(72) = 2.98, p = .004, B_{H[0,.10]} = 31.44$].²

Secondly, we compared participants' strategic scores to the chance level of .5 for 6 different types of trial; i.e., trials on which the three different types of decision strategy were given, either under conditions where the correct stimulus dimension was reported or under conditions where the correct stimulus dimension was not reported. Detailed results are presented in Table 1. We report confidence intervals on effect sizes and Bayes factors in addition to NHST *p*-values, so that the reader can assess both the strength of evidence and conventional significance levels for any effects (Cumming, 2012; Dienes, 2014).

For random choice, feelings, and explicit trials where the correct stimulus dimension was reported, the Bayes factor was above 3, suggesting substantial evidence for the alternative hypothesis above the null hypothesis (Dienes, 2014, 2015), in this case that strategic control was higher than what would be expected by chance. We also computed the 95% confidence interval (*CI*₉₅) for each of these effect sizes using the CIdeltaIND worksheet of the Exploratory Software for Confidence Intervals (ESCI) that runs under Microsoft Excel and is based on noncentral *t* distributions (Cumming & Finch, 2001). These *CI*₉₅ did not include an effect size of zero for any of the three decision strategies (see also Fig. 3). *T*-tests comparing performance

² $B_{H[0,.10]}$ refers to a Bayes factor used to test the hypothesis that strategic scores are above chance level of .5, represented as a half-normal with a *SD* of .10 above chance level, against the H_0 , the hypothesis of chance performance. The estimated *SD* of .10 was chosen based on data from a comparable previous study (Norman et al., 2011) as well as unpublished data (Norman, Scott, Price, Jones, & Dienes, 2016). A *B* of 3 or above indicates substantial evidence for the alternative above the null hypothesis, a *B* of 1/3 or below indicates substantial evidence for the null above the alternative hypothesis, and a *B* between 1/3 and 3 indicates data insensitivity for distinguishing between the alternative and null hypotheses (Dienes, 2014, 2015).

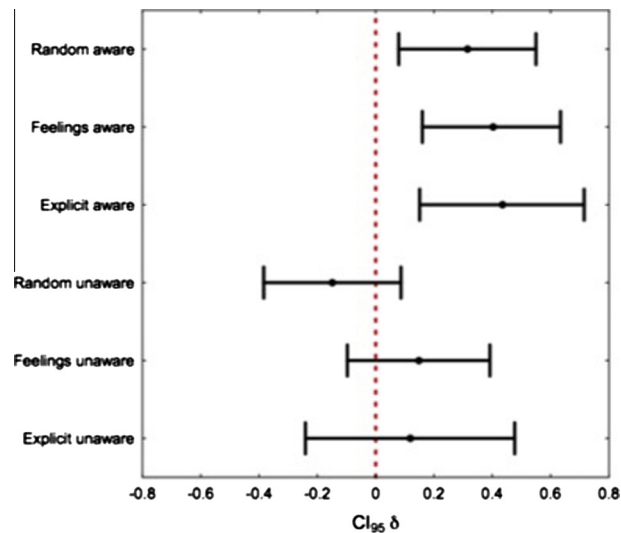

Fig. 3. Comparison of strategic scores to chance for each combination of attribution judgement and rule-dimension awareness, expressed as the point estimates of Cohen's effect size d , and the CI_{95} of their population estimate (δ) for each condition. The red reference line indicates an effect size of zero. (For interpretation of the references to colour in this figure legend, the reader is referred to the web version of this article.)

to a chance level of .5 showed that strategic scores were always significantly above chance when the correct stimulus dimension was reported.

There was less evidence for strategic control when participants reported the incorrect stimulus. For *random choice* trials, the Bayes factor was below 1/3, supporting the null hypothesis, i.e., that strategic scores were not different from chance level on these trials. However, for *feelings* and *explicit* trials on which the correct dimension was not reported, the range of the Bayes factors (1/3–3) indicated insensitivity for distinguishing between the alternative hypothesis and the null hypotheses. An effect size of zero lay within the CI_{95} for all three decision strategies, none of which showed a conventional significance level above chance.

Separate analyses were specifically conducted on the strategic scores of those participants who, when asked about the nature of the grammar rules after the experiment, allocated zero points to the letter dimension (see Table 1). For all three types of decision strategy the range of the Bayes factors (1/3–3) indicated insensitivity, and t -tests showed no strong evidence that strategic control occurred in the absence of conscious awareness.

4. Discussion

Evidence of strategic control occurred for all types of decision strategy, including trials attributed to *random choice*, *feelings*, and *explicit rules/memory*. This suggests that participants were still able to apply their grammar knowledge in a strategic and flexible manner even when they felt that their classification judgements did not involve conscious rule knowledge (i.e., for random choice and feelings trials). The finding is consistent with previous results reported by Wan et al. (2008), where strategic control over the application of two finite-state grammars was reported even for trials attributed to familiarity, intuition, and random choice. It is also consistent with the results of Fu et al. (2010), who reported significant strategic control in SRT learning even on trials attributed to implicit decision strategies, when strategic control was operationalized as the ability to suppress learned sequence regularities on a generation exclusion task.

The novel contribution of our study is that strong evidence of strategic control was limited to trials on which participants attributed their responses to the correct stimulus dimension, alone or in combination with other stimulus dimensions. For trials where the participant expressed that their grammar classification was made on the basis of a *random choice*, this result appears robust. When participants reported the classification to be based on *feelings* or *explicit rules/memory*, the results are qualified by Bayesian analyses; these indicate that data are too insensitive to confidently accept the null hypothesis that participants lack strategic control over grammar classification. Nevertheless our data broadly show that there is more substantial evidence for strategic control when the correct stimulus dimension is reported.

For trials attributed to *explicit* strategies, it is perhaps unsurprising that evidence of strategic control was weaker when the incorrect stimulus dimension was reported. If a participant erroneously responds on the basis of an imagined rule or a misleading memory that are related to an irrelevant dimension (i.e., colour and/or font), poor classification accuracy is exactly what would be predicted.

However our results are at least suggestive that conscious focus on the correct stimulus dimension may also be important during more implicitly guided responses – i.e., on trials attributed to a *random choice* or *feelings*. One interpretation of this is that although strategic control can occur on trials where implicit decision strategies are applied, it nevertheless requires

some conscious insight into the nature of the grammar rules, consistent with [Jacoby's \(1991\)](#) original proposal that strategic control requires a degree of consciousness. Decision strategy and dimension attribution may reflect different properties of structural knowledge. As stressed by [Dienes and Scott \(2005\)](#), structural knowledge is complex and may encompass “knowledge of particular items, knowledge of fragments of items, knowledge of other types of rules, or knowledge embedded in connectionist weights” (p. 339). These may dissociate in terms of their conscious availability and in the extent to which they are associated with strategic control.

An alternative, but perhaps less parsimonious, interpretation is that strategic control is possible without any degree of conscious structural knowledge: On trials attributed to a *random choice* or *feelings*, unconscious structural knowledge might influence not only strategic control, but also judgements of the relevant stimulus dimension. In other words, when participants did not feel that they had structural knowledge, and therefore indicated that they were responding on the basis of a *random choice* or *feelings*, their guess about the relevant dimension could in principle have been influenced by unconscious structural knowledge of the grammars. From this perspective, awareness of stimulus dimension could be seen as a consequence of unconscious structural knowledge rather than as a necessary condition for strategic control. This would be consistent with a recent study by [Mealor, Dienes, and Scott \(2014\)](#) exemplifying how nonconscious priming may create nonspecific, “free-floating familiarity” (p. 231) which in turn may influence classification performance in AGL learning unless its source is made salient. Under this interpretation, our findings would contribute to explorations of how unconscious structural knowledge of artificial grammars may furtively influence people's analytic decisions about the sources of that knowledge.

A third possibility is that strategic control is always mediated by conscious structural knowledge on trials where the correct stimulus dimension is expressed, whatever participants' reported decision strategy. In other words participants' reports that trials were based on a *random choice* or *feelings* may have reflected a response bias instead of being a reliable measure of the contents of their conscious experience. However, we find it unlikely that participants had full conscious insight into the grammar rules, or even that they often had any strong conviction that grammar rules were related to letters. First, the proportion of trials on which participants failed to express full awareness was substantial: On average, participants attributed their classifications to dimensions other than letters (i.e., colours and/or fonts) on more than 1/3 of trials. Second, previous studies have argued that decision strategy judgements are sensitive to differences in conscious rule-knowledge of AGL strings. For instance, the tendency to repeatedly make the same errors across trials has been shown to be more frequent for explicit than implicit decision strategies ([Dienes & Scott, 2005](#)), and the reported basis for grammaticality judgments made for the same test strings at two consecutive time points has been shown to follow a clear pattern of increasing levels of metacognition ([Scott & Dienes, 2010](#)). Third, the relative frequency of the three decision strategy responses in our study did not differ markedly from previous studies where these ratings have been argued to reflect conscious experience in an accurate manner (e.g., [Dienes & Scott, 2005](#)).

The absence of strong evidence for strategic control, during trials that were reported to be based on irrelevant stimulus dimensions, may appear inconsistent with previous findings by [Norman et al. \(2007, 2011\)](#), which have demonstrated strategic control among participants who express unawareness of the correct stimulus dimension on a post-experimental questionnaire and argued that this may be understood as a case of “fringe consciousness”. However, as stressed above, our current data for *feelings* trials that were attributed to incorrect stimulus dimensions were too insensitive to confidently distinguish between the null hypothesis and the possibility of strategic control. It is also possible that our current use of trial-by-trial ratings – by contrast to a single rating made at the end of the experiment – would prompt participants' attention towards the likely nature of the rule. The procedure could encourage people to reflect more about the nature of the rules, to form hypotheses about the rules, and to even “test out” these hypotheses during the test phase by comparing the occurrence of various combinations of stimulus properties across different letter strings. In turn, this would tend to reduce the likelihood that veridical *feelings* would occur in the absence of correct guesses about the rule dimension. The results of the current experiment may not therefore be directly comparable to [Norman et al. \(2007, 2011\)](#), and future studies should consider the extent to which procedural variations may encourage participants to make more analytical or more intuitive decisions.

Our results highlight that greater precision is required in our understanding of what people do not need to be aware of, and what they *do need* to be aware of, if they are to show strategic control over implicit knowledge. Taken together, the weight of evidence from the current experiment indicates that strategic control over implicitly learned AGL strings is associated with conscious awareness of the broad nature of the grammar.

Author note

This research was supported by a project grant from the Meltzer foundation. We thank Oskar Blakstad for his contributions in programming the experiments, and Anna Blomkvist and Simen von Quillfeldt Brekke for help with data collection.

References

- Baars, B. J. (1988). *A cognitive theory of consciousness*. New York, NY: Cambridge University Press.
- Buchner, A., Erdfelder, E., Steffens, M. C., & Martensen, H. (1997). The nature of memory processes underlying recognition judgments in the process dissociation procedure. *Memory & Cognition*, 25(4), 508–517. <http://dx.doi.org/10.3758/BF03201126>.

- Cumming, G. (2012). *Understanding the new statistics: Effect sizes, confidence intervals, and meta-analysis*. New York: Routledge.
- Cumming, G., & Finch, S. (2001). A primer on the understanding, use, and calculation of confidence intervals that are based on central and noncentral distributions. *Educational and Psychological Measurement*, 61(4), 532–574.
- Destrebecqz, A., & Cleeremans, A. (2001). Can sequence learning be implicit? New evidence with the process dissociation procedure. *Psychonomic Bulletin & Review*, 8(2), 343–350. <http://dx.doi.org/10.3758/BF03196171>.
- Dienes, Z. (2008). Subjective measures of unconscious knowledge. *Progress in Brain Research*, 168, 49–64. [http://dx.doi.org/10.1016/S0079-6123\(07\)68005-4](http://dx.doi.org/10.1016/S0079-6123(07)68005-4).
- Dienes, Z. (2014). Using Bayes to get the most out of non-significant results. *Frontiers in Psychology*, 5. <http://dx.doi.org/10.3389/fpsyg.2014.00781>.
- Dienes, Z., Altmann, G. T. M., Kwan, L., & Goode, A. (1995). Unconscious knowledge of artificial grammars is applied strategically. *Journal of Experimental Psychology. Learning, Memory, and Cognition*, 21(5), 1322–1338. <http://dx.doi.org/10.1037//0278-7393.21.5.1322>.
- Dienes, Z. (2015). How Bayesian statistics are needed to determine whether mental states are unconscious. In M. Overgaard (Ed.), *Behavioral methods in consciousness research* (pp. 199–220). London, UK: Oxford University Press.
- Dienes, Z., & Perner, J. (2007). Executive control without conscious awareness: The cold control theory. In G. Jamieson (Ed.), *Hypnosis and conscious states: The cognitive neuroscience perspective* (pp. 293–314). Oxford University Press.
- Dienes, Z. (2012). Conscious versus unconscious learning of structure. In P. Rebuschat & J. Williams (Eds.), *Statistical learning and language acquisition*. Mouton de Gruyter Publishers.
- Dienes, Z., & Scott, R. (2005). Measuring unconscious knowledge: Distinguishing structural knowledge and judgment knowledge. *Psychological Research Psychologische Forschung*, 69(5–6), 338–351. <http://dx.doi.org/10.1007/s00426-004-0208-3>.
- Eitam, B., Schul, Y., & Hassin, R. R. (2009). Goal relevance and artificial grammar learning. *The Quarterly Journal of Experimental Psychology*, 62(2), 228–238. <http://dx.doi.org/10.1080/17470210802479113>.
- Fu, Q., Dienes, Z., & Fu, X. (2010). Can unconscious knowledge allow control in sequence learning? *Consciousness and Cognition*, 19(1), 462–474. <http://dx.doi.org/10.1016/j.concog.2009.10.001>.
- Fu, Q., Fu, X., & Dienes, Z. (2008). Implicit sequence learning and conscious awareness. *Consciousness and Cognition*, 17, 185–202. <http://dx.doi.org/10.1016/j.concog.2007.01.007>.
- Goschke, T. (1998). Implicit learning of perceptual and motor sequences: Evidence for independent learning systems. In M. A. Stadler & P. A. Frensch (Eds.), *Handbook of implicit learning* (pp. 401–444). Thousand Oaks, CA: Sage Publications.
- Higham, P. A., Vokey, J. R., & Pritchard, J. (2000). Beyond dissociation logic: Evidence for controlled and automatic influences in artificial grammar learning. *Journal of Experimental Psychology: General*, 129(4), 457–470. <http://dx.doi.org/10.1037//0096-3445.129.4.457>.
- Jacoby, L. L. (1991). A process dissociation framework: Separating automatic from intentional uses of memory. *Journal of Memory and Language*, 30(5), 513–541. [http://dx.doi.org/10.1016/0749-596X\(91\)90025-F](http://dx.doi.org/10.1016/0749-596X(91)90025-F).
- Jacoby, L. L., Toth, J. P., & Yonelinas, A. P. (1993). Separating conscious and unconscious influences of memory: Measuring recollection. *Journal of Experimental Psychology: General*, 122, 139. <http://dx.doi.org/10.1037//0096-3445.122.2.139>.
- Jiménez, L., Vaquero, J. M. M., & Lupiáñez, J. (2006). Qualitative differences between implicit and explicit sequence learning. *Journal of Experimental Psychology. Learning, Memory, and Cognition*, 32(3), 475–490. <http://dx.doi.org/10.1037/0278-7393.32.3.475>.
- Lau, H. C., & Passingham, R. E. (2007). Unconscious activation of the cognitive control system in the human prefrontal cortex. *The Journal of Neuroscience*, 27(21), 5805–5811. <http://dx.doi.org/10.1523/JNEUROSCI.4335-06.2007>.
- Mealor, A. D., Dienes, Z., & Scott, R. B. (2014). Unconscious sources of familiarity can be strategically excluded in support of conscious task demands. *Psychology of Consciousness: Theory, Research, and Practice*, 1(3), 229. <http://dx.doi.org/10.1037/cns0000027>.
- Nissen, M. J., & Bullemer, P. (1987). Attentional requirements of learning: Evidence from performance measures. *Cognitive Psychology*, 19, 1–32. [http://dx.doi.org/10.1016/0010-0285\(87\)90002-8](http://dx.doi.org/10.1016/0010-0285(87)90002-8).
- Norman, E., Price, M. C., Duff, S. C., & Mentzoni, R. A. (2007). Gradations of awareness in a modified sentence learning task. *Consciousness and Cognition*, 16, 809–837. <http://dx.doi.org/10.1016/j.concog.2007.02.004>.
- Norman, E., Price, M. C., & Jones, E. (2011). Measuring strategic control in artificial grammar learning. *Consciousness and Cognition*, 20, 1920–1929. <http://dx.doi.org/10.1016/j.concog.2011.07.008>.
- Norman, E., Scott, R. B., Price, M. C., Jones, E., & Dienes, Z. (2016). Can unconscious structural knowledge be strategically controlled? Manuscript submitted for publication.
- Pasquali, A., Timmermans, B., & Cleeremans, A. (2010). Know thyself: Metacognitive networks and measures of consciousness. *Cognition*, 117, 182–190. <http://dx.doi.org/10.1016/j.cognition.2010.08.010>.
- Reber, A. S. (1967). Implicit learning of artificial grammars. *Journal of Verbal Learning and Verbal Behavior*, 77, 317–327. [http://dx.doi.org/10.1016/S0022-5371\(67\)80149-X](http://dx.doi.org/10.1016/S0022-5371(67)80149-X).
- Reber, A. S. (1993). *Implicit learning and tacit knowledge: An essay on the cognitive unconscious*. NY: Oxford University Press.
- Sandberg, K., Timmermans, B., Overgaard, M., & Cleeremans, A. (2010). Measuring unconsciousness: Is one measure better than the other? *Consciousness and Cognition*, 19, 1069–1078. <http://dx.doi.org/10.1016/j.concog.2009.12.013>.
- Schmidt, J. R., Crump, M. J. C., Cheesman, J., & Besner, D. (2007). Contingency learning without awareness: Evidence for implicit control. *Consciousness and Cognition*, 16(2), 421–435. <http://dx.doi.org/10.1016/j.concog.2006.06.010>.
- Schneider, W., Eschman, A., & Zuccolotto, A. (2002a). *E-prime reference guide*. Pittsburgh, PA: Psychology Software Tools Inc.
- Schneider, W., Eschman, A., & Zuccolotto, A. (2002b). *E-prime user's guide*. Pittsburgh, PA: Psychology Software Tools Inc.
- Scott, R. B., & Dienes, Z. (2008). The conscious, the unconscious, and familiarity. *Journal of Experimental Psychology. Learning, Memory, and Cognition*, 34(5), 1264–1288. <http://dx.doi.org/10.1037/a0012943>.
- Scott, R., & Dienes, Z. (2010). The metacognitive role of familiarity in artificial grammar learning: Transitions from unconscious to conscious knowledge. In A. Efklides & P. Misailidi (Eds.), *Trends and prospects in metacognition research* (pp. 37–61). New York, NY: Springer.
- Van Gaal, S., & Lamme, V. A. (2012). Unconscious high-level information processing implication for neurobiological theories of consciousness. *The Neuroscientist*, 18(3), 287–301. <http://dx.doi.org/10.1177/1073858411404079>.
- Van Gaal, S., Ridderinkhof, K. R., Scholte, H. S., & Lamme, V. A. F. (2010). Unconscious activation of the prefrontal no-go network. *The Journal of Neuroscience*, 30(11), 4143–4150. <http://dx.doi.org/10.1523/JNEUROSCI.2992-09.2010>.
- Wan, L., Dienes, Z., & Fu, X. (2008). Intentional control based on familiarity in artificial grammar learning. *Consciousness and Cognition*, 17(4), 1209–1218. <http://dx.doi.org/10.1016/j.concog.2008.06.007>.
- Wilkinson, L., & Shanks, D. R. (2004). Intentional control and implicit sequence learning. *Journal of Experimental Psychology. Learning, Memory, and Cognition*, 30(2), 354–369. <http://dx.doi.org/10.1037/0278-7393.30.2.354>.
- Yu, J., & Bellezza, F. S. (2000). Process dissociation as source monitoring. *Journal of Experimental Psychology. Learning, Memory, and Cognition*, 26(6), 1518–1533. <http://dx.doi.org/10.1037//0278-7393.26.6.1518>.