

Conjugated Ynones in Organic Synthesis

Carmen Nájera,^a Leiv K. Sydnes^{b*} and Miguel Yus^a

^a*Centro de Innovación en Química Avanzada (ORFEO-CINQA), Universidad de Alicante, Apdo. 99,*

E-03080 Alicante, Spain

^b*Department of Chemistry, University of Bergen, Allégt. 41, NO-5007 Bergen, Norway*

ABSTRACT: This review article will consider the preparation and application of ynones in synthetic organic chemistry. Concerning the preparation of these bifunctional compounds, several methodologies starting from propargyl alcohols, acyl derivatives – both by using alkynylmetal reagents or by transition metal (mainly palladium and copper) catalyzed alkynylations–, carbon monoxide (carbonylation of terminal alkynes and alkenes) and other substrates will be discussed. The reactivity and synthetic applications of ynones will be focused on conjugate additions with boron-, carbon-, nitrogen-, oxygen- and other heteroatom-containing nucleophiles, as well as radicals. Then, cycloaddition processes will include [2+2] cycloadditions, [3+2] 1,3-dipolar cycloadditions (with azides, nitrones, azomethine imines and ylides, nitrile oxides, diazo compounds and other dipoles), and [4+2] cycloadditions (mainly Diels-Alder-type reactions). The reduction of the triple bond, addition to the carbonyl group (using carbon- and hetero-nucleophiles, and reductions), and other not so commonly used processes (such as aldol reactions, cyclizations and isomerizations) will be considered at the end.

CONTENTS

1. Introduction
2. Preparations of Ynones
 - 2.1. From Propargylic Alcohols
 - 2.1.1. Chromium Oxidants
 - 2.1.2. Manganese Dioxide
 - 2.1.3. Swern Oxidation
 - 2.1.4. Hypervalent Iodine Compounds
 - 2.1.5. Other Oxidants
 - 2.2. From Acyl Derivatives
 - 2.2.1. Acylation of Alkynylmetal Reagents
 - 2.2.1.1. Weinreb and Other Amides
 - 2.2.1.2. Ester Derivatives

- 2.2.1.3. Acyl Chlorides and Anhydrides
- 2.2.1.4. Nitriles
- 2.2.2. Metal-Catalyzed Alkynylation of Acid Derivatives
 - 2.2.2.1. Palladium- and Copper-Catalyzed Acylation of Terminal Alkynes
 - 2.2.2.2. Palladium-Catalyzed Copper-Free Acylation of Terminal Alkynes
 - 2.2.2.3. Copper-Catalyzed Acylation of Terminal Alkynes
 - 2.2.2.4. Copper-Catalyzed Acylation of Alkynylmetals
 - 2.2.2.5. Other Acylations of Terminal Alkynes
- 2.3. From Carbon Monoxide
 - 2.3.1. Palladium- and Copper-Catalyzed Carbonylation of Terminal Alkynes
 - 2.3.2. Palladium-Catalyzed Carbonylation of Terminal Alkynes
 - 2.3.3. Other Carbonylation Reactions
- 2.4. From Other Substrates
 - 2.4.1. From Aldehydes
 - 2.4.2. From Propiolic Acid Derivatives
 - 2.4.3. From α -Keto Acids
 - 2.4.4. From Propargylic Esters
 - 2.4.5. From Aryl Iodides
- 3. Transformations of Ynones
 - 3.1. Conjugate Additions
 - 3.1.1. Boron Nucleophiles
 - 3.1.2. Carbon Nucleophiles
 - 3.1.2.1. Organometallic Reagents
 - 3.1.2.2. Metal Catalysis
 - 3.1.2.3. Non-Metallic Catalysis
 - 3.1.2.4. Enolates and Related Carbanions
 - 3.1.2.5. Enols and Other Neutral Nucleophiles
 - 3.1.3. Heteronucleophiles
 - 3.1.3.1. Nitrogen Nucleophiles
 - 3.1.3.1.1. Intramolecular Hydroamination
 - 3.1.3.1.2. Intermolecular Hydroamination
 - 3.1.3.1.3. Reactions with Dinucleophiles
 - 3.1.3.2. Oxygen Nucleophiles

- 3.1.3.2.1. Intramolecular Reactions
 - 3.1.3.2.2. Intermolecular Reactions
 - 3.1.3.3. Other Nucleophiles
 - 3.1.3.3.1. Silicon
 - 3.1.3.3.2. Phosphorous
 - 3.1.3.3.3. Sulfur, Selenium and Tellurium
 - 3.1.3.3.4. Chloride and Iodide
 - 3.1.3.3.5. Tin
 - 3.1.4. Radical Additions
 - 3.1.4.1. Via Radical-Induced Bond Formation
 - 3.1.4.2. Via Ynone Radical Anions
- 3.2. Cycloaddition Reactions
 - 3.2.1. [2+2] Cycloadditions
 - 3.2.2. [3+2] 1,3-Dipolar Cycloadditions
 - 3.2.2.1. Azides
 - 3.2.2.2. Nitrones
 - 3.2.2.3. Azomethine Imines
 - 3.2.2.4. Azomethine Ylides
 - 3.2.2.5. Nitrile Oxides
 - 3.2.2.6. Diazo Compounds
 - 3.2.2.7. Other Annulations
 - 3.2.3. [4+2] Cycloadditions
 - 3.2.4. Other Cyclizations
 - 3.2.4.1. Carbocyclizations
 - 3.2.4.2. Heterocyclizations
 - 3.2.4.2.1. Nitrogen-Containing Heterocycles
 - 3.2.4.2.2. Oxygen-Containing Heterocycles
- 3.3. Reduction of the Triple Bond
- 3.4. Addition to the Carbonyl Group
 - 3.4.1. Carbon Nucleophiles
 - 3.4.2. Heteronucleophiles
 - 3.4.3. Reductions
 - 3.4.3.1. Boron Reagents
 - 3.4.3.2. Hydrogen Transfer
 - 3.4.3.3. Other Reagents

3.5. Other Reactions

3.5.1. Aldol Reactions

3.5.2. Cyclizations

3.5.3. Isomerizations

3.5.4. Other Processes

4. Conclusions

Author Information

Corresponding Authors

Notes

Biographies

Acknowledgments

Abbreviations

References

1. INTRODUCTION

Two functionalities in close proximity in the same molecule generally induces new reactivity due to interaction(s) between the functional groups. This is the case with conjugated ynones, also denoted α,β -ynones, where a carbonyl group is adjacent to a carbon-carbon triple bond, and the resulting interactions provoke reactions different from those exhibited by the individual functional groups. This review article will consider the chemistry of α,β -ynones, paying special attention to their synthetic applications. Before 2000 very few reports on this topic have appeared, so this article will focus on literature published after that year, but taking into consideration that the field has been partially covered in several review articles concerning the preparation¹⁻³ or reactivity⁴⁻¹¹ of α,β -acetylenic carbonyl compounds. Here we will cover all methodologies involving all aspects of conjugated ynones until the end of 2018.

2. PREPARATIONS OF YNONES

In this Section the synthesis of ynones by oxidation methods of propargyl alcohols, by acylation of terminal alkynes and by the three-component Pd-catalyzed reaction involving carbon monoxide will be considered. Other substrates such as aldehydes, propiolic acid derivatives or α -keto acids can be also alkynylated using new methodologies. In addition, the ring opening of cyclopropanes will be treated.

2.1. From Propargylic Alcohols

Propargyl alcohols are usually prepared by reaction of metalated alkynes with aldehydes or by Sonogashira arylation of alkynols. Their oxidation can be performed with different types of reagents which are considered in the following Sections.

2.1.1. Chromium Oxidants. The oxidation of propargyl alcohols with chromium(VI) reagents was initially performed with CrO_3 ¹²⁻¹⁴ and with pyridinium dichromate (PDC) for the synthesis of 25-hydroxy vitamin D₂.¹⁵ Recently ynone **3**, an intermediate in the synthesis of the natural product xanthofulvin (a promising lead for the spinal cord regeneration) has been achieved using PDC (Scheme 1).¹⁶ Iodochromone **1** was cross-coupled with 3-butyn-2-ol under typical Sonogashira Pd-conditions giving alcohol **2** which after subsequent oxidation with PDC afforded ynone **3**.

Scheme 1. Oxidation of Propargyl Alcohol 2 with PDC

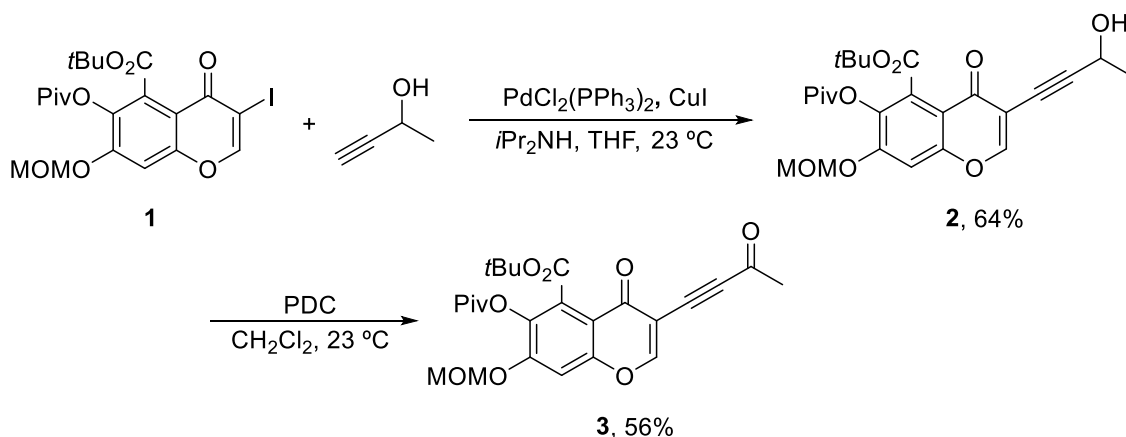

Pyridinium chlorochromate (PCC) has been widely used in several cases. For instance, propargyl alcohols **4** have been oxidized to the corresponding ynone **5** in moderated yields, these products being precursors for sulfonylbuta-1,3-diyne by treatment with $(\text{CF}_3\text{SO}_2)_2\text{O}$ and the Hünig base (Scheme 2).¹⁷

Scheme 2. Oxidation of Propargyl Alcohols 4 with PCC

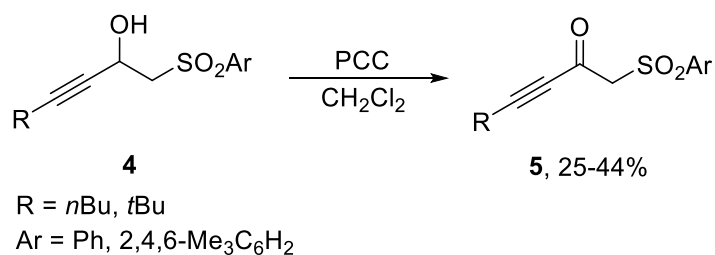

During the total synthesis of the furanosesquiterpenes crassifolone and dihydrocrassifolone, propargyl alcohol **6** was transformed into ynone **7** using PCC at 18 °C in dichloromethane in excellent yield (Scheme 3).¹⁸

Scheme 3. Oxidation of Propargyl Alcohol 6 with PCC

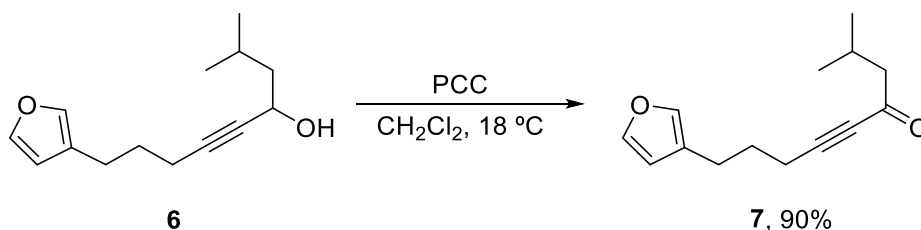

Cossy and co-workers have performed the synthesis of α,β -epoxy and α,β -aziridinyl ynones **9** by oxidation of the corresponding alcohol **8** with PCC (Scheme 4).¹⁹ The oxidation was carried out in the presence of NaOAc and molecular sieves in dichloromethane and at room temperature, and the expected ynones **9** were obtained in moderated to good yields.

Scheme 4. Oxidation of Alcohols **8** with PCC to Ynones **9**

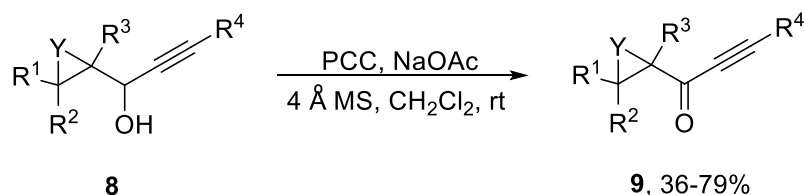

Y = O, NTs

R¹ = PMBOCH₂, BnOCH₂CHMe, TBSOCH₂CHMe, HOCH₂CHMe

R² = H, PMBOCH₂, BnOCH₂CHMe

R³ = H, Me

R⁴ = TIPS, *n*Pr, TrOCH₂

2-Alkynyloxy aryl aldehydes **11** have been synthesized by oxidation of propargylic alcohols **10** (easily prepared by Sonogashira coupling of *o*-bromobenzaldehydes and propargyl alcohols) with PCC (Scheme 5).²⁰ Ynones **11** (R² = aryl) are precursors of isoindolines by reaction with primary amines, these compounds being present in several bioactive compounds.

Scheme 5. Synthesis of Ynones **11** by Oxidation of **10** with PCC

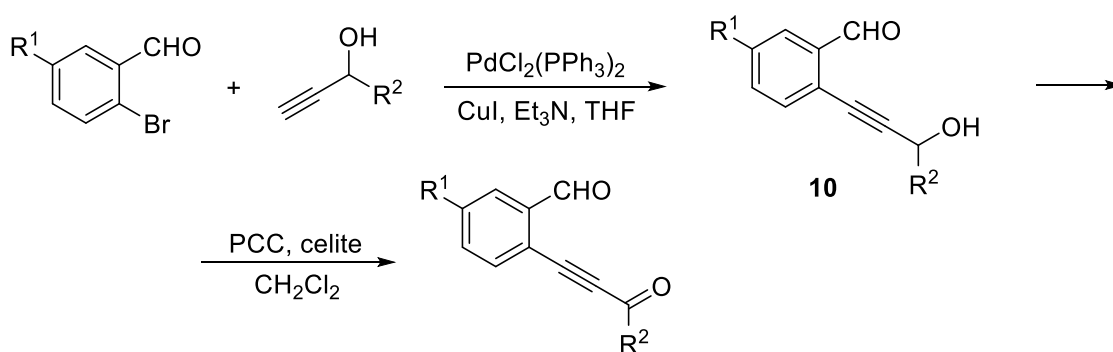

R¹ = H, F, Cl, MeO

R² = Me, Ph, 4-MeOC₆H₄, 4-BrC₆H₄

2.1.2. Manganese Dioxide. Manganese dioxide is a mild oxidant for allylic and propargylic alcohols in different solvents and also in ionic liquids.²¹ Okamura and co-workers described in 1985 the oxidation of a β -ionone-derived propargylic alcohol with an excess of freshly activated MnO_2 in CCl_4 .²² Studies toward the synthesis of the F and G rings of the azaspiracid natural products involved the preparation of ynone **13** by reaction of the lithium acetylide derived from compound **12** with acetaldehyde followed by MnO_2 oxidation (Scheme 6).²³ The same group performed the synthesis of a hapten, used as immunogens to generate antibodies to the toxic azaspiracids, from ynone **15** which was prepared by oxidation of alcohol **14** (Scheme 6).²⁴

Scheme 6. Synthesis of Ynones 13 and 15 from Alcohols 12 and 14

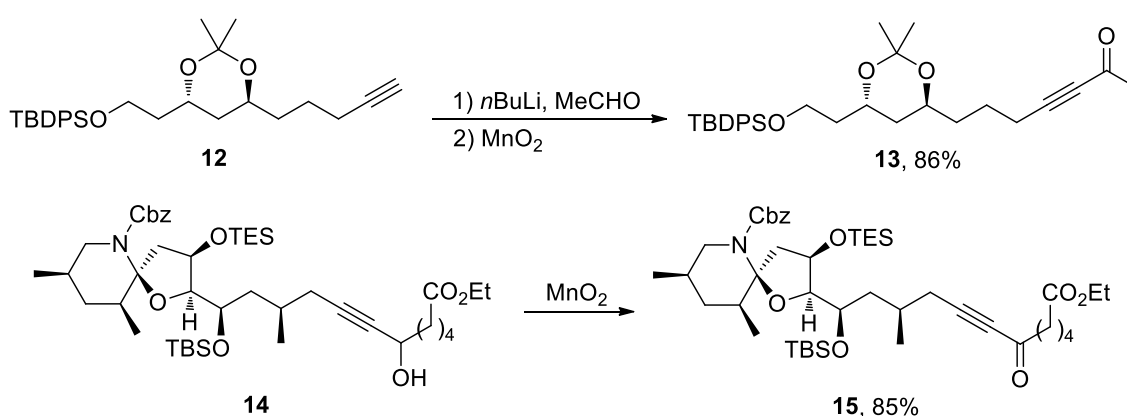

For asymmetric reduction studies of 4-(triisopropylsilyl)-3-butyn-2-one, Marshall and co-workers prepared ynone **16** in 94% yield by oxidation of the corresponding alcohol with MnO_2 in dichloromethane at room temperature (Figure 1).²⁵ In the enantioselective synthesis of dadospolides B, C, and D, Xing and O'Doherty transformed 1-nonyne into ynone **17**²⁶ by deprotonation with $n\text{BuLi}$, reaction with acetaldehyde, and final oxidation with MnO_2 in 86% yield (Figure 1). *o*-Haloaryl acetylenic ketones **18**²⁷ have been prepared from the corresponding *o*-haloaldehydes by reaction with lithium acetylides followed by treatment with MnO_2 at room temperature in moderate to good yields (Figure 1). Ynones **18** have been applied to the synthesis of 4-quinolones by a Pd-catalyzed amination reaction.²⁷ Novel ynone potassium trifluoroborates **19**²⁸ have been prepared by oxidation of the corresponding alcohols with MnO_2 in acetone at room temperature with yields ranging between 60 and 93% (Figure 1). These ynones were subsequently transformed into pyrazole potassium trifluoroborates by reaction with hydrazines (see Section 3.1.3.1.3), which can be further submitted to Pd-catalyzed cross-coupling reactions. For the synthesis of orris odorants, ynones **20**²⁹ have been used as synthetic intermediates which were prepared by oxidation of the precursors, propargylic alcohols with MnO_2 in 78-90% yields (Figure 1). Cossy and co-workers prepared the enynone **21**¹⁹ by MnO_2 oxidation of the corresponding alcohol in 83% yield (Figure 1). Marinelli and co-workers have prepared β -(2-aminophenyl)- α,β -ynones **22** by Sonogashira alkylation of *o*-iodoanilines with propargyl alcohols in 60-97% yields followed by

oxidation with MnO_2 in chloroform at $60\text{ }^\circ\text{C}$ in 49-81% yields³⁰ (Figure 1). These ynones have been transformed into 4-nitro and 4-sulfonyl quinolines by sequential addition of nitrite and sulfinate anions and subsequent annulation (see Schemes 168 and 223, respectively). When DMF/NaOH was used, 4-(dimethylamino)quinolines were formed.

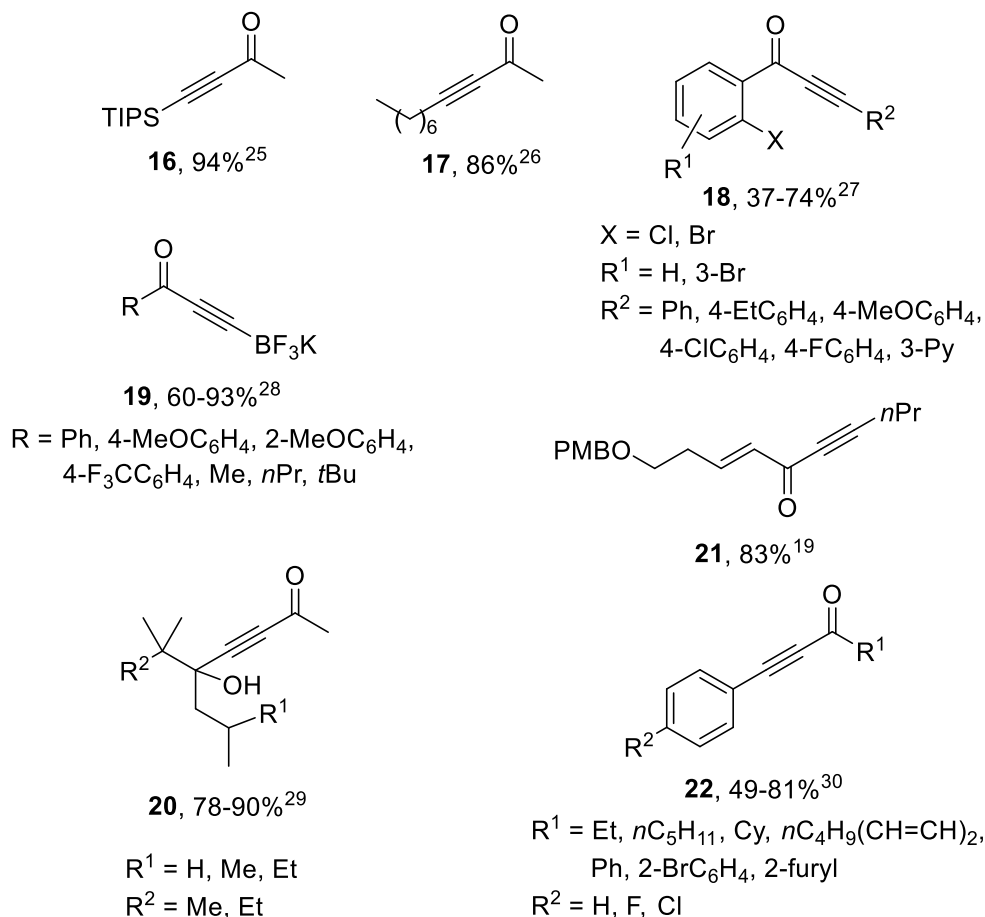
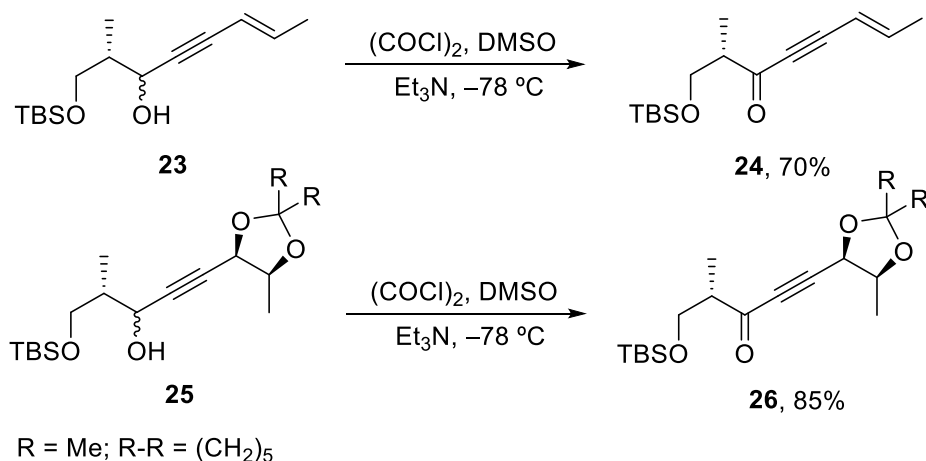

Figure 1. Ynones prepared by oxidation of propargyl alcohols with MnO_2 .

2.1.3. Swern Oxidation. Boger and co-workers applied the Swern oxidation of propargyl alcohols to form the corresponding ynones which were obtained in high yields (86-95%).³¹ One of these ynones was used as intermediate in the total synthesis of the rubrolone aglycon. The side chain of several pumiliotoxins has been prepared by using ynone **24** which was obtained by performing Swern oxidation of alcohol **23** (Scheme 7).³² Alternatively, ynones **26** have been also used in another route starting from the alcohol **25**.

Scheme 7. Swern Oxidation of Propargyl Alcohols **23** and **25**



Shapland and Thomas studied the preparation of precursors of phomactins performing the synthesis of several intermediate yrones by oxidation of the corresponding alcohols.³³ For instance, compounds **27** were submitted to the Swern oxidation giving the expected yrones **28** (Scheme 8).

Scheme 8. Swern Oxidation of Propargyl Alcohols **27**

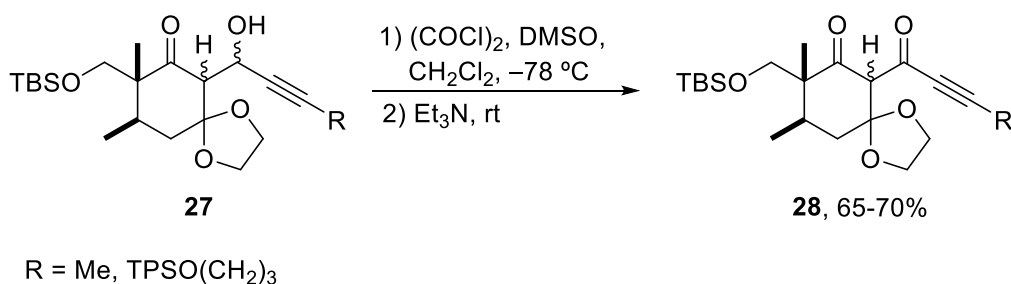

During the preparation of substituted tetrahydroanthrones different propargyl alcohols were transformed into yrones by Swern oxidation.³⁴ For instance, double oxidation took place when alcohols **29** were oxidized under typical Swern conditions giving yrones **30** in variable yields (Scheme 9). The yrones were further transformed into the related tetrahydroanthrones by a DMPA-catalyzed tandem nucleophilic addition process.

Scheme 9. Swern Oxidation of Propargyl Alcohols **29**

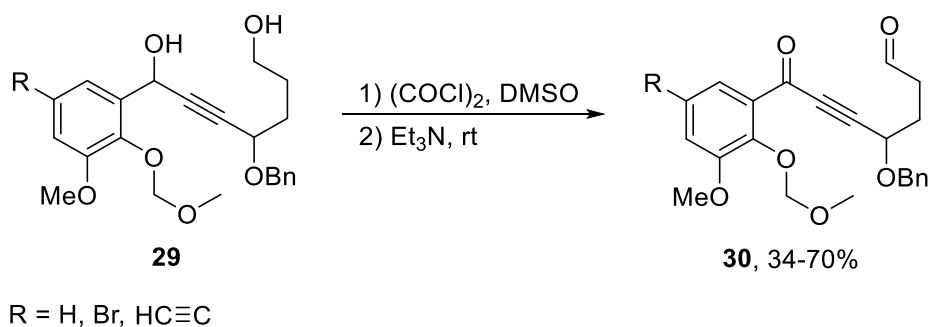

De Lera and co-workers have prepared ynone **32** from alcohol **31** using the Swern technology (Scheme 10).³⁵ This ynone is a precursor of peyssonenynes, marine natural products which are DNA methyl transferase inhibitors.

Scheme 10. Swern Oxidation of Propargylic Alcohol **31**

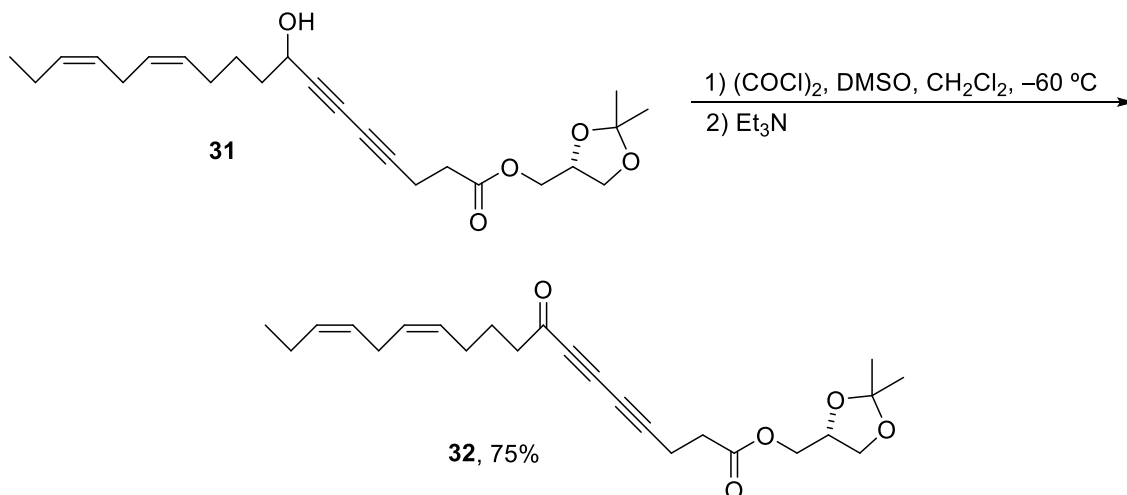

Pentynones and hexynones **34** have been prepared by a Swern oxidation of the corresponding alcohols **33** (Scheme 11).³⁶ In some cases better yields have been obtained using MnO_2 . These non-conjugated ynone have been used for the synthesis of furan and pyran derivatives by intramolecular anionic cyclizations.

Scheme 11. Swern Oxidation of Alkynols **33**

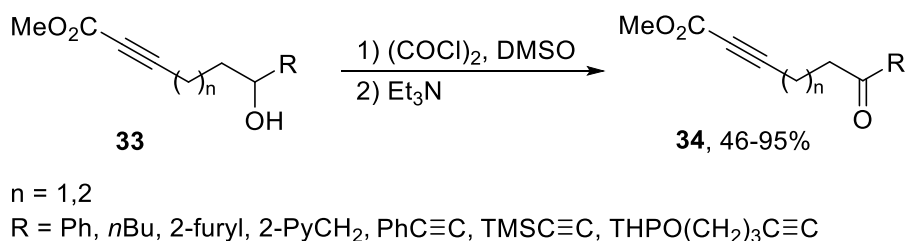

In all cases shown above, oxalyl chloride and DMSO were used as reagents for the generation of the dimethylalkoxysulfonium salts. As an alternative, the reagent 2,4,6-trichloro-1,3,5-triazine (cyanuric chloride, TCT) has been successfully used to activate DMSO under safer and more efficient reaction conditions than oxalyl chloride.³⁷ Different primary and secondary alcohols have been efficiently oxidized to the corresponding carbonyl compounds. As an example, alcohol **35** was transformed into ynone **36** using THF at $-30\text{ }^\circ\text{C}$ (Scheme 12).

Scheme 12. Oxidation of Propargyl Alcohol **35** to Ynone **36** using TCT and DMSO

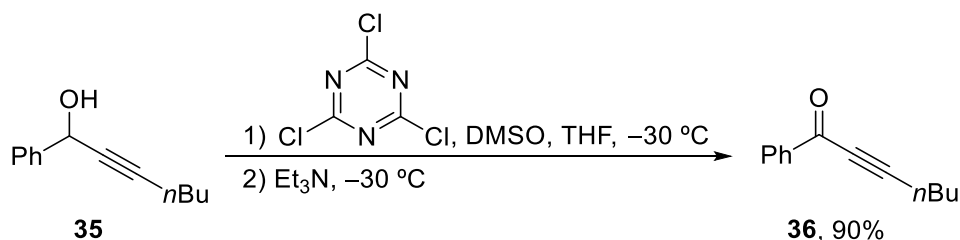

The oxidation of alcohols with DMSO using the sulfur trioxide-pyridine complex (Parikh–Doering oxidation)³⁸ has been applied to the synthesis of ynones. Kobayashi and co-workers prepared ynone **38** from a mixture of diastereomeric propargyl alcohols **37** in the synthesis of a fragment of phoslactomycin B (Scheme 13).³⁹ The same methodology was applied to the synthesis of ynone **40** from alcohol **39**.⁴⁰

Scheme 13. Oxidation of Alcohols **37 and **39** with DMSO and $\text{SO}_3\cdot\text{PyH}$ to Ynones **38** and **40****

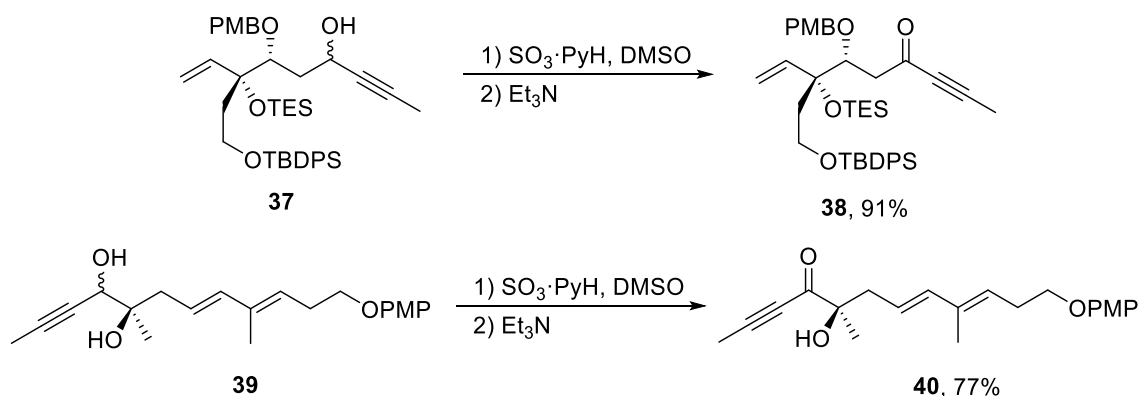

2.1.4. Hypervalent Iodine Compounds. 1,1,1-Tris(acetyloxy)-1,1-dihydro-1,2-benziodoxal-3-(1*H*)-one (the Dess–Martin periodane, DMP **41**)⁴¹ is a mild oxidant for the synthesis of aldehydes and ketones from alcohols. In the total synthesis of the 20-membered macrolide natural products (–)-lulimalide and figianolide B by Ghosh and Wang, alcohol **42** was oxidized to ynone **43** with DMP at room temperature (Scheme 14).⁴²

Scheme 14. Oxidation of Propargyl Alcohol **42 with DMP**

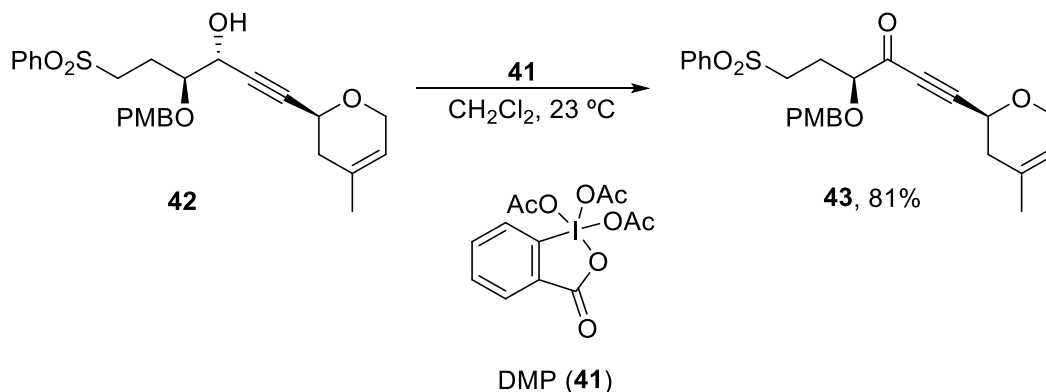

Ynone **44** has been prepared by Wender and co-workers as key intermediate in the asymmetric synthesis of the tricyclic core of the nerve growth factor-inducing cyathane diterpenes.⁴³ This ynone was synthesized by DMP oxidation of the precursor propargyl alcohol in 93% yield (Figure 2). Quesnelle and co-workers employed DMP or the Swern protocol for the synthesis of ynones **45**⁴⁴ from the corresponding propargyl alcohols in low yields. These ynones are suitable intermediates for the preparation of sordancin antifungal agents (Figure 2). Ley and co-workers studied the conjugate addition of propane-1,3-dithiol to ynones, ynoates and ynals affording the corresponding β -keto 1,3-dithianes, used for the synthesis of spiroketals.⁴⁴ For instance, ynone **46**,⁴⁶ prepared by oxidation of the corresponding alcohol with DMP, was used for the synthesis of the C16-C28 spiro ketal fragment of spongistatins. In the case of the ynone **47**,⁴⁷ the same methodology allowed the synthesis of the C1-C28 ABCD fragment of spongistatin 1. This strategy has been applied to bis-ynones **48**⁴⁸ synthesized by a Dess–Martin periodinane oxidation of the corresponding alcohols in 70–73% yield (Figure 2). In this case, the β,β' -bis-1,3-dithiane ketones were used as 1,3,5-triketone systems for the synthesis of polyketide natural products (see Section 3.1.3.3.3).

Olivo and co-workers have performed studies for the preparation of the auriside macrolactone. Ynone **49**⁴⁹ was one of the intermediates which was prepared by Dess–Martin oxidation of the precursor alcohol (Figure 2). Further, a formal synthesis of the auriside aglycon was carried out using ynone **50**⁵⁰ which was prepared from the corresponding propargyl alcohol by oxidation with DMP.

In the synthetic studies on anthrapyran antibiotics performed by Tietze and co-workers,^{51–53} for instance ynone **51**⁵³ was prepared in 98% yield by treatment of an alcohol with DMP (Figure 2) (see Scheme 189). By oxidation of the corresponding propargylic alcohol with DMP, McCluskey, Stewart and co-workers prepared ynone **52**⁵⁴ in 88% yield. This ynone has been cyclized to an anthrapyranone for biological studies. Pattenden and co-workers performed a radical-mediated Diels–Alder reaction with an iodo dienynone for the synthesis of a tricyclic ketone. This dienynone was prepared by oxidation of a bromo alcohol with DMP to give **53** in 82% yield, followed by treatment with NaI (Figure 2).⁵⁵

Jung and co-workers have performed the total synthesis of (–)- α -kainic acid using ynone **54**⁵⁶ which was obtained by oxidation of the corresponding propargyl alcohol with DMP (Figure 2). For the synthesis of the C3-C14 fragment of 7-deoxyokadaic acid by Forsyth and co-workers, the intermediate ynone **55**⁵⁷ (obtained by DMP oxidation of the precursor alcohol) was isolated in 81% (Figure 2).

As previously mentioned, Cossy and co-workers have studied the transfer hydrogenation of α,β -aziridinyl ynones **9**¹⁹ (Scheme 4), which have been prepared by PCC as well as DMP oxidation of alcohols **8**. Various 1,6- and 1,8-naphthalenophanes were prepared by photo-dehydro-Diels–Alder reaction of bis-ynones **56**⁵⁸ (Figure 2).

These ynones were obtained by DMP oxidation of the corresponding diols in 62-100% yield.

Tanaka and co-workers have performed the synthesis and biological evaluation as antimicrobials of kendomycin and its analogues. One of the intermediates is ynone **57**,⁵⁹ prepared by oxidation of a propargyl alcohol with DMP in 84% yield. The total synthesis of the natural products pectinolides A, C, D, and E has been performed by Sabitha and co-workers; in this case the ynone **58**⁶⁰ was prepared by DMP oxidation of the corresponding alcohol.

For the synthesis of the novel antimalarial pyranone crytorigidifoliol E by Krishna and co-workers a propargyl alcohol has been oxidized with DMP to give the ynone **59**⁶¹ in 90% yield (Figure 2).

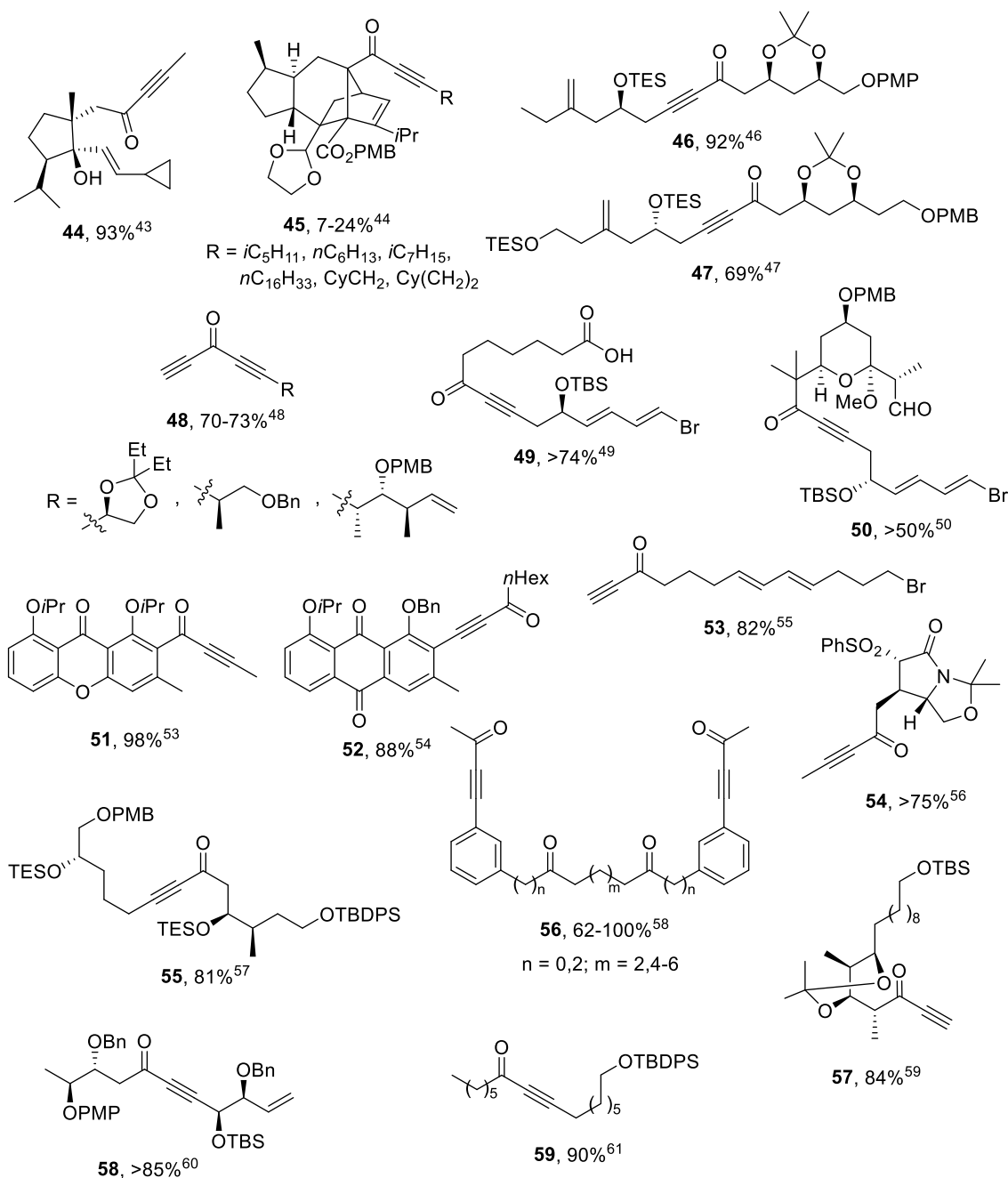

Figure 2. Selected ynones prepared by DMP oxidation of propargylic alcohols.

2-Iodoxybenzoic acid (IBX) is another useful commercially available hypervalent iodine compound which has been stabilized by benzoic and isophthalic acid to avoid explosions.⁶² Compared to DMP, IBX is more readily available and it is not moisture and air sensitive, being also easily recovered. The problem is the use of DMSO as solvent, but there are many examples using other solvents.

Baldwin and co-workers have used IBX in THF/DMSO for the oxidation of a propargyl alcohol affording ynones **60**⁶³ and **61**⁶⁴ in 87% yield (Figure 3). These ynones

have been used in the asymmetric synthesis of cytotoxic sponge metabolites (*R*)-strongyloidiols A and B and an analogue.

Tietze and co-workers have performed the total synthesis of anthrapyran metabolites isolated from marine-derived *Streptomyces* using an ynone as intermediate by oxidation of the corresponding propargylic alcohol with IBX (in dichloromethane/DMSO) instead of DMP, as in the case of ynone **51**⁵³ (Figure 2). Thus, the antiherpetic anthrapyran antibiotic AH-1763 IIa was prepared using ynone **62**⁵¹ in 97% yield (Figure 3). The anthrapyran metabolite γ -indomycinone has been prepared using the ynone **63**⁵² by oxidation with IBX of the corresponding alcohol in 93% yield (Figure 3). In the case of the total synthesis of the anthrapyran metabolite SS43405-e, the intermediate ynone **64**⁶⁵ was obtained with the same oxidant in 96% yield (Figure 3).

Brimble and co-workers have prepared ynones **65**⁶⁶ in 78-88% yields by oxidation of the precursor alcohols with IBX in DMSO (Figure 3). Ynones **65** have been applied as intermediates for the synthesis of 6,6-bisbenzannulated spirochete's related to the natural products rubromycins.⁶⁶ Moreover, ynone **66**⁶⁷ has been prepared by IBX oxidation in DMSO of the corresponding alcohol in 98% yield (Figure 3). This acetylenic ketone was an intermediate in the synthesis of the AB-ring fragment of (-)-gambierol performed by Sasaki and co-workers. In the previously described total synthesis of pectinolides D and E, Sabitha and co-workers used DMP for the synthesis of ynone **57**⁵⁹ (Figure 2). However, in the case of ynone **67**,⁶⁰ precursor of pectinolides A and C, the oxidation of the corresponding alcohol was performed with IBX in DMSO at 0 °C affording ketone **67** in 80% yield (Figure 3).

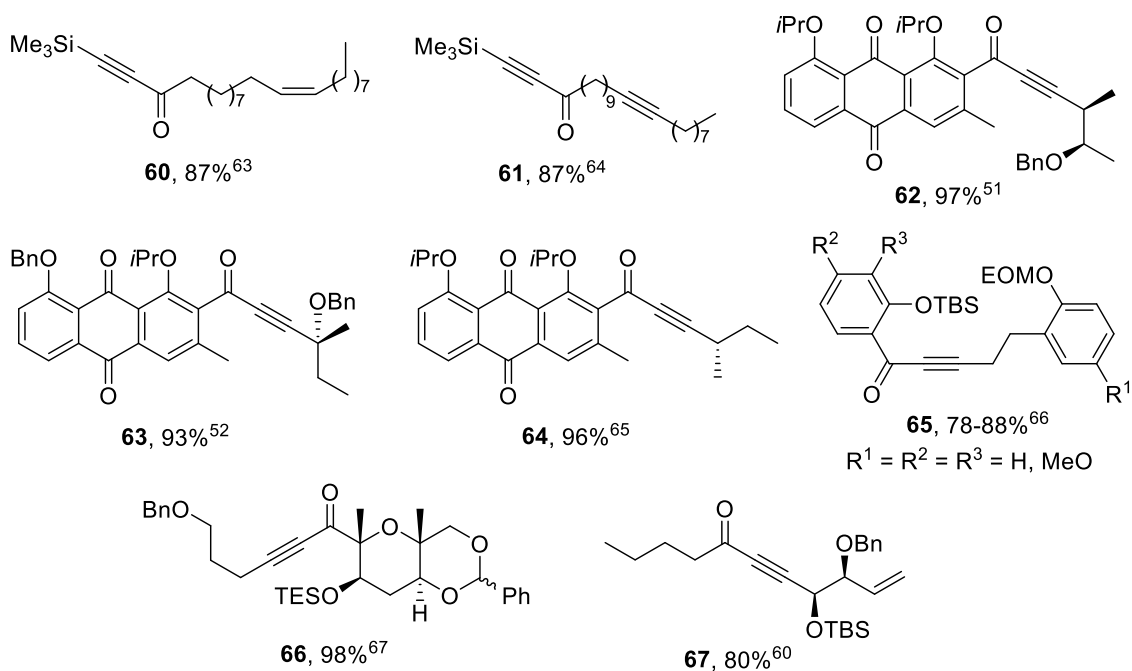
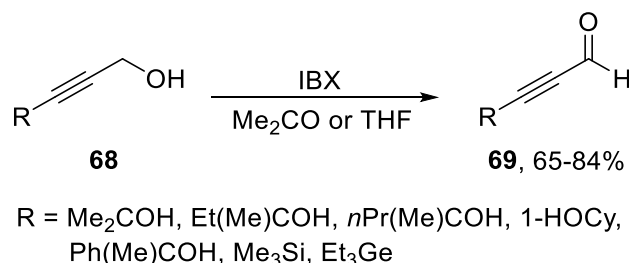

Figure 3. Selected ynones prepared by IBX oxidation of propargylic alcohols.

The application of IBX in THF or acetone made possible the oxidation of primary propargyl alcohols **68**⁶⁸ to the corresponding ynals **69** (Scheme 15).

Scheme 15. Synthesis of Ynals 69 by IBX Oxidation of Alcohols 68



2.1.5. Other Oxidants. Transition metal-catalyzed aerobic oxidation of propargyl alcohols to ynones avoids the use of stoichiometric amounts of the oxidant, using oxygen as the most readily available oxidant for chemical processes. This methodology has been applied with an oxovanadium complex [vanadium oxyacetylacetonate, VO(acac)₂] as catalyst by Uemura and co-workers^{69,70} under an oxygen atmosphere and in the presence of molecular sieves in acetonitrile at 80 °C (Scheme 16). In the case of aliphatic alcohols (**70**, R¹ = alkyl), higher yields of ynones **71** were obtained using VO(hfac)₂ as catalyst and hexafluoroacetylacetone (hfac) as additive (5 mol%). Calcium phosphate-vanadate apatite has also been employed as catalyst by the same group.⁷¹ Sain and co-workers have used cobalt(II) phthalocyanine for the aerobic oxidation of secondary alcohols under xylene reflux and with solid KOH.⁷² In the case of 1-octyn-3-ol the corresponding ynone was obtained in 70% yield.

Pedro and co-workers⁷³ reported that an *o*-phenylene-bis-(*N'*-methyloxamidate) cobalt(III) complex **72** was an efficient catalyst for the oxidation of propargyl alcohols **70** with molecular oxygen and pivalaldehyde (R¹ = alkyl, aryl; R = H, alkyl, aryl) in acetonitrile, giving **71** in good yields (60-93%) (Scheme 16).

Nitric oxide bearing traces of molecular oxygen has been used for the oxidation of propargyl alcohols to ynones in dry acetonitrile at 35 °C in 21-92% yields for alcohols bearing R² = aryl groups.⁷⁴ However, for aliphatic alcohols NO gave very poor results. *tert*-Butyl hydroperoxide (TBHP) and copper nanoparticles (NPs, 10 mol%) have been employed for the oxidation of propargylic alcohols **70** in dichloromethane at room temperature.⁷⁵ In the presence of bipyridine (10 mol%) as ligand the oxidation was accelerated significantly, leading to the corresponding ynones in very good yields (Scheme 16). Under air, also primary alcohols (**70**, R¹ = H) are oxidized to ynals at room temperature in 45-75% yield, whereas secondary alcohols needed to be kept at 80 °C in toluene to afford the expected ynones **71**, generally in 80-95% yields.

Scheme 16. Metal-Complex-Catalyzed Aerobic Oxidation of Propargyl Alcohols 70

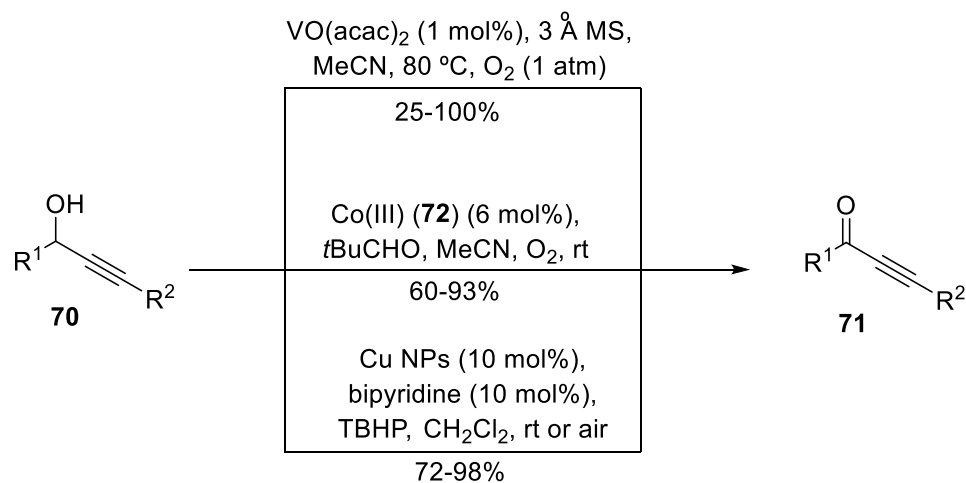

R¹ = Ph, 2-MeC₆H₄, 3-MeC₆H₄, 4-MeC₆H₄, 4-FC₆H₄, 2-ClC₆H₄, 3-ClC₆H₄, 4-ClC₆H₄,
2-MeOC₆H₄, 3-MeOC₆H₄, 4-MeOC₆H₄, 1-naphthyl, 2-naphthyl, 2-thienyl, *n*Pr, Cy,
*n*C₉H₁₉, (*E*)-PhCH=CH, PhC≡C, Me, *n*C₅H₁₁, 2-BrC₆H₄, 2-furyl, 2-HOC₆H₄,
2-HO-3-ClC₆H₃, *n*C₇H₁₅
R² = H, Me, Ph, Ph(CH₂)₂, *n*C₆H₁₃, *n*Bu

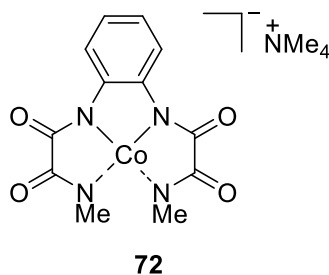

Oshima and co-workers have prepared ynals **69** by treatment of primary propargylic alcohols **68** with TiCl₄ and Et₃N in dichloromethane at 0 °C (Scheme 17).⁷⁶ This process is highly chemoselective because secondary propargylic alcohols as well as homo- and bishomopropargylic alcohols, were not oxidized to the corresponding ynones. A plausible mechanism, involving the formation of titanium alkoxide **73** which is attacked by Et₃N, has been proposed.

Scheme 17. Oxidation of Primary Alcohols 68 to Ynals 69 with TiCl₄/Et₃N

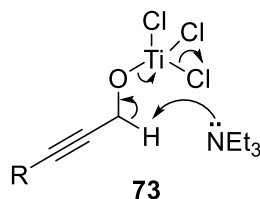
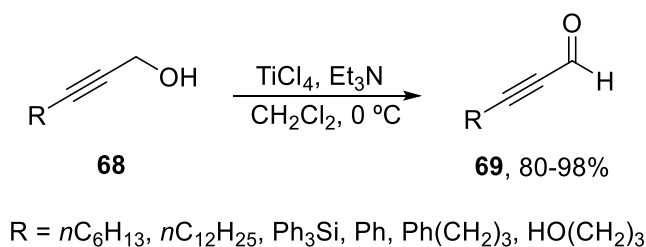

On the other hand, homopropargylic alcohols **74** were oxidized to ketones **75** with sodium periodate under chromium catalysis.⁷⁵ Sodium dichromate (1 mol%) in aqueous HNO₃ catalyzed the oxidation of primary and secondary homopropargylic alcohols with NaIO₄ in chloroform at 0 °C to give the corresponding ynals and ynones, respectively (Scheme 18).

Scheme 18. Oxidation of Homopropargylic Alcohols 74 with NaIO₄ Catalyzed by Na₂Cr₂O₇

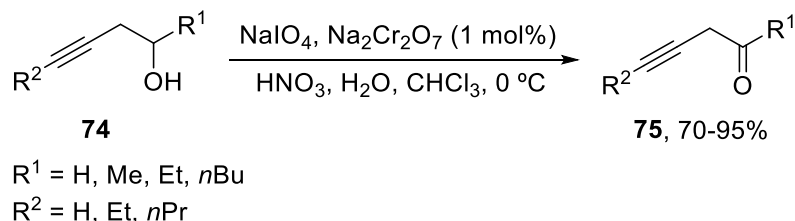

The oxidation of propargylic alcohols by molecular iodine has been carried out in the presence of potassium *tert*-butoxide in dichloromethane at 0 °C giving the expected ynones in 85-98% yield,⁷⁸ the real oxidant being the alkoxide. Recently, ynone **77** was prepared by oxidation of the sensitive alcohol **76** with 2,3-dichloro-5,6-dicyano-1,4-quinone (DDQ) in high yield (not reported) (Scheme 19).⁷⁹ This ynone, containing the azulene moiety, can be decomposed by a strong oxidant such as Cr(VI) or Mn(VII).

Scheme 19. Oxidation of the Propargylic Alcohol 76 with DDQ

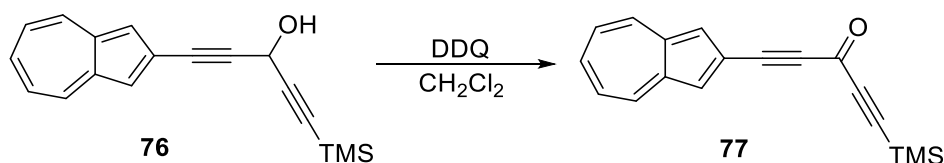

In conclusion, due to the easy availability of propargylic alcohols, their oxidation is a versatile strategy for the synthesis of ynones, hypervalent iodine compounds being the most widely used reagents under metal-free conditions.

2.2. From Acyl Derivatives

For the synthesis of the ynone skeleton, carbon-carbon forming reactions between the Csp from a terminal alkyne and the Csp² from an acyl derivative are the most used strategies. These processes can be carried out with different types of alkynylmetals and carboxylic-acid derivatives and by cross-coupling reactions of terminal alkynes under copper and/or palladium catalysis.

2.2.1. Acylation of Alkynylmetal Reagents. The use of alkynyl organometallic reagents represents a general method for the alkylation of acid derivatives under mild reaction conditions. This Section will consider the acylation of metalated alkynes with different types of acyl derivatives such as Weinreb and other amides, esters, lactones, metal carboxylates, acyl chlorides, anhydrides and nitriles.

2.2.1.1. Weinreb and Other Amides. The nucleophilic substitution of Weinreb amides with alkynylmetals is the most used methodology for their acylation. Preliminary reports from the Rapoport⁸⁰ and Baldwin⁸¹ groups used an excess (5 eq) of alkynyllithium in THF or alkynylmagnesium bromide in ether at -78 °C for the synthesis of ynones. Garcia and co-workers prepared 1-trimethylsilyl-1-alkyn-3-ones in 86-90% yield by reaction of Weinreb amides with lithium trimethylsilylacetylide (1-2 eq).⁸² Carter and Weldon used an alkynyllithium in the presence of CeCl₃ for the synthesis of an ynone intermediate of the C1-C12 fragment in the total synthesis studies of azaspiracid.⁸³ Haddad and co-workers⁸⁴ have alkynylated *N*-methoxy-*N*-methylchloroacetamide with (trimethylsilyl)ethynyllithium in toluene at -20 to 0 °C to give the corresponding ynone (93% yield), which is a precursor of a quinolone substructure of the protease inhibitor BILN2061. Roberts and co-workers have compared Weinreb amides with morpholine amides regarding their reactivity with alkynyllithiums in THF at 0 °C.⁸⁵ They concluded that the former gave the corresponding ynones with only 1 eq of alkynyllithium in quantitative yield, whereas the reaction with morpholine amides does not go to completion.

Koskinen and co-workers have prepared an intermediate ynone **3** for the synthesis of the spiroketal C16-C21 fragment **81** of calyculin C, a potent protein phosphatase inhibitor (Scheme 20).⁸⁶ Weinreb amide **78** reacted at -78 °C with alkynyllithium **79** (generated by deprotonation of the corresponding alkyne with *n*-BuLi) to give ynone **80**.

Scheme 20. Reaction of Weinreb Amide 78 with the Alkynyllithium 79

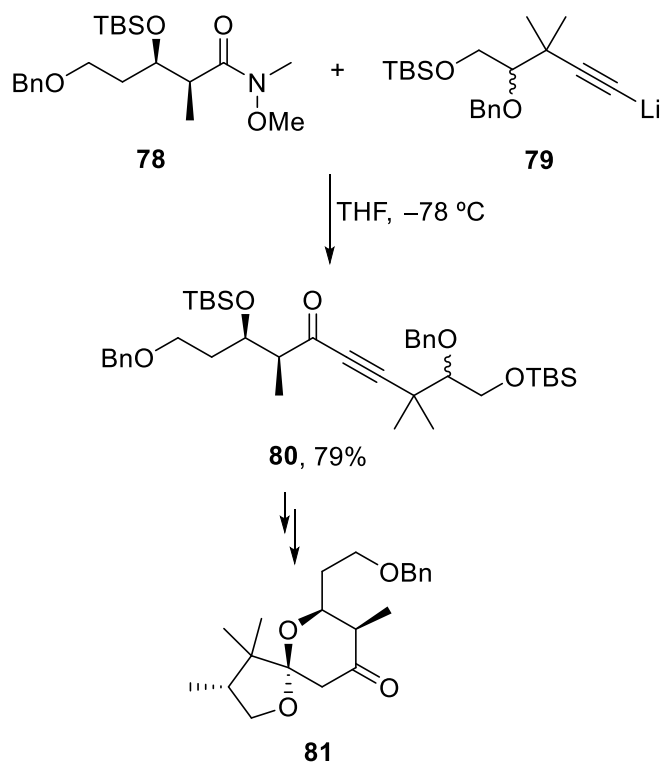

In the total synthesis of the antimetabolic marine natural product (+)-phomopsidin (**84**), Weinreb amide **82** was allowed to react with lithium (trimethylsilyl)acetylide at $0\text{ }^{\circ}\text{C}$ affording ynone **83** (yield not determined) (Scheme 21).⁸⁷

Scheme 21. Reaction of Weinreb Amide 82 with Lithium (Trimethylsilyl)acetylide

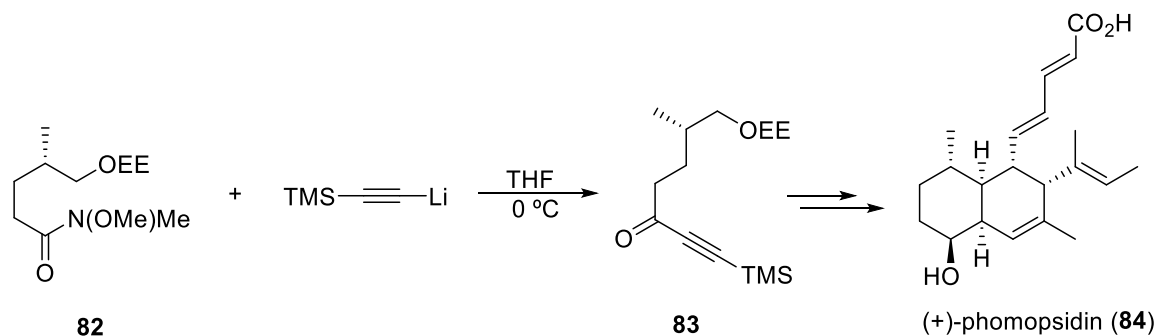

The coupling reaction of Weinreb amide **85** with alkynylmagnesium bromide **86** (prepared by deprotonation of the alkyne with EtMgBr) provided ynone **87** (Scheme 22).⁸⁸ This ynone is an intermediate in the synthesis of a macrolactin A analogue **88** carried out by Takemoto and co-workers.

Scheme 22. Reaction of Weinreb Amide 85 with Alkynylmagnesium Bromide 86

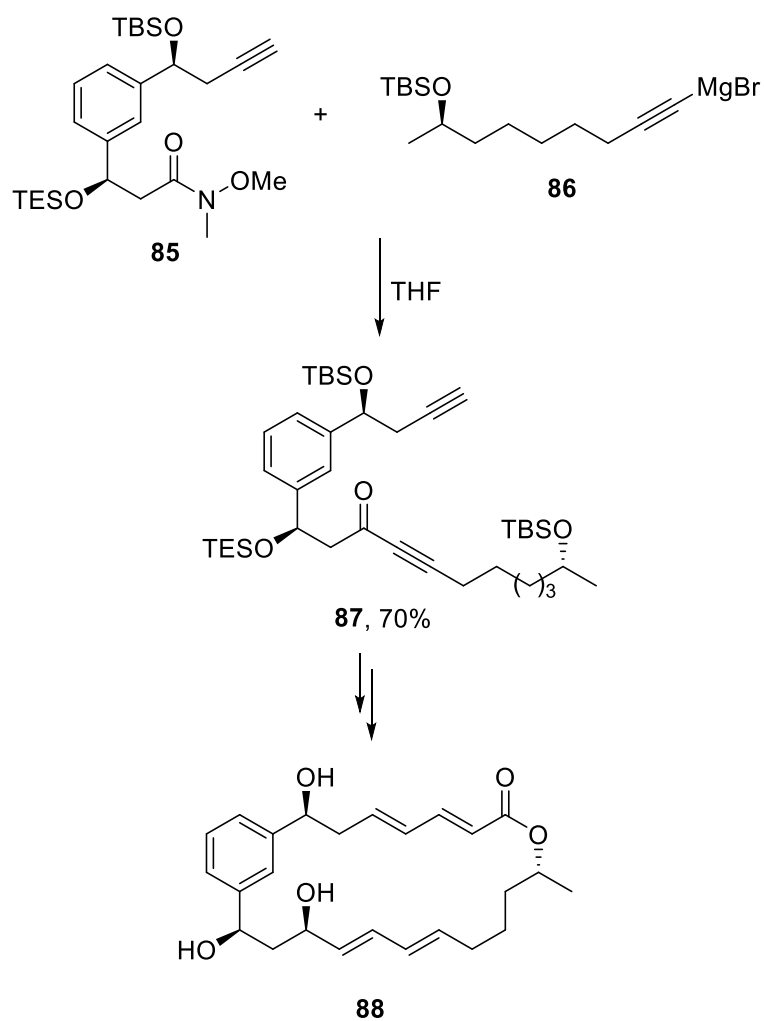

Amino acid-derived ynones **89-94**^{89,90} have been prepared by reaction of the corresponding Weinreb amides with alkynylmagnesium bromides (Figure 4). After deprotection of the Boc group the resulting ynones suffered intramolecular Michael addition to provide cyclic six-membered enaminones. A similar strategy has been used for the seven-membered enaminones.⁹⁰

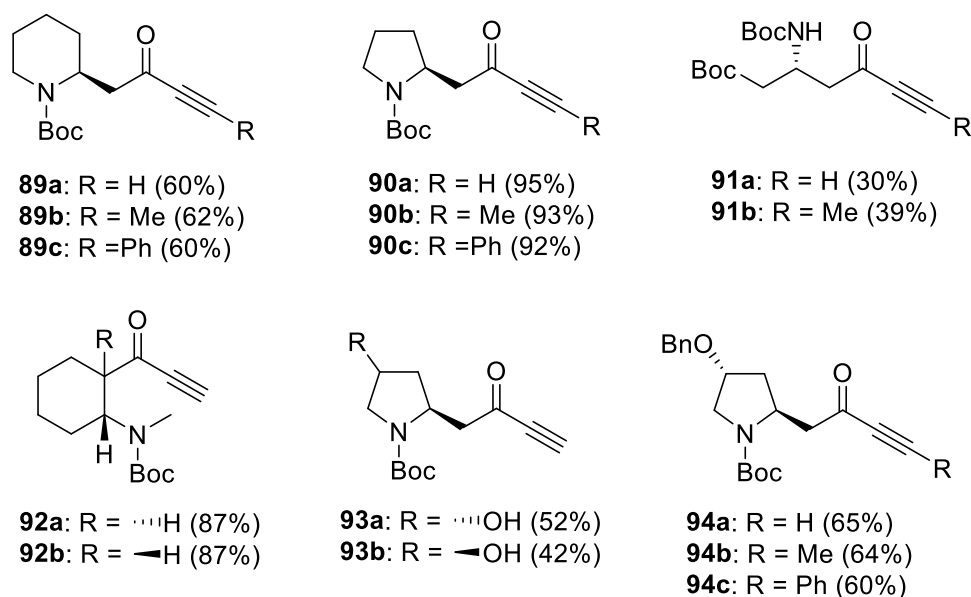
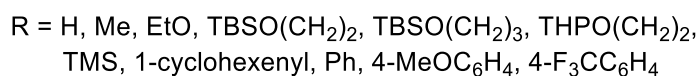
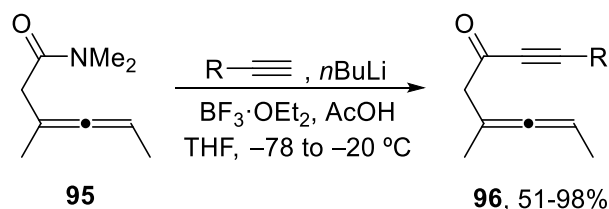

Figure 4. Ynone prepared by reaction of Weinreb amides with alkynylmagnesium bromides.

Allenylynyones **96**⁹¹ were prepared in good yields using Trost's methodology⁹² by reaction of amide **95** with alkynyllithium reagents in the presence of $\text{BF}_3 \cdot \text{OEt}_2$ (Scheme 23). These ynone **96** have been submitted to a Rh(I)-catalyzed carbocyclization affording trienic cyclohexanones.

Scheme 23. Reaction of Allenic Amides 95 with Alkynyllithium Reagents in the Presence of $\text{BF}_3 \cdot \text{OEt}_2$



For the synthesis of (*S*)-cyclopent-2-enol, Renaud and co-workers⁹³ prepared the ynone **97** from the corresponding Weinreb amide and 2-(trimethylsilyl)ethynyllithium in 95% yield (Figure 5). Chloronyones **98** have been obtained by reaction of the Weinreb amides with alkynyllithiums in THF at 0 °C (Figure 5; yields not provided).⁹⁴ Ynone **98** have been further transformed into 2-hydroxy-3,4-unsaturated disubstituted sulfilimines for haloamidation reactions. Quinolones have been easily prepared from ynone **99**⁹⁵ (Figure 5), which were synthesized by reaction of the corresponding Weinreb amides with alkynyllithium at 0 °C or alkynylmagnesium bromides at room temperature followed by quenching with aqueous HCl. Chiral α -amino ynone **100**, derived from α -amino acids, have been also cyclized to the corresponding substituted pyrrolidin-4-ones under gold-

catalysis.⁹⁶ These ynones have been prepared by treatment of the corresponding Weinreb amides with alkynyllithium reagents in good yields (52-89%; Figure 5). Synthetic studies by Curran and Sui on petrocortyne A, in order to determine the absolute configuration of the two alcohol stereocenters by Mosher's method, involved the preparation of ynone **101**⁹⁷ (Figure 5). This ynone was obtained in 89% yield by reaction of the precursor Weinreb amide with 2-(*tert*-butyldimethylsilyl)ethynyllithium in THF at $-78\text{ }^{\circ}\text{C}$. In the synthesis of a common tetrahydropyran subunit of the natural macrolides (–)-dactilolide and (–)-zampanolide, ynone **102**⁹⁸ has been used as intermediate (Figure 5). The precursor Weinreb amide was allowed to react with the Grignard reagent obtained by deprotonation of 4-benzyloxybut-1-yne with ethylmagnesium bromide giving ynone **102** in 60% yield. A related ynone **103**⁹⁹ (Figure 5) has been prepared in 74% yield using the same Weinreb amide and 2-phenylethynyllithium at $-78\text{ }^{\circ}\text{C}$ to room temperature. This ynone **103** has been used for the synthesis of the tetrahydropyranyl diarylheptanoid *ent*-diospongine A.⁹⁹ The Weinreb amide derived from 5-hexenoic acid was treated with lithium (trimethylsilyl)acetylide in THF at $-78\text{ }^{\circ}\text{C}$ to give the ynone **104**¹⁰⁰ in 91% yield (Figure 5), which is a precursor of tetracyclic ring systems.

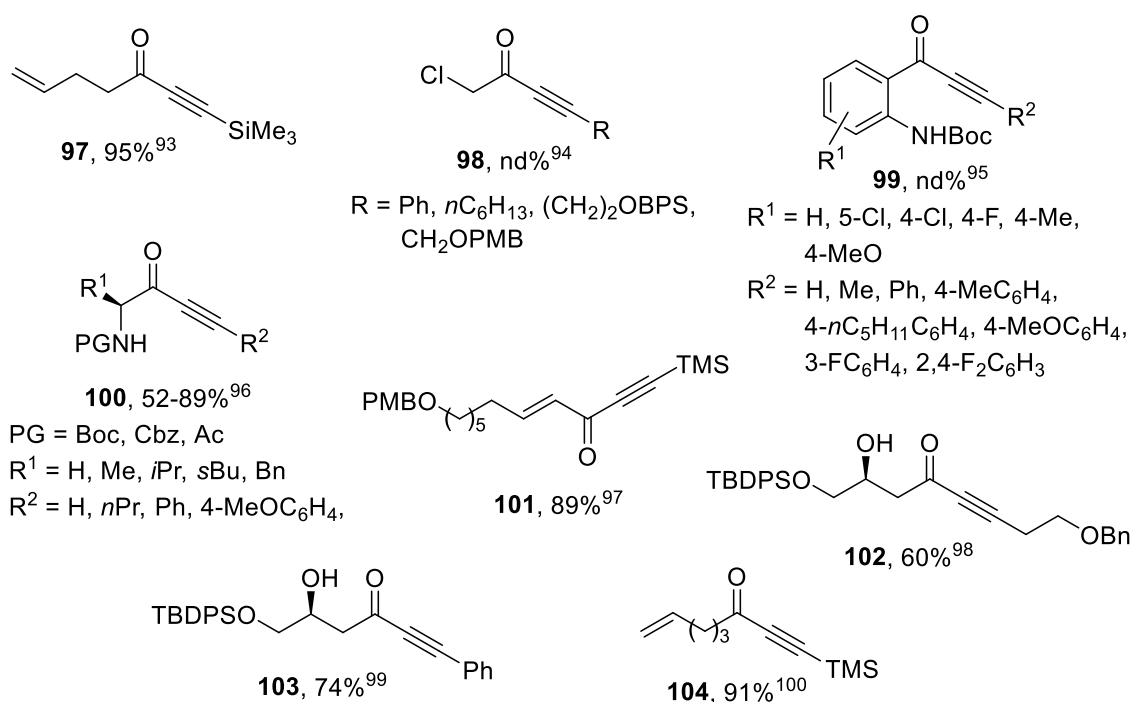
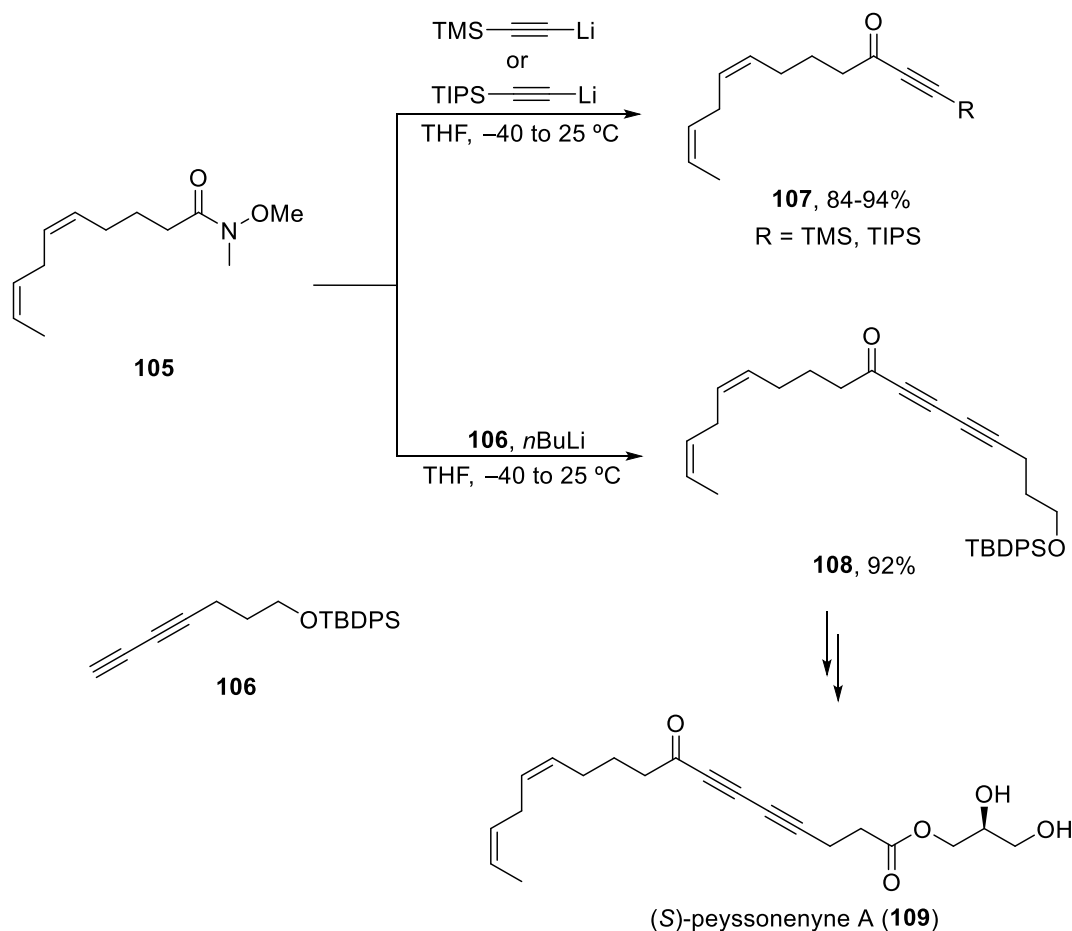

Figure 5. Selected ynones prepared by reaction of Weinreb amides with alkynyllithium reagents.

Synthetic approaches from de Lera and co-workers to the synthesis of natural marine compounds peyssonenyne have been performed using different ynones.¹⁰¹ In particular, ynones **107** and **108** have been prepared from the same Weinreb amide **105** using silylated lithium acetylides or the alkynyllithium intermediate derived from the diyne **106** (Scheme 24). Ynone **108** is the precursor of (*S*)-peyssonenyne A (**109**).

Scheme 24. Reaction of Weinreb Amide **105** with Different Alkynyllithium Reagents



Svete and co-workers have performed the synthesis of amino acids-derived ynones **100**¹⁰² (PG = Boc; $\text{R}^1 = \text{H, Me, } n\text{Bu}$; $\text{R}^2 = \text{H}$) (Figure 5) by reaction of the corresponding Weinreb amides with ethynylmagnesium bromide in THF at -78 °C to room temperature¹⁰³ for the synthesis of enaminone-based vinylogous peptides.

For the synthesis of marine sponges *Leucetta*-derived alkaloids spirocalcaridine A and B, Lovely and co-workers employed ynones **112** for the iodine-induced spirocyclization.¹⁰⁴ This ynone was prepared by reacting (4-methoxyphenyl)ethynyl-lithium derived from alkyne **111** with the Weinreb amide **110** (Scheme 25).

Scheme 25. Reaction of Weinreb Amide 108 with the Organolithium Reagent Derived from Alkyne 111

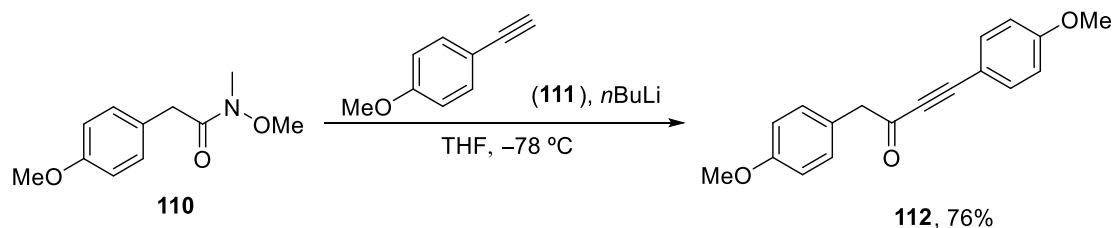

The synthesis of the guaiene sesquiterpene (–)-englerin A has been performed by López, Mascareñas and co-workers based on a Pt-catalyzed [4C+3C] cycloaddition of

allenedienes.¹⁰⁵ For the preparation of a key allenediene, diene-ynone **115** was prepared by reaction of Weinreb amide **113** with the lithium alkynylide derived from **114** (Scheme 26).

Scheme 26. Reaction of Weinreb Amide 113 with Alkynyllithium Reagent Derived from 114

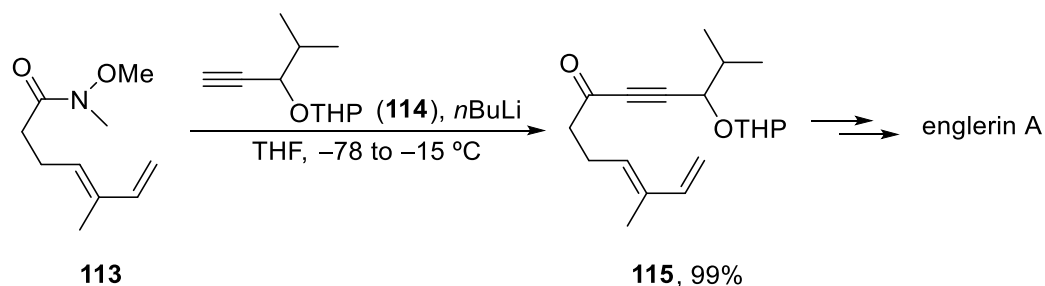

Renault and co-workers synthesized 3-substituted indolizidines by an intramolecular Michael addition of deprotected ynones **117**.¹⁰⁶ These ketones were prepared by reacting Weinreb amide **116** with ethynylmagnesium bromide giving **117a** in 82% yield (Scheme 27). In the case of ynones **117b-d**, alkynyllithium reagents were used for the alkylation in THF at -50 °C in good yields.

Scheme 27. Reaction of Weinreb Amide 116 with Alkynyl Metals

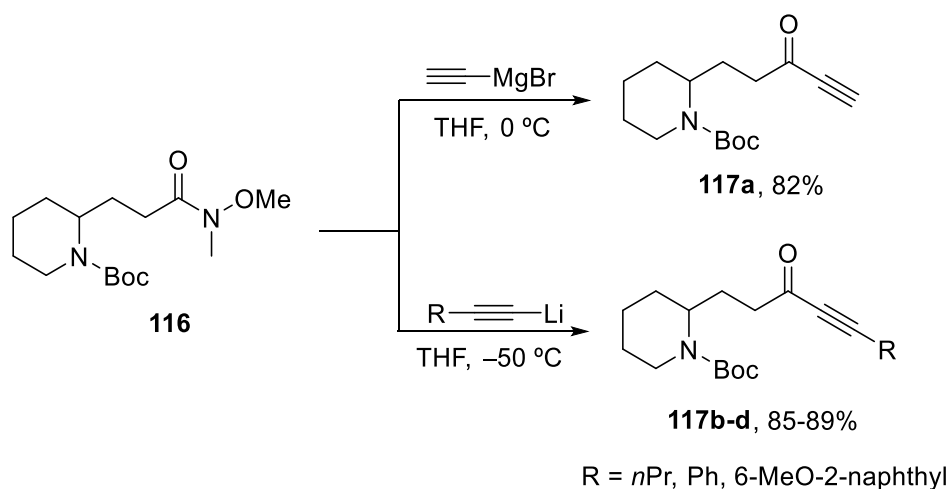

2.2.1.2. Ester Derivatives. For the alkylation of lactones, two strategies have been described: (a) the intermolecular reaction of an alkynylmetals with lactones,¹⁰⁷ which has been used in the preparation of spirofungin antibiotics¹⁰⁸ and in the synthesis of disaccharides,¹⁰⁹ and (b) the acyl transfer reaction of a propargyl ester to an organometallic reagent,¹¹⁰ which was employed in the synthesis of benzo[*h*]chromones.¹¹¹

Synthetic studies to access the okadaic-acid architecture by Forsyth and co-workers involved the reaction of lactones **118** with the alkynyllithium reagent derived from alkyne **119** affording ynones **120** after silylation in good yield (Scheme 28).¹¹²

Scheme 28. Reaction of Lactones 118 with Alkynyllithium Derived from 119

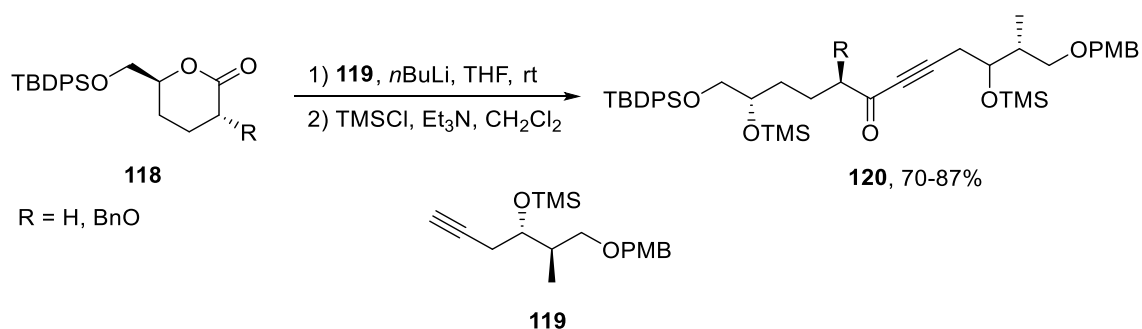

Wessig and co-workers have described the photo-dehydro-Diels–Alder reaction for the preparation of biaryls from ynones.¹¹³ In some examples Swern and DMP oxidations of propargylic alcohols (Section 2.1) were employed. For the synthesis of diynones **122**, diesters **121** were allowed to react with phenylethyneyllithium in the presence of $\text{BF}_3 \cdot \text{OEt}_2$ (Scheme 29).¹¹³

Scheme 29. Reaction of Diesters 121 with Phenylethyneyllithium in the Presence of $\text{BF}_3 \cdot \text{OEt}_2$

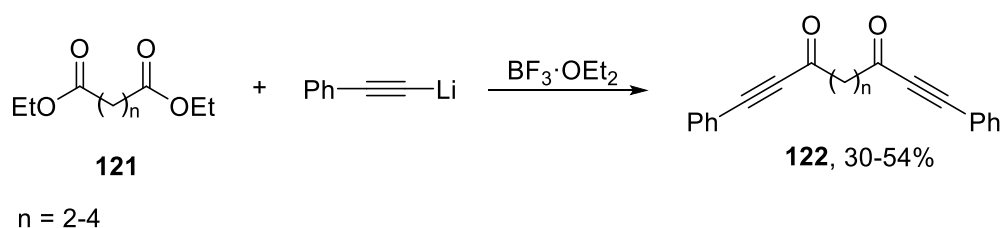

The synthesis of ynones from aliphatic ethyl esters has been carried out using terminal alkynes and potassium *tert*-butoxide as a base in THF and air at room temperature with moderate to good yields (33-76%).¹¹⁴ The presence of $\text{BF}_3 \cdot \text{OEt}_2$ was crucial for the alkylation of ethyl trifluoroacetate using an alkynyllithium derived from the alkyne **123** affording ynone **124** in good yield (Scheme 30).¹¹⁵ This ynone **124** has been used for the synthesis of the pyrazole herbicide fluazolate by reaction with hydrazine hydrate.

Scheme 30. Reaction of Ethyl Trifluoroacetate with the Alkynyllithium Derived from Alkyne 123

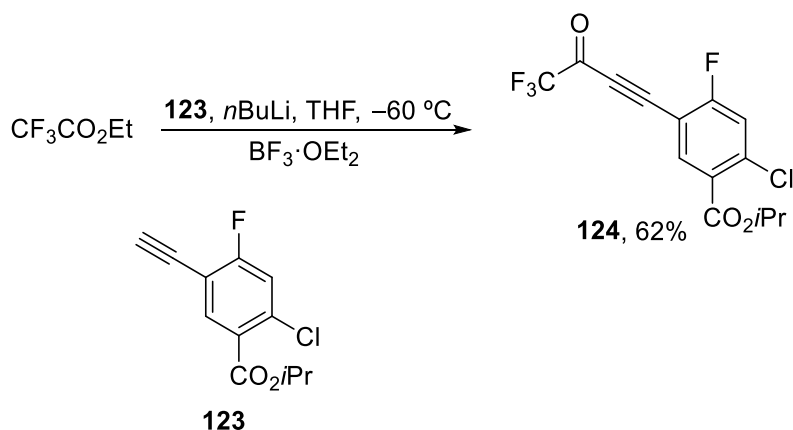

Aliphatic and aromatic activated esters such as benzotriazoate esters have shown higher reactivity in the reaction with lithium acetylides at $-78\text{ }^\circ\text{C}$ to room temperature giving the corresponding ynones in moderate to good yields (60-78%).¹¹⁶ This methodology has been applied to the synthesis of *D-erythro*-sphingosine using ynone **126**, which was prepared from the L-serine benzotriazole derivative **125** (Scheme 31).

Scheme 31. Reaction of Benzotriazole Ester **125** with a Lithium Acetylide

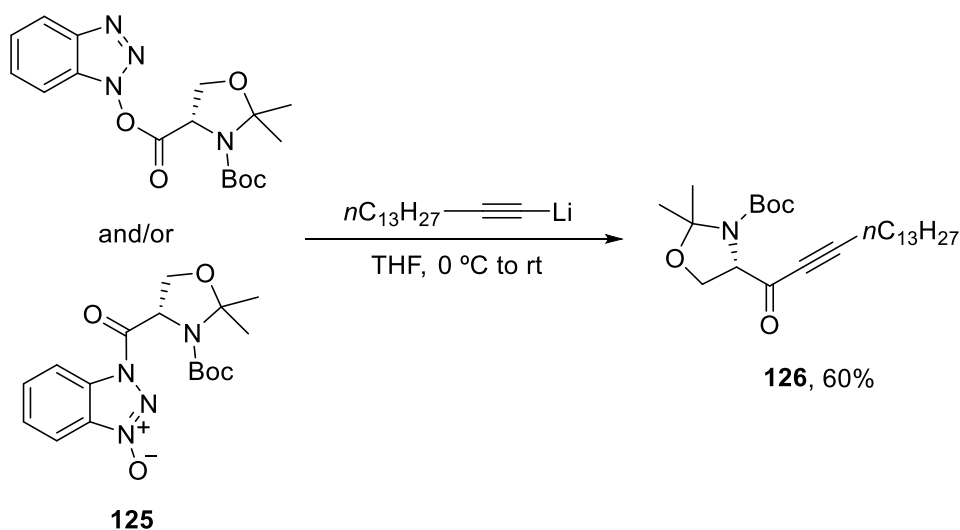

A one-pot synthesis of ynones from aliphatic and aromatic sodium carboxylates using 2,4,6-trichloro-1,3,5-triazine (cyanuric chloride) and terminal alkynes **127** in the presence of Et_3N as base and magnesium chloride as Lewis acid in acetonitrile at room temperature has been described.¹¹⁷ The corresponding ynones (**71**), obtained in very good yields, were formed via the corresponding cyanuric esters (Scheme 32).

Scheme 32. Reaction of Sodium Carboxylates with Cyanuric Acid Chloride and Terminal Alkynes **127**

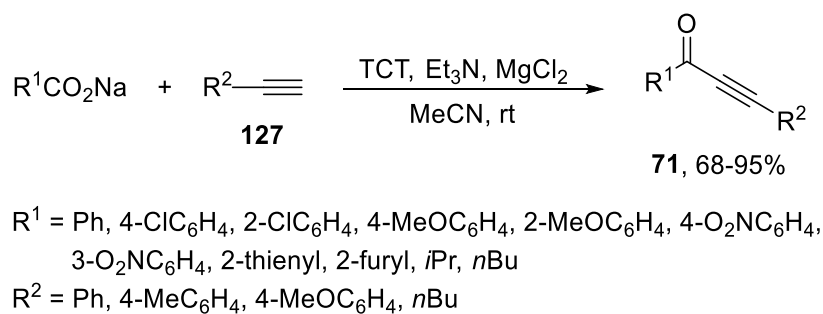

2.2.1.3. Acyl Chlorides and Anhydrides. Direct acylation of acetylides derived from alkali or alkaline-earth metals with acyl chlorides usually leads to complex reaction mixtures.¹¹⁸ However, the reaction of the alkynyllithium generated by deprotonation of **128** with LDA with different acyl chlorides at $-78\text{ }^\circ\text{C}$ gave the corresponding ynones **129** in moderate to good yields (Scheme 33).¹¹⁹ These ynones gave tetra-*ortho*-substituted biaryls by a Diels–Alder reaction with 1-methoxy-1,3-cyclohexadiene (Section 3.2.3).

Scheme 33. Reaction of the Acyl Chlorides with the Alkynyllithium Derived from 128

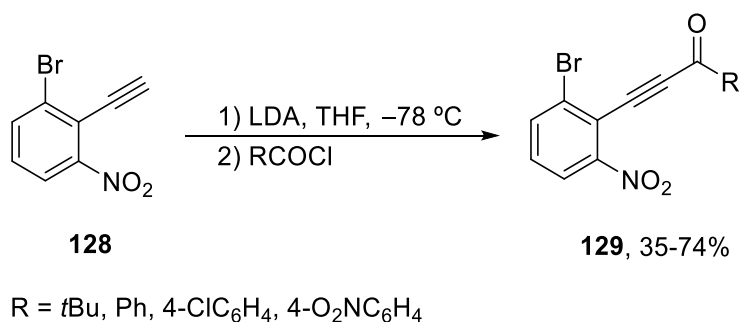

Recently, acetic anhydride has been also used for the acetylation of an alkynyllithium derived from the alkyne **130** affording ynone **131** in good yield (Scheme 34).¹²⁰ This method resulted a more direct and higher-yielding way to prepare this ynone than using a three-step procedure based on the reaction of the alkynyllithium with acetaldehyde followed by oxidation with MnO_2 .

Scheme 34. Reaction of Acetic Anhydride with the Alkynyllithium Derived from 130

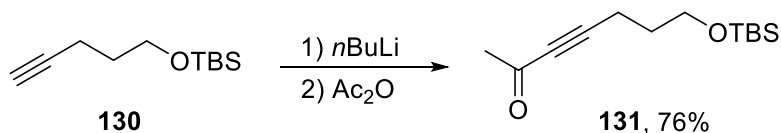

Baldwin and co-workers have used acetic and benzoic anhydrides for the acylation of the alkynyllithium derived from ethynylpyrazole **132**.¹²¹ The reaction afforded the corresponding ynones **133** in moderate yields (Scheme 35).

Scheme 35. Reaction of Acid Anhydrides with the Alkynyllithium Derived from Ethynylpyrazole 132

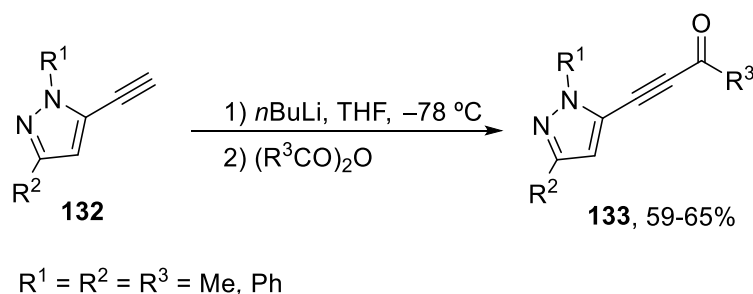

Micouin and co-workers described that dimethylalkynylaluminums are appropriate alkynylmetals for the general alkynylation of aliphatic and aromatic acyl chlorides providing the corresponding ynones **71** in moderate to excellent yields (Scheme 36).¹²² The reaction can be performed by treatment of terminal alkynes **127** with trimethylaluminum giving the acetylide **134** at $-60\text{ }^\circ\text{C}$ in the presence of a catalytic amount of Et_3N . The acylation must be carried out in 1,2-dichloroethane at $0\text{ }^\circ\text{C}$ with acyl chlorides **135**. Alternatively, dichloromethane and toluene also proved to be suitable solvents for the alkynylation of acyl chlorides.

Scheme 36. Reaction of Acyl Chlorides with Dimethylalkynylaluminum Reagents

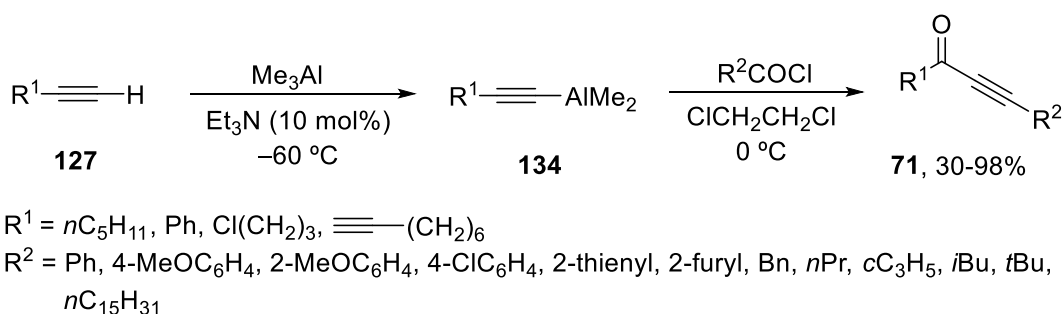

Potassium alkynyltrifluoroborates **135** reacted cleanly with aliphatic and aromatic acyl chlorides using BCl_3 as Lewis acid.¹²³⁻¹²⁵ The corresponding ynones **71** were obtained in moderate to high yields using dichloromethane as solvent at room temperature (Scheme 37). A possible mechanism has been proposed involving the formation of an alkynyldichloroborane species by reaction of potassium alkynyltrifluoroborate **135** with boron trichloride.¹²⁶ This methodology has been applied to prepare steric hindered alkynoylphenols using 2,6-disubstituted acyl chlorides, precursors of flavones and auronones.¹²⁵

Scheme 37. Reaction of Acyl Chlorides with Potassium Alkynyltrifluoroborates **135** in the Presence of BCl_3

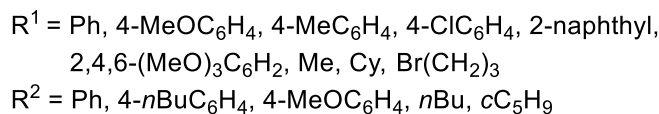
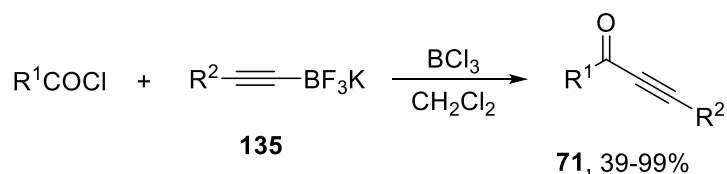

Alkynylsilanes can be acylated with cyclic anhydrides in the presence of AlCl_3 as Lewis acid.¹²⁷ This methodology has been used for the total synthesis of resolving E1, a metabolite of the omega-3 fatty acid eicosapentaenoic acid (EPA) with potent anti-inflammatory activity. Bis(trimethylsilyl)acetylene reacts with glutaric anhydride giving after esterification ester ynone **137** in good yield (Scheme 38).¹²⁸

Scheme 38. Reaction of Glutaric Anhydride with Bis(trimethylsilyl)acetylene (136) in the Presence of AlCl_3

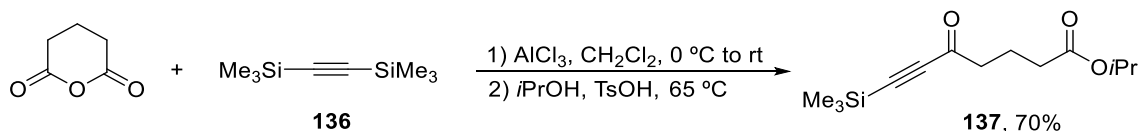

Zhu and Wu have performed the synthesis of an anti-melanogenic glycerol fatty acid ester isolated from the tuber-barks of *Colucasia antiquorum* var. *esculeta* using ynone **140** as intermediate. This ynone has been prepared in 30% yield by reaction of azelaic anhydride **138** with alkynylsilane **139** in the presence of aluminum trichloride in dichloromethane (Scheme 39).¹²⁹

Scheme 39. Reaction of Azelaic Anhydride 138 with Alkynylsilane 139 in the Presence of AlCl_3

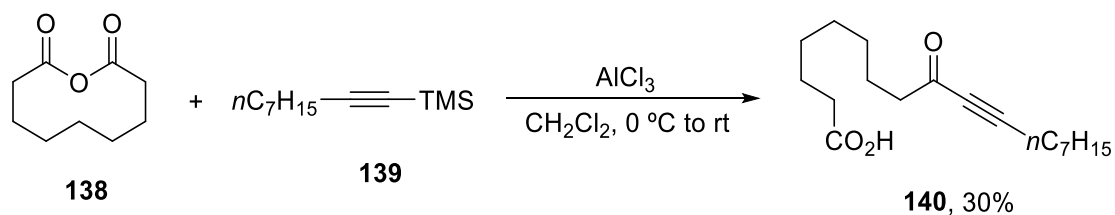

Baldwin and co-workers performed the acylation of bis(trimethylsilyl)buta-1,3-diyne with acetyl and benzoyl chloride at 0 °C in the presence of AlCl_3 .¹²¹ The corresponding diynones **141** were isolated in high yields (Scheme 40).

Scheme 40. Reaction of Acyl Chlorides with Bis(trimethylsilyl)buta-1,3-diyne in the Presence of AlCl_3

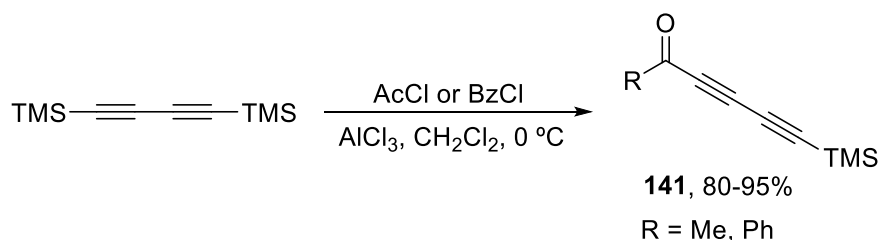

1-Ethoxyoxalyl-2-chloroacetylene **143**, used as dienophile in Diels-Alder reactions (Section 3.2.3), has been synthesized by acylation of bis(trimethylstannyl)acetylene.¹³⁰ In this case, the addition of lithium chloroacetylide to various oxalic acid derivatives as well as the acylation of bis(trimethylsilyl)acetylene (**136**) failed. However, ethoxyoxalyl chloride reacted with the distannylated acetylene at room temperature under solvent- and catalyst-free conditions to provide 1-ethoxyoxalyl-2-trimethylstannylacetylene (**142**) in 82% yield (Scheme 41). This compound was further treated with chlorine and gave dienophile **143** in 90% yield.

Scheme 41. Synthesis of 1-Ethoxyoxalyl-2-chloroacetylene (**143**)

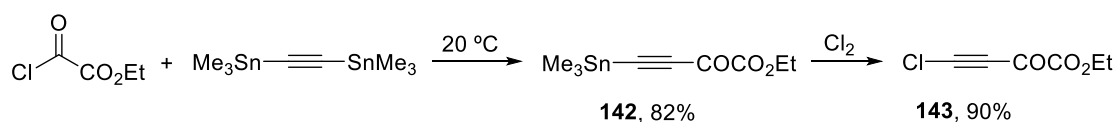

2.2.1.4. Nitriles. Nitriles can be also used as acylating reagents of organolithium and organomagnesium reagents. However, only two examples have been described by Deng and co-workers,¹³¹ the alkynylation of diethoxyacetonitrile (**144**) with phenylethynylmagnesium bromide and 1-hexynyllithium affording ynones **145a** and **145b**, respectively, in moderate yields (Scheme 42).

Scheme 42. Reaction of Diethoxyacetonitrile (**144**) with Magnesium and Lithium Acetylides

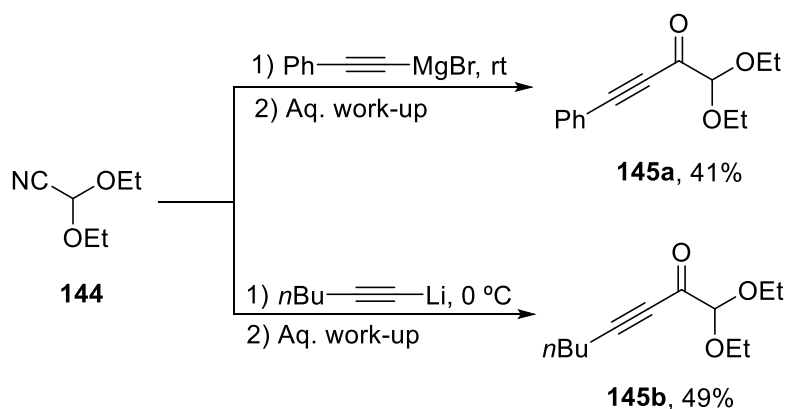

In conclusion, for the synthesis of ynones by acylation of organometallic reagents the most reliable and widely used methodology is the alkynylation of amides, especially Weinreb amides, employing alkynyllithium and alkynylmagnesium reagents.

2.2.2. Metal-Catalyzed Alkynylation of Acid Derivatives. Transition-metal-catalyzed Sonogashira acylation of alkynes is a traditional route for the synthesis of ynones.¹³²⁻¹³⁷ In this section, Pd-catalyzed acylation of alkynes with and without CuI will be considered. In addition, acylation of terminal alkynes catalyzed by CuI will be also considered for the synthesis of ynones as well as other alternative methods.

2.2.2.1. Palladium- and Copper-Catalyzed Acylation of Terminal Alkynes. The typical synthetic protocol to form ynones is the use of Pd(PPh₃)₂Cl₂ and CuI bimetallic system as catalyst, initially established by Sonogashira and Hagihara¹³⁸ for the reaction of acyl chlorides with terminal alkynes at room temperature in a big excess of Et₃N. Karpov and Müller performed the synthesis of (trimethylsilyl) ethynyl ketones by reaction of aryl and heteroaryl acyl chlorides with (trimethylsilyl)acetylene using 1 eq of Et₃N and THF as solvent with higher yields than the Stille coupling of acyl derivatives with (trimethylsilyl)ethynyltetra-*n*-butylstannane (Scheme 43).¹³⁹ Among the several catalysts assayed, Pd(PPh₃)₂Cl₂ with or without CuI and only CuI, the Pd/Cu bimetallic mixture was the most efficient. Subsequent transformations of the silylated ynones **16** into enaminones by reaction with amines, and in pyrimidines by *in situ* addition of amidines have been performed. Further studies from the same group with different aryl and alkyl acetylenes under the same reaction conditions gave the corresponding ynones, which were allowed to react *in situ* with amines and amidines.¹⁴⁰ The corresponding enaminones (74-99%) and pyrimidines (26-84%) were isolated in general with good yields. The same ynones have been allowed to react *in situ* with tryptamine derivatives and then with acryloyl chlorides affording tetrahydro- β -carbolines in 32-59% yields.¹⁴¹

Scheme 43. Coupling of Acyl Chlorides with (Trimethylsilyl)acetylene under Pd/Cu Catalysis

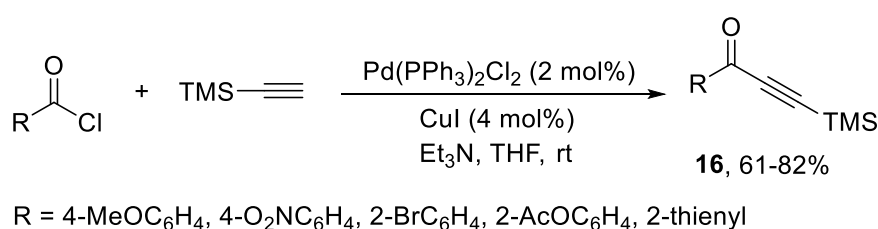

Ferrocenylnones **147** have been prepared in modest to good yields by coupling ferrocenylacetylene (**146**) with vinyl, aryl and heteroaryl acid chlorides and 10 mol% of Pd(PPh₃)₂Cl₂/CuI in anhydrous Et₃N at room temperature (Scheme 44).¹⁴² Potential applications of this type of ketones are as photoactive semiconductors and liquid crystals.

Scheme 44. Coupling of Acyl Chlorides with Ferrocenylacetylene (146) under Pd/Cu Catalysis

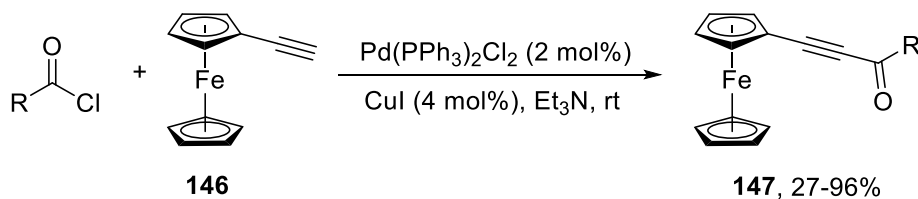

R = H₂C=C(Me), PhCH=CH, Ph, 4-BrC₆H₄, 2-ClC₆H₄, 4-O₂NC₆H₄, 3-MeC₆H₄, 4-MeC₆H₄, 4-NCC₆H₄, 3,5-(O₂N)₂C₆H₃, 3,4-(MeO)₂C₆H₃, 2-furyl, 1-naphthyl,

Chen and Li have performed the former coupling in water with sodium lauryl sulfate (7 mol%) as the surfactant and K₂CO₃ as the base using 2 mol% of Pd(PPh₃)₂Cl₂ and 5 mol% of CuI at 65 °C. Aromatic acyl chlorides and aliphatic and aromatic acetylenes gave the corresponding ynones in good yields (51-98%).¹⁴³ Cox and co-workers have employed the Müller reaction conditions to synthesize ynones using different functionalized alkynes and aliphatic or aromatic acyl chlorides.¹⁴⁴

Müller and co-workers have synthesized 3-halofurans **148** applying a one-pot Sonogashira procedure using acyl chlorides and tetrahydropyranyl (THP)-protected propargyl alcohols **114**, followed by addition of NaCl or NaI and *p*-toluenesulfonic acid (PTSA) to the *in-situ* generated ynone **I** (Scheme 45).^{145,146} Furans **148** can be further *in-situ* cross-coupled with arylboronic acids giving trisubstituted furans. The ynones resulting from the coupling of acyl chlorides and *N*-Boc protected propargylamines have been allowed to react *in situ* with NaI affording 4-iodopyrroles **149** in good yields.¹⁴⁷

Scheme 45. Coupling of Acyl Chlorides with THP-Protected Propargyl Alcohols **114** using Pd/Cu Catalysis

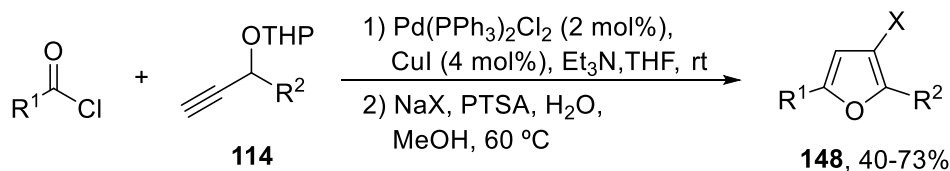

R¹ = Ph, 4-MeOC₆H₄, 4-O₂NC₆H₄, 2-FC₆H₄, 2-thienyl, PhCH=CH, 1-cyclohexenyl
 R² = H, Et
 X = Cl, I

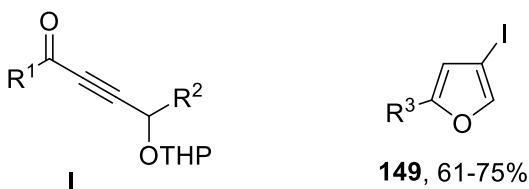

R³ = Ph, 4-MeC₆H₄, 3-MeC₆H₄, 2-MeC₆H₄, 4-MeOC₆H₄, 4-ClC₆H₄, 4-FC₆H₄, 2-thienyl, PhCH=CH, *c*-C₃H₅, 1-adamantyl

These types of one-pot alkyne-ylation under Sonogashira-Hahigara conditions followed by heterocyclization have been studied by several groups and applied to the synthesis of heterocyclic compounds (Section 3.2). For instance, Jiang and co-workers have used ynones **71** and hydrazines for the synthesis of pyrazoles and also amidines for the

preparation of pyrimidines (Figure 6).¹⁴⁸ (*Z*)-Enaminones have been prepared by Cacchi and co-workers by reaction of ynones **18** with primary amines and further transformed into 1,2-disubstituted 4-quinolones in 53-93% yields (Figure 6).¹⁴⁹ By using *ortho*-iodoanilines, ynones **71** gave enaminones which were transformed into 3-aryloindoles also by the same group.¹⁵⁰ Furthermore, Kitagawa and co-workers have prepared atropisomeric 2-aryl-4-quinolinone derivatives using ynones **18** (X = Br) derived from the coupling of *o*-bromo acyl chlorides with terminal alkynes.¹⁵¹ Langer, Forashenko and co-workers have prepared ynones **150**, derived from the Sonogashira–Hagihara coupling of 2-fluoro-5-nitrobenzoyl chloride with terminal alkynes, for the synthesis of 6-nitro- and 6-aminoquinolones (Figure 6).¹⁵² Müller and co-workers have prepared blue luminescent biaryls substituted pyrazoles using the sequential Sonogashira–Hagihara coupling followed by reaction with monosubstituted hydrazines.¹⁵³⁻¹⁵⁵ Liu and co-workers have trapped ynones **71** with hydroxylamine hydrochloride for the synthesis of 3,5-disubstituted isoxazoles (Figure 6) (see Scheme 170).¹⁵⁶

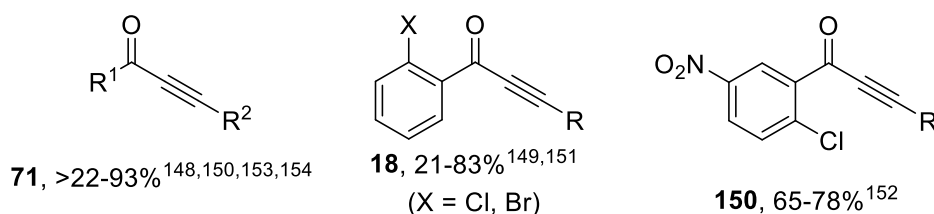
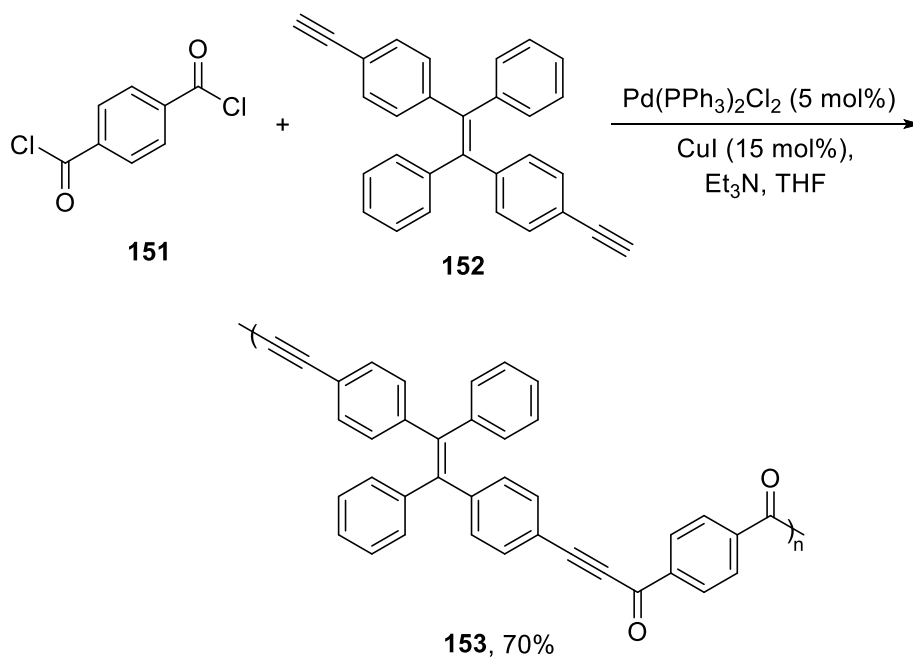

Figure 6. Selected ynones prepared for the synthesis of heterocycles.

A fluorescent sensor poly(arylene ynonylene) **153**, with high molecular weight, has been prepared by Tang and co-workers¹⁵⁷ by a new polymerization route. The Sonogashira–Hagihara reaction of the tetraphenylethylene (TPE) derivative **152** with terephthaloyl chloride **151** under Pd(PPh₃)₂Cl₂/CuI catalysis promoted a polymerization affording poly(arylene ynonylene) **153** (MW = 39100) in 70% yield (Scheme 46).

Scheme 46. Synthesis of Poly(arylene ynonylene) 153



Recently, a phosphinito Pd(II) complex (**154**) and CuI, both in 5 mol% loading, were used as catalysts for the preparation of ynones **71** ($\text{R}^1 = \text{aryl, heteroaryl}$; $\text{R}^2 = \text{aryl, alkyl}$) which were obtained in high yields (80-93%).¹⁵⁸ This methodology has been applied to the synthesis of the natural product anemarchalconyn (**156**, by reaction of acyl chloride **155** and acetylene **111**) which exhibits inhibitory effects at the adipogenic differentiation of preadipocyte 3T3-L1 cells (Scheme 47).

Scheme 47. Synthesis of Anemarchalconyn 156 from Compounds 155 and 111

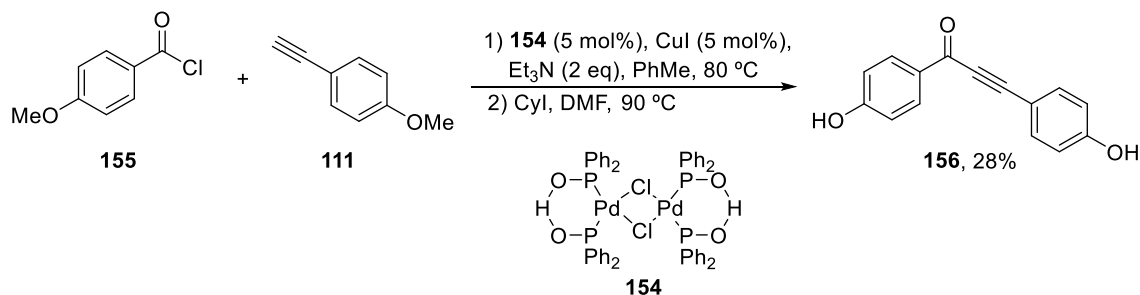

Heterogeneous Pd catalysts have been developed in order to recover and reuse them and for easier separation of catalysts and products than under homogeneous conditions. Tsai and co-workers reported a nanosized mesoporous silica material MCM-41 with anchored palladium bipyridyl complex, NS-MCM-41-Pd, for the general formation of ynones.¹⁵⁹ This catalyst worked with very low catalyst loading (0.002-0.1 mol%) in the presence of triphenylphosphine and CuI in Et_3N as solvent at 50 °C (Scheme 48). The reaction can be scaled up to 150 mmol and the catalyst was recycled over four runs with moderate drop in the yield (from 98 to 90%).

Scheme 48. Coupling of Acyl Chlorides and Terminal Alkynes 127 Catalyzed by NS-MCM-41-Pd/CuI/PPh₃

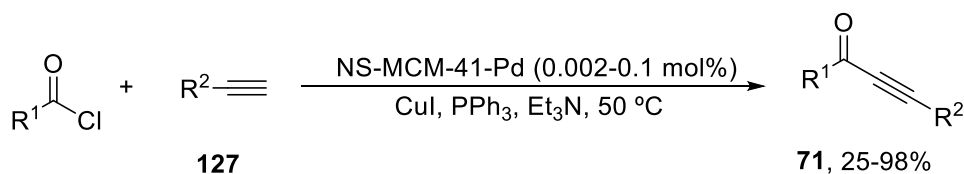

R¹ = Ph, 4-MeOC₆H₄, 4-MeC₆H₄, 2-MeC₆H₄, 4-ClC₆H₄, 2-furyl, 2-thienyl, Cy, *i*Pr, *t*Bu, *n*Bu

R² = Ph, 4-MeOC₆H₄, 2-MeOC₆H₄, 4-ClC₆H₄, 4-MeC₆H₄, 2-MeC₆H₄, 4-O₂NC₆H₄, 1-naphthyl, 9-anthracenyl

Cai and co-workers have developed a phosphine-free heterogeneous catalyst for the coupling of acyl chlorides with terminal alkynes based on a 3-(2-aminoethylamino)propyl functionalized MCM-41-immobilized palladium complex MCM-41-2N-Pd(OAc)₂ (0.2 mol%) and CuI (0.2 mol%) in Et₃N at 50 °C (Scheme 49).¹⁶⁰ The corresponding ynones (**71**) were obtained in high yields and recycling experiments showed a high recycling ability during at least 10 runs. Cai and his group also performed *in situ* coupling with this catalyst, and cyclocondensation with hydrazines allowed the synthesis of pyrazoles.¹⁶¹ Again excellent recycling and reuse performance was achieved during at least 10 consecutive trials.

Scheme 49. Coupling of Acyl Chlorides and Terminal Alkynes **127 Catalyzed by MCM-41-2N-Pd(OAc)₂/CuI**

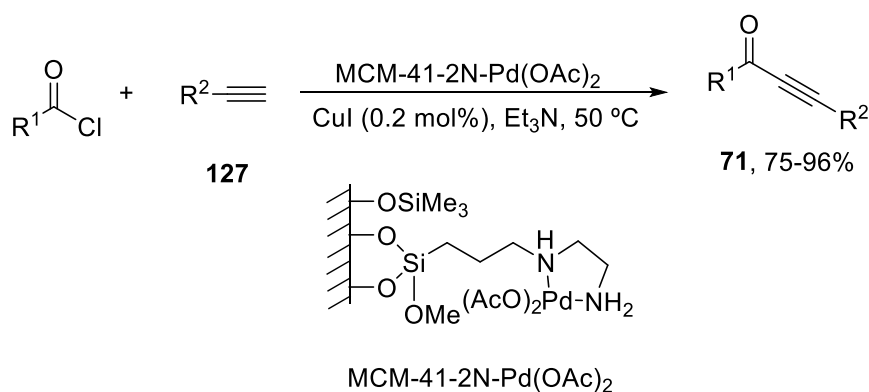

R¹ = Ph, 4-MeOC₆H₄, 4-MeC₆H₄, 4-ClC₆H₄, 4-O₂NC₆H₄, 2-furyl, 2-thienyl

R² = Ph, 4-MeC₆H₄, *n*Bu, *n*C₆H₁₃, MeOCH₂, TMS

Decarbonylative coupling has been reported as an alternative to the classical Sonogashira–Hagihara reaction for the synthesis of ynones. Friedel–Crafts glycosylation of indoles and pyrroles **157** with oxalyl chloride followed by decarbonylative alkylation allowed the synthesis of the corresponding ynones (**158**) in moderate to good yields (Scheme 50).¹⁶² This glycosylation-decarbonylative alkylation methodology set up by Müller and co-workers has been applied to prepare azulenyl and guaiazulenyl ynones **159**.¹⁶³ Ynones **158**¹⁶² have been further transformed into 2-aminopyrimidines by reaction with guanidinium hydrochloride and ynones **159**¹⁶³ into pyrimidines by treatment with amidines and into pyrazoles by reaction with *N*-methylhydrazine.

Scheme 50. Glyoxylation and Decarbonylative Sonogashira-Hagihara Coupling of Indoles and Pyrroles

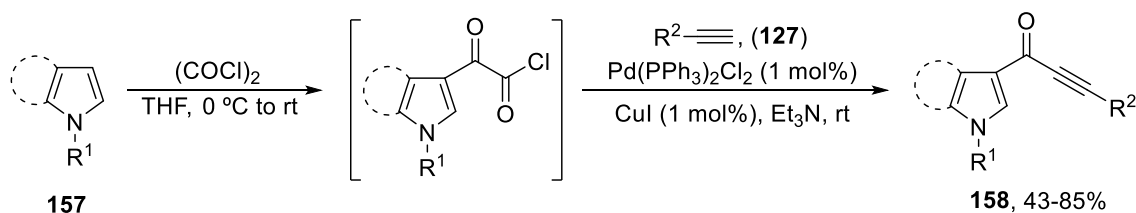

$R^1 = \text{H, Me, } n\text{Bu, TIPS}$

$R^2 = n\text{Bu, MeOCH}_2, \text{TMS, Ph}$

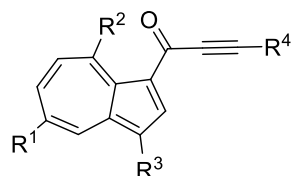

$R^1 = \text{H, } i\text{Pr}$

$R^2 = \text{H, Me}$

$R^3 = \text{H, Me}$

$R^4 = \text{Ph, 4-MeC}_6\text{H}_4, \text{4-NCC}_6\text{H}_4, \text{4-O}_2\text{NC}_6\text{H}_4, \text{4-FC}_6\text{H}_4, \text{3,5-(MeO)}_2\text{C}_6\text{H}_3, \text{2-thienyl, 2-Py, cC}_3\text{H}_5, n\text{Bu}$

Thiol esters **160** were used as acylating reagents for the Pd-catalyzed synthesis of ynones by Fukuyama and coworkers.¹⁶⁴ The reaction took place using $\text{PdCl}_2(\text{dppf})$ (5 mol%)/ $\text{P}(2\text{-furyl})_3$ (12.5 mol%) as catalysts and an excess of CuI (1.7 eq) in a 5:1 mixture of $\text{DMF}:\text{Et}_3\text{N}$ at 50 °C and the yields were good (Scheme 51). In order to avoid the unpleasant odor of ethanethiol, thiol esters derived from odorless dodecanethiol were further used.¹⁶⁵

Scheme 51. Coupling of Thiol Esters 160 with Terminal Acetylenes 127 Catalyzed by $\text{PdCl}_2(\text{dppf})$ in the Presence of CuI

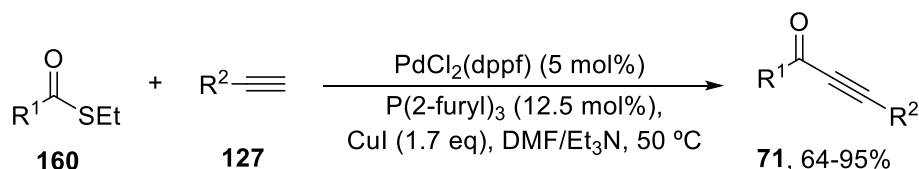

$R^1 = \text{4-MeOC}_6\text{H}_4(\text{CH}_2)_2, \text{PhCO}(\text{CH}_2)_2, \text{4-BrC}_6\text{H}_4(\text{CH}_2)_2, \text{PhCH}=\text{CH}, \text{3-ClC}_6\text{H}_4, \text{4-}i\text{PrOC}_6\text{H}_4, n\text{Bu}$

$R^2 = n\text{Bu, TIPSCH}_2, \text{Me}_2\text{COH, Ph, TBS, TIPS,}$

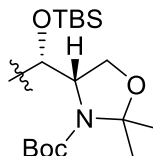

The main advantage of thiol esters compared to acyl chlorides is the compatibility with other functional groups in the skeleton of the acid derivative. Consequently, thiol ester coupling with alkynes has been applied to the synthesis of natural products. Kuwahara and co-workers have carried out the total synthesis of pteridic acids A and B using thiol

esters.¹⁶⁶ Thiol ester **161** was coupled with alkyne **162** under Fukuyama's conditions providing ynone **163** in good yield (Scheme 52).

Scheme 52. Coupling of Thiol Ester 161 with Alkyne 162 Catalyzed by PdCl₂(dppf) in the presence of CuI

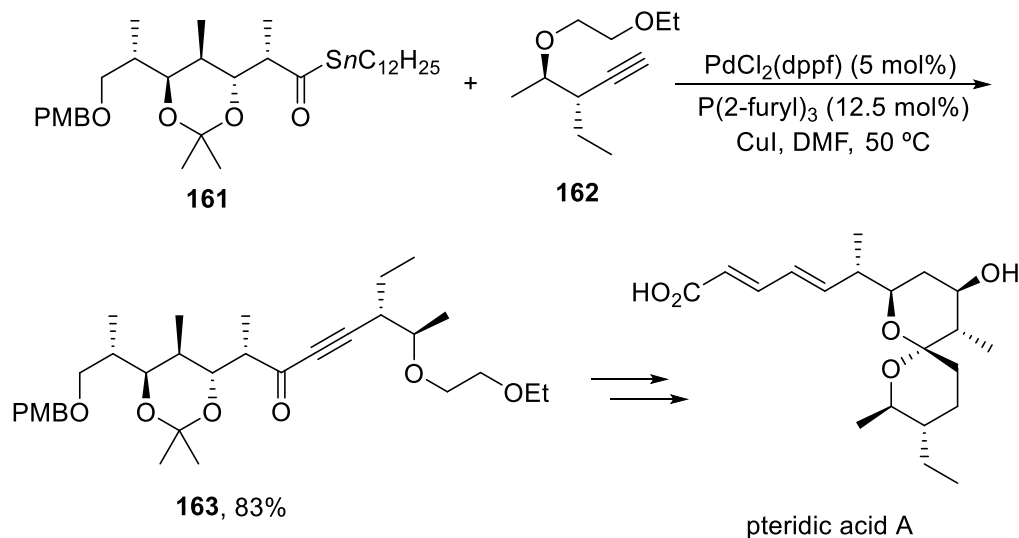

The cross-coupling of thiol ester **164** with the terminal acetylene **165** under Fukuyama's conditions took place in a moderate 55% yield due to a competitive Glaser type diyne formation (Scheme 53).¹⁶⁷ When treated with *p*-TsOH, the resulting ynone (**166**) gave a spiroketal, which is the C15-C25 fragment of the marine sponge natural product calyculin C. Koskinen and co-workers further reported the preparation the C9-C25 spiroketal dipropionate unit for the synthesis of the intermediate ynone **168** by coupling of thiol ester **164** with alkyne **167** in only 50% yield, due to dimerization of **167**.¹⁶⁸

Scheme 53. Coupling of Thiol Ester 164 with Alkynes 165 or 167 under Fukuyama's Conditions

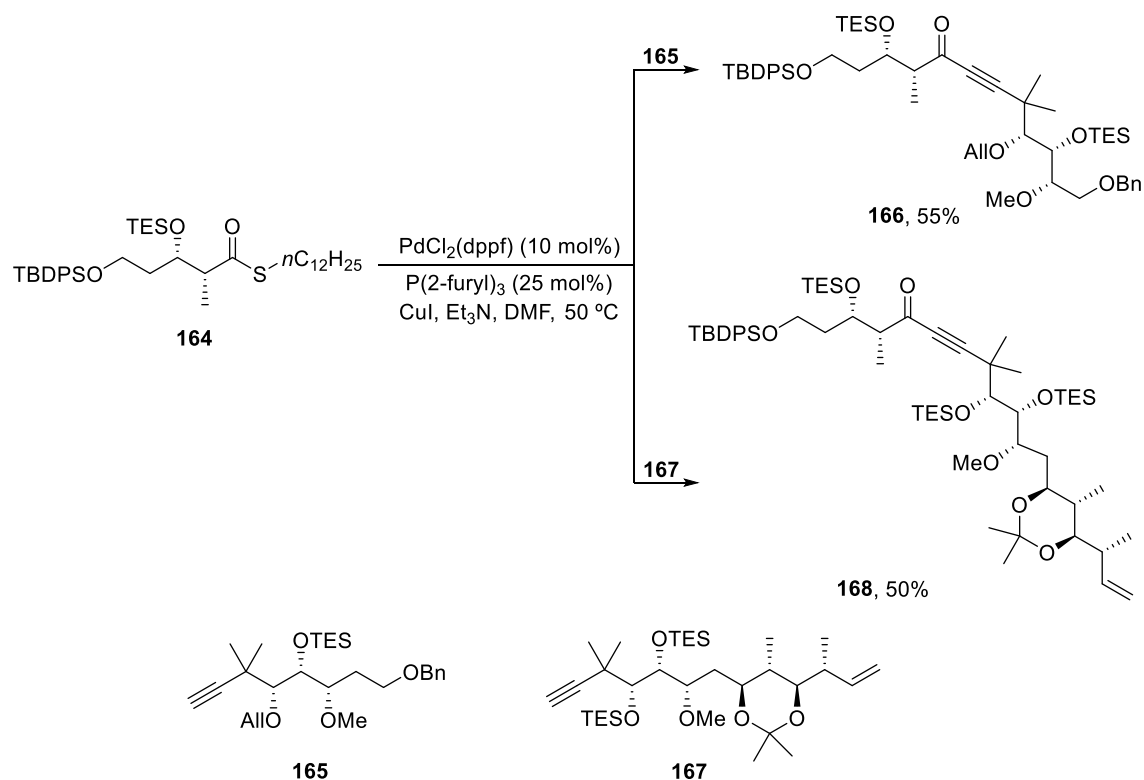

Fuwa and co-workers found out that *p*-toluenethiol esters **169** gave better results than the ethanethiol esters using $\text{Pd}_2(\text{dba})_3 \cdot \text{CHCl}_3$ in the coupling to terminal alkynes to provide ynones **170** (Scheme 54).^{169,170} These ynones were further transformed into 2,6-disubstituted-4*H*-pyran-4-ones by AgOTf -promoted intramolecular conjugate addition.

Scheme 54. Coupling of Thiol Esters **169** with Terminal Alkynes **127** under Modified Fukuyama's Conditions

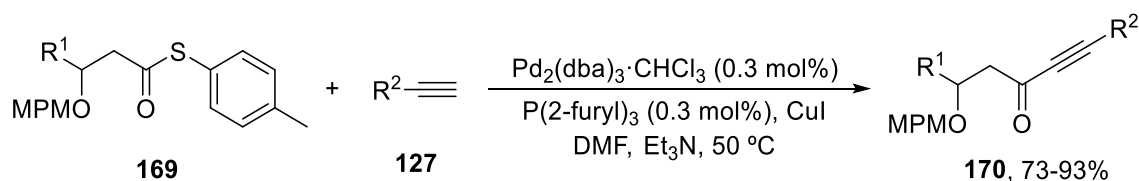

$\text{R}^1 = \text{BnO}(\text{CH}_2)_3, \text{Cy}$

$\text{R}^2 = n\text{Bu}, \text{Cy}, \text{TBDPSO}(\text{CH}_2)_3, \text{BnO}(\text{CH}_2)_3, \text{Ph}$

Telluro ester **171** has been used as acylating coupling partner in the Pd/Cu -catalyzed Sonogashira–Hagihara reaction for the synthesis of ynones, but the yields were only moderate (Scheme 55).¹⁷¹ The reaction took place with 2 eq of CuI and 10 mol% of $\text{Pd}(\text{PPh}_3)_4$ in Et_3N as solvent at room temperature.

Scheme 55. Coupling of Telluro Ester **171** with Terminal Alkynes **127** Catalyzed by $\text{Pd}(\text{PPh}_3)_4$ and CuI

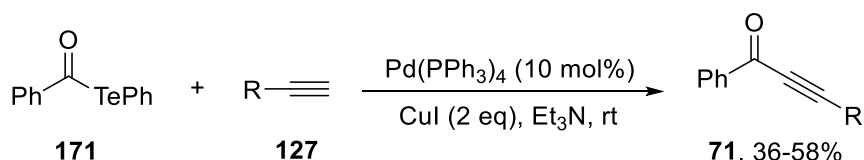

R = $n\text{C}_5\text{H}_{11}$, Ph, 4-*t*Bu C_6H_4 , 1-cyclohexenyl

In conclusion, for the synthesis of ynones under Pd/Cu catalyzed conditions only acyl chlorides can be used as acylating agents in the presence of substoichiometric amounts of CuI. For thiol esters *ca.* 2 eq of CuI are needed, but these acylating agents are more compatible with other functional groups than acyl chlorides.

2.2.2.2. Palladium-Catalyzed Copper-Free Acylation of Terminal Alkynes. Copper-free Sonogashira–Hagihara reaction was carried out with oxime-derived palladacycle **172** or Pd(OAc)₂ using 1.5 eq of Et₃N in toluene.¹⁷² The palladium loading can be maintained between 0.5 and 0.2 mol% working at room temperature and under reflux, respectively. In general, the palladacycle **172** was slightly more efficient than Pd(OAc)₂ affording the corresponding ynones in good yields (Scheme 56).

Scheme 56. Coupling of Acyl Chlorides with Terminal Alkynes **125 Catalyzed by Palladacycle **172** or Pd(OAc)₂**

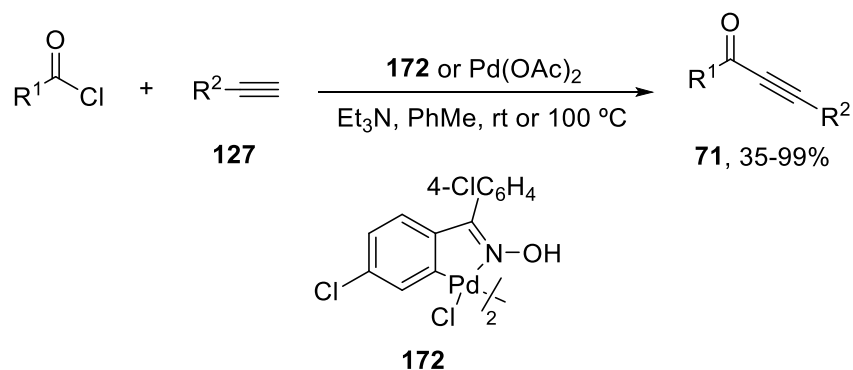

R¹ = Ph, 4-ClC₆H₄, 4-MeOC₆H₄, 3-MeOC₆H₄, 2-MeOC₆H₄, 4-*t*BuC₆H₄,
4-O₂NC₆H₄, 4-ClCOC₆H₄, 2-furyl, PhCH=CH, Cy, *t*Bu
R² = Ph, $n\text{C}_6\text{H}_{13}$, TIPS

Srinivasan and co-workers have used Pd(OAc)₂ (0.2 mol%) and 1 eq of Et₃N under solvent-free conditions at room temperature under argon affording the corresponding ynones **71** in good yields (40-95%).¹⁷³ The same group has performed the one-pot synthesis of 2,4-disubstituted benzodiazepines by adding the diamine in water to the reaction flask once the ynone was formed.¹⁷⁴ The one-pot synthesis of enaminones was performed under solvent-free conditions.¹⁷⁵

In the presence of ligands **173** (2 mol%) (Figure 7) and Pd(PPh₃)₂Cl₂ (2 mol%), Et₃N (3 eq) in toluene at 40 °C, acyl chloride and terminal alkynes afforded ynones **71** in 15-99%.¹⁷⁶ The Pd complex formed by ligand **174** and K₂PdCl₄ (2 mol%) under copper and

solvent free conditions catalyzed the coupling of acyl chlorides and terminal alkynes using only 1 equivalent of Et_3N providing ynones **71** in 65-90% yield.¹⁷⁷ The Pd complex derived from the salen ligand **175** (Figure 7) has been proved to be an efficient catalyst for the copper and solvent free alkynylation of aliphatic and aromatic acyl chlorides with terminal alkynes in the presence of 1 eq of Et_3N at room temperature.¹⁷⁸ The corresponding ynones were obtained in good yields (69-98%).

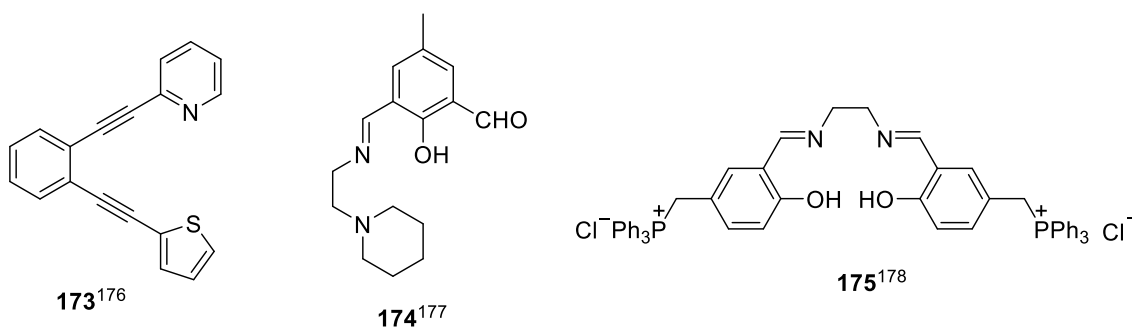

Figure 7. Ligands for the Pd-catalyzed coupling of acyl chlorides and terminal alkynes.

Pd/C was used as reusable palladium heterogeneous catalyst for the reaction of acyl chlorides with terminal alkynes. The acylation took place with 1 mol% of Pd/C, 0.2 eq of Et_3N under dry toluene reflux giving the corresponding ynones in 60-95% yield.¹⁷⁹ A moderate reusability was observed for the reaction of benzoyl chloride with phenylacetylene decreasing the yield from 96 to 57% after six cycles. Polystyrene-supported palladium(0) complex **176** (Figure 8) has been used as an efficient catalyst for the copper-free alkynylation of aromatic acid chlorides using 0.5 mol% of Pd and Et_3N (1 eq) as base at room temperature.¹⁸⁰ The corresponding ynones were obtained in good yields (74-97%) and good recyclability for the reaction of phenylacetylene with 4-chlorobenzaldehyde, affording the ynone in decreasing yield from 98 to 92% after 10 cycles. Bakherad and co-workers also studied another polymer-supported Pd(0) complex **177** (Figure 8) with an oxime thiosemicarbazone unit covalently bonded.¹⁸¹ Aromatic and heteroaromatic acyl chlorides reacted with aliphatic and aromatic acetylenes under reaction conditions similar to those applied with **176**. These copper and solvent-free couplings were carried out with 1 mol% of (Pd loading) **177** and 1 eq of Et_3N and the corresponding ynones were obtained in excellent isolated yields (93-95%). Moderate recyclability was found for the reaction of benzoyl chloride with phenylacetylene providing the resulting ynone in the range of 99 to 90% yields after 4 runs. Pd nanoparticles generated by thermolysis of $\text{Pd}(\text{OAc})_2$ embedded in a poly-1,4-phenylene sulfide (PPS) polymer matrix (PdNPs-PPS, **178**) have been used as efficient heterogeneous nanocatalyst system for the copper-free acyl Sonogashira–Hagihara coupling.¹⁸² This reaction took place in toluene at 50 °C in the presence of 1 eq of Et_3N providing ynones derived from aromatic and acyl chlorides in 15-98% yield. Moderate recyclability was observed up to the fourth cycle. Anchored PdNPs into single-walled carbon nanotubes SWNT-PdNPs (**179**), formed by thermolysis of $\text{Pd}(\text{OAc})_2$, was prepared by the same group.¹⁸³ The acylation takes place in moderate to good yields (43-98%) under mild reaction conditions using 1 eq of Et_3N in acetonitrile at room

temperature for aliphatic and aromatic acyl chlorides. The catalyst was recycled and reused up to seven cycles. Multiwalled carbon nanotubes (MWCNTs) functionalized with a palladium(II)-Schiff base complex **180** has been used as heterogeneous catalyst for the copper-, phosphorous- and solvent-free alkynylation of acyl chlorides.¹⁸⁴ When 0.6 mol% of Pd and 1.2 eq of Et₃N were applied at room temperature, the corresponding ynones were obtained in 53-94% yield and the catalyst could be recycled and reused only four times (yield decreased from 92 to 71%). Silica gel supported palladium catalyst **181**¹⁸⁵ (Figure 8) has been used in the coupling of aromatic acyl chlorides with phenylacetylene and 1.2 eq of Et₃N in toluene at room temperature, giving the corresponding ynones in 86-97% yield. The catalyst was recovered and reused in four cycles and the yield dropped from 87 to 68%. A nanocomposite, formed by magnetic nanoparticles coated by silica and covalently coupled to (3-aminopropyl)-trimethoxysilane (ASMNPs), was reacted with salicylaldehyde (Sc) and finally metalated with PdCl₂ and afforded Pd-Sc@ASMNPs **182** (Figure 8).¹⁸⁶ This catalyst was then used to alkynylate aromatic acyl chlorides with arylacetylenes using 1.5 eq of Et₃N in aqueous acetonitrile at room temperature and afforded ynones in 83-97% yields; **182** was recycled at least six times.

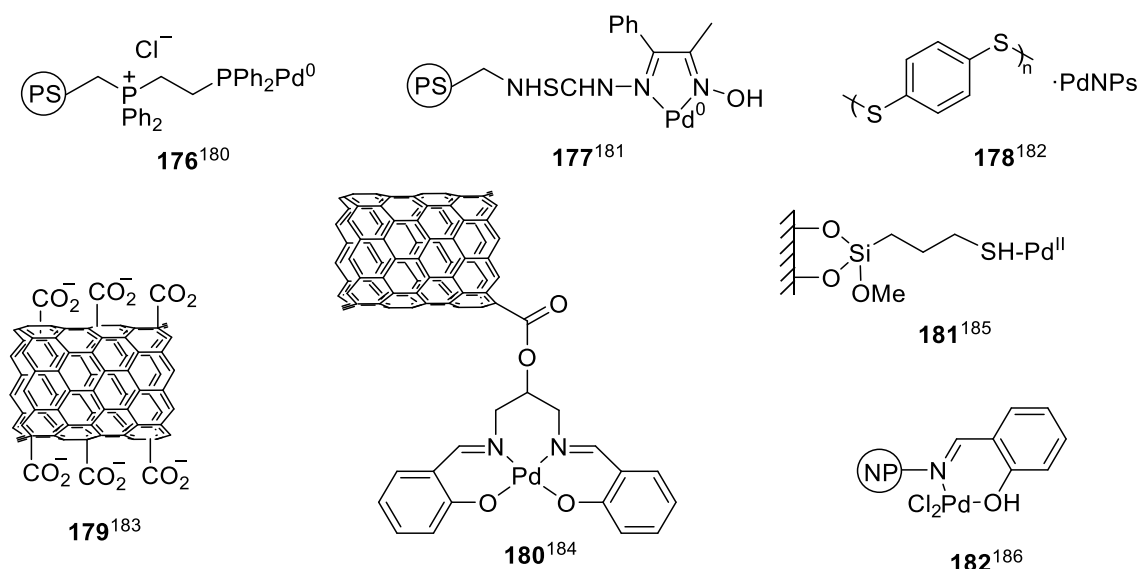
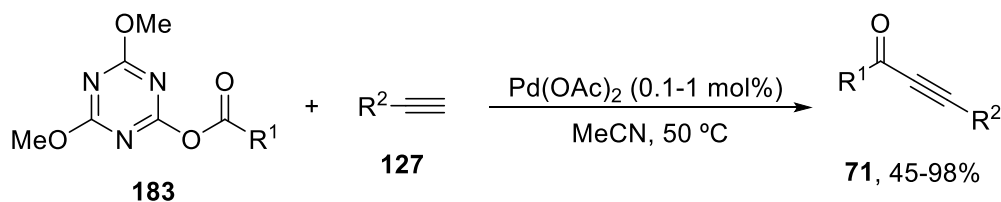

Figure 8. Selected supported Pd-catalysts for the alkynylation of acyl chlorides.

When triazine esters **183** were used as acylating reagents of terminal alkynes the corresponding ynones were obtained in good yields.¹⁸⁷ The coupling was performed with 0.1-1 mol% of Pd(OAc)₂ in acetonitrile at 50 °C in the absence of Et₃N (Scheme 57). This process has a wide range of functional tolerance and the N-Pd coordination with triazine plays a crucial role for the efficient C-O activation.

Scheme 57. Coupling of Triazine Esters 183 with Terminal Alkynes 127 Catalyzed by Pd(OAc)₂



$\text{R}^1 = \text{Ph, 4-MeOC}_6\text{H}_4, 4\text{-MeC}_6\text{H}_4, 3\text{-MeC}_6\text{H}_4, 2\text{-MeC}_6\text{H}_4, 4\text{-ClC}_6\text{H}_4, 4\text{-BrC}_6\text{H}_4, 4\text{-NCC}_6\text{H}_4, \text{ferrocenyl, 1-naphthyl, 2-thienyl, 1-adamantyl, } c\text{C}_4\text{H}_7, c\text{C}_5\text{H}_9$
 $\text{R}^2 = \text{Ph, 4-MeOC}_6\text{H}_4, 4\text{-MeC}_6\text{H}_4, 4\text{-EtC}_6\text{H}_4, 4\text{-BrC}_6\text{H}_4, 3\text{-ClC}_6\text{H}_4, n\text{Bu, } n\text{C}_5\text{H}_{11}, n\text{C}_6\text{H}_{13}, 2\text{-thienyl}$

Recently, amides **184** derived from saccharine have given access to ynones via C-N bond cleavage.¹⁸⁸ The reaction took place using 1 mol% of $\text{Pd(PPh}_3)_2\text{Cl}_2$ and 4 eq of Et_3N under THF reflux providing ynones in variable yield (Scheme 58). Other amides such as Weinreb amide, *N*-methyl-*N*-phenylamide, *N*-phenyl-*N*-tosylamide, *N*-benzoylsuccinimide, *N*-benzoylphthalimide and *N*-benzoylglutaramide failed to react.

Scheme 58. Coupling of *N*-Acylsaccharins **184 with Terminal Alkynes **127** Catalyzed by $\text{Pd(PPh}_3)_2\text{Cl}_2$**

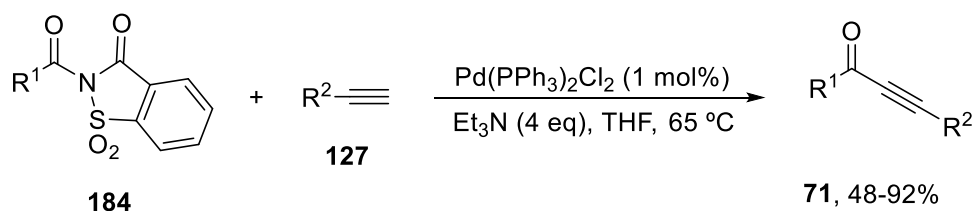

$\text{R}^1 = \text{Ph, 4-MeC}_6\text{H}_4, 4\text{-MeOC}_6\text{H}_4, 3\text{-MeOC}_6\text{H}_4, 2\text{-MeOC}_6\text{H}_4, 4\text{-FC}_6\text{H}_4, 4\text{-ClC}_6\text{H}_4, 4\text{-BrC}_6\text{H}_4, 4\text{-F}_3\text{CC}_6\text{H}_4, 4\text{-NCC}_6\text{H}_4, 4\text{-OHCC}_6\text{H}_4, 2\text{-naphthyl, 2-thienyl, PhCH=CH, Me, } n\text{C}_{11}\text{H}_{23}$
 $\text{R}^2 = \text{Ph, 4-MeC}_6\text{H}_4, 3\text{-MeC}_6\text{H}_4, 4\text{-}n\text{PrC}_6\text{H}_4, 4\text{-ClC}_6\text{H}_4, 4\text{-BrC}_6\text{H}_4, 4\text{-F}_3\text{CC}_6\text{H}_4, 4\text{-MeOC}_6\text{H}_4, 4\text{-PhC}_6\text{H}_4, 2\text{-thienyl, 3-thienyl, Ph(CH}_2)_2, n\text{Bu, } c\text{C}_3\text{H}_5$

In conclusion, the Sonogashira–Hagihara reaction of acyl chlorides with terminal alkynes can be efficiently performed under copper-free conditions, especially with heterogeneous catalysts under solvent-free conditions. New acylating reagents such as triazine esters and *N*-acylsaccharines have been recently used for the synthesis of a broad array of ynones under low Pd loading.

2.2.2.3. Copper-Catalyzed Acylation of Terminal Alkynes. The copper-promoted Stephen–Castro reaction for the cross-coupling of acyl iodides with terminal alkynes was reported in 1963.¹⁸⁹ However, the acylation of alkynes with acyl chlorides catalyzed by CuI (5 mol%) was described 33 years later by Chowdhury and Kundu in Et_3N at room temperature.^{190,191} And again, this Cu(I) -catalyzed reaction was not used until recently for the synthesis of ynones. Movassagh and co-workers have described the catalytic Stephen–Castro reaction using CuI/cryptand 22 complex **185** as a highly active catalyst

for the solvent-free cross-coupling acylation reaction using 1.2 eq of Et₃N under air at 60 °C giving the corresponding ynones **71** (Scheme 59).¹⁹²

Scheme 59. Coupling of Acyl Chlorides with Terminal Alkynes **127 Catalyzed by CuI/Complex **185****

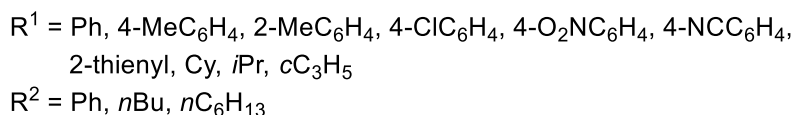
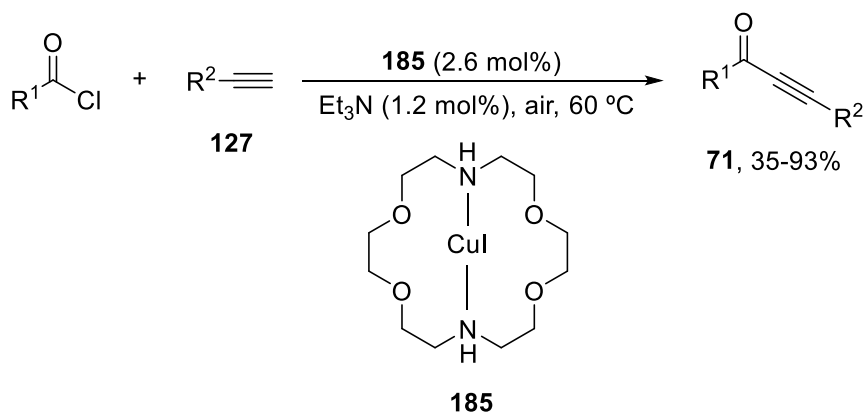

Yin and co-workers¹⁹³ have also used the CuI (2 mol%) and tetramethylethylenediamine (TMEDA, 5 mol%) catalytic system under solvent-free conditions as in the previous method. In this case, 3 eq of Et₃N were used under nitrogen at room temperature providing ynones in 84-95% yield. Aliphatic and aromatic acyl chlorides and terminal alkynes were successfully used.

Different copper NPs have been used as heterogeneous catalyst for the alkylation of acyl chlorides. Thus, Gao and co-workers prepared silica gel supported Cu-NPs (1 mol%) as catalyst and Et₃N (3 eq) as base under solvent-free conditions at 40 °C for the coupling of aliphatic and aromatic acyl chlorides and terminal alkynes.¹⁹⁴ The resulting ynones were obtained in general in good yields (35-98%). Recycling experiments for the reaction of benzoyl chloride with phenylacetylene during three cycles gave 92 to 85% yields. Bhanage and co-workers¹⁹⁵ have described a rapid route for the synthesis of Cu/CuO NPs from Cu(OAc)₂ in 1,3-propanediol by microwave heating (600 W) for three minutes. This nanocrystalline catalyst (10 mol%) showed good catalytic activity in the presence of Et₃N and toluene as solvent under nitrogen atmosphere at 90 °C for the synthesis of ynones from aromatic and aliphatic acyl chlorides and terminal alkynes in 63-99% yield (recycling experiments have not been reported). The mesoporous (MP) phenol-formaldehyde resin-supported copper NPs with high surface area and uniform narrow pore-size distribution have been used by Zhang and co-workers.¹⁹⁶ This heterogeneous Cu catalyst showed good catalytic activity (1 mol%) in the solvent-free synthesis of ynones in the presence of 1.5 eq of Et₃N at 40 °C: Aromatic and aliphatic acyl chlorides and terminal acetylenes afforded the corresponding ynones in 71-99% yield. In addition, these Cu NPs@MP could be reused and recycled at least 10 times with only 0.17% of the

Cu species leaching after 10 cycles. High ordered mesoporous tin silicates (PS-2) and CuI catalyzed the acylation of aliphatic and aromatic terminal alkynes with acyl chlorides in Et₃N as solvent at room temperature giving the corresponding ynones in 76-97% yield.¹⁹⁷ The catalyst has been recovered and reused for four cycles. A plausible mechanism has been proposed attributing to the PS-2 catalyst the coordination to the carbonyl group (**I**) which facilitates the cleavage of the C-Cl bond and the reaction with the copper acetylide (**II**) (Scheme 60).

Scheme 60. Mechanism Involved in the Coupling of Acyl Chlorides with Terminal Alkynes 127 Catalyzed by CuI and PS-2

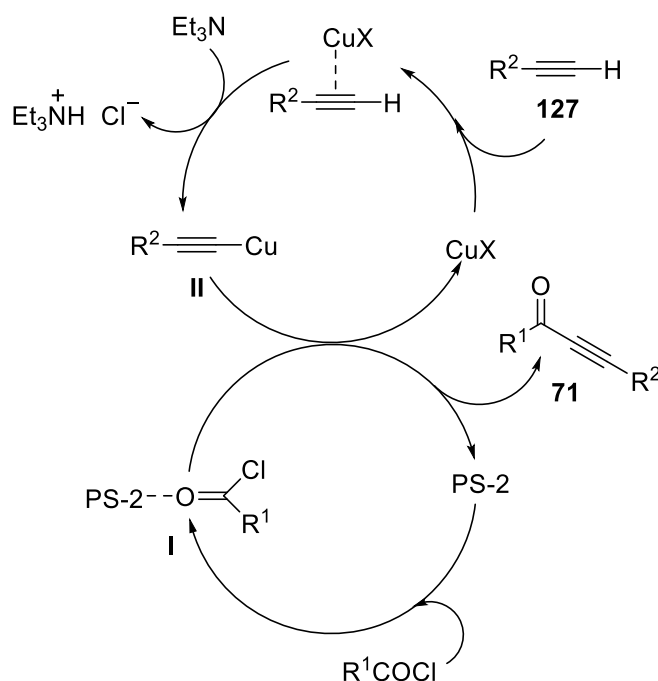

2-Oxo-3-butynoates and 2-oxo-3-butyenamides **187** have been prepared by CuI-catalyzed coupling of terminal alkynes with monoxyalyl chlorides **186** by Zhang and co-workers.¹⁹⁸ The reaction took place using 5 mol% of CuI and 2 eq of Et₃N in THF at room temperature giving the corresponding acetylenic α -keto esters **187** in good yields (Scheme 61).

Scheme 61. Coupling of Monoxyalyl Chlorides 186 with Terminal Alkynes 127 Catalyzed by CuI

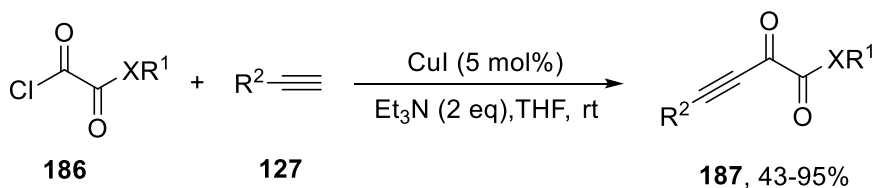

XR¹ = O*i*Pr, OEt, NEt₂

R² = Ph, 4-O₂NC₆H₄, 4-F₃CC₆H₄, 4-MeOC₆H₄, 1-naphthyl, *t*Bu, BnOCMe₂, TMS, TBS

Müller and co-workers have described the *in situ* glyoxylation-Stephen-Castro coupling sequence for the synthesis of ynediones.¹⁹⁹ Indoles, pyrroles, pyrazoles, thiophenes, furans and azulene were allowed to react with oxalyl chloride and then with terminal acetylenes in the presence of CuI (5 mol%) in Et₃N at room temperature providing ynediones **188** in modest to good yields (Scheme 62).

Scheme 62. Glyoxylation-Stephen-Castro Sequence to Give α -Keto Ynones **188**

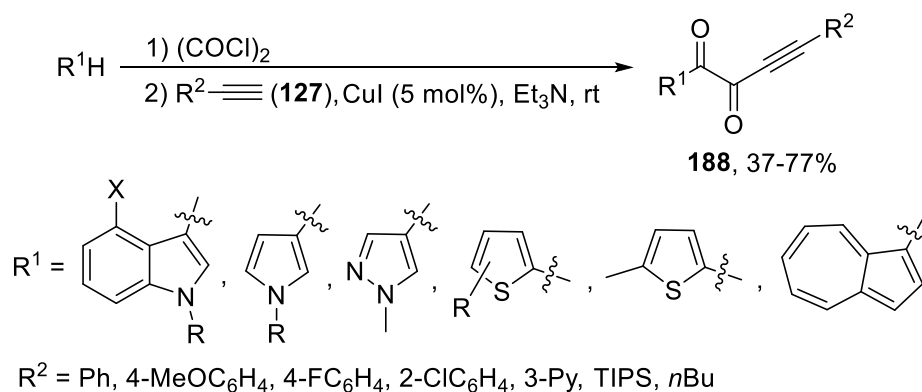

The former process maintains both carbonyl groups whereas the Pd/Cu decarbonylative Sonogashira coupling gives rise to the synthesis of ynones (Section 2.2.2.1). Ynediones **188** can be also prepared starting from aryl or heteroaryl glyoxylic acids **189** by *in situ* activation with oxalyl chloride in 1,4-dioxane followed by Stephen-Castro alkylation catalyzed by CuI (5 mol%) in the presence of 3 eq of Et₃N (Scheme 63).²⁰⁰ The corresponding ynediones derived from aryl, cinnamyl, furyl and thienyl α -keto carboxylic acids were obtained in modest yields.

Scheme 63. Reaction of α -Keto Acids **189 with Oxalyl Chloride Followed by Stephen-Castro Alkylation**

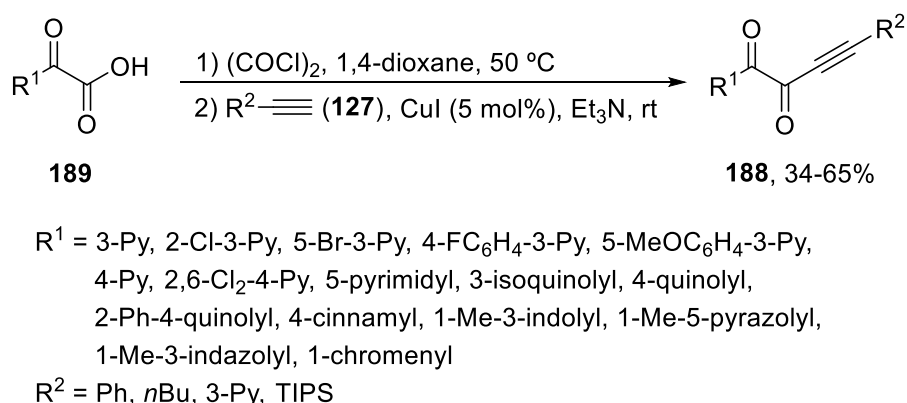

In conclusion, CuI is a general catalyst for the coupling of acyl chlorides in the synthesis of ynones and α -keto ynones under mild reaction conditions, the presence of Et₃N being necessary to accomplish these couplings.

2.2.2.4. Copper-Catalyzed Acylation of Alkynylmetals. Hosomi and co-workers²⁰¹ described the CuCl-catalyzed cross-coupling of alkynylsilanes with aliphatic and aromatic acyl chlorides in 1,3-dimethyl-2-imidazolidione (DMI) at 80 °C. In this process the silicon is transfer to copper giving the intermediate copper(I) acetylides which after acylation provided ynones in 73-98% yield. Gallagher and Maleczka²⁰² performed the *in situ* silylation of terminal alkynes with polymethylhydrosilane (PMHS) in combination with CsF, which in the presence of acyl chlorides afforded ynones **71** under CuCl-catalysis in NMP at 80 °C (Scheme 64).

Scheme 64. Coupling of Acyl Chlorides with Alkynylsilanes Generated *in situ* under CuCl Catalysis

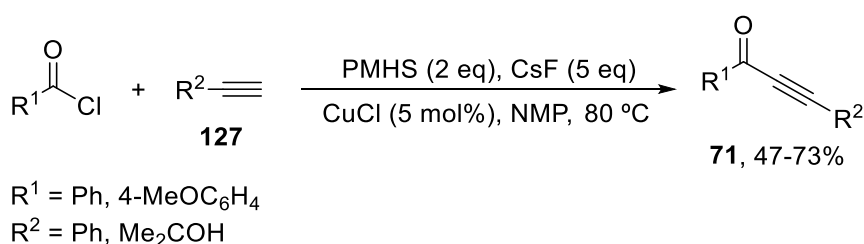

Nishihara and co-workers²⁰³ have described the cross-coupling of alkynylboronates **190** with acyl chlorides mediated by CuCl (2 eq) under harsh reaction conditions in DMI as solvent at 120 °C. The corresponding ynones **71** were obtained in moderate to good yields (Scheme 65).

Scheme 65. Coupling of Acyl Chlorides with Alkynylboronates **190 Mediated by CuCl**

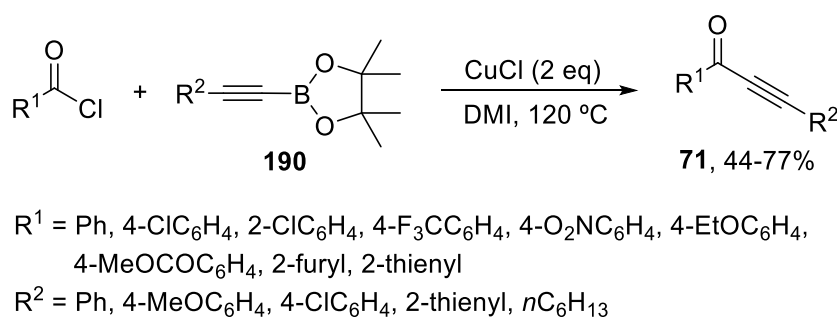

In conclusion, for the acylation of alkynylmetals with acyl chlorides, CuCl is the best catalyst, but high temperatures and aprotic high-boiling polar solvents are required to obtain the corresponding ynones.

2.2.2.5. Other Acylations of Terminal Alkynes. The coupling of acyl chlorides with terminal alkynes employing zinc dibromide has to be performed using 1.2 eq of this Lewis acid and the Hünig base (diisopropylethylamine, DIPEA) in acetonitrile at room temperature.²⁰⁴ Aromatic and aliphatic acetylenes reacted with aromatic and aliphatic acyl chlorides providing the corresponding ynones in good yields (Scheme 66). Using the

same reaction conditions but heating at 40-50 °C gave 2,5-disubstituted furans as the products.

Scheme 66. Coupling of Acyl Chlorides with Terminal Alkynes **127 Promoted by ZnBr₂**

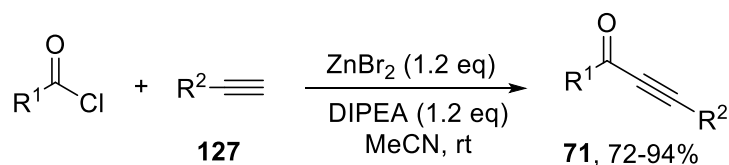

R¹ = Ph, 4-MeC₆H₄, 4-ClC₆H₄, *t*Bu, Et

R² = Ph, 4-MeC₆H₄, 4-MeOC₆H₄, *n*C₈H₁₇

Keivanloo and co-workers²⁰⁵ have described the same coupling using silica gel-supported zinc bromide as catalyst. The reaction took place under solvent-free conditions using 12 mol% of catalyst and 1.2 eq of DIPEA at room temperature. Aromatic and aliphatic acyl chlorides reacted not only with aryl acetylenes but also with alkyl acetylenes giving the corresponding ynones in yields (64-95%) similar to those obtained with the previous procedure.

Iron trichloride has been used as catalyst by Cheng and co-workers²⁰⁶ for the reaction of acyl chlorides with silylated terminal alkynes **139** (Scheme 67). This reaction takes place under very mild reaction conditions and 10 mol% loading of FeCl₃ in nitromethane as solvent furnishing the expected ynones in good yields.

Scheme 67. Coupling of Acyl Chlorides with Silylated Terminal Alkynes **139 Catalyzed by FeCl₃**

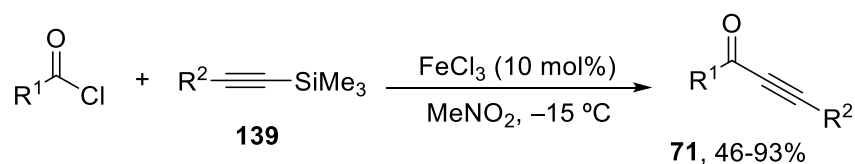

R¹ = Ph, 4-MeOC₆H₄, 2-MeC₆H₄, 3-MeC₆H₄, 4-MeC₆H₄, 2-FC₆H₄,

4-FC₆H₄, 4-BrC₆H₄, 4-ClC₆H₄, 2-thienyl, *n*Bu

R² = Ph, 2-MeC₆H₄, 3-MeC₆H₄, 4-MeC₆H₄, 4-ClC₆H₄, *t*Bu, Me

The La[N(SiMe₃)₂]₃-catalyzed cross-coupling of nitriles with terminal alkynes has been described by Zhou and co-workers.²⁰⁷ This acylation took place with 2.5 mol% of the La complex and 10 mol% of *n*BuNH₂ in toluene at room temperature giving the corresponding ynones in moderate yields (Scheme 68). A plausible mechanism for this reaction involves the formation of lanthanide acetylene **I** which after coordination of a molecule of nitrile and subsequent insertion into the La-C bond provided intermediate **II**. Final protonation of **II** by the amine affords **III** regenerating the catalyst.

Scheme 68. Coupling of Nitriles with Terminal Alkynes **127 Catalyzed by $\text{La}[\text{N}(\text{SiMe}_3)_2]_3$ and $n\text{BuNH}_2$**

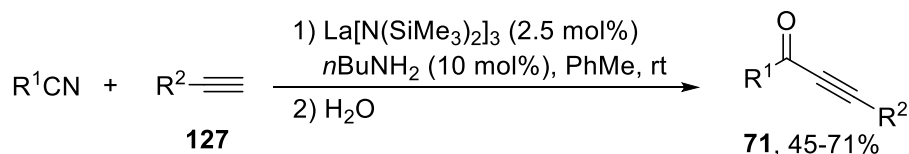

$\text{R}^1 = \text{Ph}, 4\text{-O}_2\text{NC}_6\text{H}_4, 4\text{-ClC}_6\text{H}_4, 4\text{-BrC}_6\text{H}_4, 4\text{-MeOC}_6\text{H}_4, n\text{Pr}, \text{NCCH}=\text{CH}$
 $\text{R}^2 = \text{Ph}, 4\text{-MeC}_6\text{H}_4, 4\text{-FC}_6\text{H}_4, 1\text{-cyclohexenyl}, n\text{Bu}, n\text{C}_6\text{H}_{13}, \text{TMS}$

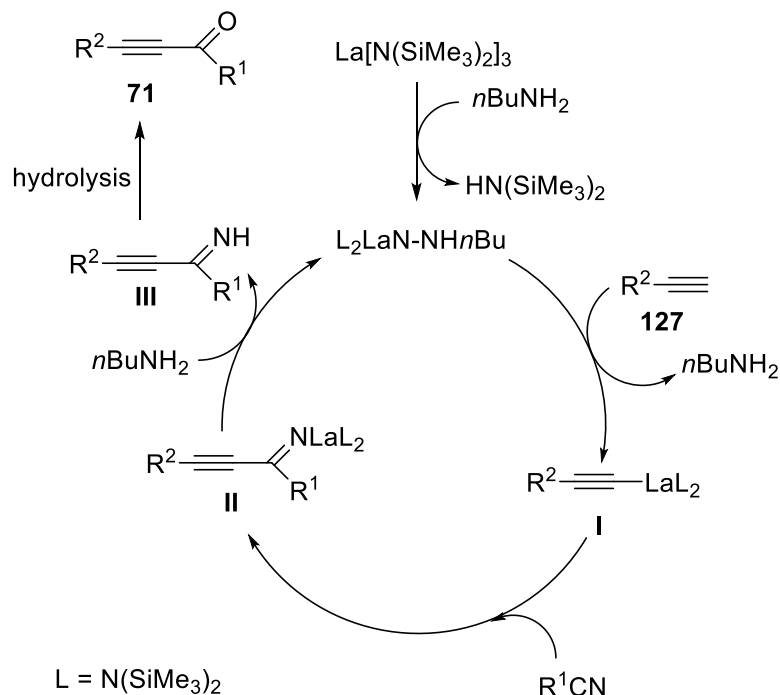

More recently Zhao and co-workers²⁰⁸ have described the same transformation but using a divalent amidate lanthanide (**191**) as catalyst. This reaction took place with 2.5 mol% loading under solvent-free conditions at room temperature affording, after hydrolysis, ynones in 28-96% yields (Figure 9).

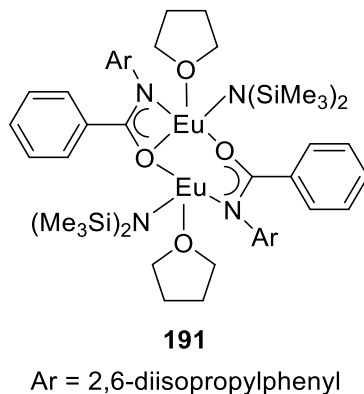

Figure 9. Lanthanide **191** used in the coupling of nitriles with terminal alkynes.

In conclusion, Lewis acids such as ZnBr_2 and FeCl_3 promote the coupling of acyl chlorides with alkynes, whereas $\text{La}[\text{N}(\text{SiMe}_3)_2]_3$ catalyzes the coupling of nitriles with terminal alkynes.

2.3. From Carbon Monoxide

Carbonylation reactions have been attracted the interest of chemists in the last two decades for the manufacture of bulk and fine chemicals.²⁰⁹⁻²¹⁸ The carbonylative Sonogashira synthesis of ynones is a three-component cross-coupling of aryl halides with terminal alkynes and CO in the presence of Et_3N under Pd-catalysis at 120 °C, which was described by Kobayashi and Tanaka in 1981.²¹⁹ This coupling has been performed under Pd- and Pd/Cu-catalysis either under homogeneous or heterogeneous catalysis.

2.3.1. Palladium- and Copper-Catalyzed Carbonylation of Terminal Alkynes. This three-component cross-coupling reaction has been carried out under anhydrous-anaerobic conditions and high CO pressures using palladium complexes and CuI as co-catalyst in the presence of an amine, typically Et_3N . The proposed mechanism involves two catalytic cycles; in cycle **A** copper acetylide is formed and then enters cycle **B** where transmetalation with an acylpalladium intermediate occurs and forms an alkynyl-acyl palladium species able to undergo reductive elimination and afford the ynone (Scheme 69).

Scheme 69. Proposed Mechanism for the Pd and Cu Catalyzed Carbonylative Sonogashira Reaction

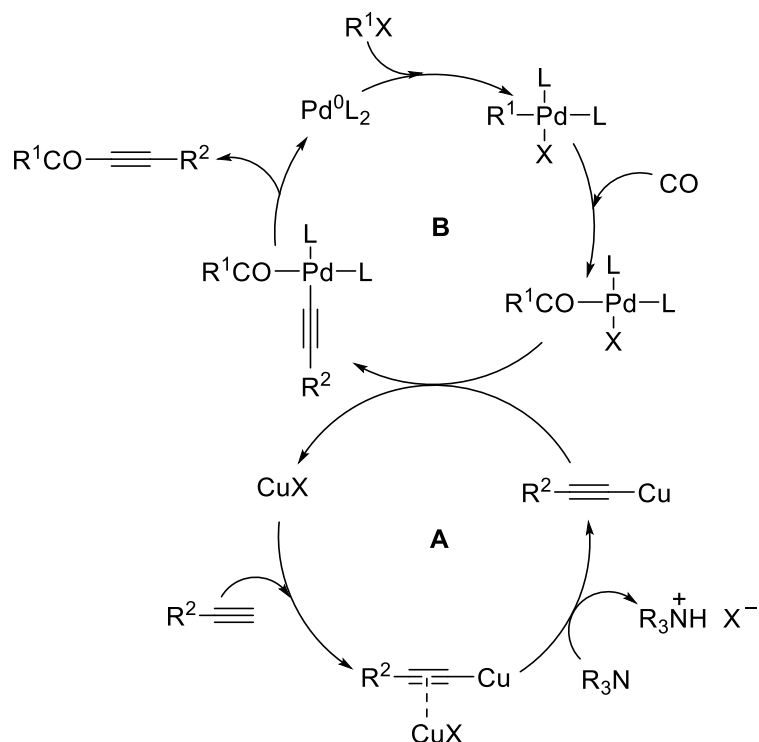

Mohamed Ahmed and Mori performed the former reaction under mild conditions, at room temperature and 1 bar CO using 1 mol% Pd(PPh₃)₂Cl₂ and 0.5 M aqueous ammonia in THF.^{220,221} The corresponding ynones **71** were obtained in good yields using aryl iodides and alkyl and aryl terminal alkynes (Scheme 70).

Scheme 70. Carbonylative Sonogashira Coupling of Terminal Alkynes **127 and Aryl Iodides**

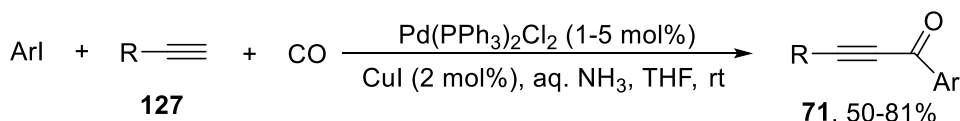

Ar = Ph, 4-MeOC₆H₄, 2-MeOC₆H₄, 3-MeOC₆H₄, 4-MeC₆H₄, 4-MeCOC₆H₄,
4-ClC₆H₄, 1-naphthyl, 2-H₂NC₆H₄, 4-IC₆H₄
R = Ph, nC₆H₁₃, tBu, HO(CH₂)₂, HO(CH₂)₃

In the case of alkyl substituted alkynes, 2 mol% of CuI and 5 mol% of the Pd complex must be used. The same group has performed the four-component synthesis of pyrazoles and oxazoles using methylhydrazine and hydroxylamine, respectively.²²²

Müller and co-workers have performed the carbonylative alkynylation of 3-iodoindole derivatives **192** with (trimethylsilyl)acetylene using 5 mol% of Pd(dppf)Cl₂ as well as 2 mol% of CuI along with 1 eq of Et₃N in THF at room temperature (Scheme 71).²²³ The resulting ynones **193** have been obtained in moderate yields and were applied to the synthesis of pharmaceutical active meridianins and derivatives by *in situ* reaction with guanidine.

Scheme 71. Carbonylative Sonogashira Coupling of (Trimethylsilyl)acetylene with 3-Iodoindoles **192**

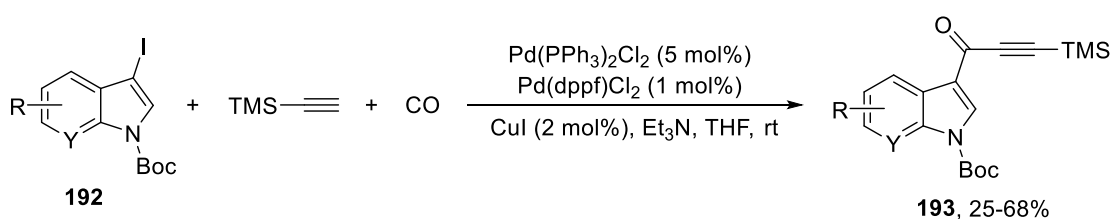

R = H, Br
Y = CH, N

Aryl ferrocenylethynyl ketones **147** have been prepared by reaction of aryl iodides with ethynylferrocene **146** by carbonylative coupling using 4 mol% of Pd(PPh₃)₄ and CuI with K₂CO₃ as a base in toluene at 80 °C (Scheme 72).²²⁴ However, the reaction with 2-iodophenols under the same reaction conditions afforded 2-ferrocenyl-4*H*-chromen-4-ones in 74-80% yield.

Scheme 72. Carbonylative Sonogashira Coupling of Ethynylferrocene (146**) with Aryl Iodides**

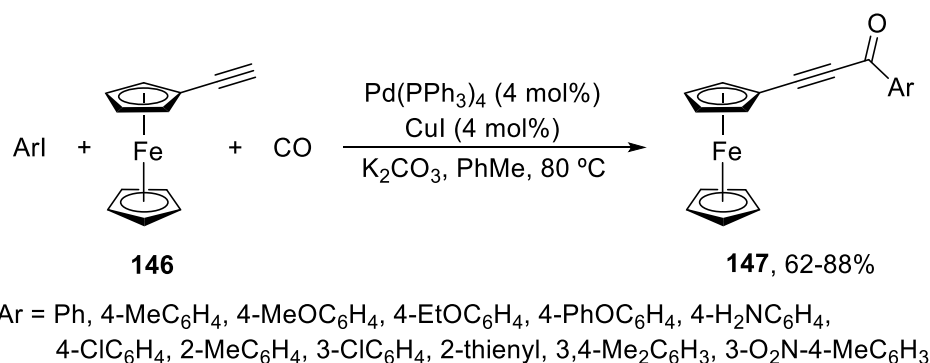

Carbonylative coupling of iodoferrocene **194** with terminal alkynes **127** under Pd(PPh₃)₂Cl₂ (10 mol%) and CuI (1 or 2 mol%) catalysis took place using Et₃N (1 eq) and THF at 60 °C and 1 bar of CO, giving ynones **195** in variable yields (Scheme 73).²²⁵ These ynones have been transformed into the corresponding pyrazoles and pyrimidines by reaction with hydrazines and guanidines, respectively (see Section 3.1.3.1.3).

Scheme 73. Carbonylative Sonogashira Coupling of Iodoferrocene (194) with Terminal Alkynes 127

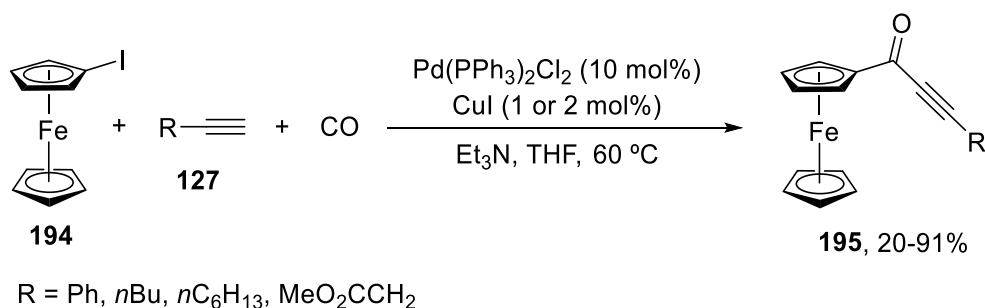

Mo(CO)₆ has been used as source of CO for the four-component carbonylative generation of pyrazoles and pyrimidines by *in-situ* formation of ynones.²²⁶ The reaction took place when aryl iodides and bromides were exposed to 1.5 eq of Mo(CO)₆, Pd(OAc)₂ (5 mol%), CuI (2 mol%) and Cs₂CO₃ in a 1:1 mixture of toluene and acetonitrile at 80 °C.

Symmetrical 1,3-diarylalkynones (**71**) have been prepared by carbonylative and non-carbonylative coupling reactions of propiolic acid with aryl iodides in the presence of 6 eq of Et₃N in acetonitrile at 80 °C under a CO atm of 6 bar.²²⁷ The synthesis was performed with 5 mol% of Pd(PPh₃)₂Cl₂ and 10 mol% of CuCl, which is crucial for the carbonylative process (Scheme 74). The reaction starts with the arylation of propiolic acid with complex **I**, giving a new complex (**II**), which by reductive elimination yields aryl propiolate **III**: this is the cycle for the non-carbonylative coupling. In the carbonylative cycle, complex **I** suffers carbonylation to give an acyl palladium complex (**IV**) which by reaction with compound **III**, after decarboxylation, gave intermediate **V**. Final reductive elimination of **V** gave as expected ynone **71**.

Scheme 74. Carbonylative and Non-Carbonylative Sonogashira Couplings of Aryl Iodides with Propiolic Acid

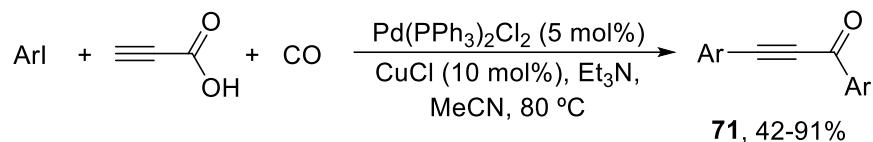

Ar = Ph, 4-MeC₆H₄, 3-MeC₆H₄, 2-MeOC₆H₄, 4-MeOC₆H₄, 4-BrC₆H₄, 4-ClC₆H₄, 4-FC₆H₄, 4-F₃CC₆H₄, 4-AcC₆H₄, 4-MeO₂CC₆H₄, 4-PhC₆H₄, 1-naphthyl, 2-thienyl, 3-Py, PhCH=CH

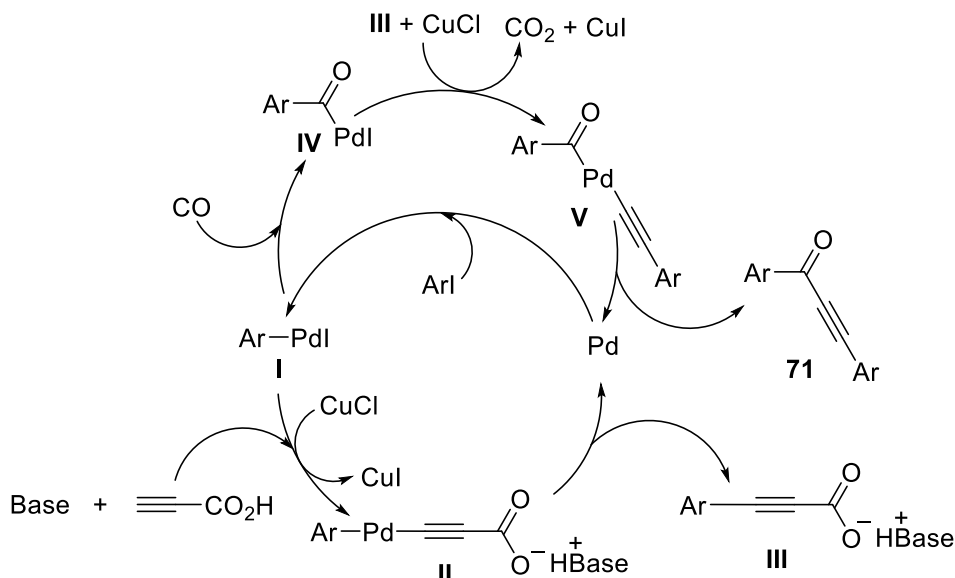

In conclusion, the Pd and Cu-catalyzed carbonylative Sonogashira coupling can be carried out at CO atmospheric pressure at relatively low temperatures especially in aqueous ammonia using Pd(PPh₃)₂Cl₂ and CuI as catalysts.

2.3.2. Palladium-Catalyzed Carbonylation of Terminal Alkynes. Initial studies on the palladium-catalyzed carbonylative Sonogashira coupling of aryl iodides required high CO pressure and temperatures.²²⁸⁻²³² The Pd-catalyzed carbonylation of terminal alkynes in the presence of amines requires anhydrous and anaerobic conditions and relative high CO pressure. This process has been proposed to take place by formylation of a η^2 -(R²C≡CH)PdCOR¹ complex, which reduces the pK_a of the alkyne proton and therefore it can be deprotected by Et₃N giving the alkynyl complex. After final reductive elimination the corresponding ynone (**71**) can be formed (Scheme 75).

Scheme 75. Possible Mechanism for the Pd-Catalyzed Carbonylative Sonogashira Coupling Reaction

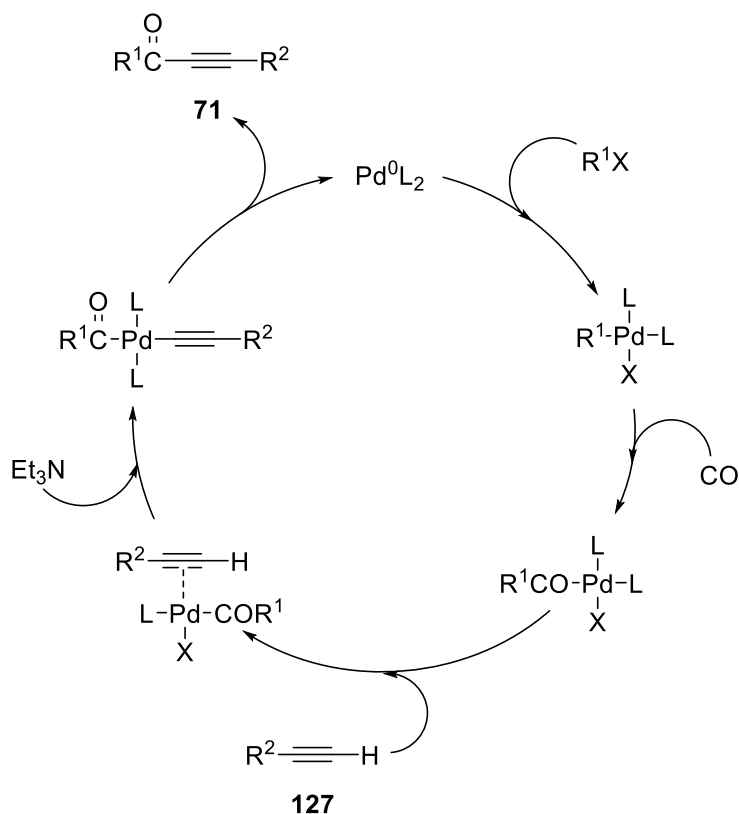

However, when iodonium salts were used, the reaction can be performed with only 0.2 mol% of $\text{Pd}(\text{OAc})_2$ and 1 bar of CO in aqueous DMF at room temperature.²³³ Ma and co-workers²³⁴ applied the coupling of iodonium iodide **196** to perform arylation of aromatic, aliphatic and heterocyclic terminal alkynes giving ynones **197** under copper-free conditions (Scheme 76).

Scheme 76. Carbonylative Cu-Free Sonogashira Coupling of Iodonium Iodide 196 with Terminal Alkynes 127

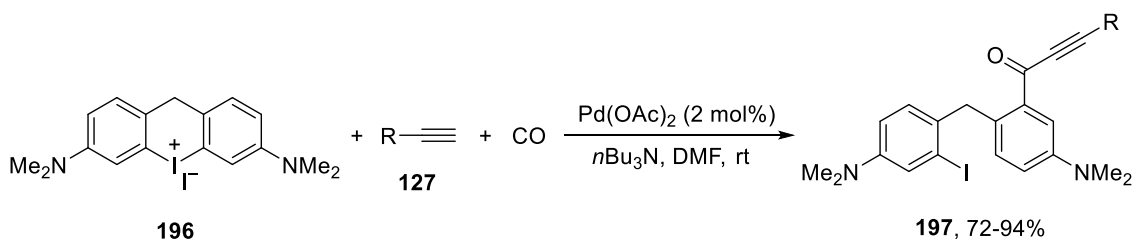

R = Ph, 4- BrC_6H_4 , 4- MeOC_6H_4 , $n\text{C}_5\text{H}_{11}$, MeOCH_2 , ferrocenyl, 1-benzotriazolylmethyl

Water has been used as solvent for the Pd-catalyzed carbonylative Sonogashira reaction of aryl iodides with alkynes under Cu-free conditions. This process has been carried out with aromatic and aliphatic alkynes with a CO balloon and Et_3N as base at room temperature affording ynones mostly in good yields (Scheme 77).²³⁵ This process was also applied to the synthesis of flavones using 2-iodophenols. Furthermore, the synthesis of ferrocenylethynyl ketones **147** was performed using water as solvent under Cu-free conditions.²³⁶ This carbonylative alkylation has been carried out under PdCl_2

(5 mol%) and PPh₃ (10 mol%) catalysis at 1 atm of CO using sodium dodecyl sulfate (SDS) as surfactant and Et₃N (3 eq) as a base. The resulting ynones (**147**) were obtained in modest to good yields (10-84%). However, Ryu and co-workers used the ionic liquid [bmim]PF₆ as solvent for the carbonylation of aryl iodides at 120 °C and 20 atm using 1 mol% of Pd(PPh₃)₂Cl₂ affording the resulting ynones in 76-82% yield.²³⁷ This coupling can also be catalyzed by the corresponding N-heterocyclic carbene complex in a microflow system at low CO pressure (5 atm) than in the conventional batch method.²³⁸

Scheme 77. Carbonylative Cu-Free Sonogashira Coupling of Aryl Iodides with Terminal Alkynes **127 in Water**

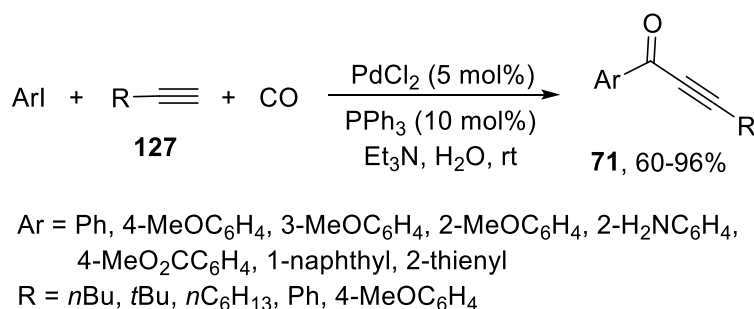

When phosphites were used as ligands, the carbonylation of aryl iodides in toluene and in an ionic liquid such as [bmim]PF₆ took place at 1 bar of CO. The reaction was performed with 1 or 2 mol% of PdCl₂[P(OPh₃)₃]₂ and 1 eq of Et₃N at 80 °C for aryl alkynes and aryl iodides providing the corresponding ynones **71** in moderate yields (24-62%).²³⁹

Nicolaou and co-workers have described, in the total synthesis of the natural product biyouyanagin A, a palladium-catalyzed carbonylative insertion cascade for the preparation of hyperolactone C.²⁴⁰ Alkyne **198** was allowed to react with iodobenzene using 5 mol% of Pd(PPh₃)₂Cl₂ and CO (200 psi) in Et₃N at 100 °C, which gave ynone **199** in good yield (Scheme 78).

Scheme 78. Carbonylative Cu-Free Sonogashira Coupling of Iodobenzene with Alkyne **198**

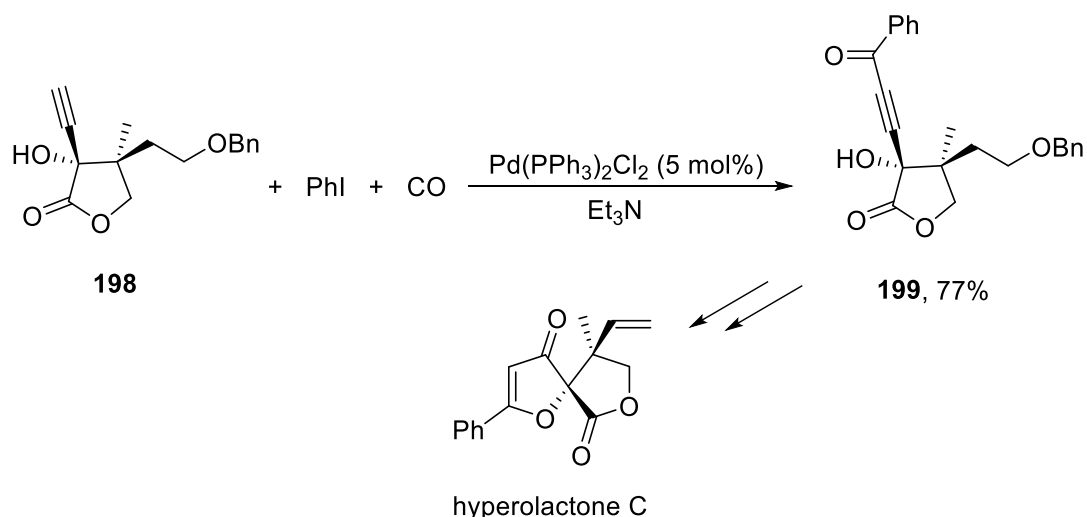

A microwave-assisted carbonylative Sonogashira reaction followed by annulation of alkyl and aryl acetylenes with 2-iodophenol allowed the preparation of flavones by *in-situ* formation of the corresponding ynones.²⁴¹ This process was carried out with 15 mol% of Pd₂(dba)₃ and 3 mol% of the phosphine 1,3,5,7-tetramethyl-2,4,8-trioxa-6-phenyl-6-phosphadamantane (PA-Ph) at 1 atm of CO, using DBU as base in DMF at 50 °C. Flavones have been prepared by Yang and Alper²⁴² using ligand-free carbonylation reactions of 2-iodophenols with terminal alkynes in ionic liquids. In this case 5 mol% of PdCl₂, 3 eq of Et₃N and [nC₁₄H₂₉(nC₆H₁₃)₃P]⁺Br⁻ as ionic liquid under atmospheric pressure of CO at 110 °C, gave the best results. 2-Iodoanilines can give the corresponding ynones **200** in moderate to good yields by reaction with terminal alkynes using 1 mol% of Pd(dppp)Cl₂, 4 eq of Et₃N, 5 bar of CO in toluene at 80 °C (Scheme 79).²⁴³ By changing the carbonylation reaction conditions either indoxyls or 4-quinolones can be selectively prepared.

Scheme 79. Carbonylative Cu-Free Sonogashira Coupling of 2-Iodoanilines with Terminal Alkynes 127

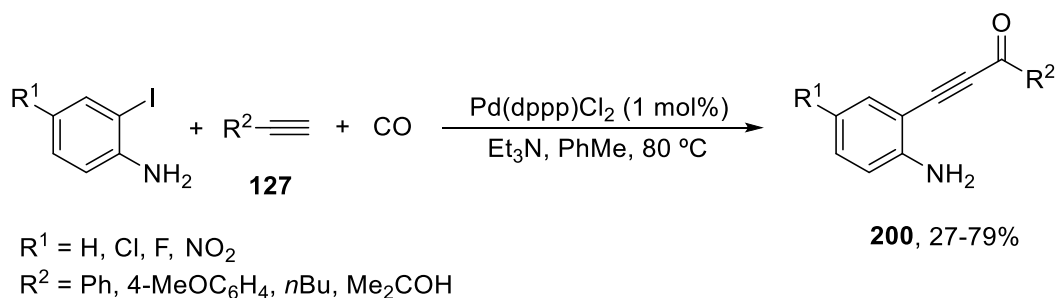

Related ynones **202** have been synthesized by carbonylation of 2-amino-3-(2-trimethylsilyl)-5-methylpyridine **201** with aryl iodides (Scheme 80).²⁴⁴ The resulting pyridylamine-derived ynones are precursors of disubstituted [1,8]naphthyridines.

Scheme 80. Carbonylative Cu-Free Sonogashira Coupling of 2-Amino-3-(2-trimethylsilyl)-5-methylpyridine 201 with Aryl Iodides

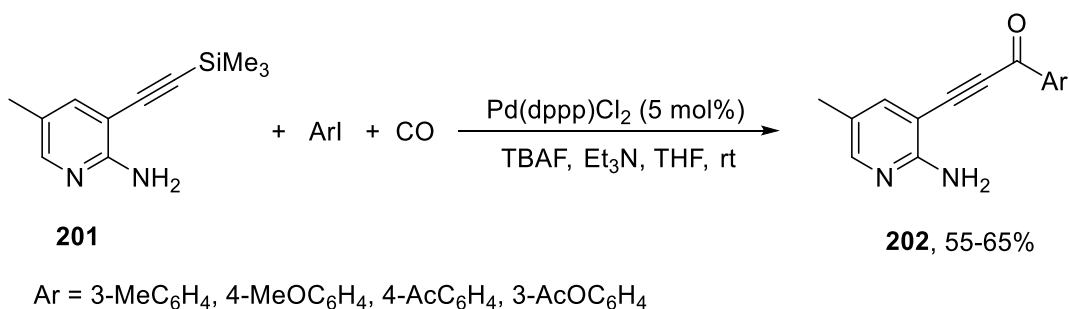

Ryu and co-workers²⁴⁵ have prepared ynones in good yields by light-induced Pd-catalyzed carbonylation of aryl iodides with terminal alkynes. The coupling has been performed with 5 mol% of PdCl₂(PPh₃)₂ and Et₃N (1.2-1.4 eq) in 10:1 benzene/water at 45 atm of CO and irradiation with a 500 W xenon lamp through Pyrex (Scheme 81). This process allows the carbonylation of iodoalkanes giving the corresponding aliphatic ketones through the subsequent formation of an alkyl and acyl radical.

Scheme 81. Carbonylative Light-Induced Pd-Catalyzed Sonogashira Coupling of Iodoalkanes with Terminal Alkynes **127**

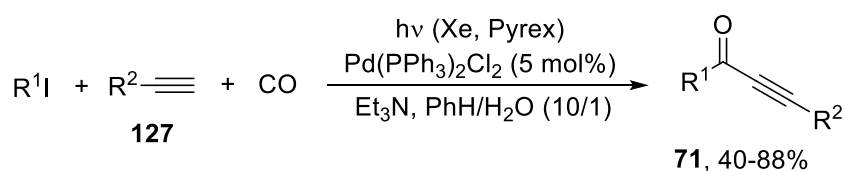

R¹ = Cl(CH₂)₈, MeO₂C(CH₂)₃, TBSO(CH₂)₄, nC₆H₁₃CHMe, Ph(CH₂)₂CHMe, Cy, nBu₂CH, 1-adamantyl
 R² = Ph, nC₆H₁₃, TMS

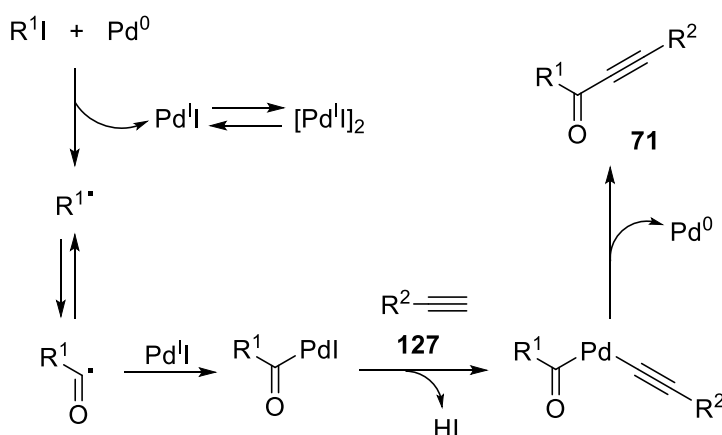

Beller and co-workers²⁴⁶ have described an efficient carbonylative coupling of aryl bromides with aryl acetylenes **127** using 2 mol% of [(cinnamyl)PdCl]₂, 6 mol% of nBuPAD₂, and K₂CO₃ in DMF. The coupling appeared to be challenging and required 10 bar of CO and 100 °C to form ynones **71** in moderate to good yields (Scheme 82).

Scheme 82. Carbonylative Cu-Free Sonogashira Coupling of Bromoarenes with Terminal Acetylenes **127**

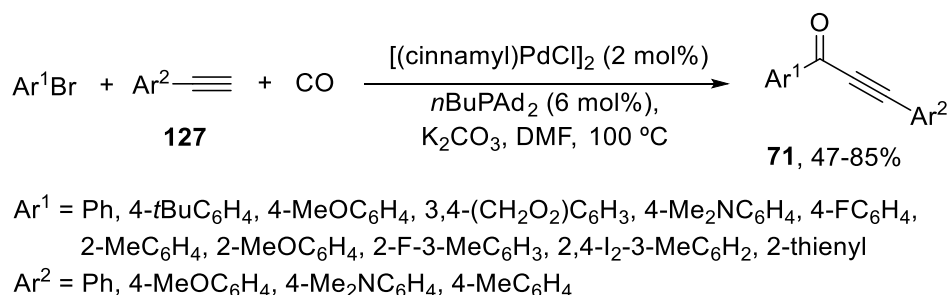

Beller's group has shown that benzyl chlorides can undergo carbonylative coupling with aromatic and aliphatic terminal acetylenes **127** using 2 mol% of PdCl₂(PPh₃)₂ and triphenyl phosphite as ligand.²⁴⁷ The reaction has to be performed at 10 bar of CO with 2 eq of Et₃N in toluene at 100 °C, but the corresponding ynones (**71**) were only obtained in modest to good yields (Scheme 83). When benzyl acetylenes were used instead of aryl acetylenes, furan-2(3*H*)-ones were formed in moderate yields.^{247,248}

Scheme 83. Carbonylative Cu-Free Sonogashira Coupling of Benzyl Chlorides with Terminal Alkynes **127**

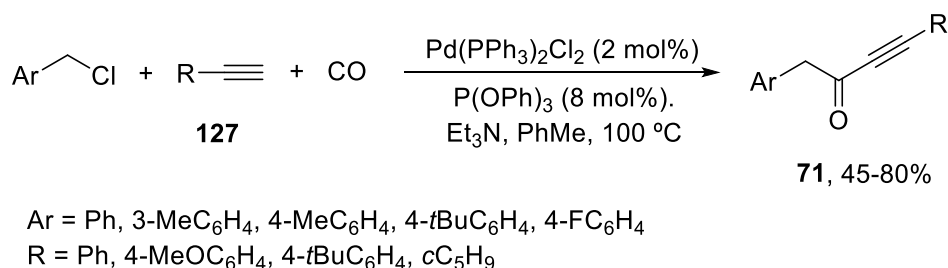

Beller and co-workers have reported the carbonylative coupling using triflates.²⁴⁹ This process occurred under conditions similar to those applied for aryl bromides,²⁴⁷ using 1 mol% of [(cinnamyl)PdCl]₂, XantPhos (2 mol%) as ligand, Et₃N (2 eq) as a base and 10 bar of CO in toluene at 110 °C. Aryl and substituted alkenyl triflates gave the corresponding ynones in modest to good yields (50-83%). These substrates have been used for the synthesis of furan-2-ones.²⁴⁸

Skrydstrup and co-workers²⁵⁰ have reacted aryl and heteroaryl bromides with aliphatic and aromatic alkynes and applied near stoichiometric amounts of CO, generated in a two-chamber reactor CO_{gen}.²⁵¹ This general procedure was performed with 5 mol% of PdCl₂, 5 mol% of XantPhos, and 3 eq of Et₃N in dioxane at 80 °C giving the expected ynones in 52-97% yield. The method was used to synthesize the corresponding ¹³C-labeled pyrimidines employing ¹³C labeled CO and amidines.²⁵¹

Arenediazonium salts, generated *in situ* by diazotization of anilines, are also useful reagents for the carbonylative Sonogashira coupling of aryl and alkyl alkynes **127**.²⁵² This process was catalyzed by 2 mol% of Pd(OAc)₂ and 6 mol% of tri(2-furyl)phosphine (TFP)

under 10 bar of CO in a 10:1 mixture of THF and DMSO (Scheme 84). The arenediazonium salts are able to undergo oxidative addition to Pd⁰ giving the species **I**, which after insertion of CO provides the corresponding acyl palladium complex **II**. In the presence of acetate, the alkyne is deprotonated giving an acyl alkynyl Pd-intermediate **III**, which after reductive elimination affords the final ynone **71** and regenerates Pd⁰.

Scheme 84. Diazotization/Carbonylative Cu-Free Sonogashira Coupling with Terminal Alkynes 127

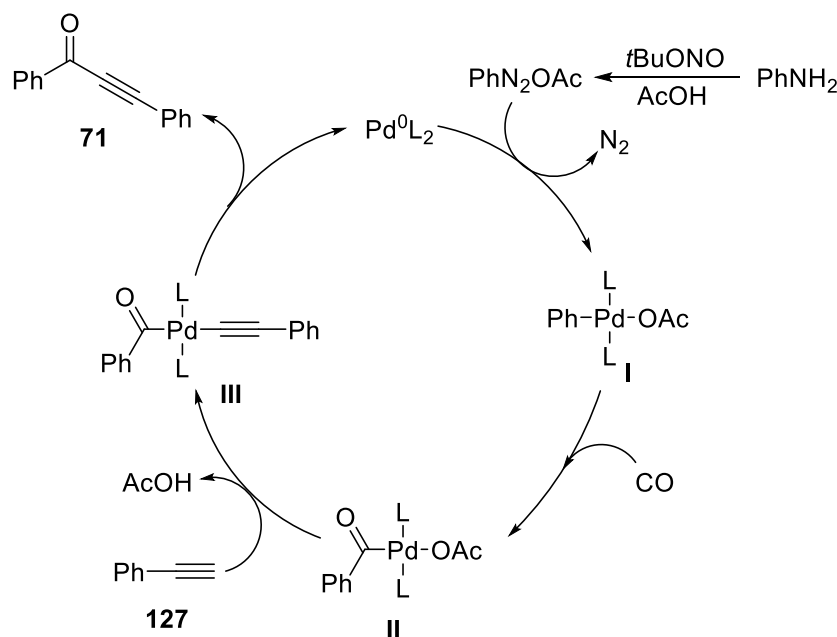

Aryl triazenes have been also transformed into arenediazonium salts in the presence of methanesulfonic acid as additive.²⁵³ The corresponding carbonylative Sonogashira coupling took place with aryl and alkyl terminal alkynes giving rise to ynones in moderate to good yields (31-87%). The reaction was performed with 3 mol% of Pd(OAc)₂, 6 mol% of P(*o*-Tol)₃, and 1.1 eq of MeSO₃H under 20 bar of CO in THF at 70 °C.

Procedures with low CO pressure have been described, using Pd and *N*-heterocyclic carbene (NHC) complexes as catalysts. Li and co-workers²⁵⁴ reported that a benzimidazolin-2-ylidene/co-ligand Pd(II) complex [PdBr₂(*i*Pr-bimy)L] **203** (Figure 10) is a very active catalyst (0.5 mol%) for the carbonylative Sonogashira coupling of 2-iodophenol with aromatic and aliphatic alkynes. This carbonylation took place at 4 bar of CO with Et₂NH (1 eq) as base in DMF at 80 °C affording flavones in 25-98% yield. Sankararaman and co-workers²⁵⁵ have employed 5 mol% of the Pd-carbene **204** (Ar = *o*-Tol; Figure 10) derived from 1,2,3-triazol bearing *o*-tolylphosphine as ligand in the carbonylative alkynylation of aryl iodides using 1 bar of CO and 3 eq of Et₃N in toluene at 80 °C. The corresponding 1,3-diarypropynones, containing either substituted phenyl groups or fluorophoric 1-pyrenyl, 3-carbazolyl, and 1-naphthyl groups, were prepared in good to excellent yields (59-94%). The Pd catalyst was recovered and reused up to three runs by absorbing the *cis*-(Tz)PdCl₂(PPh₃)₃ **204** (Ar = Ph) precatalyst on silica gel. Under

1 bar of CO, several bifunctional ligands that contain phosphines and Lewis-acidic phosphonium sites for $\text{PdCl}_2(\text{MeCN})_2$, such as **205** (Figure 10), were able to stabilize the Pd-acyl intermediates.²⁵⁶ The carbonylative Sonogashira reaction of aryl iodides with terminal alkynes took place with 1.5 eq of Et_3N in DMF at 90 °C. The phosphonium cation can form secondary bonds with the oxygen atom of the C=O group. Dimeric benzophenone-oxime-derived palladacycle was initially used by Sugi and co-workers²⁵⁷ in the alkoxy carbonylation of aryl iodides. Recently, Bhanage and co-workers²⁵⁸ have used palladacycle **172**²⁵⁹ for the carbonylative Sonogashira coupling of aryl iodides with aromatic and aliphatic alkynes at 2 bar of CO. The reactions were performed with 0.005 mol% of Pd, K_2CO_3 (2 eq), and PEG-600 at 100 °C and this gave the corresponding ynones in good yields (69-93%). This catalyst showed a higher efficiency than $\text{Pd}(\text{OAc})_2$ and $\text{PdCl}_2(\text{PPh}_3)_2$. Poly(ethylene glycol), an environmentally benign solvent, allowed recycling of the palladacycle up to four times.

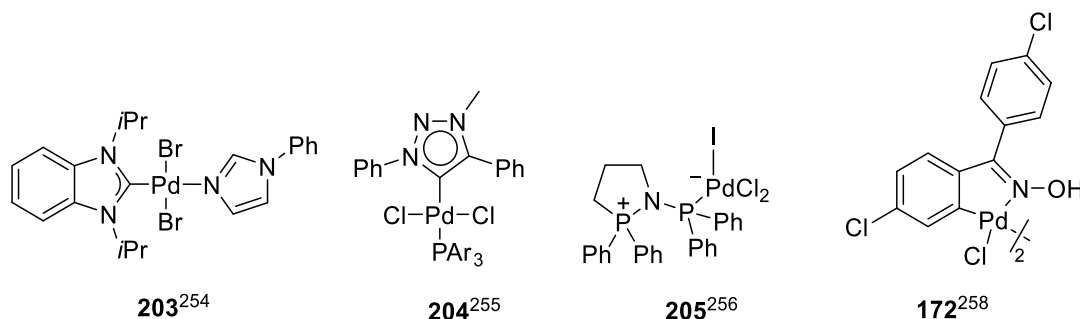
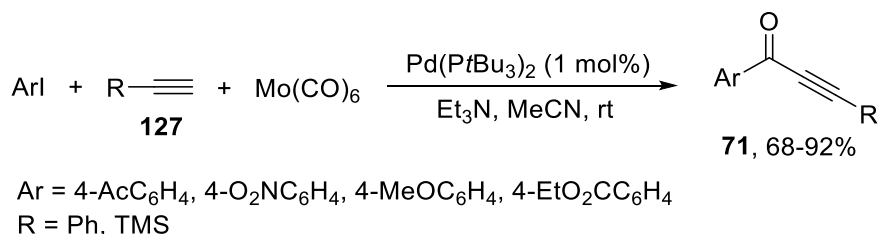

Figure 10. Palladium complexes used as catalysts for the carbonylative Sonogashira coupling of terminal alkynes **125**.

Copper-free carbonylative Sonogashira coupling of aryl iodides to alkynes using $\text{Mo}(\text{CO})_6$ as CO source has been described by Tizuka and Kondo.²⁶⁰ The reaction took place under mild reaction conditions (room temperature) with $\text{Pd}(\text{tBu}_3\text{P})_2$ and Et_3N in acetonitrile, which is an efficient solvent for CO release (Scheme 85). These reaction conditions allowed a four-component synthesis of pyrazoles.

Scheme 85. Carbonylative Cu-Free Sonogashira Coupling of Aryl Iodides with Terminal Alkynes **127 Using $\text{Mo}(\text{CO})_6$ as CO Source**



Due to toxicity and safety problems associated with the use of CO, Skrydstrup and co-workers²⁶¹ used silacarboxylic acids as easy-to-handle and air-stable CO precursors. $\text{MePh}_2\text{SiCO}_2\text{H}$ is such a compound, and when treated with KF, CO is formed and can

participate in several carbonylative couplings. As a representative example of application of this methodology, 4-iodoanisole and 1-hexyne were treated with Pd(PPh₃)₂Cl₂ as catalyst, Et₃N as base and water as solvent at room temperature and afforded the corresponding ynone in 82% isolated yield.

Carbonylative Sonogashira coupling reactions was recently performed using aryl formates (**206**) as both reagents and CO source by Beller, Wu and co-workers.²⁶² In the presence of a base, aryl formates generates CO and phenol, which in the presence of nonafluorobutanesulfonyl fluoride (NfF) suffers sulfonylation to give the corresponding aryl nonaflates. These compounds can further act as pseudohalide able to react with Pd(0) by oxidative addition giving intermediate **I**, which enters in the catalytic cycle. The coupling with aromatic terminal alkynes occurred with Pd(OAc)₂ (5 mol%), dppf (7.5 mol%) and 5 eq of Et₃N in acetonitrile at 80 °C affording ynones in good yields (Scheme 86).

Scheme 86. Carbonylative Cu-Free Sonogashira Coupling of Aryl Formates 206 with Terminal Alkynes 127

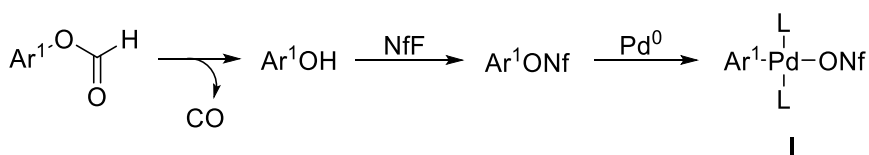
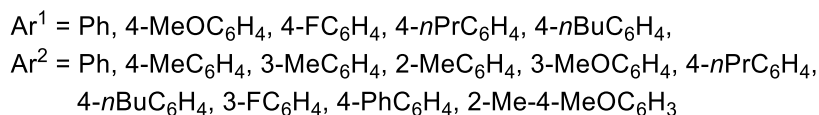
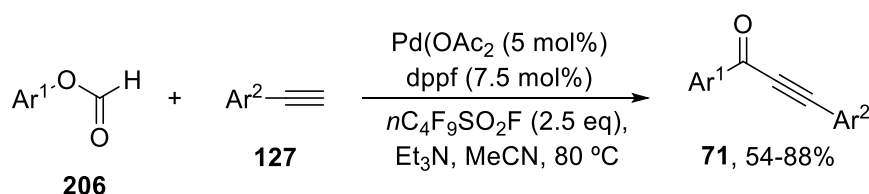

Hansen and Ulven have reported that oxalyl chloride reacts with aqueous NaOH giving CO.²⁶³ For the carbonylative Sonogashira coupling reaction Gracza and co-workers²⁶⁴ used oxalyl chloride and zinc for the reduction to CO. The carbonylation was applied to the reaction of 4-iodoanisole with 1-hexyne and phenylacetylene and this gave the corresponding ynones in 63 and 61% yield, respectively (Scheme 87).

Scheme 87. Carbonylative Cu-Free Sonogashira Coupling of 4-Iodoanisole with Terminal alkynes 127 Using Oxalyl Chloride and Zn

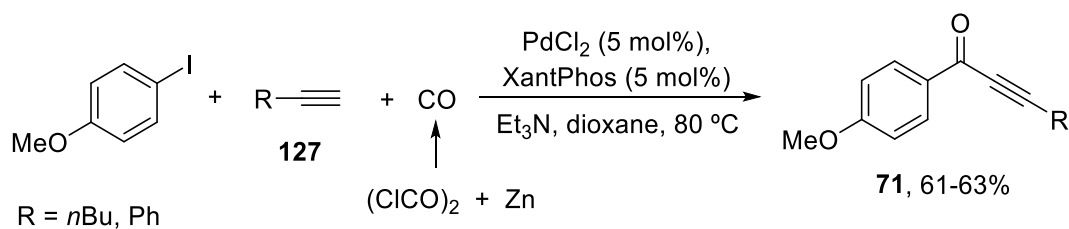

Pd-catalyzed carbonylative Sonogashira coupling reactions under heterogeneous conditions have been performed with Pd/C under Cu- and phosphine-free conditions.²⁶⁵ Aryl iodides are carbonylated with CO (20 bar) and aromatic and aliphatic terminal alkynes in the presence of Et₃N (3 eq) in toluene at 130 °C using 5% Pd/C (4 mg/mmol). The resulting ynones were obtained generally in high yields (63-96%) and the Pd/C was recovered and reused up to three times. Under CO pressure of one atmosphere, the reaction was performed using the mesoporous material MCM-41-supported phosphine palladium(0) complex [MCM-41-2P-Pd(0)] **207** (Figure 11).²⁶⁶ Aromatic and aliphatic alkynes reacted with aryl iodides and CO (1 bar) with 5 mol% of Pd catalyst and Et₃N at room temperature affording the expected ynones in 45-90% yield. Magnetically separable Pd NPs,²⁶⁷ prepared by impregnation of Pd/Fe₃O₄ (0.2 mol%), have been used in the coupling of aryl iodides with aromatic alkynes at 20 bar pressure of CO and 2.4 eq of Et₃N in toluene at 130 °C giving ynones in 71-95% yield. The catalyst could be reused seven times with a slight loss of activity for the carbonylative coupling of iodobenzene with phenylacetylene. A cross-linked polymer of divinylbenzene with 3-*n*-butyl 1-vinylimidazolium iodide was treated with Pd(OAc)₂ in DMSO affording P(DVB-IL)-Pd **208**²⁶⁸ (Figure 11). This heterogeneous catalyst was employed in the carbonylative Sonogashira coupling of aryl iodides with aromatic alkynes using 0.5 mol% of Pd, Et₃N and water at 130 °C and 30 bar of CO, affording ynones in 81-94% yield. This catalyst could be reused five times with a decrease of 90-84% yield for the reaction of iodobenzene with phenylacetylene.

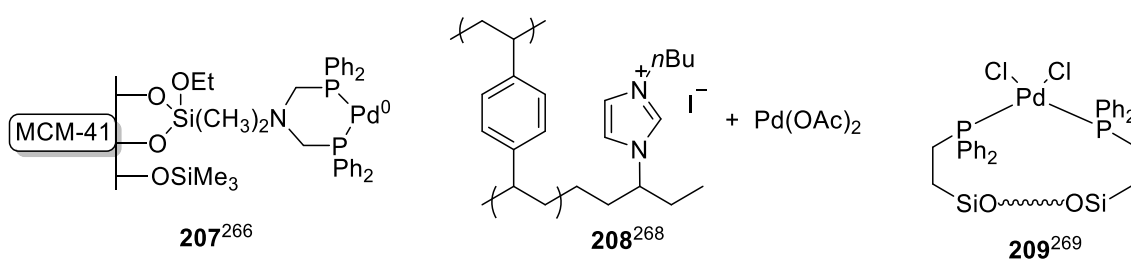

Figure 11. Selected heterogeneous Pd-supported catalysts for the carbonylative Sonogashira coupling reaction.

Phosphino-palladium complexes anchored to mesoporous silica have been used as heterogeneous catalysts in the carbonylative Sonogashira coupling.²⁶⁹ The reaction has been performed with *o*-iodoanilines and aromatic terminal alkynes **127** in the presence of 0.1 mol% of the palladium hybrid catalyst Pd(PPh₂)₂@SBA-15 (**209**), 2.5 eq of Et₃N and CO (20 bar) in anisole at 80 °C. The corresponding ynones **200** were obtained in 58-81% yield. Leaching-redeposition studies showed that leaching took place in the final

palladium-decoordination from grafted ligand. Recycling experiments were performed and during five cycles the yield dropped from 87 to 39%.

PdCl₂ supported on a metal-organic framework (MOF) ZrMOF-BIPY, prepared from ZrCl₄ and 2,2'-bipyridine-5,5'-dicarboxylic acid,²⁷⁰ Pd(II)@ZrMOF-BIPY has been used in the carbonylative Sonogashira coupling under atmospheric pressure of CO.²⁷¹ Aryl iodides reacted with aryl and alkyl acetylenes when treated with Pd(II)@ZrMOF-BIPY (1 mol% Pd loading) and Cs₂CO₃ (1 eq) in DMF at 100 °C, giving ynones in 62-98% yields. The catalyst was recycled with negligible metal leaching and reused five times without apparent loss of activity. Pd(PPh₃)₂Cl₂ in a mixture of water and PEG-2000 has shown efficient catalytic activity in the carbonylative Sonogashira coupling of aryl iodides with aliphatic and aromatic terminal alkynes.²⁷² The reaction occurred under mild conditions at 25 °C and 1 bar of CO, with 2 eq of Et₃N, providing ynones in good yields (57-95%). Thermoregulated liquid/liquid catalytic (TRPTC) systems are also an attractive alternative that combines high activity of homogeneous catalysis with the simplicity of catalyst separation.²⁷³ The ligand Ph₂P(CH₂CH₂O)_nMe (n = 22) with phase-transfer properties and PdCl₂ is an efficient and recyclable catalytic medium (2.5 mol%) for the carbonylative Sonogashira coupling of aryl iodides and aromatic and aliphatic terminal alkynes at 1 atm of CO, Na₂CO₃ (1 eq) as base and water as solvent at 80 °C.²⁷⁴ The resulting ynones were obtained in 33-91% yield and the aqueous phase containing the catalyst was reused for four cycles in the coupling of phenyl iodide and phenylacetylene with yields decreasing from 90 to 84%.

Palladium anchored on a primary amine-functionalized K-10 montmorillonite Pd(II)APTES@K10 has been used as heterogeneous catalyst in the carbonylative Sonogashira coupling of aryl iodides with aryl acetylenes.²⁷⁵ The reaction was performed at 4 bar of CO and 2 eq of Et₃N in DMF at 80 °C, leading to ynones in 60-92% yield. The catalyst could be recovered and reused up to four cycles, the yield varying from 94 to 88%. This catalyst has been employed in the synthesis of aurones and flavones using *o*-iodophenol.²⁷⁶

In conclusion, concerning the use of CO as carbonylative agent under Pd-catalyzed homogeneous conditions, the use of water as solvent and PdCl₂ and PPh₃ makes it possible to work at room temperature with a CO balloon for aryl iodides. Under heterogeneous conditions, a simple recyclable PdCl₂(PPh₃)₂ in a mixture of PEG-2000 and water at room temperature and 1 bar of CO can be used for the general synthesis of ynones.

2.3.3. Other Carbonylation Reactions. Bhanage and co-workers performed the only example of copper-catalyzed carbonylative coupling of aryl iodides with aliphatic and aromatic terminal alkynes **127** using 5 mol% of copper(II) bis(2,2,6,6-tetramethyl-3,5-heptadioate) (TMHD) as catalyst.²⁷⁷ The reaction was performed under Pd- and phosphine-free conditions working at 20 bar of CO and using 3 eq of Et₃N in toluene at 90 °C providing ynones **71** in moderate to good yields (Scheme 88).

Scheme 88. Cu-Catalyzed Carbonylative Sonogashira Coupling of Aryl Iodides with Terminal Alkynes **127**

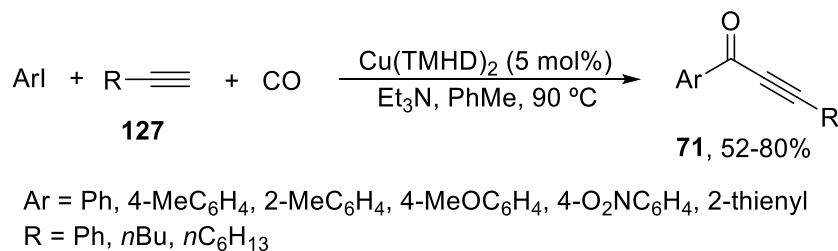

Bäckvall and Volla have described a palladium-catalyzed oxidative domino carbocyclization-alkynylation of enallenes **210** giving ynones **211** in good yields (Scheme 89).²⁷⁸ The reaction took place using 5 mol% of Pd(TFA)₂ and 2 eq of 1,4-benzoquinone in 1,2-dichloroethane at room temperature under 1 atmosphere of CO. The proposed mechanism involves first the formation of a π -complex (**I**) with both the allene and the alkene, followed by cyclization to intermediate **III**, through complex **II**. Insertion of CO in the C-Pd bond affords acyl-palladium compound **IV**, which is alkynylated to give intermediate **V** and then the final ynone **211** after a reductive elimination process.

Scheme 89. Oxidative Carbocyclization-Carbonylation-Alkynylation of Enallenes **210 Catalyzed by Pd(TFA)₂**

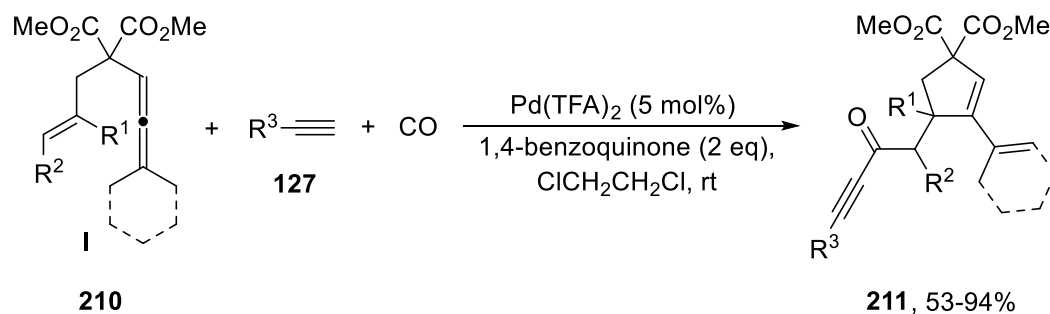

$R^1 = R^2 = \text{H, Me}$

$R^3 = \text{Ph, 2-MeOC}_6\text{H}_4, 3\text{-MeOC}_6\text{H}_4, 4\text{-MeC}_6\text{H}_4, 4\text{-FC}_6\text{H}_4, 4\text{-F}_3\text{CC}_6\text{H}_4, 2\text{-thienyl, 3-thienyl, } n\text{C}_6\text{H}_{13}, c\text{C}_5\text{H}_9, \text{styryl, Ph(CH}_2)_2, \text{Cl(CH}_2)_3, \text{TMS}$

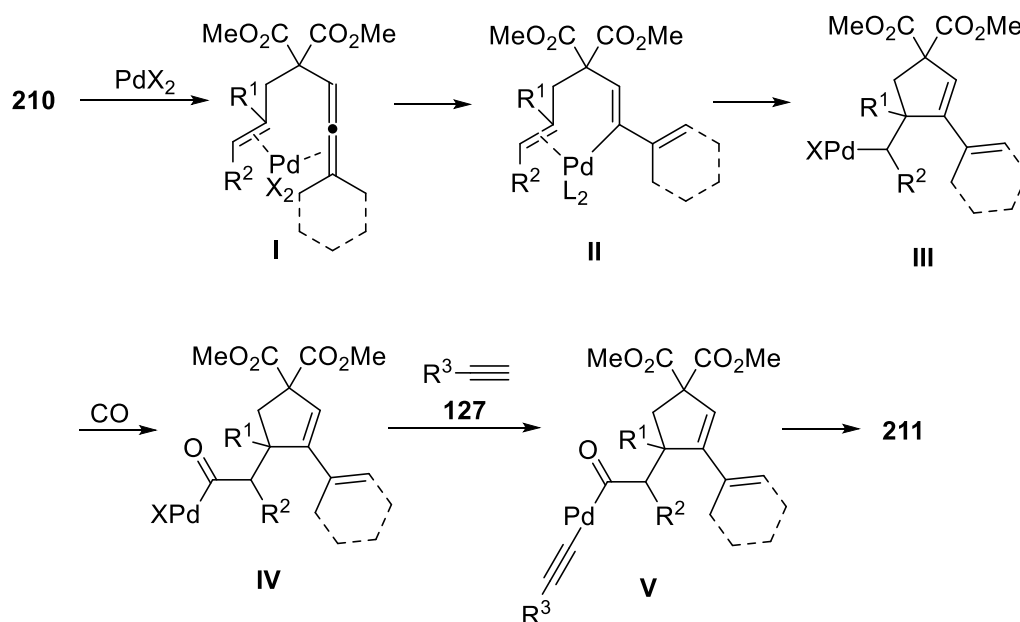

Working with different enallenes **212** under similar reaction conditions the same group prepared ynone-cyclopentenones **213** in variable yields (Scheme 90).²⁷⁹ In this case, the proposed mechanism involves formation of intermediates **I-V** of the same type as those shown in Scheme 89 and also the same type of processes: coordination to both double bonds (\rightarrow **I**), formation of a α -Pd complex **II**, insertion of CO (\rightarrow **III**), cyclization (\rightarrow **IV**), carbonylation (\rightarrow **V**), and final alkylation-reductive elimination to yield the ynone **213**.

Scheme 90. Oxidative Carbonylation-Carbocyclization-Carbonylation-Alkylation of Enallenes 212 Catalyzed by Pd(TFA)₂

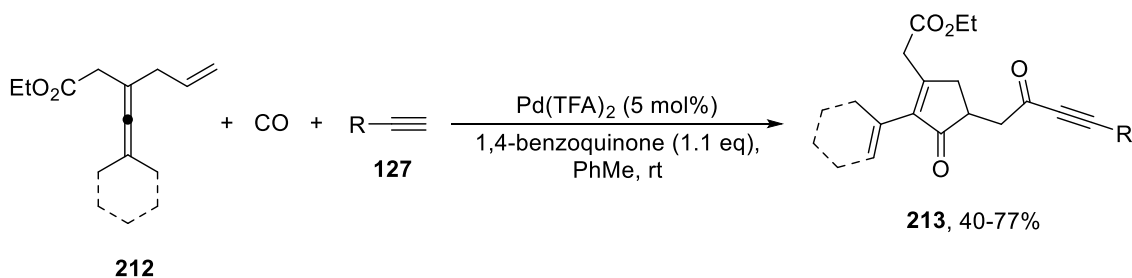

R = Ph, 2-MeOC₆H₄, 3-MeOC₆H₄, 4-MeC₆H₄, 4-FC₆H₄, 4-F₃CC₆H₄, 2-thienyl, 3-thienyl, nC₆H₁₃, cC₅H₉, styryl, Ph(CH₂)₂, Cl(CH₂)₃, TMS

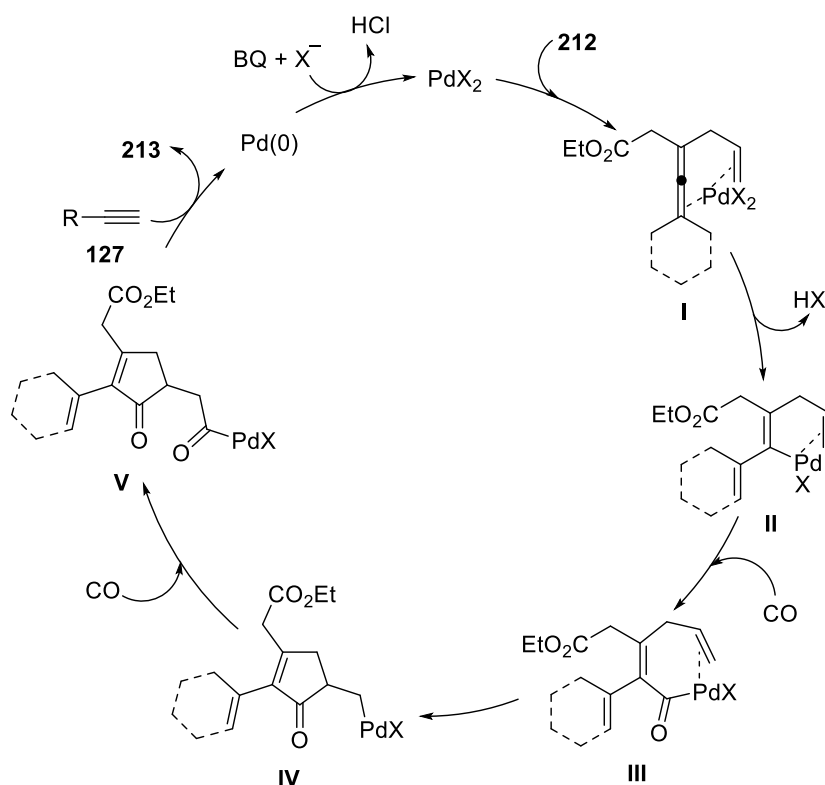

Xiao and co-workers have reported a decarboxylative carbonylative procedure as a new strategy for the synthesis of ynones.²⁸⁰ Working under photocatalytic conditions, carboxylic acids can be decarboxylated and furnish radicals that can be alkynylated with ethynylbenziodoxolanes (EBX, **214**) giving alkynones. The reaction was performed with 2 mol% of Ir[dF(CF₃)PPy]₂(dtbbPy)PF₆ [dF(CF₃)PPy = 2-(2,4-difluorophenyl)-5-(trifluoromethyl)pyridine; dtbbPy = 4,4'-di-*tert*-butyl-2,2'-bipyridine) as photocatalyst, Cs₂CO₃ as base, and 60 bar of CO in dichloromethane at room temperature applying 2 × 8 W blue LEDs (Scheme 91). A plausible mechanism is depicted in Scheme 91 showing that after an initial single-electron oxidation of the carboxylic acid by the excited state of the Ir(III) photocatalyst, the aliphatic radical is formed. After carbonylation, the resulting acyl radical adds to R-EBX and gives radical intermediate **I**, which after β-elimination affords the ynone and the iodanyl radical that oxidizes the Ir(II) species to Ir(III).

Scheme 91. Photocatalyzed Decarboxylative Carbonylative Alkynylation of Aliphatic Carboxylic Acids with Hypervalent Iodine Reagents 214

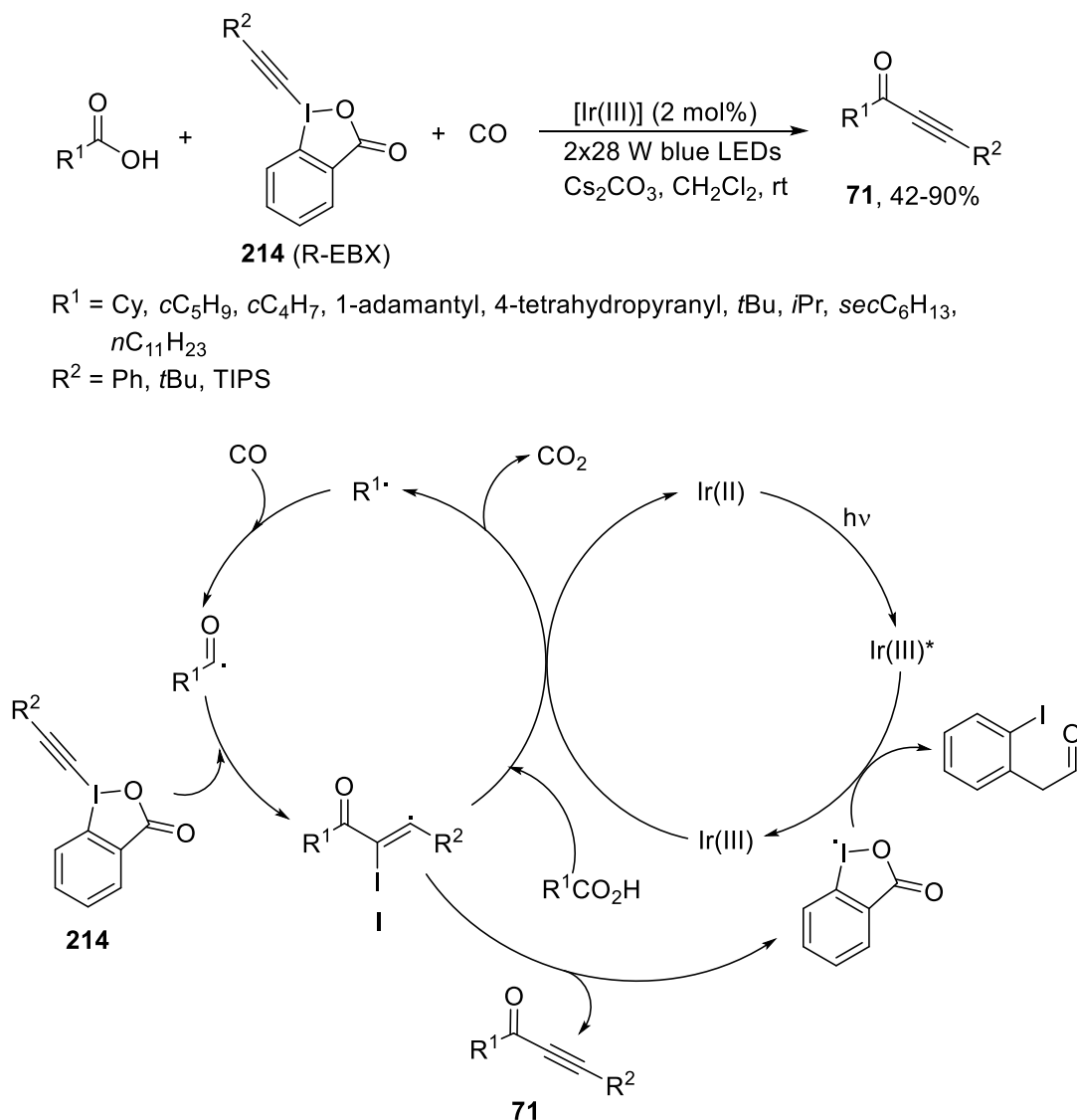

In conclusion, intramolecular domino carbonylation-alkynylation of enallenes under Pd catalysis in the presence of 1-4-benzoquinone as oxidant is an efficient methodology for the synthesis of cyclopentenyl ynones derivatives. Also, recently, a cascade process based on a decarboxylative carbonylative alkynylation of carboxylic acid with hypervalent iodine reagents is a new strategy for ynones.

2.4. From Other Substrates

2.4.1. From Aldehydes. The group of Lei has recently described the first coupling of aldehydes with terminal alkynes **127** through a ZnI_2 -promoted nucleophilic addition followed by an Oppenauer oxidation to yield ynones **71**.^{281,282} Initial studies were carried out with 2.5 eq of benzaldehyde and phenylacetylene in the presence of 2.5 eq of ZnI_2 and Et_3N in toluene at 80 °C affording 1,3-diphenylpropynone in 85% yield. This dehydrogenative cross-coupling was further performed by the same group under Zn-

catalyzed conditions using a ketone as oxidant.²⁸³ The reaction took place with 15 mol% of $\text{Zn}(\text{OTf})_2$ and 5 mol% of $\text{In}(\text{OTf})_3$ as co-catalyst in the presence of 1.2 eq of α,α,α -trifluoroacetophenone as oxidant, Et_3N (2.4 eq) as base in toluene at 80 °C. In this case, both components were used in a 1:1 molar ratio using aromatic aldehydes as well as pivalaldehyde and aromatic and aliphatic terminal alkynes giving ynones **71** in good yields (Scheme 92). The proposed mechanism, based on experimental results, starts with $\text{Zn}(\text{II})$ coordination to the carbonyl group (**I**) and base-promoted formation of the corresponding alkynylzinc species **II**. After nucleophilic addition of **II** to **I**, the propargylic zinc alkoxide can be formed, which will coordinate with the ketone and undergo hydrogen transfer through a six-membered transition state (**III**), which evolves giving the expected ynone **71** and the zinc alkoxide derived from PhCOCF_3 . $\text{In}(\text{OTf})_3$ probably plays a role in the activation of the terminal alkyne **127** and the aldehyde.

Scheme 92. Dehydrogenative Cross-Coupling of Aldehydes with Terminal Alkynes 127 Catalyzed by $\text{Zn}(\text{OTf})_2$

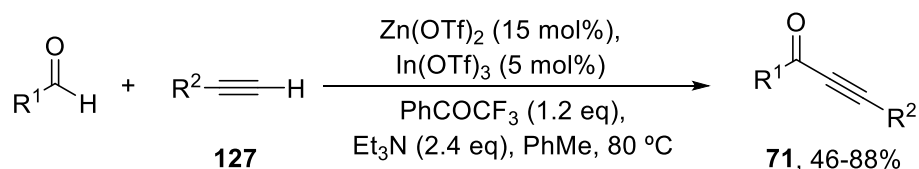

$\text{R}^1 = \text{Ph, 4-MeC}_6\text{H}_4, 3\text{-MeC}_6\text{H}_4, 2\text{-MeC}_6\text{H}_4, 2\text{-ClC}_6\text{H}_4, 4\text{-ClC}_6\text{H}_4, 4\text{-BrC}_6\text{H}_4,$
 $4\text{-IC}_6\text{H}_4, 4\text{-MeOC}_6\text{H}_4, 2\text{-MeOC}_6\text{H}_4, 4\text{-F}_3\text{CC}_6\text{H}_4, 2\text{-naphthyl, 2-thienyl, } t\text{Bu}$
 $\text{R}^2 = \text{Ph, 4-MeC}_6\text{H}_4, 3\text{-MeC}_6\text{H}_4, 2\text{-MeC}_6\text{H}_4, 4\text{-FC}_6\text{H}_4, 2\text{-ClC}_6\text{H}_4, 4\text{-ClC}_6\text{H}_4,$
 $3\text{-BrC}_6\text{H}_4, 4\text{-BrC}_6\text{H}_4, 4\text{-F}_3\text{CC}_6\text{H}_4, 4\text{-MeO}_2\text{CC}_6\text{H}_4, 4\text{-MeOC}_6\text{H}_4, 1\text{-naphthyl,}$
 $2\text{-thienyl, } t\text{Bu, } c\text{C}_3\text{H}_5, \text{TMS}$

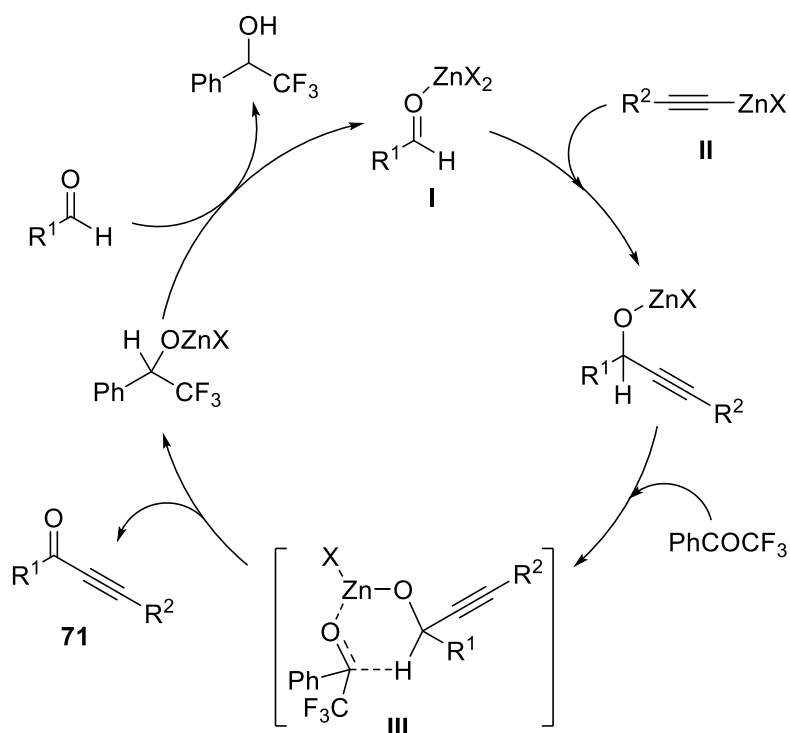

Sakai and co-workers described that InBr_3 (1.5 eq) and Et_3N (1.5 eq) promoted a similar dehydrogenative cross-coupling of aldehydes and terminal alkynes **127** leading to ynones **71** in 35-83% yield.²⁸⁴ This process is similar to the $\text{ZnI}_2/\text{Et}_3\text{N}$ -promoted reaction^{281,282} using an excess of aldehyde (3 eq) in ether at 40 °C.

Huang and co-workers²⁸⁵ described the coupling of aldehydes with hypervalent alkynyl iodides (**214**) giving ynones **16** under oxygen. The reaction was carried out with 1 eq of pyrrolidine, 1.2 eq of 1-[(triisopropylsilyl)ethynyl]-1,2-benziodoxol-3(1*H*)-one (TIPS-EBX, **214**), 10 mol% of AuCl_3 and 20 mol% of ligand **215** in ether at 40 °C (Scheme 93). Aliphatic aldehydes even bearing functional groups such as ethers, esters, carbamates, imides, olefins, alcohols, sulfonamides and heterocycles were excellent substrates giving ynones **16** in 60-70% yields. The proposed mechanism based on experimental data involves the formation of an allenyl aldehyde (**I**),²⁸⁶ which reacts with pyrrolidine to generate ynenamine intermediate **II**. Subsequent aerobic oxidation then affords 1,2-dioxetane **III**, which gives rise to ynone **16** and *N*-formylpyrrolidine.

Scheme 93. Aerobic Alkynylation of Aldehydes with TIPS-EBX (**214**) under AuCl_3 Catalysis via Oxidative C–C Bond Cleavage

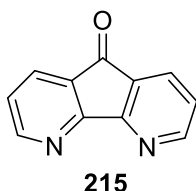
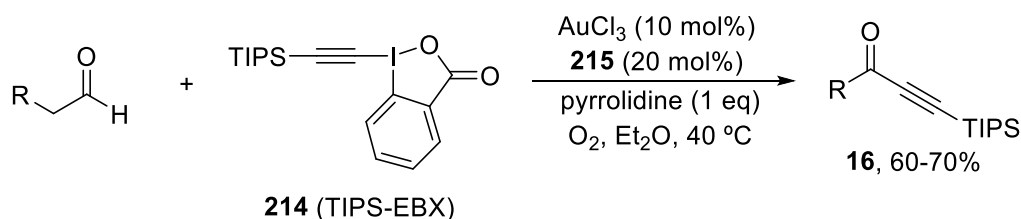

R = Ph, 4- BrC_6H_4 , 4- $\text{O}_2\text{NC}_6\text{H}_4$, 4- MeOC_6H_4 , 3- $\text{F}_3\text{CC}_6\text{H}_4$, 3-thienyl, $n\text{C}_5\text{H}_{11}$, $\text{BnO}(\text{CH}_2)_3$, $\text{TBSO}(\text{CH}_2)_3$, $\text{HO}(\text{CH}_2)_3$, $\text{CbzNH}(\text{CH}_2)_3$, $\text{MeOCO}(\text{CH}_2)_2$, $\text{Me}_2\text{C}=\text{CHCH}_2\text{NTsCH}_2$, (*Z*)- $\text{EtCH}=\text{CH}(\text{CH}_2)_2$

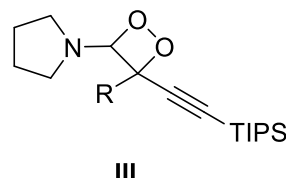
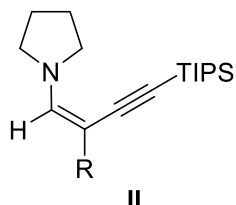
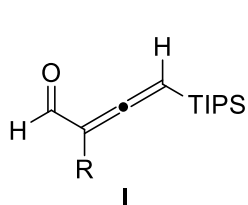

Rh(III)- or Ir(III)-catalyzed formal C–H activation of aromatic aldehydes with hydroxy or amino substituents at the *ortho* position has been achieved affording acylmetal intermediates, which were coupled with hypervalent iodine alkynyating reagents R-EBX.²⁸⁷ Salicylaldehydes **216** were alkynylated with TIPS-EBX (**214**) using 4 mol% of $[\text{IrCp}^*\text{Cl}_2]_2$ and CsOAc in methanol or dioxane at room temperature giving ynones **217** in good yields (Scheme 94). In the case of *N*-sulfonyl-2-aminobenzaldehydes **218**, 4

mol% of $[\text{RhCp}^*\text{Cl}_2]_2$ was used as catalyst under dichloromethane reflux and different EBX affording ynones **219** in good yields (Scheme 94). The proposed catalytic cycle for the Rh(III)-catalyzed C–H activation of tosylated *o*-aminobenzaldehyde **218** starts with the formation of rhodacyclic intermediate **I** which is alkynylated by R^2 -EBX (**214**) giving the Rh(V) intermediate **II**. Subsequent reductive elimination affords Rh(III) intermediate **III**, which undergoes substitution of benzoate by acetate giving intermediate **IV**. Final protonolysis gives ynone **219** and regenerates the catalyst.

Scheme 94. Alkynylation of Aldehydes **216 and **218** with Hypervalent Iodine Alkynylating Reagents EBX (**214**) Catalyzed by Ir(III) and (Rh(III) Complexes**

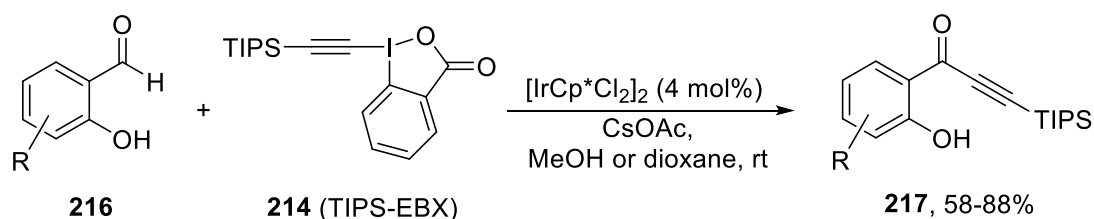

R = H, 6-Me, 6-MeO, 6-Br, 5-Me, 5-MeO, 4,6-Cl₂, 4,6-Br₂, 4-Cl-6-Br, 4-Cl, 5-Br, 4-Cl, 4-MeO, 4-F, 4-O₂N

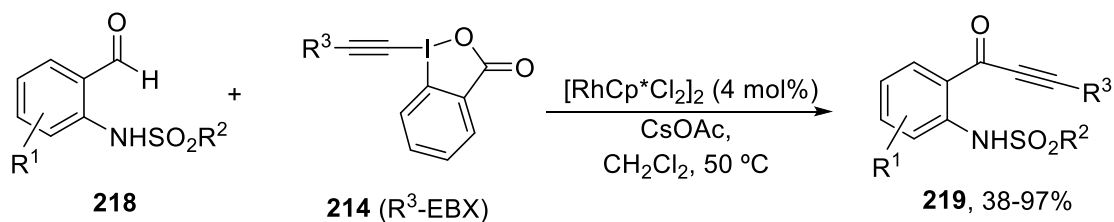

R¹ = H, 4-Me, 4-F, 4-Cl, 4-Br, 5-O₂N

R² = Ph, 4-MeC₆H₄, 4-*t*BuC₆H₄, 4-PhC₆H₄, 4-ClC₆H₄, 4-O₂NC₆H₄, 3-F₃CC₆H₄, 1-naphthyl, Me

R³ = TIPS, TDBPS, TES, *t*Bu

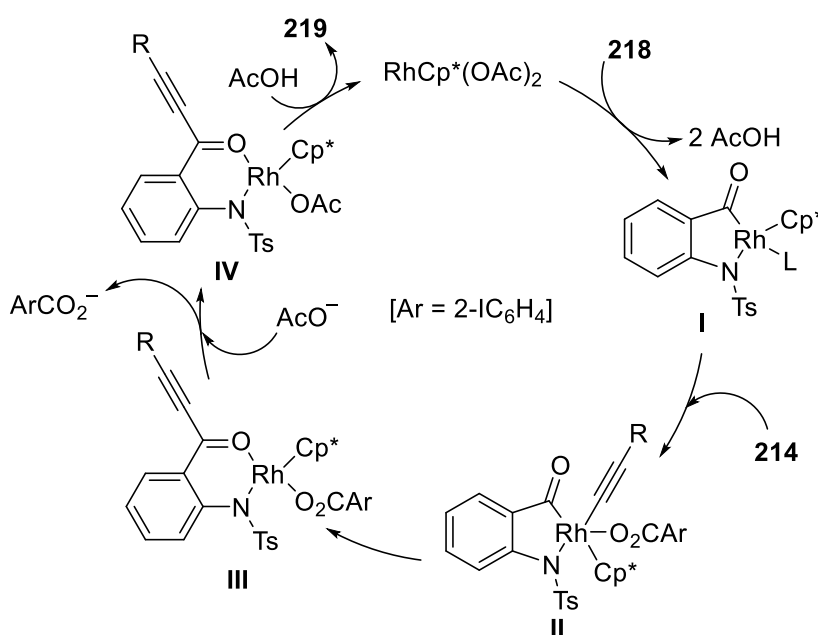

Simultaneously, Yang, Zhou and co-workers described a similar ynone synthesis using 8-quinolinecarbaldehydes (**220**) and TIPS-EBX (**214**) under Rh(III) catalysis (Scheme 95).²⁸⁸ In this case, silylated alkynones **221** were obtained in good yields using 2.5 mol% of $[\text{RhCp}^*\text{Cl}_2]_2$ and 10 mol% of $\text{Zn}(\text{OTf})_2$ in refluxing dichloromethane. When *N*-sulfonyl-2-aminobenzaldehydes **218** and salicylaldehydes **216** reacted with R^2 -EBX (**214**) using 2.5 mol% of $[\text{IrCp}^*\text{Cl}_2]_2$ and 10 mol% of AgNTf_2 with NaOAc (0.5 eq) as base in a mixture of dichloroethane and AcOH at 80 °C, the corresponding ynones, **219** and **217** respectively, were obtained in good yields (Scheme 95).

Scheme 95. Alkynylation of Aldehydes **220, **216** and **218** with R^2 -EBX (**214**) under Rh or Ir Catalysis**

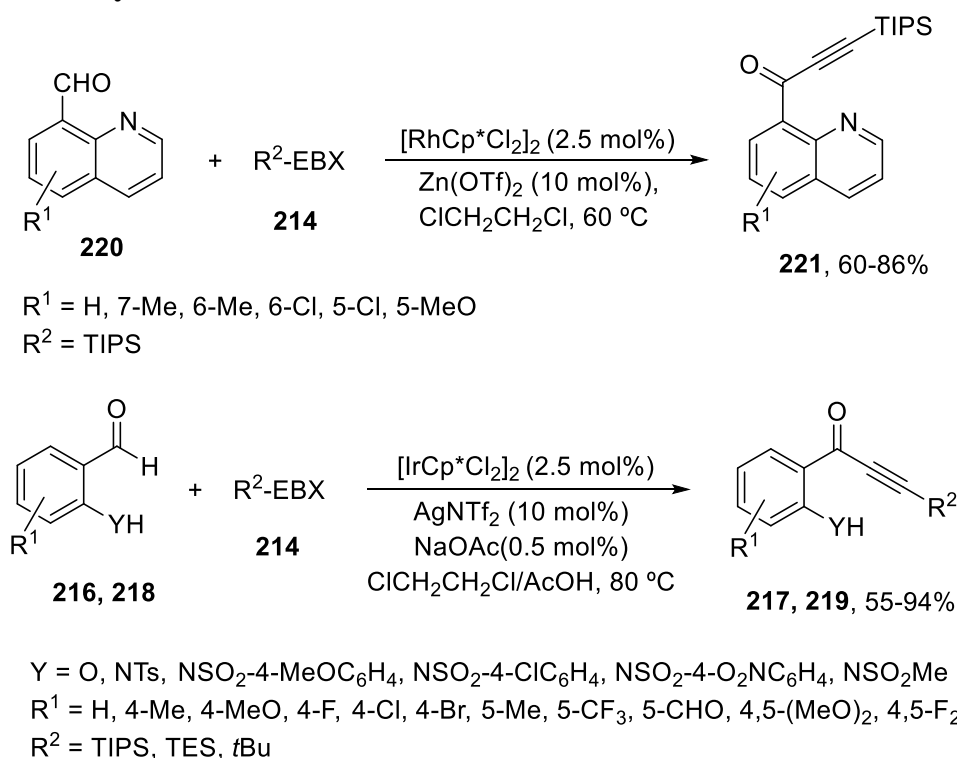

Wei and coworkers²⁸⁹ published the first metal-free C–H alkynylation of aldehydes with TIPS-EBX (**214**) under radical conditions. In this case, the presence of a directing group at the *ortho* position is not necessary because *tert*-butyl hydroperoxide (TBHP) generates the corresponding acyl radical, which is trapped by benziodoxolane hypervalent iodine reagent **214**. This general process took place in toluene at 130 °C with 1.2 eq of TIPS-EBX (**214**) and 1.5 eq of TBHP with aliphatic and aromatic aldehydes leading to ynone **16** in low to high yields (Scheme 96).

Scheme 96. Radical Alkynylation of Aldehydes with TIPS-EBX (214**)**

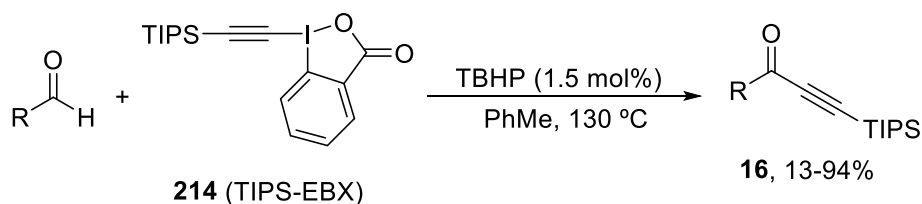

R = Ph, 2-MeC₆H₄, 2-HOC₆H₄, 2-BocNHC₆H₄, 3,4,5-(MeO)₃C₆H₂, 2-naphthyl, 2-furyl, 4-indolyl, 3-thienyl, 2-(1-methyl)pyrrolyl, 2-thienyl, (1-methyl)-3-indolyl, (1-methyl)-5-indolyl, benzo-2-furyl, benzo-2-thienyl, benzo-3-thienyl, 3,5-dimethyl-4-oxazolyl

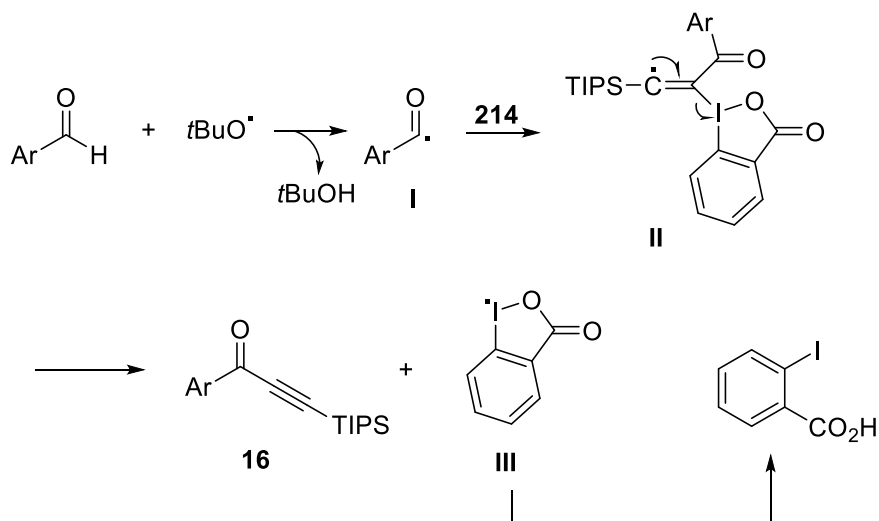

Independently, Yu and co-workers²⁹⁰ reported the same radical process using 1,2-dichloroethane as solvent at 100 °C giving TIPS-ynones **16** (R = aryl, hetaryl) in 35-80% yield. They also used other R-EBX (R = *t*Bu, aryl, **214**) leading to ynones **71** in 58-80% yields. The proposed reaction mechanism involves the formation of benzoyl radical **I** in the presence of TBHP, which adds to the triple bond of TIPS-EBX (**214**) forming a new radical (**II**) (Scheme 96). The subsequent β -elimination gives ynone **16** and iodanyl radical **III** which is further transformed into *o*-iodobenzoic acid. A similar mechanism has been shown in Section 2.3.3. The same radical reaction was also reported by Li and co-workers²⁹¹ using aliphatic, aromatic and heteroaromatic aldehydes and TIPS- as well as alkyl-, aryl- and heteroaryl-EBX (**214**) for the general synthesis of ynones which were obtained in moderate yields (45-75%). In this case, chlorobenzene was used as solvent and the reaction was performed at 120 °C. They also proposed an alternative mechanistic pathway illustrated in Scheme 97. R-EBX reagent **214** can react with TBHP and afford iodine hypervalent intermediate **I**, which expels *o*-iodobenzoic acid radical **II** and generates radical **III**. This *tert*-butylperoxy radical will react with the aldehyde giving a new radical (**IV**) which after β -elimination provides ynone **16/71**.

Scheme 97. Alternative Mechanism for the Radical Alkynylation of Aldehydes with R-EBX 214

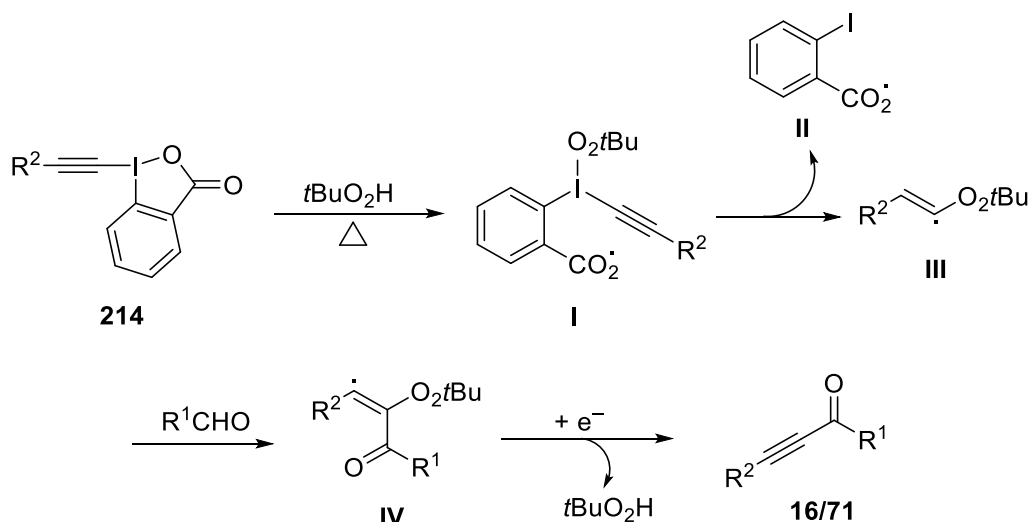

In conclusion, the dehydrogenative cross-coupling of aldehydes with terminal alkynes catalyzed or promoted by Zn(II)- or In(III)-derived Lewis acids is the most simple procedure for the preparation of ynones. Recent efficient methodologies using hypervalent iodine(III) compounds R-EBX as alkynylating reagents of aldehydes under transition-metal catalysis or under radical conditions can be alternatively used.

2.4.2. From Propiolic Acid Derivatives. Propiolic esters **222** can react with organolithium reagents giving after nucleophilic substitution the corresponding ynones **223**. Thus, the reaction of acetylenic esters **222** with *in situ*-generated α -lithiated (*R*)-methyl *p*-tolyl sulfoxide afforded ynones **223** (Scheme 98).²⁹² The corresponding ynones were applied to the synthesis of α -acetylenic epoxides **98**.

Scheme 98. Reaction of Acetylenic Esters 222 with Lithiated Methyl *p*-Tolyl Sulfoxides

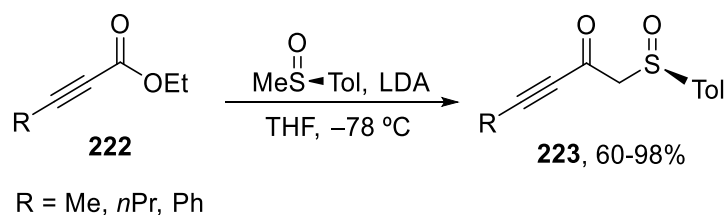

Ethyl acetylenic esters reacted with dibromomethyl lithium, generated *in situ* from dibromomethane and LDA at $-78\text{ }^\circ\text{C}$, giving ynones **224** in good yields (Scheme 99).²⁹³ These ynones were further transformed into highly functionalized vinyl triflates.

Scheme 99. Reaction of Acetylenic Esters 222 with *in situ*-Generated Dibromomethyl lithium

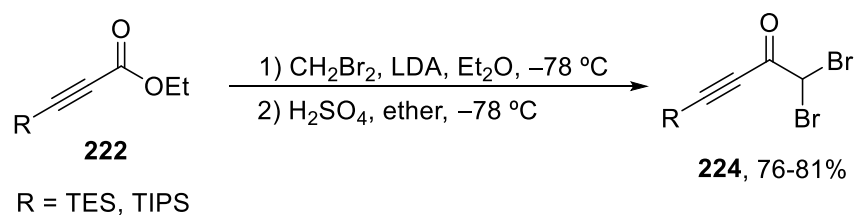

Taylor and co-workers have prepared ynones that have been used as starting materials to synthesize the quinolizidine motif,²⁹⁴ a framework present in a number of bioactive natural products.²⁹⁵ For instance, pyridine ynone **225** was obtained by reaction of methyl phenylpropiolate with lithiated 2-picoline (Scheme 100), and this ynone was used to synthesize (\pm)-lasubine II (Scheme 150).

Scheme 100. Reaction of Methyl Phenylpropiolate with Lithiated 2-Picoline

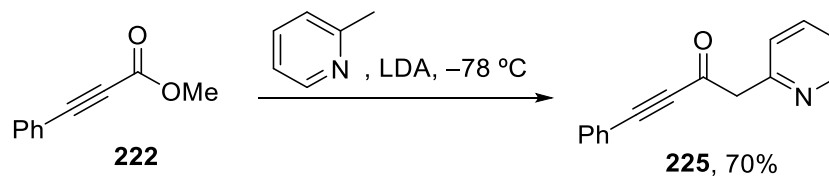

A second strategy for the synthesis of ynones starting from alkyne acids is the Friedel–Crafts acylation of aromatic compounds. Ferrocene reacted with acetylenic acids **226** using 1 eq of trifluoroacetic anhydride (TFAA) and 1 eq of triflic acid or 4 eq of $\text{BF}_3 \cdot \text{OEt}_2$ at room temperature, affording ynones **195** in good yields (Scheme 101).²⁹⁶

Scheme 101. Friedel–Crafts Acylation of Ferrocene with Alkyne Acids 226

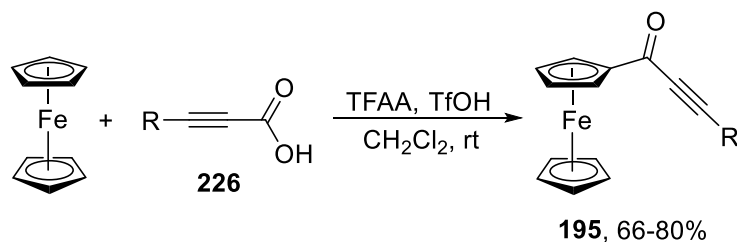

R = Me, *n*Pr, *n*C₅H₁₁, Ph, TMS

1-Pyrenyl ynones **227**, a new class of pyrenyl solid-state emitters, have been prepared by a Friedel–Crafts acylation of pyrene with 2-alkynoic acids **226** (Scheme 102).²⁹⁷

Scheme 102. Friedel–Crafts Acylation of Pyrene with Alkyne Acids 226

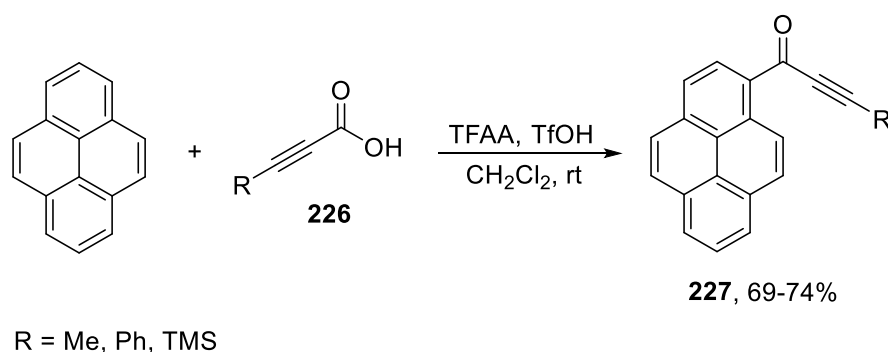

In conclusion, propiolic esters can be chemoselectively transformed into ynones by addition of organolithium compounds to the ester group at low temperatures. In addition, alkynoic acids can be used as acylating agent of aromatic compounds under Friedel–Crafts reaction conditions.

2.4.3. From α -Keto Acids. Parallel to the studies of the alkylation of aldehydes with hypervalent iodine reagents R-EBX (**214**) under radical conditions,²⁸⁹⁻²⁹¹ several Chinese groups have reported the decarboxylative ynylation of α -keto acids.²⁹⁸⁻³⁰¹ Simultaneous application of **214** and photoredox catalysis with visible light induced decarboxylative ynylation of α -keto acids **189** via acyl-radical intermediates.²⁹⁸ The α -keto acids were allowed to react with 1.5 eq of benziodoxole acetate (BI-OAc) and 1 eq of **214** in the presence of 2 mol% of [Ru(bpy)₃](PF₆)₂ as photocatalyst in dichloromethane under irradiation with blue light-emitting diodes (LEDs, $\lambda_{\text{max}} = 468 \pm 25$ nm) affording ynones **71** in moderate to good yields (Scheme 103). The mechanism proposed postulated the formation of a BI-keto acid intermediate (**I**) which is oxidized by [Ru(bpy)₃]²⁺ and gives acyl radical **II** after decarboxylation. As shown in Scheme 97, the acyl radical undergoes α -addition to AcO-EBX, giving radical **III** which after elimination of benziodoxole radical affords the ynone **71**. The benziodoxole radical oxidizes the photoexcited [Ru(bpy)₃]^{2+*} to complete the photoredox cycle.

Scheme 103. Decarboxylative Alkylation of α -Keto Acids **189 with R-EBX (**214**) and BIOAc by Photoredox Catalysis**

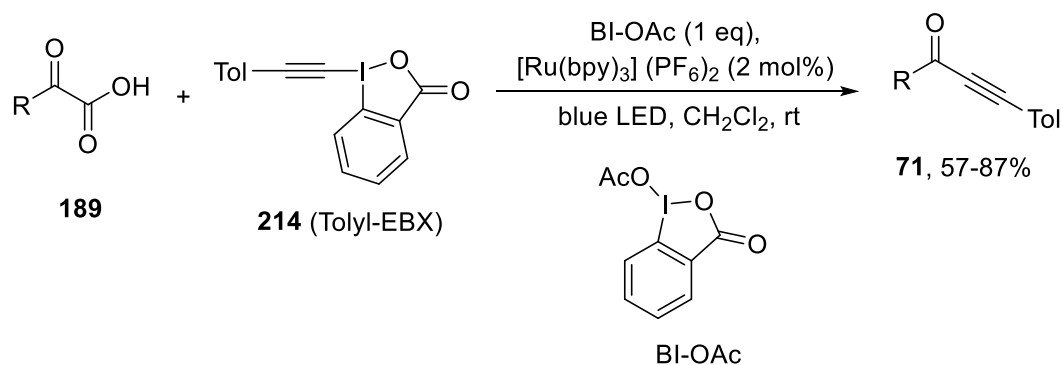

R = 4-MeC₆H₄, 4-MeOC₆H₄, 3-EtO₂CC₆H₄, 4-F₃CC₆H₄, 4-FC₆H₄, 4-BrC₆H₄, 4-IC₆H₄, 4-(HCCCH₂O)C₆H₄, 4-(CH₂=CHCH₂O)C₆H₄, 4-(HOCH₂CH₂)C₆H₄, 4-[N₃(CH₂)₄]C₆H₄, 2,5-Me₂C₆H₃, 2,3,5-Me₃C₆H₂, 2-furyl, 2-thienyl, 3-(1-methyl)indolyl, Ph(CH₂)₂, Cy, *t*Bu

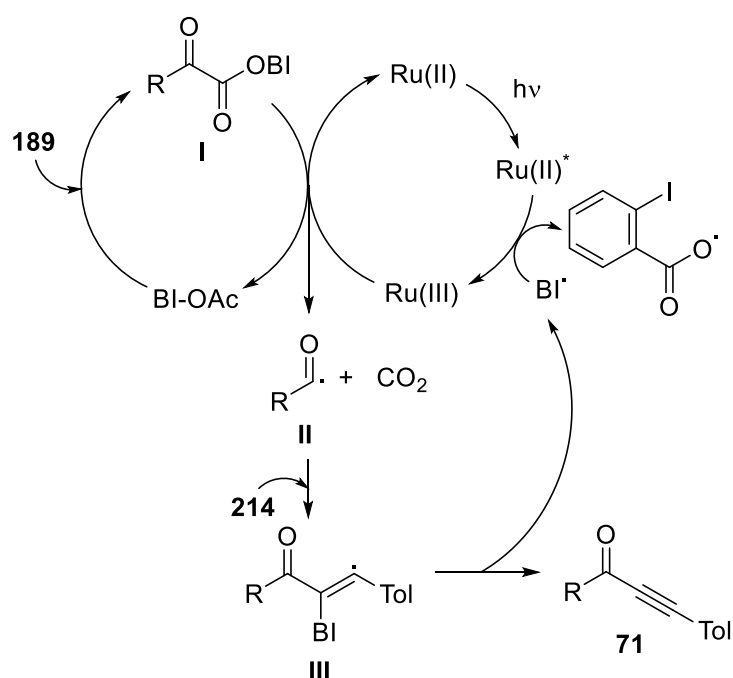

The decarboxylative alkylation reaction of α -keto acids **189** with bromoacetylenes **228** took place under sunlight using hypervalent iodine reagent BIOH as catalyst, affording ynones in moderate to good yields (Scheme 105).²⁹⁹ According to experimental data, firstly BI-OH reacted with the α -keto acid giving intermediate **I** (like in Scheme 103) which evolved to iodanyl radical **II** and acyl radical **III** after decarboxylation. Addition of **III** to R²-EBX (**214**) leads to formation of radical **IV**, which releases the ynone **71** and radical **II**. In addition, R²-EBX (**214**) was generated by reaction of **II** with bromoacetylene and also reacted with Br⁻ to give BI-Br, which was hydrolyzed to BI-OH (Scheme 104).

Scheme 104. Decarboxylative Alkylation of α -Keto Acids 189 with Bromoacetylenes 228 Catalyzed by BI-OH and Sunlight

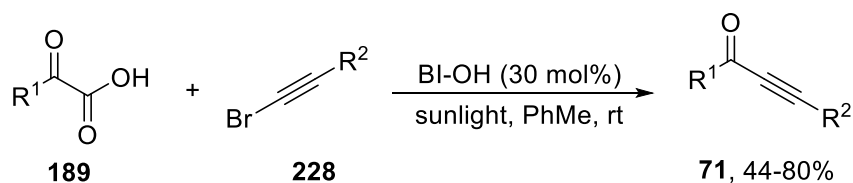

$\text{R}^1 = \text{Ph, 2-FC}_6\text{H}_4, 4\text{-FC}_6\text{H}_4, 2\text{-ClC}_6\text{H}_4, 4\text{-ClC}_6\text{H}_4, 2\text{-BrC}_6\text{H}_4, 4\text{-BrC}_6\text{H}_4,$
 $2\text{-MeC}_6\text{H}_4, 4\text{-MeC}_6\text{H}_4, 2\text{-MeOC}_6\text{H}_4, 4\text{-MeOC}_6\text{H}_4, 2,5\text{-Me}_2\text{C}_6\text{H}_3,$
 $2,4\text{-Me}_2\text{C}_6\text{H}_3, 3,4\text{-(MeO)}_2\text{C}_6\text{H}_3, 3,4\text{-(OCH}_2\text{O)}_2\text{C}_6\text{H}_3, i\text{Bu}$
 $\text{R}^2 = \text{Ph, 4-FC}_6\text{H}_4, 4\text{-ClC}_6\text{H}_4, 4\text{-BrC}_6\text{H}_4, 4\text{-AcOC}_6\text{H}_4, 4\text{-MeC}_6\text{H}_4, 4\text{-}n\text{PrC}_6\text{H}_4,$
 $4\text{-}n\text{BuC}_6\text{H}_4, 4\text{-MeOC}_6\text{H}_4, 2\text{-MeC}_6\text{H}_4, 2\text{-BrC}_6\text{H}_4, 3\text{-FC}_6\text{H}_4, 3\text{-MeC}_6\text{H}_4,$
 $n\text{C}_5\text{H}_{11}$

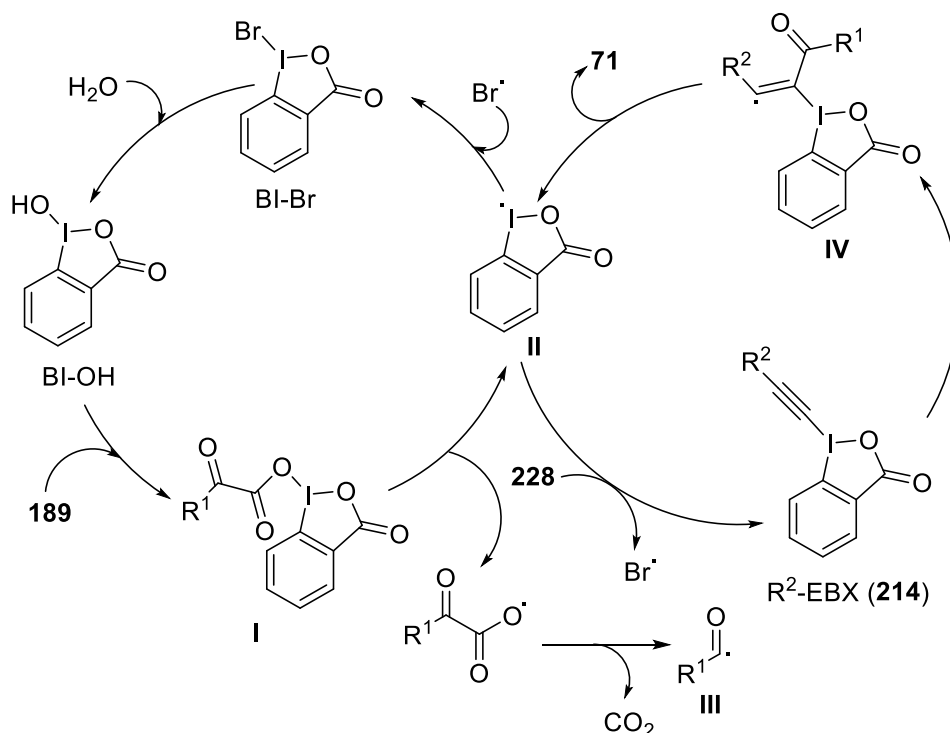

Duan and co-workers reported also a decarboxylative alkynylation of α -keto acids using R-EBX and potassium persulfate as promoter.³⁰⁰ Aryl and alkyl α -keto acids **189** reacted with alkyl, aryl and silylated EBX (**214**) in the presence of 0.7 eq of $\text{K}_2\text{S}_2\text{O}_8$ in a 1:1 mixture of $\text{MeCN}:\text{H}_2\text{O}$ at 50°C leading to ynones **71** in variable yields (Scheme 105). In this case, it was proposed that the generation of the acyl radical is by oxidative decarboxylation of **189** induced by $\text{K}_2\text{S}_2\text{O}_8$. The addition of this radical to $\text{R}^2\text{-EBX}$ (**214**) has been described in Scheme 96. For oxamic acids, the corresponding propiolamides were obtained.

Scheme 105. Decarboxylative Alkynylation of α -Keto Acids **189 with $\text{R}^2\text{-EBX}$ (**214**) Promoted by $\text{K}_2\text{S}_2\text{O}_8$**

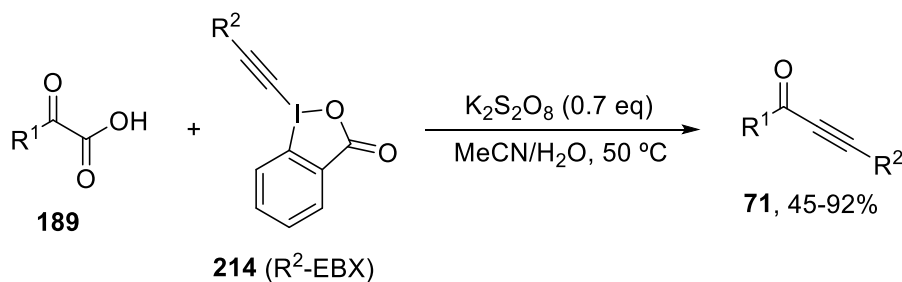

R¹ = Me, Ph, 4-MeC₆H₄, 4-MeOC₆H₄, 4-FC₆H₄, 4-ClC₆H₄, 4-IC₆H₄, 4-F₃CC₆H₄,
 2-MeC₆H₄, 2-FC₆H₄, 2-ClC₆H₄, 2-F₃CC₆H₄, 3-MeOC₆H₄, 3-ClC₆H₄,
 3-BrC₆H₄, 2,4-Me₂C₆H₃, 2,4-Cl₂C₆H₄, 1-naphthyl, 2-naphthyl, 2-thienyl
 R² = TIPS, TBS, Ph, 4-FC₆H₄, *n*Bu

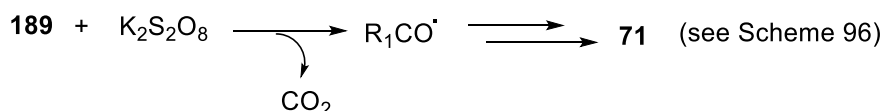

Independently, Feng, Xu and co-workers described the same procedure for the decarboxylative alkynylation of α -keto acids **189** with R-EBX (**214**) and K₂S₂O₈ leading to ynones **71** in 31-92% yields.³⁰¹

In conclusion, the decarboxylative alkynylation of α -keto acids is a new strategy for the synthesis of ynones, the use of bromoacetylenes catalyzed by hydroxy benziodoxole and sunlight at room temperature being the simplest procedure of all the processes induced by hypervalent iodine(III) reagents.

2.4.4. From Propargylic Esters. A new strategy for the synthesis of ynones has been reported by Hashmi and co-workers³⁰² using a gold-catalyzed dehydrogenative Meyer–Schuster-like rearrangement.³⁰³ Propargyl pivalates (**229**) were transformed into ynones **71** in moderate to good yields under Ph₃PAuCl (2 mol%) and AgNTf₂ (2 mol%) catalysis and using PhI(OAc)₂ as oxidant (Scheme 106). The authors proposed that the propargyl pivalate under Ph₃PAu⁺ catalysis undergoes an isomerization to allene **230** which suffers a 1,3-acyloxy shift giving intermediate **I**, that after hydrolysis gives intermediate **II**. This intermediate is oxidized by PhI(OAc)₂ giving Au(III) species **III**, acetate and iodobenzene. This acetate promotes the β -elimination on **III** leading to ynone **71** and the gold(I) catalyst (Scheme 106).

Scheme 106. Dehydrogenative Meyer–Schuster-Like Rearrangement of Propargylic Esters 229 Catalyzed by Au(I)

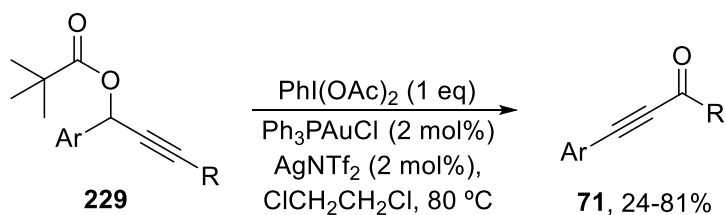

Ar = Ph, 4-MeC₆H₄, 4-FC₆H₄, 2-FC₆H₄, 4-ClC₆H₄, 4-O₂NC₆H₄,
3-BrC₆H₄, 2-MeC₆H₄
R = *n*Bu, *i*Bu, *c*C₅H₉, *t*Bu, *c*C₃H₅, Cy

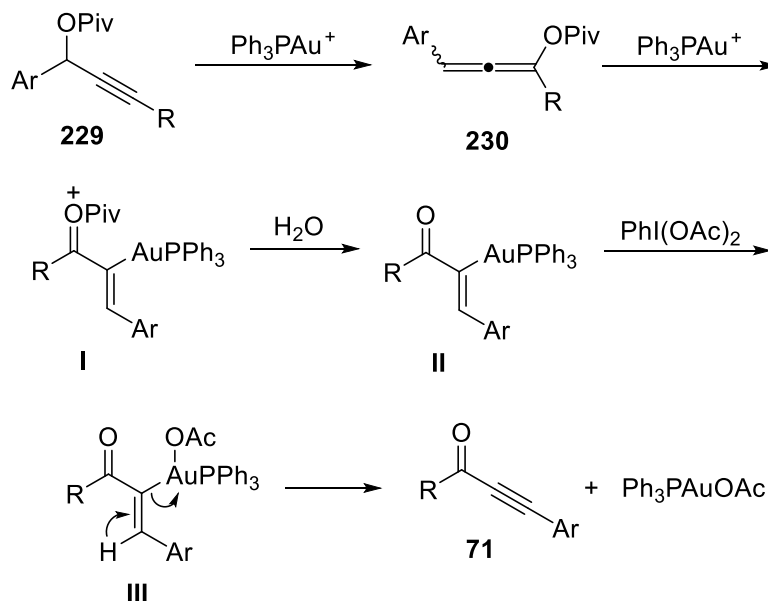

2.4.5. From Aryl Iodides. An anthraquinone-ynone (**233**) has been synthesized by cross-coupling of copper acetylide **232** with aryl iodide **231** derived from anthraquinone (Scheme 107).⁵⁴ This synthetic route can be considered a Castro–Stevens reaction giving the ynone in excellent yield. Unfortunately, the resulting pyranone obtained by cyclization with H_2SO_4 did not show growth inhibition against several cancer cell lines.

Scheme 107. Castro–Stevens Reaction of Aryl Iodide 231 and the Ynone-Derived Copper Acetylide 232

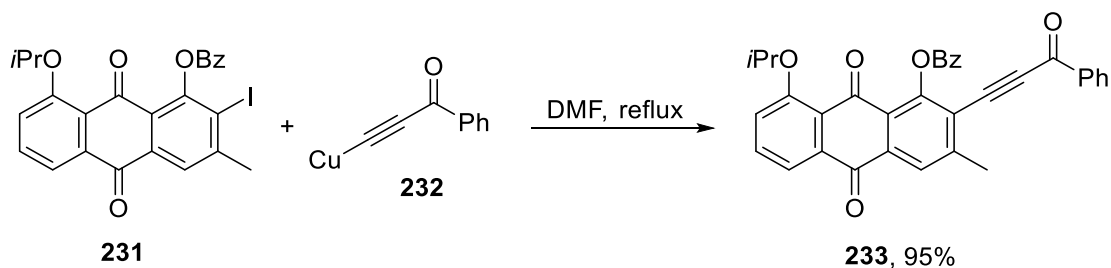

R = Me, Ph, TMS

3. TRANSFORMATIONS OF YNONES

In this Section, the chemical capabilities of the ynones are presented. The most important reactions are conjugate additions of boron, carbon and heteronucleophiles and radicals and [2+2], [3+2] and [4+2] cycloadditions, but additions to the carbonyl group of carbon and heteronucleophiles and some other reactions will also be considered. In general, as expected, soft nucleophiles give 1,4-addition, whereas hard nucleophiles undergo 1,2-addition.

3.1. Conjugate Additions

Attack of α,β -unsaturated acetylenic ketones in a Michael fashion, leading to formation of α,β -unsaturated alkenones as primary products, is among the most important reactions ynones undergo. The final outcome in a given case depends on several factors, first and foremost of the nucleophilicity and electrophilicity of the reactants, then additives like catalysts and complexing species that influence these properties, and the presence of one or several other reactive groups, appropriately positioned elsewhere in the substrate or in an additive, that can trap an intermediate and redirect the reaction.

The stage is generally set by the nucleophilic reagents, which in the following is used to divide the reactions into groups. The largest variety of such reagents is exhibited by carbon nucleophiles followed by nitrogen bisnucleophiles which have been used extensively to synthesize a range of heterocyclic compounds.

3.1.1. Boron Nucleophiles. Boration is an important group of reactions that have been applied extensively in organic synthesis. The transformation is achieved by classical hydroboration of electron-rich alkenes and alkynes and by metal-catalyzed boron conjugate addition of α,β -unsaturated olefinic carbonyl compounds such as aldehydes and ketones.^{304,305} However, conjugate addition to α,β -unsaturated acetylenic carbonyl compounds has barely been reported, but a recent publication by Santos and co-workers indicates that the reaction may have synthetic utility.³⁰⁴ Thus, when but-3-yn-2-one (**71**) was exposed to a mixture of pinacolato diisopropanolaminato diboron (PDIPA, **234**) and copper(I) chloride, double conjugate addition took place and gave 4,4-bis(4,4,5,5-tetramethyl-1,3,2-dioxaborolan-2-yl)butan-2-one (**235**) in 79% yield (Scheme 108). A possible reaction mechanism is depicted in the same Scheme involving intermediates **I-III**.

Scheme 108. Copper-Catalyzed β -Boration of But-3-yn-2-one (71)

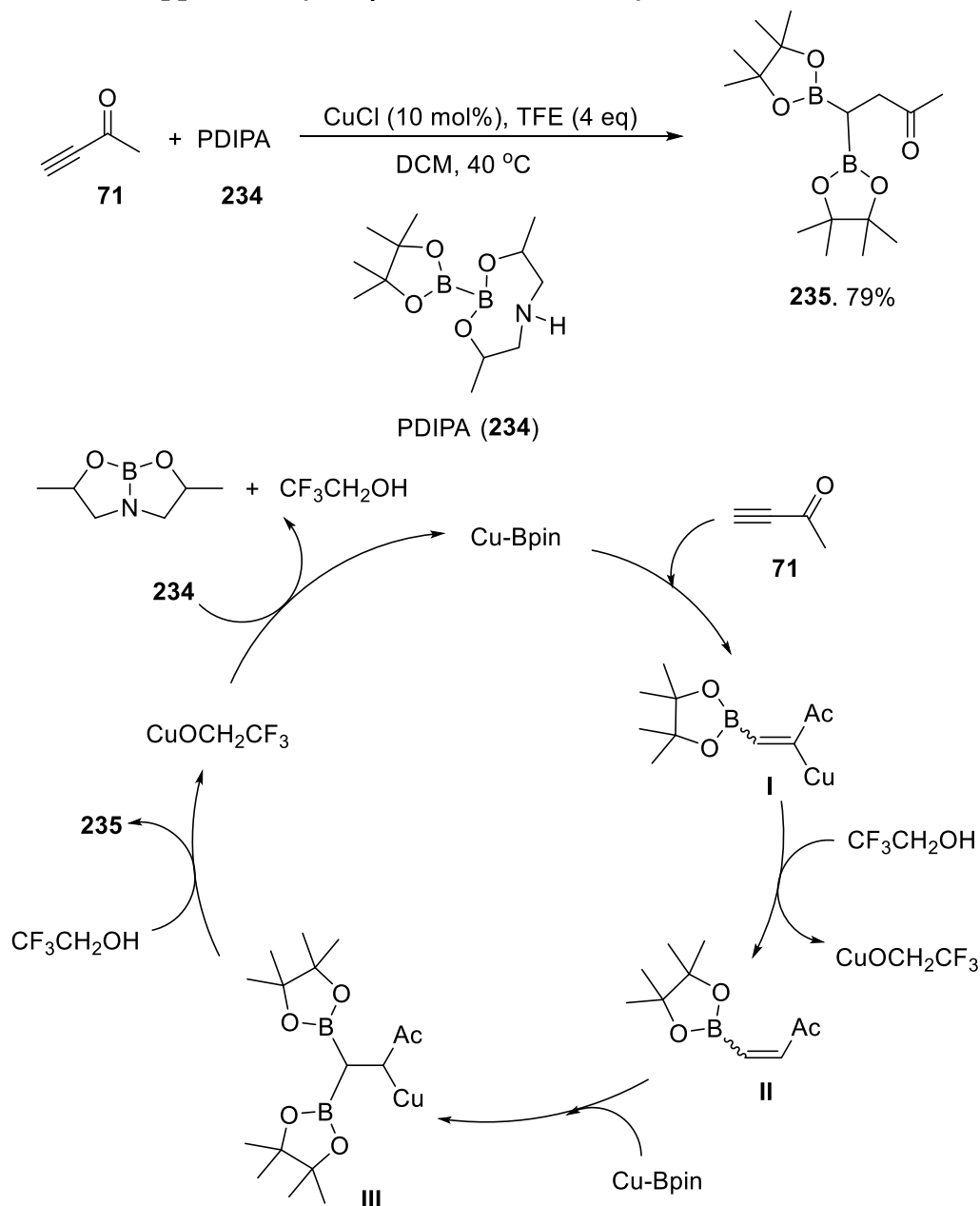

3.1.2. Carbon Nucleophiles. The carbon nucleophiles are structurally among the most versatile that have been applied in conjugate addition to ynones. In most cases basic conditions are required, but in the presence of certain structural motifs, the reaction can also be facilitated by a protic or a Lewis acid. Most reactions have been performed with a stoichiometric amount of the organometallic reagent, but in recent years metal-catalyzed transformations have become more important.

3.1.2.1. Organometallic Reagents. Several reagents containing a more or less complex carbometalated substructure as the reactive site have been applied to alkylate

the β carbon atom of conjugated ynones. In order to achieve regiospecific attack of the carbon-carbon triple bond in the presence of the keto moiety (as well as other reactive, but more or less protected functional groups), the variety of metals is small and essentially limited to copper, palladium, nickel and a copper/tin cluster, although a small number of lithium reagents have been applied as well. The mechanism of the reaction for the transformation **71** to **236** has been studied extensively and a summary, inspired by a study of Nakamura and co-workers,³⁰⁶ is given in Scheme 109 involving intermediates **I** to **IV**.

Scheme 109. Mechanism for Conjugate Addition of Cuprates to Ynones 71

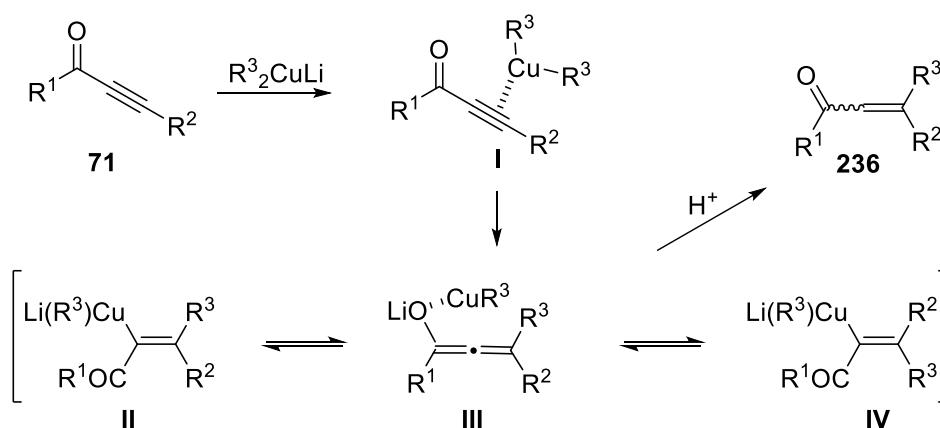

The reagent most frequently used is lithium dimethylcuprate (the Gilman reagent), which β -methylates the ynone moiety and furnishes the corresponding β -methyleneones, in most cases in good to excellent yields. The stereoselectivity of the reaction is often low, but sensitive to the substituents attached to the ynone as well as how the reaction is quenched.^{50,307} The first aspect is clearly reflected in the methylation of a series of silyl ether-protected 1,1-diethoxy-5-hydroxy-3-alkyn-2-ones (**237**), which gave 5-(*t*-butyl)diphenylsiloxy-1,1-diethoxy-4-methyl-3-alken-2-ones (**238**), in up to quantitative yield, with an *E/Z* ratio that increased as the steric congestion in the γ position increased (Scheme 110).^{308,309} The lack of specificity is in fact expected because the intermediates, copper enolates, have appeared to equilibrate at a rate which is sensitive to solvent, temperature, concentration, complexation and reaction time.^{308,310} As a result, even in cases when the cuprate addition to the triple bond is believed to be stereospecific,^{85,308} the corresponding α,β -unsaturated carbonyl compounds **238** have been obtained with *E/Z* ratios approaching 1:1. It should be mentioned that if the silyl group is replaced by acyl moieties, intramolecular trapping of the intermediate allenolate takes place so that furans are formed, in good yields, instead of the corresponding conjugated enones.³⁰⁹

Scheme 110. Conjugate Addition of Lithium Dimethylcuprate to Ynone 237

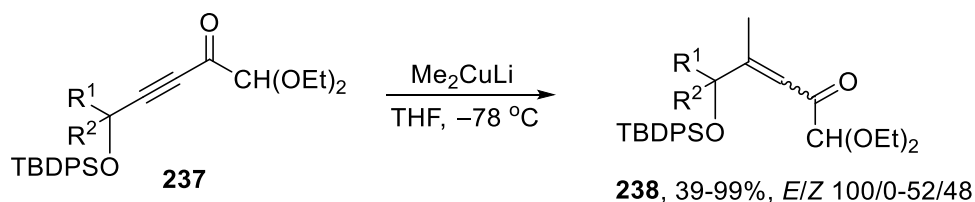

$\text{R}^1, \text{R}^2 = \text{H}, \text{H}; \text{Me}, \text{H}; i\text{Pr}, \text{H}; n\text{Hex}, \text{H}; \text{Me}, \text{Me}; (\text{CH}_2)_5$

When the 1,1,2,2-tetraethoxyethyl moiety in **237** is replaced by a triphenylsilyl group, the conjugate addition of Me_2CuLi and other cuprates to **239** becomes stereoselective and affords the corresponding α,β -unsaturated acylsilane **240** with *E* configuration in high yield irrespective of the cuprate used (Scheme 111).³¹¹ The polarisation of the C-Si bond and the ability of silicon to stabilise both positive and negative charges probably contribute to the specificity. These properties are also taken advantage of synthetically; by treating **240** with tetrabutylammonium fluoride (TBAF) the corresponding 2-alkenals **241** were obtained in good to excellent yields with complete retention of configuration (Scheme 111), making **239** a good synthetic equivalent to the propynal moiety.

Scheme 111. Conjugate Addition of Lithium Cuprates to Acyltriphenylsilane **239**

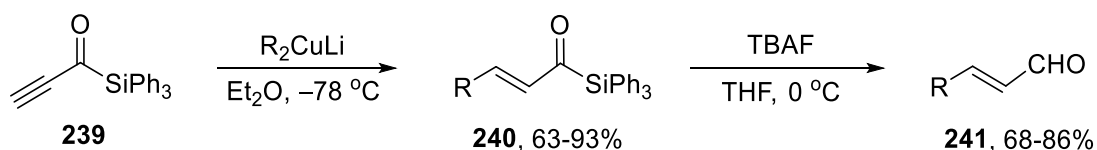

$\text{R} = \text{Me}, n\text{Bu}, \text{Ph}, \text{CH}_2=\text{CH}, \text{Me}_2\text{C}=\text{CH}, n\text{BuCH}=\text{CH}$

Conjugate addition of dimethylcuprate to ynones has been used successfully to introduce β -methylated conjugated trisubstituted enones in specific positions in the synthesis of several macrocyclic natural products. In most cases the methylation has been carried out by Me_2CuLi addition to alkyl alkynyl ketones before cyclization was attempted. The stereoselectivity is generally low even when the alkyl and alkynyl groups are sterically demanding and should conceivably have favored the formation of the *E* alkene. Thus, in their synthesis of the okadaic acid architecture Forsyth and co-workers performed conjugate addition to alkynones **120** and obtained nearly quantitative yields of enones **242**, as an approximate 1:1 mixture of the *E* and *Z* isomers.¹¹² However, when the *E* isomers of the latter enones were exposed to acidic conditions (TsOH, benzene), isomerization to the corresponding *Z* isomers occurred, and this made it possible to obtain spiroketals **243** in 31 to 76% yield (Scheme 112).

Scheme 112. Synthesis of Spiroketal 243 by Conjugate Addition of Me₂CuLi to Yrones 120

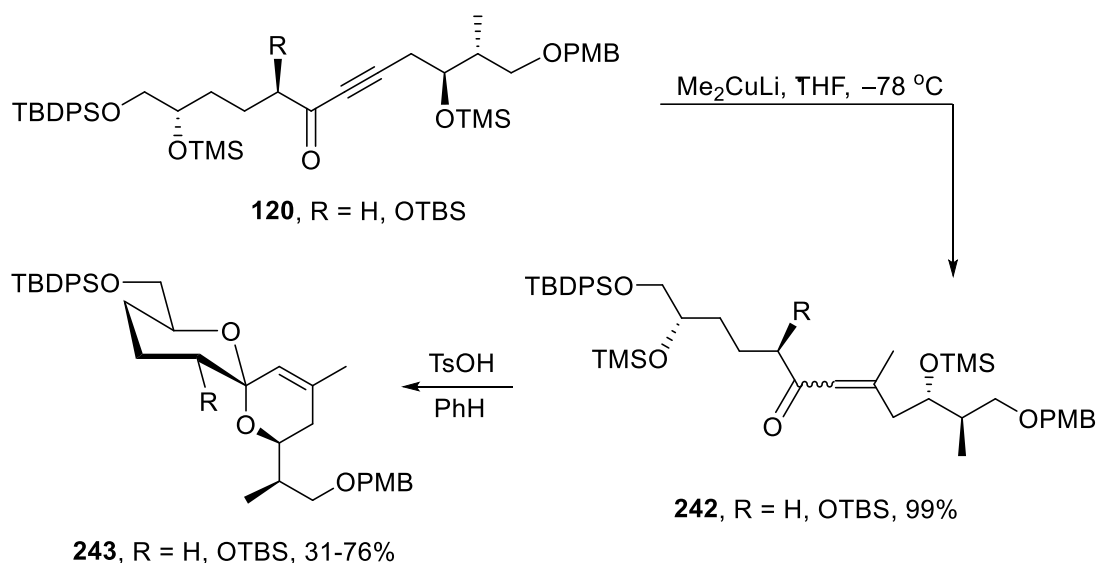

A related example is the formal synthesis of the macrolide aglycon of aurside A and B which are two glycosidated macrolactones isolated from the sea hare *Dolabella auricularia*. When ynone **244** was subjected to Me₂CuLi at -78 °C, the corresponding conjugated enone **245** was obtained in better than 50% yield as a 1.6:1 mixture of the *E* and *Z* isomers when quenching was carried out with aqueous NH₄Cl (Scheme 113).⁵⁰ This outcome was similar to results obtained with less complex yrones.⁴⁹ The *E* isomer required to complete the synthesis was isolated in 31% yield, and when deprotected with TASF and subsequently subjected to the Yamaguchi lactonization protocol, the aurside aglycon was isolated.⁵⁰

Scheme 113. Preparation of Intermediate 245 in the Synthesis of the Auriside Aglycon

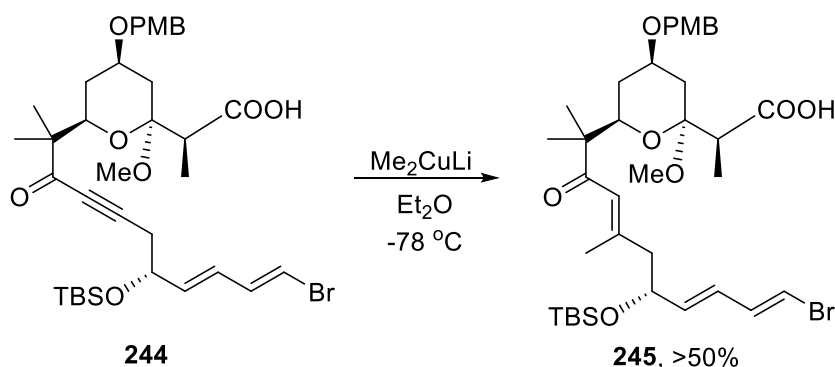

Conjugate addition before cyclization was also the selected strategy of Thomas and co-workers in their attempts to synthesize phomactins, a group of diterpenes of interest as platelet activating factor antagonists. A model study was first carried out by reacting an ynone with Me₂CuLi, and this afforded the corresponding enone in 77% yield.^{33,312} When yrones **246** and **247**, suitable substrates for the preparation of phomactin B2, were applied under the same conditions, even better results were obtained as both addition

products, **248** and **249**, respectively, were isolated in better than 90% yield, albeit as *E/Z* isomeric mixtures (Scheme 114). The yields of the desired *Z* stereoisomers were lower than 50% under any conditions, but surprisingly, subsequent treatment of *E/Z* mixtures of **248** and **249** with iodine increased the *E* predominance of the former and the *Z* predominance of the latter.³³

Scheme 114. Synthesis of Intermediates 248 and 249 Used to Prepare Phomactin B2

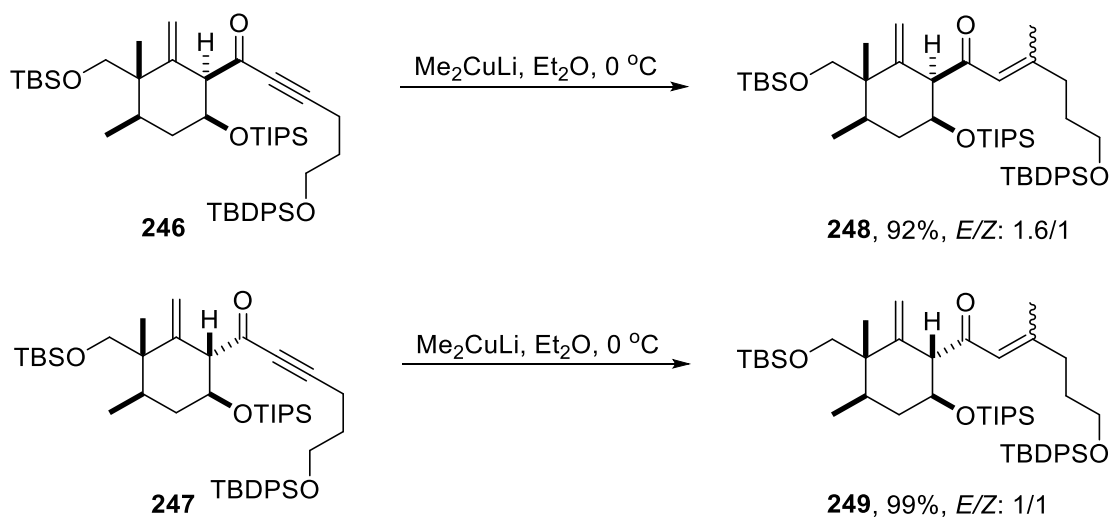

Unlike Thomas and co-workers, Rawal and co-workers wanted to introduce the methyl group β to the carbonyl group in phomactins B2, C and D after ring closure. This step has been carried out by carbonylative alkyne-enol triflate coupling in the presence of a Pd catalyst.³¹³ The resulting ketone **250** contains both a conjugated enone and an ynone and therefore represents a regiochemical challenge since cuprates are known to undergo conjugate addition to both moieties. However, in this event, Me_2CuLi gave products due to attack of the alkyne exclusively (Scheme 115). The resulting doubly conjugated enone **251** was obtained in excellent yield, but it appeared to be a $\sim 2.5:1$ mixture of the *Z* and *E* isomers which means that the undesired isomer predominated. Attempts to increase the proportion of the *E* isomer by performing photoisomerization under various conditions failed.

Scheme 115. Conjugate Addition of Me_2CuLi to Ynone 250 in the Synthesis of the Phomactin Core

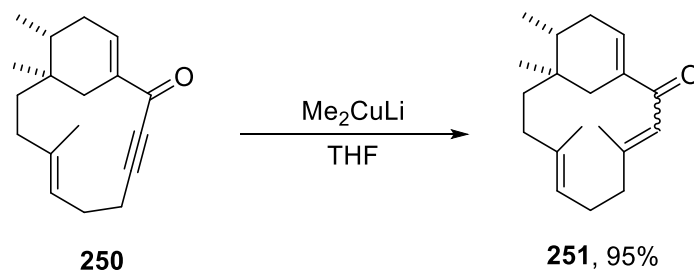

Conjugate addition with the Gilman reagent to cyclic ynones has also been used by Marshall and co-workers to prepare several cembranolides, which are constituents of various soft corals. The reaction was carried out with two 2-substituted 5,9-dimethylcyclotetradec-5,9-dien-13-ynone derivatives (**252**), and this furnished the corresponding 13-methylated triene **253** (Scheme 116).^{307,314} The 13*E*/13*Z* ratio was approximately 1:1 when the reaction was quenched with water or aqueous NH₄Cl, but subsequent treatment with lithium isopropylthiolate effected enone equilibration which gave the *E* isomer in excellent yield.

Scheme 116. Conjugate Addition of the Gilman Reagent to Ynones **252 in the Total Synthesis of Cembranolides**

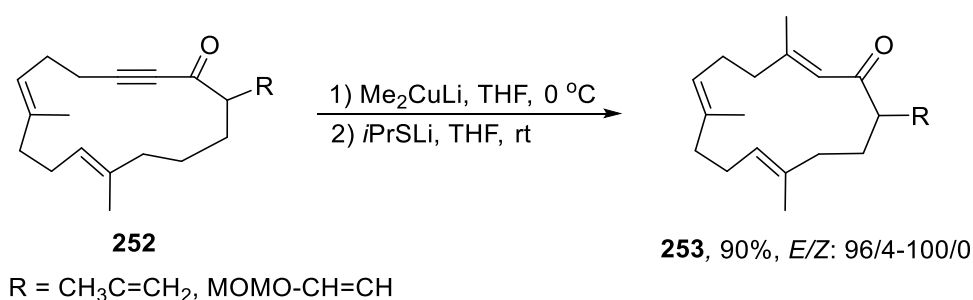

As part of a mechanistic investigation, Tanner, Norrby and co-workers studied conjugate addition of carbocuprates R¹Cu(CN)Li to two ynones (**71**). The results obtained were interesting; when 3-pentyn-2-one (**71** with R = Me) was subjected to *t*BuCu(CN)Li, the *E* stereoisomer of enone **236** was obtained in 70% yield whereas only traces of the corresponding *Z* isomer were formed (Scheme 117).³¹⁵ However, when MeCu(CN)Li was reacted with 5,5-dimethyl-3-hexyn-2-one (**71** with R = *t*-Bu), *E*-**236** was obtained in trace amounts only whereas *Z*-**236** was not detected at all. These observations have been rationalized by DFT calculations which clearly suggest that the stereochemical outcome is determined by the relative stabilities of the postulated vinylcuprate intermediates, rather than by stereoselective protonation of the allenolate intermediates.³¹⁵

Scheme 117. Carbocupration of Ynones **71 with R¹Cu(CN)Li**

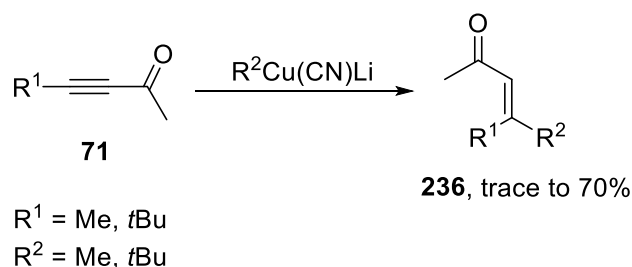

Simple alkyl lithium compounds, either stable reagents or less stable compounds generated *in situ*, react in general in a 1,2 fashion with conjugated ketones. Nevertheless, a few reactions with some highly substituted resonance-stabilized carbanions have been

reported by Shi and co-workers.³¹⁶ The reactions were carried at low temperature by adding ynones **71** to carbanions obtained by treating tetrasubstituted vinylidenecyclopropanes **254** with lithium diisopropylamide (LDA) at -78 °C. The composition of the reaction mixtures appeared to depend on the structure of the ynone (Scheme 118). When 3-butyn-2-one (**71**, $R^3 = H$, $R^4 = Me$) and ethynyl phenyl ketone (**71**, $R^3 = H$, $R^4 = Ph$) were used, one product was formed in a two-step domino addition process, the polyunsaturated conjugated hydroxyenone **255**, respectively. However, when ketones with an internal triple bond were reacted, the picture became more complex. Using 1,3-diphenylprop-2-yn-1-one (**71**, $R^3 = R^4 = Ph$) and 1-phenyl-3-(trimethylsilyl)prop-2-yn-1-one (**71**, $R^3 = TMS$, $R^4 = Ph$) mixtures of the expected domino-addition product **255** (major) and a tertiary alcohol **256** (minor) were obtained. On the other hand, when hex-3-yn-2-one (**71**, $R^3 = Et$, $R^4 = Me$) was used as electrophile, the outcome was carbanion dependent. When the carbanion source **254** contains only aryl substituents, only conjugate addition and formation of the Michael adduct **257** occur. But if one of the aryl groups **254** is replaced by a methyl group, mixtures of **256** and **257** were obtained. Finally, if in **71**, $R^1 = nBu$ and $R^2 = Ph$, conjugate addition predominated and the expected Michael adduct **257** was formed, albeit only in 25% yield. A conceivable mechanism for the formation of **255-257** is depicted in Scheme 119: first the carbanion (**I-III**) attacks the substrate in a Michael fashion and form an allenolate (**IV**), which undergoes a 1,2-addition to another molecule of ynone and forms a polyunsaturated conjugated hydroxyenone **255**. Hydrolysis of **IV** would yield products **257**. On the other hand, organolithium intermediates **I-III** reacted with ynones **71** ($R^3 = H$) at the carbonyl group giving trienes **256**.

Scheme 118. Reaction of Ynones 71 with Different Lithiated Vinylidenecyclopropanes 254

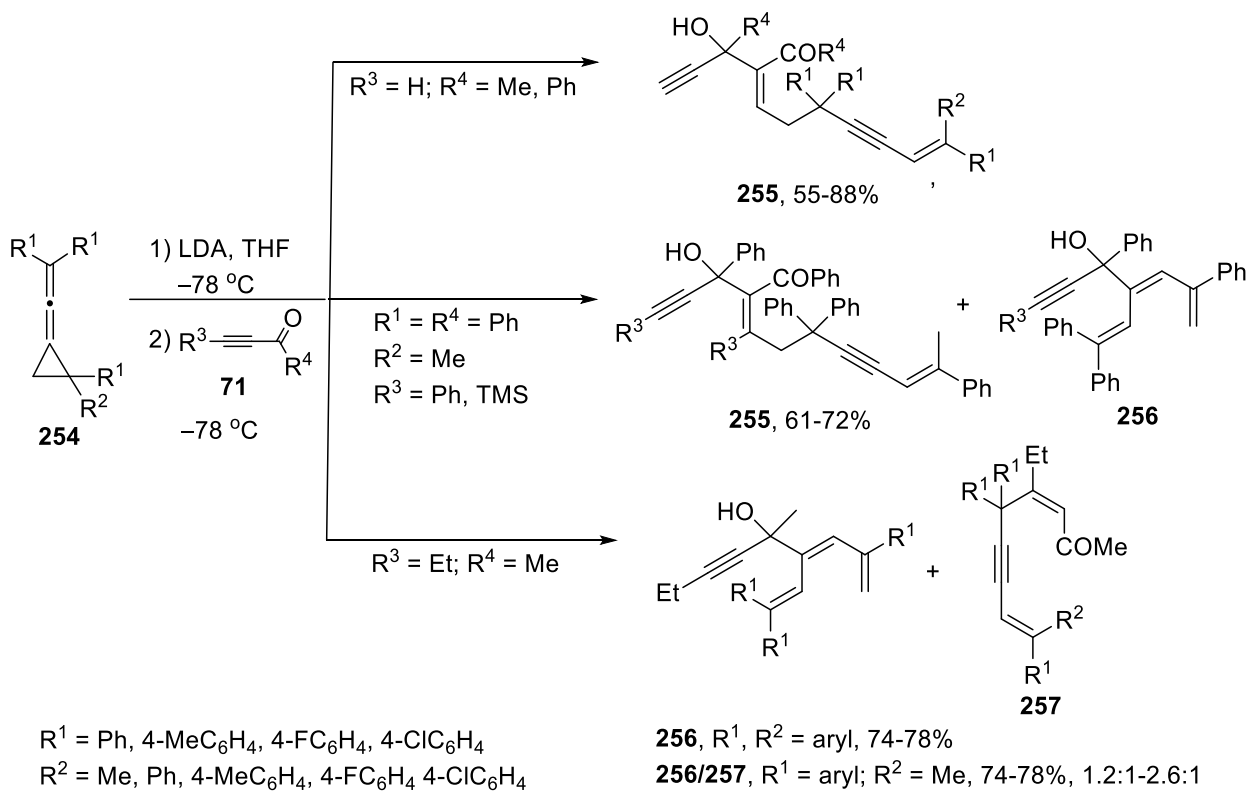

Scheme 119. Plausible Mechanism for the Reaction of Lithiated Vinylidenecyclopropanes 254 with Ynones 71

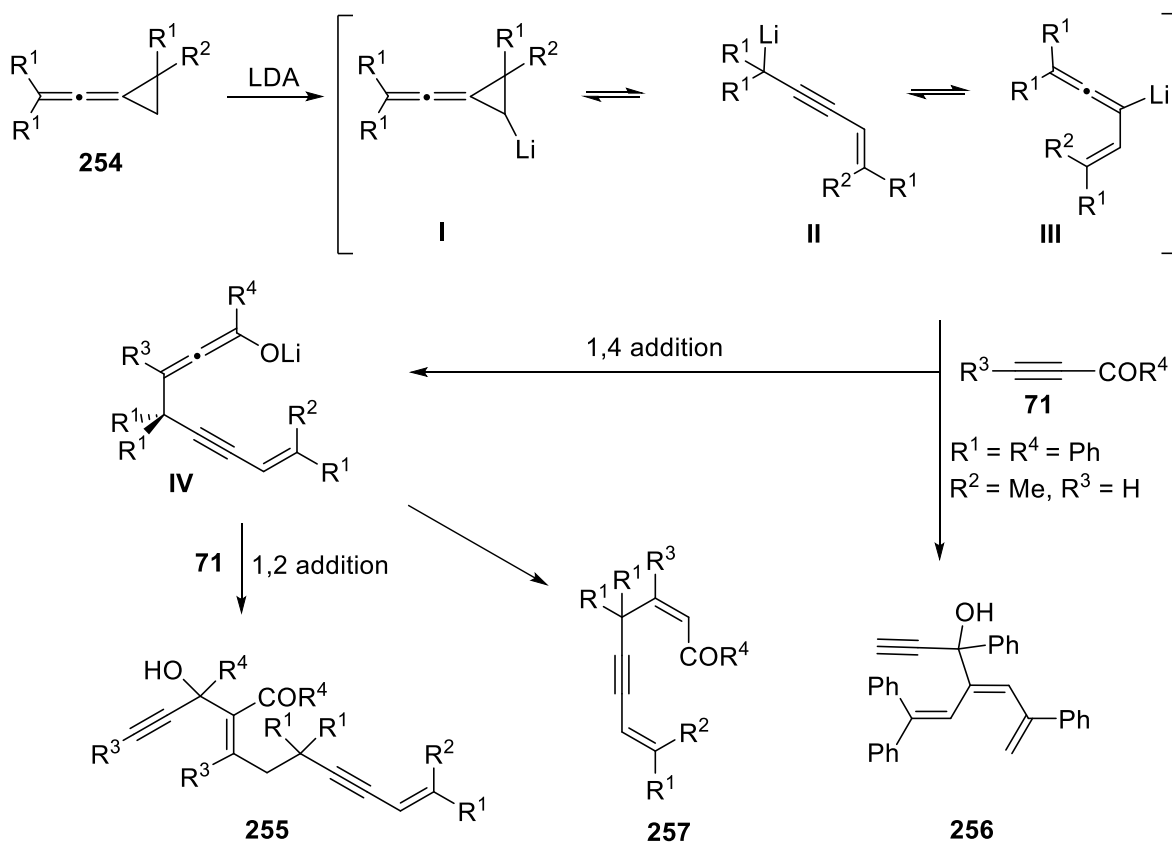

In conclusion, conjugate addition of alkanides to ynones has mainly been performed with simple cuprates (R_2CuLi) and almost exclusively with the Gilman reagent (Me_2CuLi). In general, the resulting β -R- α,β -enones are formed in good yield as *E/Z* mixtures. The reaction has been applied successfully to introduce methyl groups in specific positions in complex molecules.

3.1.2.2. Metal Catalysis. Conjugate addition to ynones has also been carried out successfully by metal catalysis. Whereas palladium and nickel have been applied to achieve intermolecular reactions by modifying the structure and reactivity of the carbanion, gold and silver catalysts have almost exclusively been used to facilitate cyclization by intramolecular transformations made possible by increased electrophilicity of the carbon-carbon triple bond due to metal complexation to the alkyne moiety.

An elegant example was published by Hanzawa and co-workers who used Pd catalysis to acylate a few non-terminal ynones (**71**) by using acylzirconocene chlorides **258**, made by carbonylation of alkenes and alkynes, as the acyl source. The regioselectivity of the reaction was sensitive to the catalyst employed. When the palladium complex contained triphenylphosphine ligands, regiospecific formation of alk-2-en-1,4-diones **259** occurred (Scheme 120).^{317,318} On the other hand, application of $Pd(acac)_2$ and $PdCl_2(CH_3CN)_2$ under otherwise identical conditions slowed down the conjugate addition and gave **259** in only 5-15%; the main product was the corresponding 1,2-adducts **260** as illustrated with a specific case in Scheme 120.³¹⁸ A catalytic cycle for the formation of **259** and **260**, included in Scheme 120, consists of four integrated processes: (a) electron transfer from Pd(0) to **71**; (b) formation of Pd-allenyl complex **I**; (c) transmetalation, and (d) reductive elimination of Pd(0) with concomitant formation of **259** or **260**. The change of reaction course when **258** is a conjugated enone is noteworthy; tandem Michael additions take place giving allenates **261** which afforded mixtures of enones **259** and mainly 3-acylcyclopent-2-enones **262** in 21–63% yield (Scheme 121).³¹⁷

Scheme 120. Pd-Catalyzed Acylation of Ynones 71 Using Acylzirconocene Chlorides 258

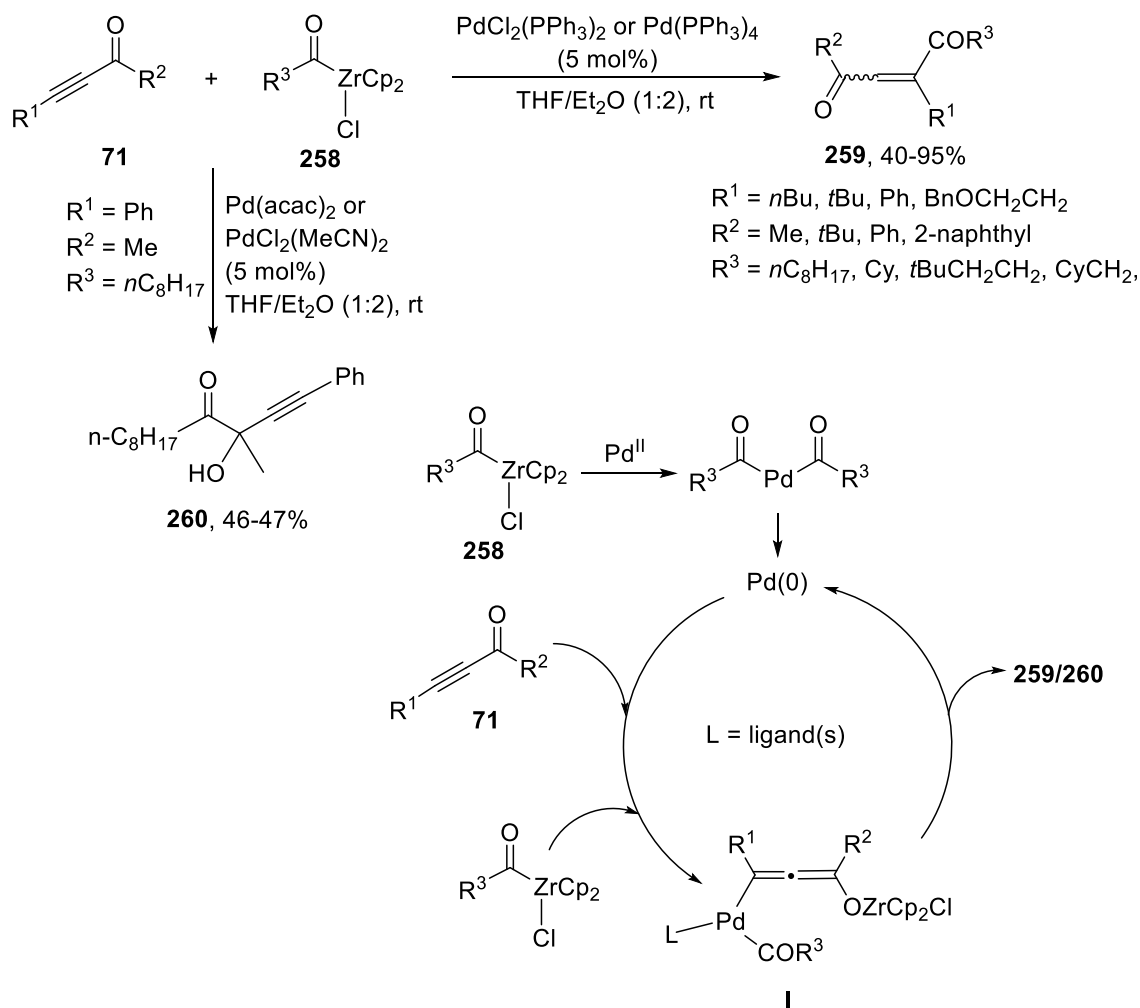

Scheme 121. Pd-Catalyzed Acylation of Ynones **71** Using α,β -Unsaturated Acylzirconocene Chlorides **258**

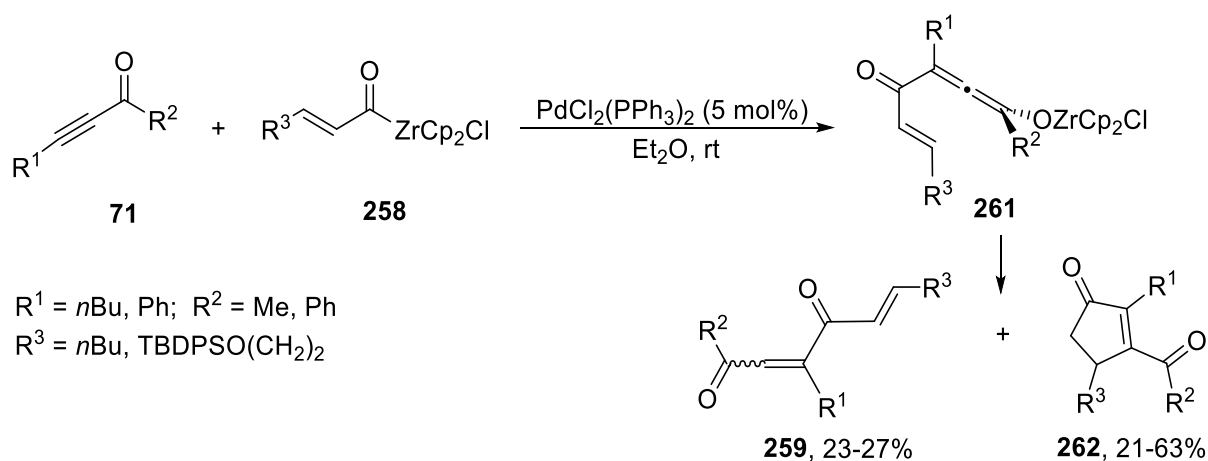

Pd catalysis has also been applied by Marinelli and co-workers to synthesize 2-arylalk-1-enyl ketones by hydroarylation of the corresponding ynones,³¹⁹ but the outcome is sensitive to several parameters, the most important being the aryl source, the nature of the Pd complex, and the presence of other reactive functional groups. When aryl halides and triflates were used, the yields and the regioselectivity were low to moderate, but great

improvements were made when the aryl source was arylboronic acids. They studied the hydroarylation of β -(2-aminoaryl)- α,β -ynones **200** and discovered that the primary products suffered cyclization and formed mixtures of 3-arylquinolines **263** and 4-arylquinolines **264**. The outcome appeared to be catalyst dependent; thus, the **263/264** ratio varied between 75:25 (Pd(OAc)₂/tBu₃P) and 98:2 (Pd₂(dba)₃/dppe) and the total yield from 18 to 92%. The optimum combination of regioselectivity and yield was achieved with Pd(OAc)₂/dppe, and when this catalyst was applied, a large number of 4-arylquinolines were synthesized (Scheme 122). The structure and electron distribution of the transition state(s) were investigated by computational methods, which showed that the observed regioselectivity is in accord with the difference in calculated energy barriers for two alternative insertion paths of the alkyne moiety.³¹⁹

Scheme 122. Pd-Catalyzed Synthesis of 4-Arylquinolines 263 from Ynones 200 and Boron Reagents

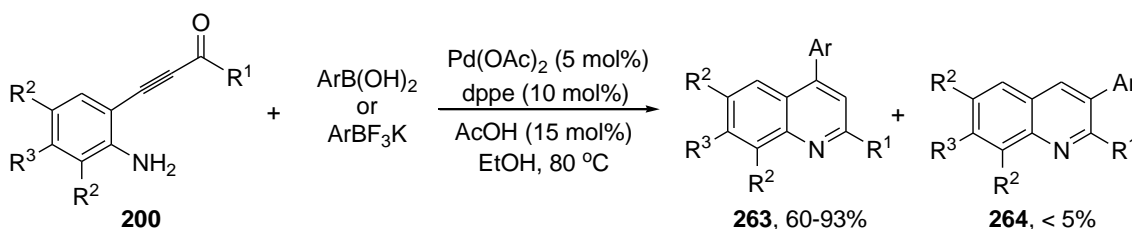

R¹ = 4-MeOC₆H₄, 1-naphthyl, 2,4-Me₂C₆H₃, 2-MeOC₆H₄, 4-NCC₆H₄, 4-ClC₆H₄, 4-AcC₆H₄,
4-*t*-butylcyclohex-1-enyl
R² = H, F; R³ = H, CF₃
Ar = Ph, 4-MeSC₆H₄, 4-FC₆H₄, 3-AcC₆H₄, 3-MeOC₆H₄, 4-MeC₆H₄, 1-naphthyl

Nickel-catalyzed conjugate addition of cyanide, an efficient reaction with conjugated enones, has been extended to α,β -ynones by Arai and co-workers.^{9,320} The cyanide source was Me₃SiCN (TMSCN), which reacted smoothly when catalyzed by Ni(COD)₂ and furnished the corresponding β -cyanotrimethylsilyloxyallene **265** (Scheme 123). The allenes were not isolated, except in one case (when *t*-BuMe₂SiCN was used and afforded the corresponding allene in 64% yield) but characterized by proton NMR prior to quenching with either a proton source or *N*-bromosuccinimide (NBS). Protic work-up gave the corresponding β -cyanoenone **266** as an isomeric mixture, with no stereoselectivity when hydrochloric acid was used, but with an *E/Z* ratio of up to 11/89 when acetic acid was employed. Quenching with NBS, on the other hand, was much more successful; with one exception the yield of the corresponding α -bromo- β -cyanoenone **267** was excellent and in most cases an olefin *Z/E* ratio better than 99/1 was obtained.^{9,320} A plausible mechanism for the reaction involving intermediates **I-III** was presented (Scheme 123).

Scheme 123. Ni-Catalyzed Conjugate Addition of TMSCN to Ynones 71

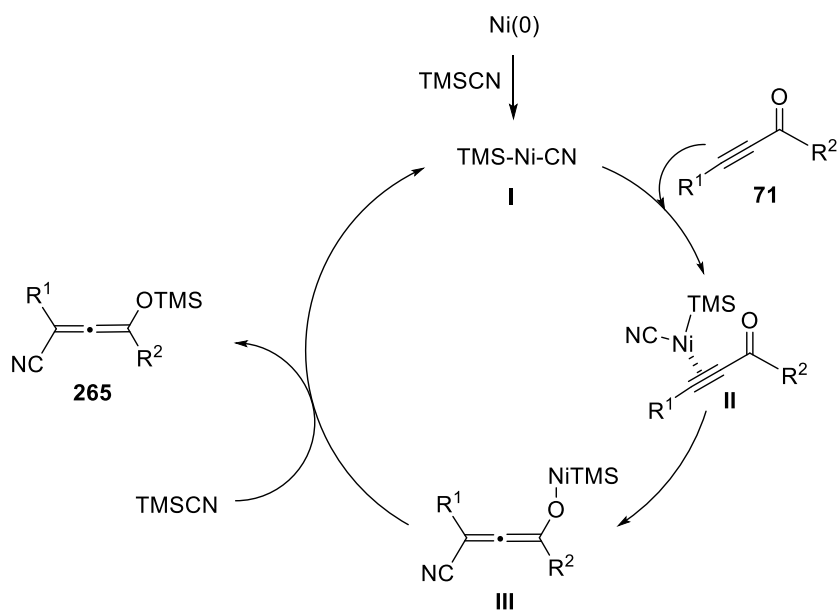
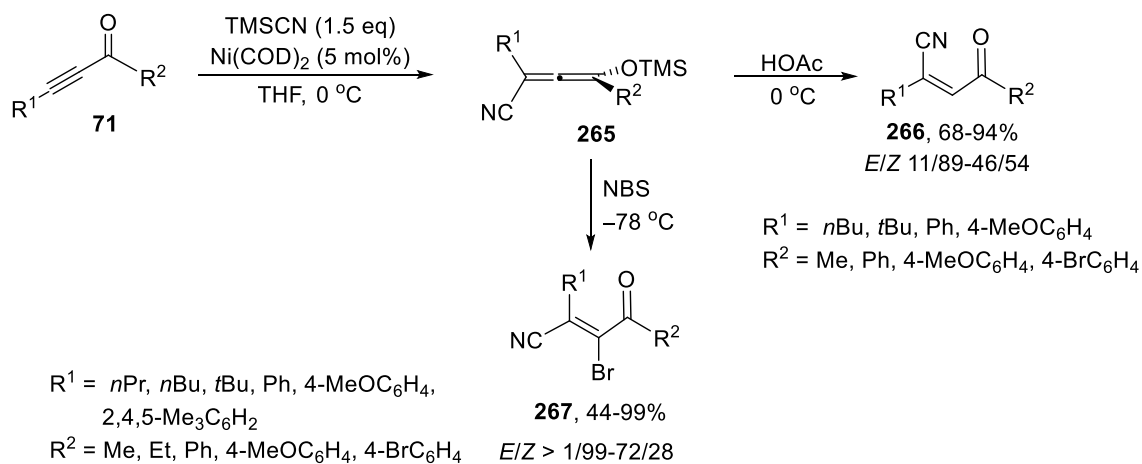

Menon and Banwell, on the other hand, employed gold-complex catalysis to effect intramolecular hydroarylation of terminal alkynes under exceptionally mild conditions.¹⁸ The best results were obtained with Echavarran's Au(I) complex **268**, and these results subsequently prompted the use of this catalyst to achieve the synthesis of the bicyclic moiety **269** in the furanosesquiterpene crassifolone (Scheme 124).¹⁸ Conceivably, the reaction involves initial auration of C-2 in the furan ring which subsequently attacks the uncongested β terminus of the tethered ynone **7**.

Scheme 124. Au(I)-Catalyzed Intramolecular Cyclization of Ynone 7: A Key Step in the Synthesis of Crassifolone

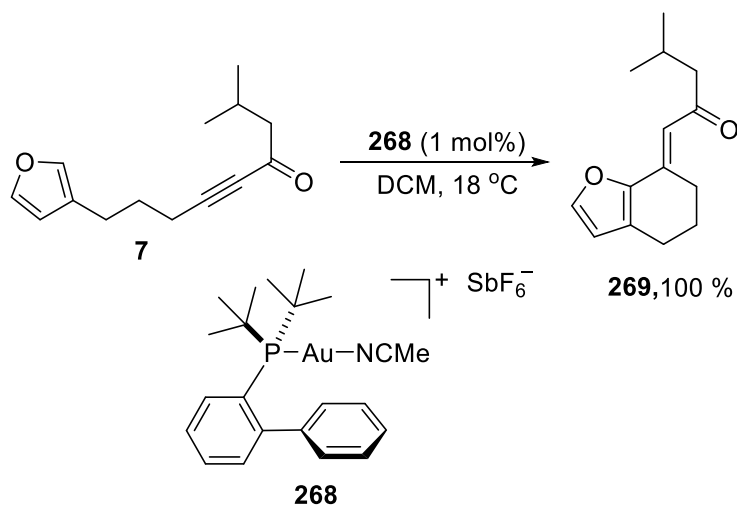

Taylor and co-workers have carried out similar studies with 3-butyn-2-one derivatives (**270**) that have an electron-rich aromatic moiety attached to C-1 and an aryl or alkyl group at C-4. Most of the compounds studied have an indol-3-yl group attached to C-1, and when they are treated with Brønsted, Lewis, and π acids to activate the carbon-carbon triple bond and facilitate conjugate addition, the most effective catalysts screened were $\text{Ph}_3\text{PAuNTf}_2$, $\text{Cu}(\text{OTf})_2$, AgNO_3 , and AgOTf while triflic acid was ineffective.^{321,322} The final product appeared to be catalyst dependent. Thus, the copper and silver catalysts produced 3,3-disubstituted spirocyclic indolenines **271** in excellent yields via intermediate **I** (Scheme 125). The Au(I) catalyst induced primarily the same reaction, but when $\text{Ph}_3\text{PAuNTf}_2$ was applied, **I** is expected to be unstable, undergo 1,2-migration, and ultimately form carbazoles **272** via intermediates **II-IV** (Scheme 126), and this indeed occurred. The vinyl-gold intermediate apparently plays a key role in the reaction because when the corresponding 3,3-disubstituted spirocyclic indolenines **271** were treated with $\text{Ph}_3\text{PAuNTf}_2$ under the same conditions, no reaction takes place. It is also noteworthy that when the indole moiety in **270** is replaced by other electron-rich aromatic motifs such as anisole, pyrazole and 2-methylbenzofuran, dearomatizing spirocyclization still occurs and gives the predicted spiro compounds **273-275**, respectively, in excellent yields (Scheme 127).^{321,323-326}

Scheme 125. Ag-Catalyzed Spirocyclization of Indolyl Ynones 270

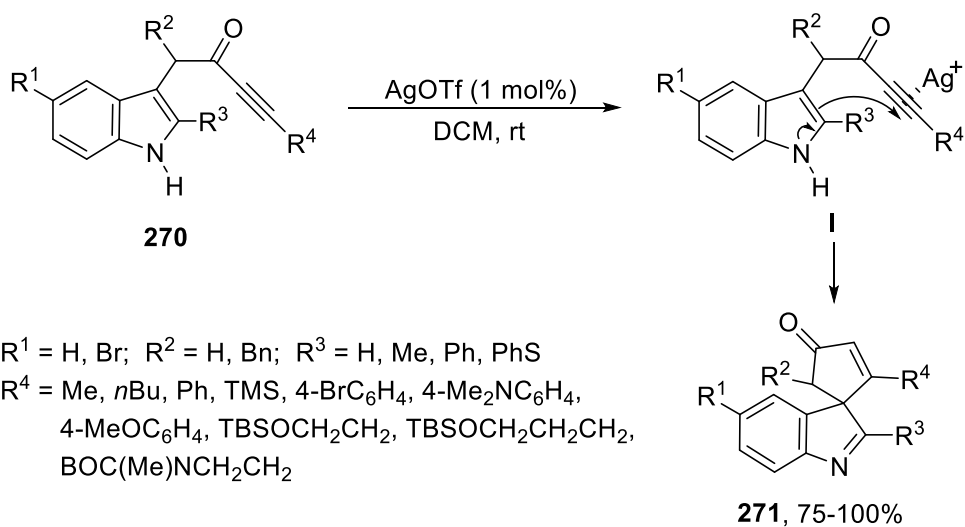

Scheme 126. Au(I)-Catalyzed Cyclization of Indolyl Ynones 270

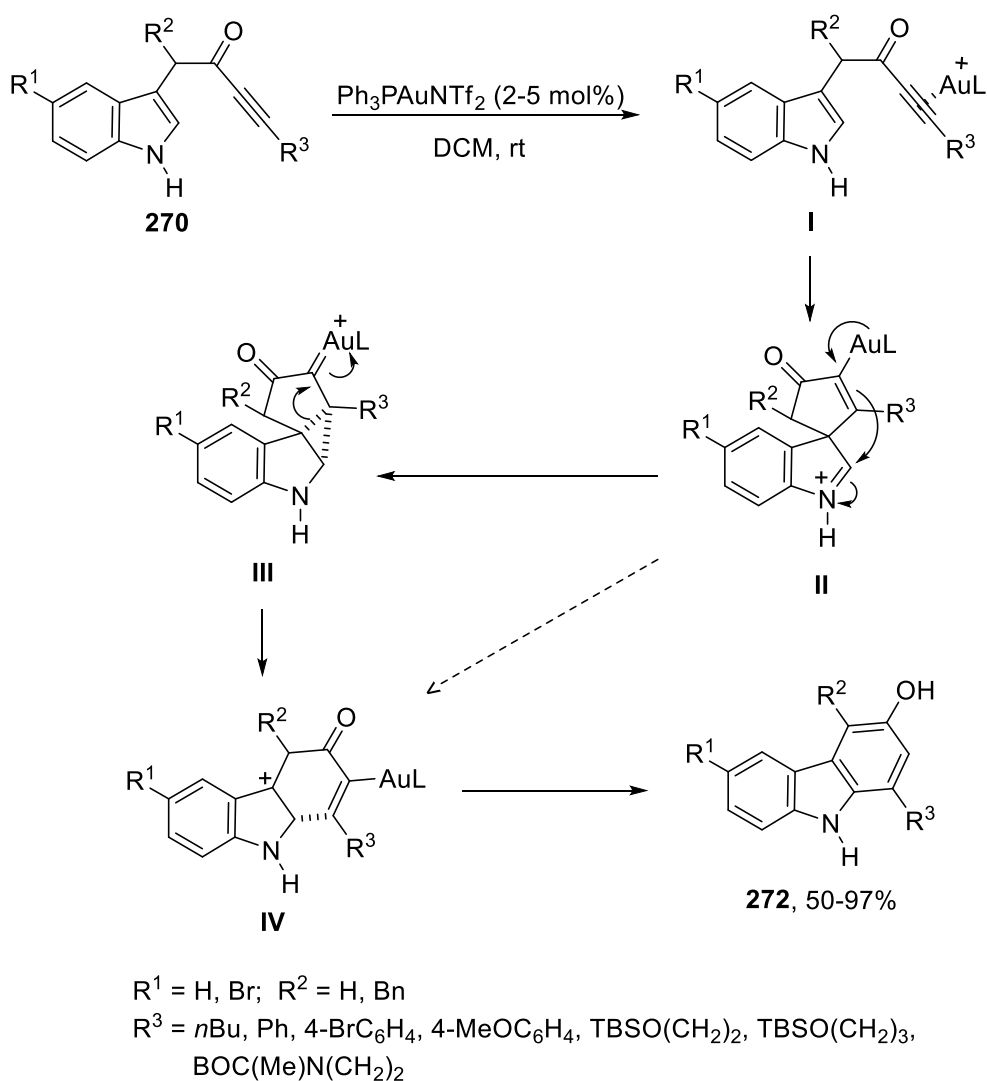

Scheme 127. Metal-Catalyzed Spirocyclization of Yrones **71**

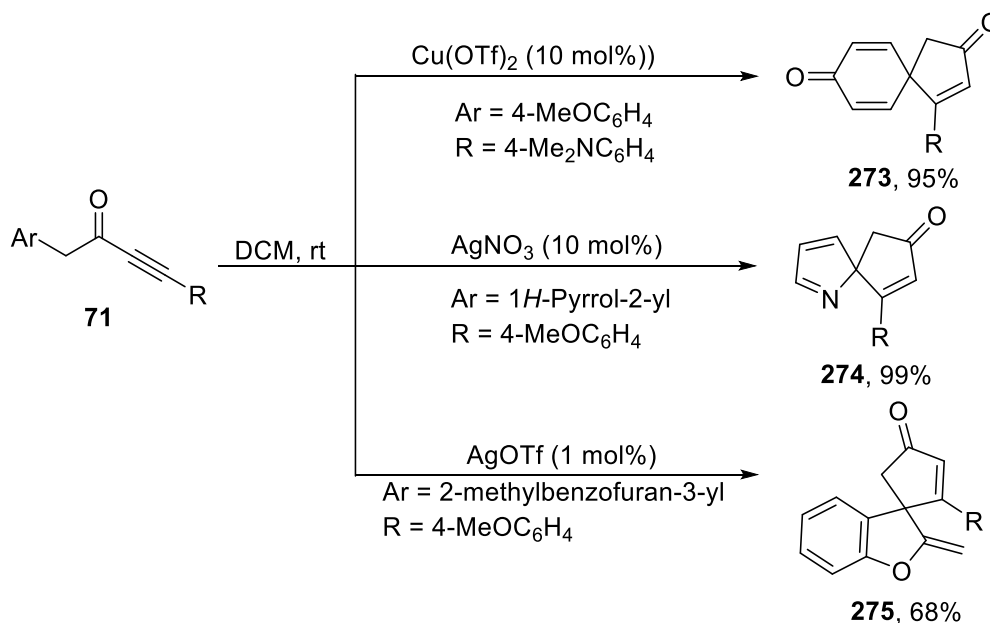

Generation of spiro compounds leads to formation of a new stereocenter and by including a chiral ligand in the reaction mixture, it was envisaged that asymmetric induction would take place. Preliminary experiments using Ag(I) salts of chiral phosphoric acids (CPAs) proved that the idea was correct. Optimization using 1-(indol-3-yl)-4-(4-methoxyphenyl)but-3-yn-2-one **270** showed that the bulkiest CPA gave the highest enantiomeric excess, and when the conditions detailed in Scheme 128 were applied, ee up to 78% was obtained.³²¹ X-ray structure determination proved that the Ag-CPA **276** catalyst gave predominantly spirocycles **271** with *S* configuration.

Scheme 128. Ag-Catalyzed Asymmetric Spirocyclization of Indolyl Yrones **270**

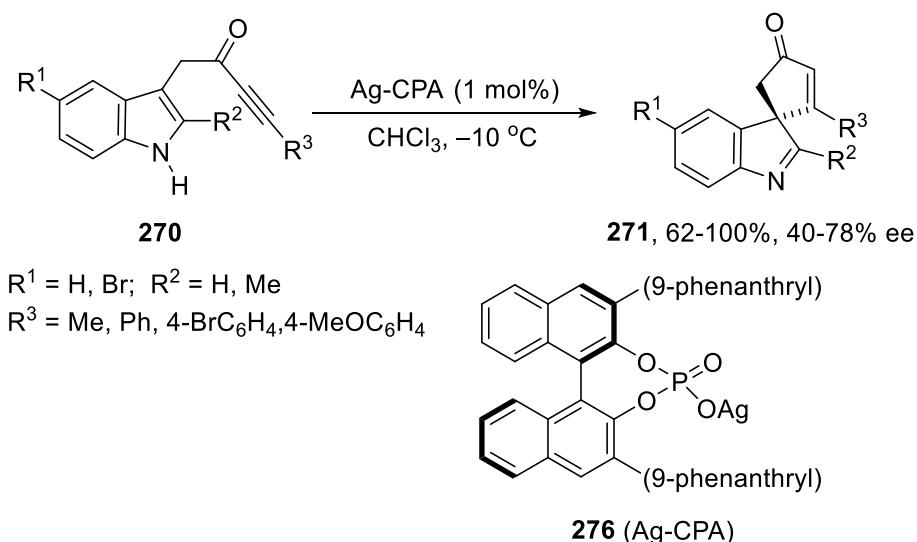

A transformation similar to the former dearomatizing spirocyclization takes place when conjugated yrones with a silyl vinyl ether in a favorable position are treated with phosphinogold(I) complexes, which are soft Lewis acids, which selectively coordinate

with alkynes, alkenes, and allenes, and which facilitate addition of various nucleophiles.³²⁷ By using cationic species of such complexes, Barriault and co-workers succeeded in converting enol ethers **277** to bicyclo[3.3.1]non-3-en-2,9-dione derivatives **278** (Scheme 129).^{328,329} This method was successfully applied to prepare several biologically active polyprenylated polycyclic acylphloroglucinols such as hyperforin, nemorosone, and papuaforins.^{327,330} The study was then expanded to include several catalysts and a range of silyl-protected ynones. Several clear trends emerged from these investigations. Most importantly, the nature of the silyl group attached to the alkyne facilitates or prevents a 1,2-shift of the silyl group before the conjugate addition from the joint intermediate **I**. Silyl group containing several phenyls including triphenylsilyl (TPS) **279** reacted like **277** and furnished only non-migrated products **280** in up to 98% yield, whereas *tert*-butyldimethylsilyl (TBS) and sterically less demanding groups were labile and gave Michael products **281** in somewhat lower yields after 1,2-migration had occurred. It was also proved that the 1,2-silyl migration proceeded by an intramolecular process and probably involved gold(I)-vinylidene intermediate **II** (Scheme 129).³²⁷

Scheme 129. Au(I)-Catalyzed Intramolecular Conjugate Addition of Vinyl Ethers **277 and **279****

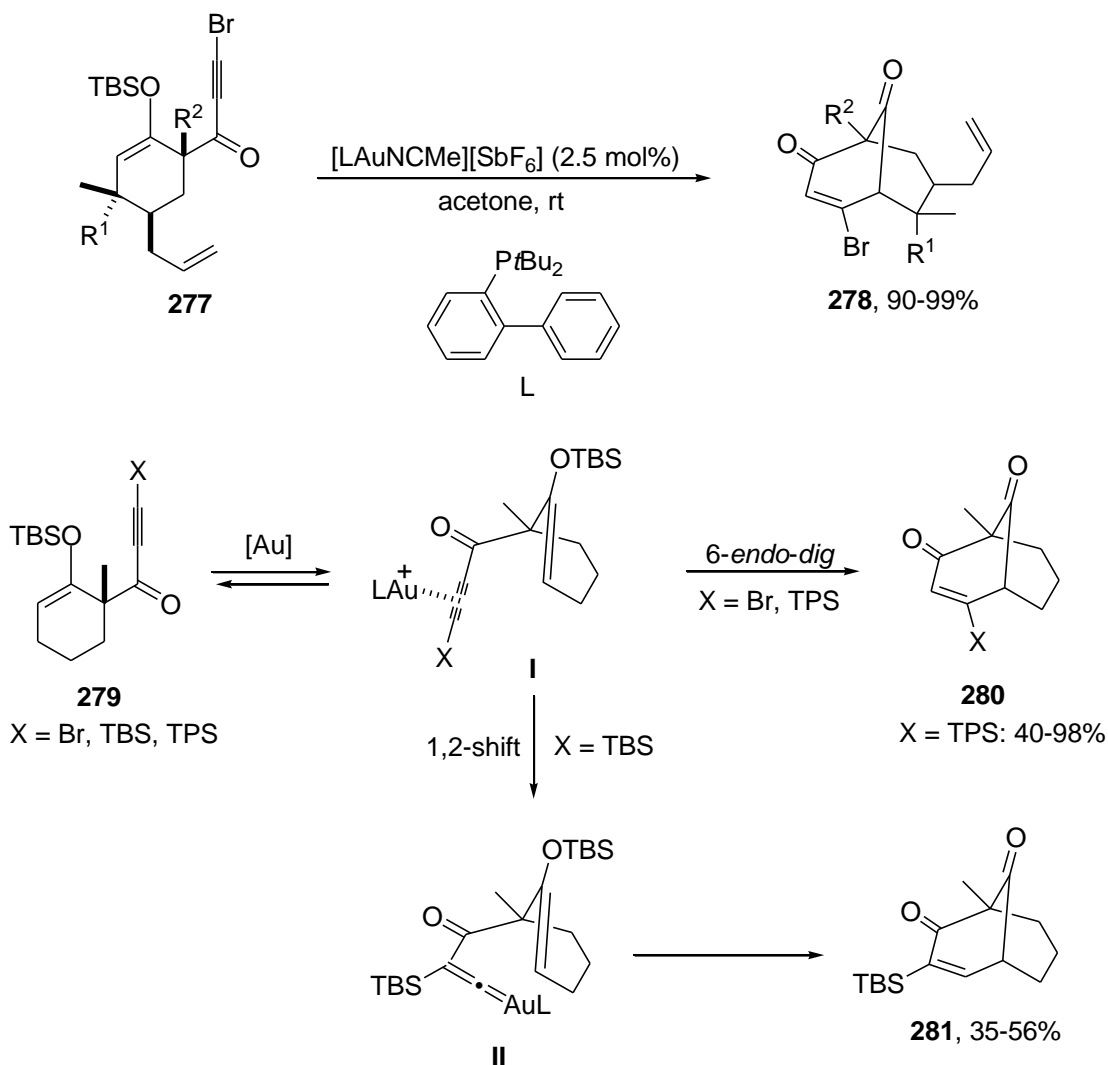

To conclude, the reaction of a variety of carbon nucleophiles with β -C in conjugated ynones has been catalyzed by various metals. The yields are generally good or better. Intermolecular reactions have been performed with Pd catalysts to achieve acylation and Ni catalysis to carry out cyanation. Au(I) and Ag(I) complexes, on the other hand, have been used to activate the triple bond to facilitate intramolecular nucleophilic attack by electron-rich aromatic moieties, leading to formation of a variety of spiro compounds, often in excellent yield.

3.1.2.3. Non-Metallic Catalysis. Some studies of conjugate additions of neutral carbon centres to ynones, made possible by non-metallic catalysis, have also been reported. A pioneering paper was published by Zhang and Larock who observed dearomatizing spirocyclization of 1-(4-methoxyphenyl)-4-phenylbut-3-yn-2-one **282** when it was treated with iodine and furnished 3-iodo-4-phenylspiro[4.5]deca-3,6,9-triene-2,8-dione **283** in almost quantitative yield (Scheme 130).³³¹ The reaction involves iodonium ion **I** which undergoes intramolecular *ipso*-cyclization of an electron-poor alkyne onto an activated arene under extremely mild conditions.

Scheme 130. Iodine-Promoted Cyclization of Ynones 282

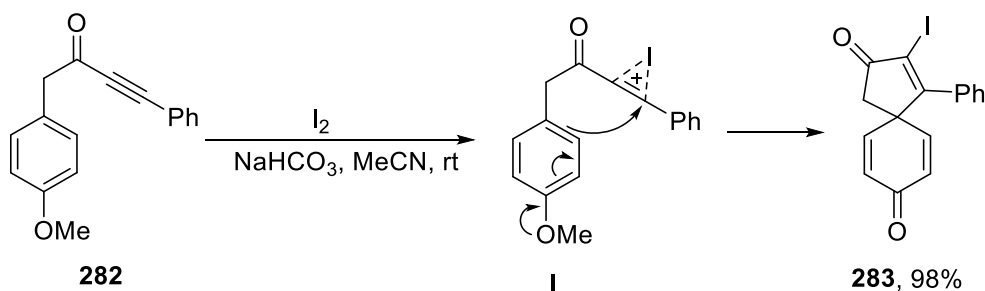

The spirocyclization was employed and expanded by Lovely and co-workers in some exploratory experiments towards the total synthesis of spirocalcaridine A and B.¹⁰⁴ In addition to iodine, they used trifluoroacetic acid (TFA) and *N*-iodosuccinimide (NIS) to generate the electrophilic center. TFA was applied to react 1,4-bis(4-methoxyphenyl)but-3-yn-2-one (**71**, $R^1 = R^2 = \text{OMe}$), which delivered triene-2,8-dione **284** in a straightforward manner in 94% yield (Scheme 131). Application of NIS, on the other hand, was more challenging because the temperature had to be controlled very carefully during the addition of the reagent to avoid formation of naphthols instead; slow addition at room temperature furnished spiroenones **285** whereas fast addition, giving a warm reaction mixture of unspecified temperature, afforded naphthols **286** and **287** instead (Scheme 131).

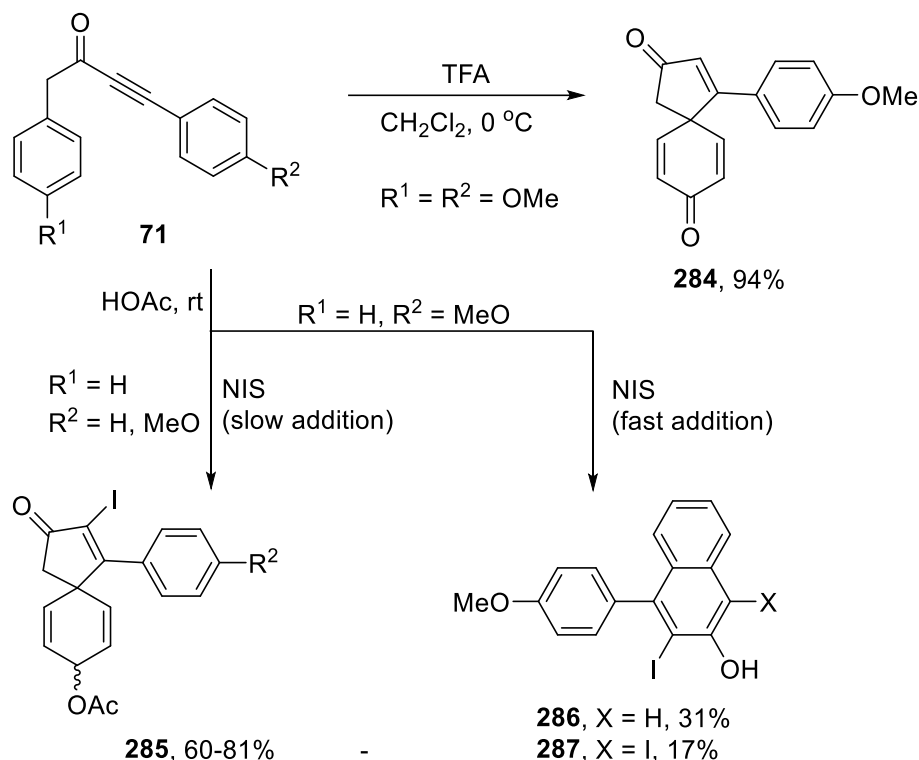
Scheme 131. TFA- and NIS-Promoted Spirocyclizations of Ynone 71

3.1.2.4. Enolates and Related Carbanions. Carbanions, formed by abstraction of a hydrogen with a low pK_a value, are powerful nucleophiles and react with a variety of electrophilic motifs to give a large variety of products. Most such carbanions have been derived from methylene and methine motifs attached to two strongly electron-withdrawing substituents, in most cases acyl, alkoxyacetyl, cyano and sulfonyl groups, but some examples using nitroalkanes have also been reported. In all cases the first reaction is a Michael-type addition to the conjugated alkynones, forming enolate intermediates, but if additional electrophilic sites are present, secondary reactions often take place and lead to other final products than conjugated alkenones.

Maruoka and co-workers treated a number of 1-alkyn-3-ones **71** with a series of α -substituted α -cyanoacetates **288** under basic, phase-transfer conditions in the presence a chiral binaphthyl ammonium catalyst **289**.³³² Conjugate addition was the only reaction that occurred, and the Michael adducts **290** were furnished in excellent yields under a variety of conditions. However, the stereoselectivity and enantioselectivity were sensitive to the reaction conditions, which were optimized, and under these conditions excellent results were obtained for a number of ketones (Scheme 132), the best when *t*-butyl 2-cyano-3-phenylpropanoate (**288**, $\text{R}^1 = \text{Bn}$) was reacted with *t*-butyl ethynyl ketone (**71**, $\text{R}^2 = t\text{Bu}$) and afforded **290** in a total yield of 99% with a *E/Z* ratio of 3.3/1.0 and an ee of 93% and 87% for the *E*- and *Z*-isomer, respectively.³³²

Scheme 132. Catalytic Enantioselective Conjugate Addition of *t*-Butyl 2-Cyanopropanoate Derivatives **288 to Ynone **71** under Phase-Transfer Conditions**

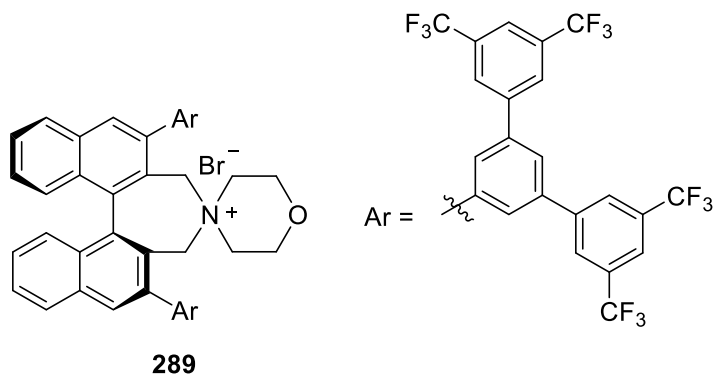
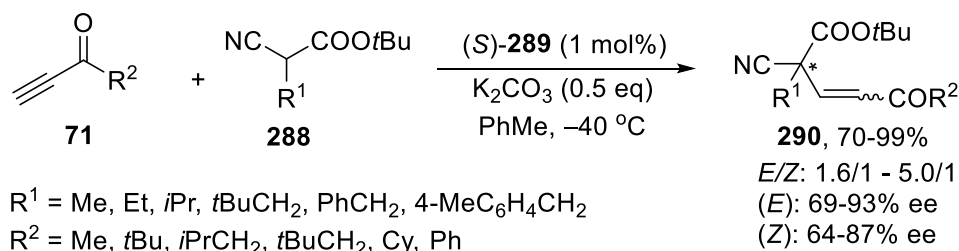

Maruoka and co-workers also studied similar reactions with cyclic β -keto esters **291** for the construction of all-carbon quaternary centres in an enantioselective fashion.³³³ Under the best conditions, the chiral ammonium salt **292** catalyzed the addition of **291** to acetylenic ketones **71**, which afforded Michael adducts **293** in essentially quantitative yields with a moderate *E/Z* selectivity, but in several cases with good enantioselectivity (Scheme 133). Since the *E/Z* isomers are easy to separate by chromatography, the high enantioselectivity, above 90% for some *E* isomers, makes the method a good tool for the preparation of all-carbon quaternary stereocenters.³³³

Scheme 133. Catalytic Enantioselective Conjugate Addition of Cyclic β -Keto Esters **291** to Ynones **71** under Phase-Transfer Conditions

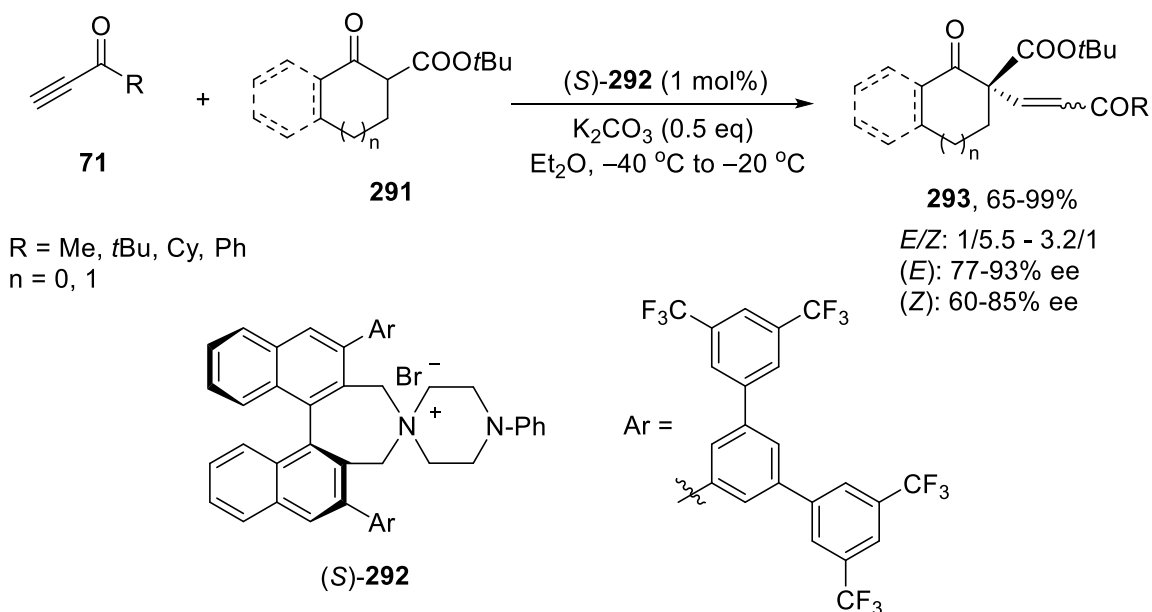

A noteworthy point about the conjugate addition discussed above is that no products due to enolate attack of the β -ketoester carbonyl groups were detected. One conceivable reason is steric protection exerted by the *tert*-butyl group, and this explanation was supported by Li and co-workers.³³⁴ They treated two ethyl 2-oxocycloalkancarboxylates (**294**) first with a base and then with diaryl ketones **71** which are activated for Michael addition, and this paved the way for an efficient synthesis of medium-sized rings **295** through ring expansion (Scheme 134). If the aryl group attached to the carbonyl group in **71** has a chlorine or bromine atom in *ortho* position, a nucleophilic aromatic substitution (S_NAr) takes place and affords fused-ring compound **296**, generally in excellent yield (Scheme 134).³³⁴ The formation of both **295** and **296** is a consequence of carbanion reactions converting allenoate **I** into enolate **IV** via intermediates **II** and **III** (Scheme 134). Analogous secondary reactions were observed by Sydnes and co-workers when they treated mixtures of 1,1-diethoxy-5-hydroxyalk-3-yn-2-ones and ethyl acetate with sodium ethoxide and isolated tetrasubstituted furans in excellent yields.³³⁵

Scheme 134. Conjugate Addition of Cyclic β -Ketoesters **294** to Yrones **71**

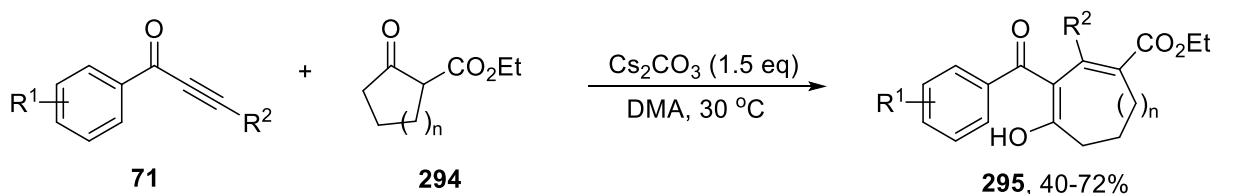

$R^1 = \text{H}, 4\text{-Cl}, 4\text{-Br}, 4\text{-Me}, 4\text{-MeO}, 3,4,5\text{-(MeO)}_3$

$R^2 = \text{Ph}, 4\text{-ClC}_6\text{H}_4, 4\text{-MeC}_6\text{H}_4, 4\text{-MeOC}_6\text{H}_4, 3,4,5\text{-(MeO)}_3\text{C}_6\text{H}_2$

$n = 1, 2$

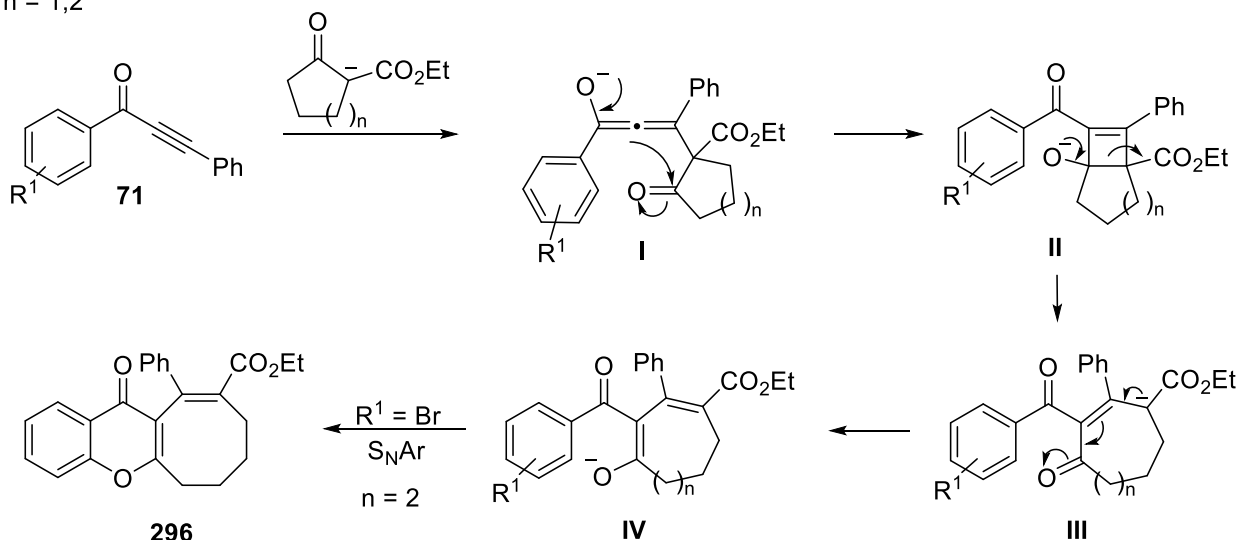

Conjugate addition to α,β -alkynones **71** has also been studied by Bella and Jørgensen, who achieved organocatalytic enantioselective formation of adducts **298** by reacting butyn-2-one and several ethynyl aryl ketones with 1,3-diones **297**.³³⁶ The feasibility of such a transformation was verified by investigating the addition of 2-acetylcyclopentanone in the presence of a *Cinchona* alkaloid or a derivative thereof. The reaction appeared to go quickly to completion and gave the corresponding Michael adduct

298 in excellent yield as an *E/Z* mixture with moderate selectivity. The best results were obtained with [DHQ]₂PHAL as catalyst. For both aromatic and aliphatic alkynones, the addition of the 1,3-diketones was efficient under the best conditions and furnished a mixture of (*E*)- and (*Z*)-enones in high yields with moderate *E* selectivity, but with good to high enantioselectivity (Scheme 135).³³⁶ The moderate *E* preference is seemingly a drawback, but by applying a catalytic amount of tributylphosphine, efficient *Z*-to-*E* isomerization occurred so that (*E*)-isomer of the adducts were isolated in high yields (70-92%) with an enantiomeric excess as an average of the values obtained for the (*Z*) and (*E*) isomers.

Scheme 135. Enantioselective Conjugate Addition of Cyclic 1,3-Diones **297 to Ynones **71****

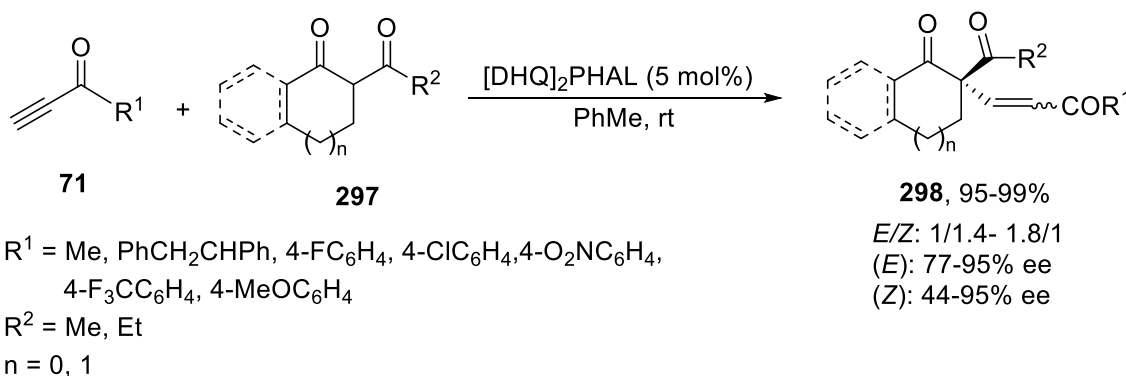

Hu and co-workers used sulfonyl activation to achieve fluoroalkylation of conjugated aryl alkynyl ketones.³³⁷ The reagent was fluorobis(phenylsulfonyl)methane **299** and the base CsOH, and when the reactions were carried out in *N*-methylpyrrolidinone (NMP), the corresponding β -fluoroalkylated α,β -unsaturated enones **300** were formed stereoselectively with *E* configuration and isolated in good to excellent yield when 50% excess of ynone was applied (Scheme 136).³³⁷

Scheme 136. Conjugate Addition of Fluorobis(phenylsulfonyl)methane **299 to Ynones **71****

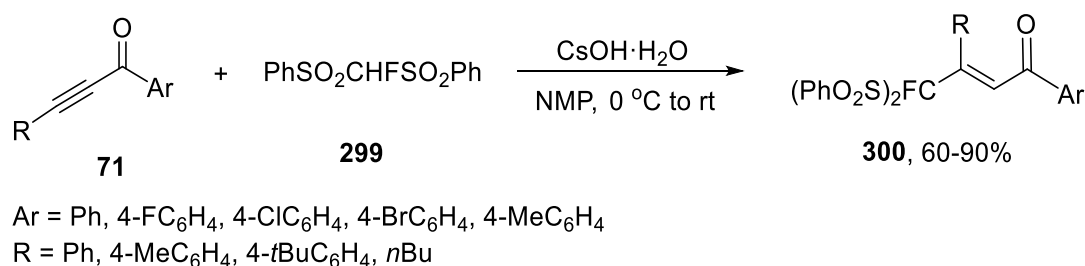

Fluoroalkylation of aryl alkynyl ketones **71** using 2-fluoro-2-(phenylsulfonyl)acetophenone (**301**) was also successful, but the first step, conjugate addition, was consistently followed by migration of the benzoyl group of the acetophenone, affording α -benzoylated- β -fluoroalkylated α,β -unsaturated enones **302** as the final products.³³⁷ The yields were generally quite good, but unlike fluoroalkylation

with **299**, the reaction showed no stereochemical preference (Scheme 137). This lack of specificity is conceivably due to intermediate formation of anions **I** and **II** and finally allylic anion **III**.

Scheme 137. Conjugate Addition of 2-Fluoro-2-(phenyl-sulfonyl)acetophenone (301) to Ynone 71

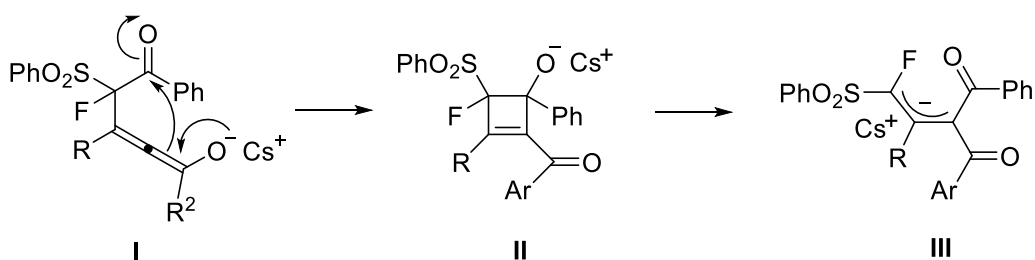
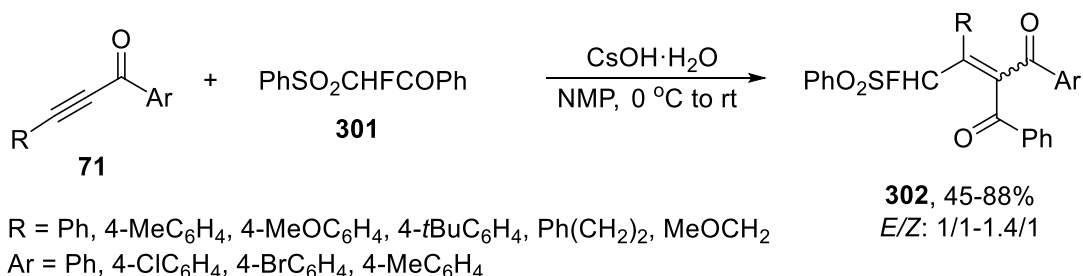

An intramolecular enolate addition to a conjugated ynone is also the key step in the successful synthesis of (-)- α -kainic acid by Jung and co-workers.⁵⁶ When phenylsulfone **54** was treated with cesium carbonate, the carbanion formed between the amide moiety and the phenylsulfonyl group attacked the ynone in a Michael fashion and furnished the tricyclic lactam **303** in high yield as a single diastereomer (Scheme 138). A low concentration of the reaction solution and a short reaction time were key factors for the high yield.

Scheme 138. Intramolecular Cyclization of Ynone 54

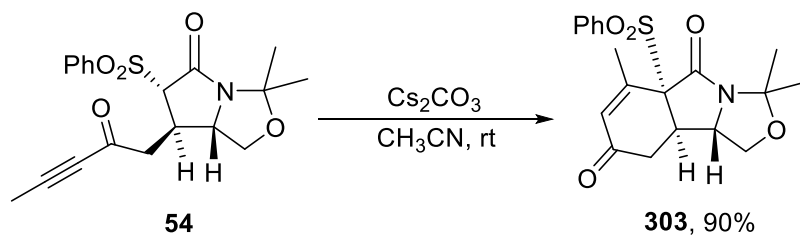

Electrochemical techniques have also been applied to generate various carbanions used in Michael additions to ynone. Electrolysis of pure nitroalkanes under galvanostatic control in a divided cell equipped with Pt electrodes affords the corresponding carbanions, which have been reacted with several 3-(2-aminophenyl)-1-arylprop-2-yn-1-ones (**200**).³³⁸ Conjugate addition of the carbanion takes place, but the keto moiety of the resulting enones react subsequently in an intramolecular fashion with the amino group and form 4-nitroalkylquinolines **304** in up to 93% yield (Scheme 139). Other reactions

show that diethyl malonate and 2-ethoxycarbonylcyclopentanone react in a similar fashion.³³⁸

Scheme 139. Heterocyclization of Yrones **200** Promoted by Electrogenerated Carbanions

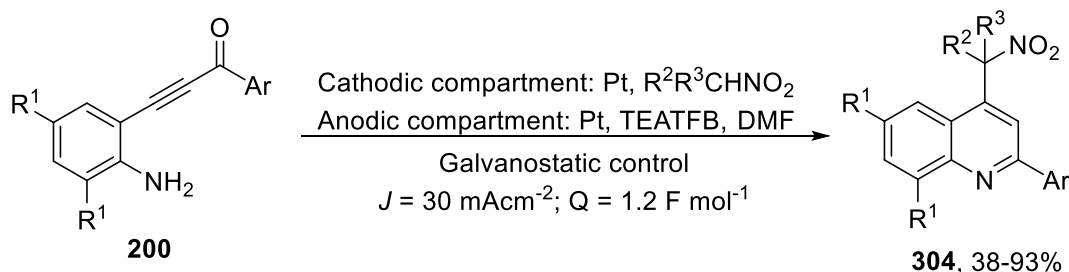

Ar = 2-MeOC₆H₄, 4-MeOC₆H₄, 3,5-Me₂C₆H₃, 1-naphthyl

R¹ = H, F; R² = H, Me; R³ = H, *n*Pr, Me

TEATFB = tetraethylammonium tetrafluoroborate

It should also be mentioned that the reactivity of ethyl acetoacetate (EAA) toward ynones has been utilized to prepare a pyridine scaffold bearing an alkyne moiety. Treatment of 1-phenyl-5-triisopropylsilylpenta-2,4-diyne-1-one (**305**) with a mixture of EAA and ammonium acetate resulted in a regioselective Michael addition followed by condensation and formation of pyridine **306** in 78% yield (Scheme 140).³³⁹

Scheme 140. Pyridine **306** Formation by a Tandem Conjugate Addition of EAA-Amonium Acetate Condensation to Diynone **305**

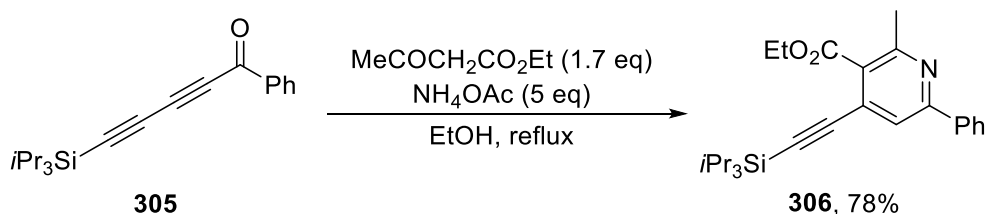

In conclusion, compounds containing 1,3-dicarbonyl and other electron-withdrawing moieties undergo efficient Michael addition to conjugated ynones when treated with a weak base, most frequently a carbonate. Most reactions are intermolecular, and the yields are often excellent. By adding a chiral ligand, asymmetric induction above 90% ee has been achieved.

3.1.2.5. Enols and Other Neutral Nucleophiles. The reactivity of enols and neutral nucleophiles is generally lower than that of charged analogues so activation by addition of an electrophile such as a Lewis acid (LA) or a LA complex is generally required to facilitate the reaction. Gold(I) complexes have appeared to be particularly attractive because as soft Lewis acids they coordinate selectively with certain structural motifs, including alkynes,³²⁷ which facilitate regioselective bond formation.

γ -Alkenyl butenolides **308-310** have been synthesized by conjugate addition of β,γ -butenolides **307** to a large number of ynones **71** by Feng and co-workers.³⁴⁰ The outcome depends on the substituent attached to the β carbon of the triple bond. When the reaction was carried out with terminal alkynones (**71**, $R^1 = H$) in the presence of a chiral catalyst ($L = RaPr_2$), one of several N,N' -dioxide scandium(III) complexes, Michael adducts **308** were isolated in high to excellent yield (up to 98%) with high E/Z ratios (up to >19/1) and very high enantioselectivity (up to 98% ee) (Scheme 141). Application to internal alkynones, however, gave mixed results. When R^1 was electron donating group, conjugate addition did not occur, but by introducing an electron-withdrawing group such as the ethoxycarbonyl moiety, γ -alkenyl butenolides **309** were formed in excellent yield with high stereoselectivity and excellent enantioselectivity using $L = PiPr_2$. An elegant application of these findings is the construction of the C-4 position of the bioactive compound OH-3984 (**310**) (Scheme 141). The reaction does not involve an enolate, but rather a chiral enol complex formed by initial interaction between the carbonyl group and the scandium ion.³⁴⁰

Scheme 141. Enantioselective Conjugate Addition of Butenolides 307 to Ynones 71 Catalyzed by Chiral Scandium Complexes

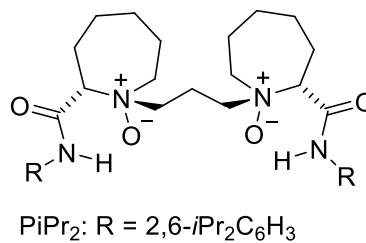
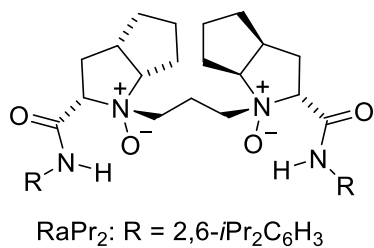
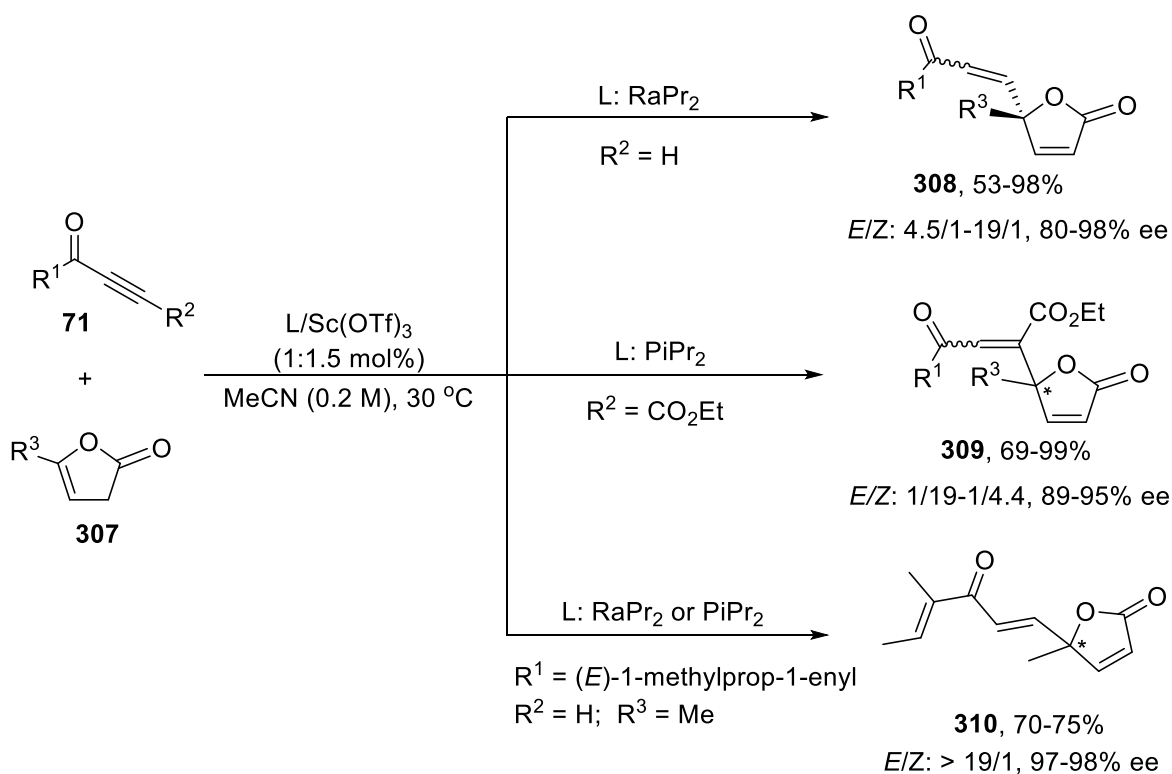

3.1.3. Heteronucleophiles

3.1.3.1. Nitrogen Nucleophiles. Nitrogen is the heteronucleophilic element used most extensively in Michael additions to ynones. Most of these nucleophiles are amines and the final outcome depends on the structure of both the substrate and the nucleophile. Thus, the substrate may contain a nucleophilic moiety that reacts with the primary product because it is situated in a favourable position enabling subsequent intramolecular attack that leads to cyclization. As for the nucleophile, it may have several nucleophilic centers and undergoes a domino transformation, first a Michael addition and then a condensation reaction with the keto function. In the following three different main scenarios are presented.

3.1.3.1.1. Intramolecular Hydroamination. A few stable α,β -unsaturated ynones with an amino group at either α' or β' position have been reported to undergo conjugate addition when activated by an electrophile and form five- and six-membered heterocycles, respectively. Gouault and co-workers used this approach to synthesize a selection of Boc- and Cbz-protected pyrrolin-4-one derivatives (**311**) with moderate to total stereocontrol from α' -aminoynones **100** easily accessible from α -amino acids.⁹⁶ Their work was based on a report by Overhand and Hecht who used a stoichiometric amount of mercury acetate to achieve the same ring closure.³⁴¹ By switching to gold(I) chloride the transformation became much more efficient and proceeded in almost quantitative yield even with a catalytic loading below 10 mol%. Under these conditions the reaction appeared to be quite versatile and tolerated very well structural variations in the substituents on the triple bond (R^1), in the protecting group (PG), and in R^2 , as evidenced by the consistently high yield of the corresponding pyrrolin-4-ones **311** (Scheme 142).⁹⁶

Scheme 142. Au(I)-Catalyzed Intramolecular Hydroamination of α -Aminoynones **100**

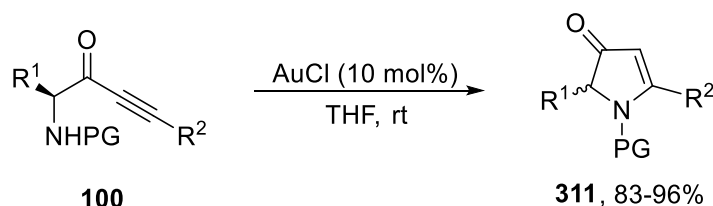

$R^1 = \text{H, Me, } i\text{Pr, sBu, Bn, (indol-3-yl)methyl}$
 $R^2 = \text{H, } n\text{Pr, Ph, 4-MeOC}_6\text{H}_4$
 PG = Boc, Cbz

Epimerization was a problem when AuCl was the catalyst,⁹⁶ and studies of the catalyst's influence was therefore carried out using the *S* enantiomer (ee>99%) of a Boc-protected α -aminoynone from valine (**100**, $R^1 = \text{Ph}$ and $R^2 = i\text{Pr}$) as substrate. A number of catalytic systems based on gold(I) and gold(III) were tested and optimized, and Au₂O₃, in the absence of base, emerged as the catalyst of choice, giving the corresponding pyrrolin-4-one (**311**, $R^1 = \text{Ph}$ and $R^2 = i\text{Pr}$) in 95% yield with complete retention of configuration.⁹⁶ When similar Boc-protected α' -aminoynones were reacted under these conditions, equally excellent results were obtained in most cases (Scheme 143).⁹⁶

However, when Cbz protection was applied instead of Boc, considerable epimerization occurred and lowered the ee to 50%.

Scheme 143. Au(III)-Catalyzed Intramolecular Hydroamination of α' -Aminoynones **100**

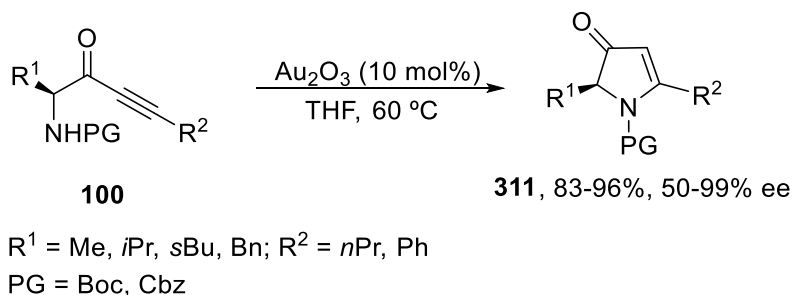

Conversion of α' -aminoynones **100** (PG = Boc) to pyrrolin-4-ones **311** has also been achieved by Lamaty and co-workers who used iodine in the presence of sodium bicarbonate to activate the triple bond.³⁴² Two procedures were used, both of which exhibit some unattractive features. The first method used microwave activation and PEG-3400 as reaction medium, which was seemingly attractive because the reaction was fast (minutes) and the conversion high (100% in most cases), but the work-up was tedious and a lot of the product was lost. Common solvents were therefore used instead, and this gave 3-iodopyrrolin-4-ones (**312**) in good to excellent yields under the best conditions (Scheme 144). Unfortunately, some epimerization occurred, but in the best cases ee better than 90% was obtained.

Scheme 144. Iodine-Promoted Intramolecular Hydroamination of α' -Aminoynones **100**

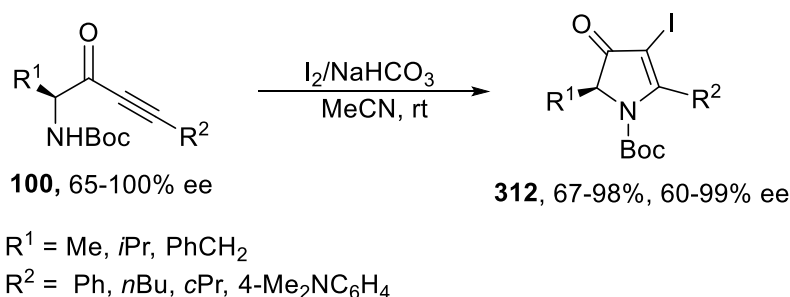

Lamaty's overall approach gave even better results when Boc-protected α' -aminoynones **100** (PG = Boc) were activated by a $\text{PtCl}_2/\text{K}_2\text{CO}_3$ instead of iodine.³⁴³ With this catalytic system PEG-3400 was a superb reaction medium when combined with microwave irradiation. All substrates furnished **311** in excellent yield and purity, but with respect to epimerization the picture is more mixed; for hindered substrates the enantiomeric ratio was almost preserved, for less hindered a considerable loss was observed in the worst cases (Scheme 145).³⁴³

Scheme 145. Pt-Catalyzed Hydroamination of Boc-Protected α' -Aminoynones **100 under Microwave Irradiation in PEG**

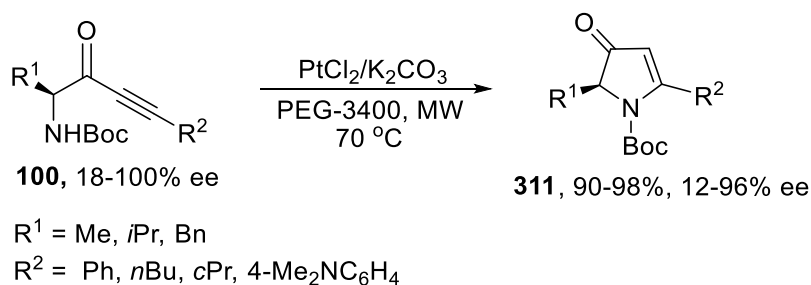

A different approach to the synthesis of pyrrolin-4-ones was recently published by Pale, Blanc, and co-workers.³⁴⁴ By exploiting the π -activation of gold cations and their dual π and σ Lewis acidities, a number of pyrrolin-4-ones were synthesized from readily available 1-(*N*-sulfonylazetidyn-2-yl)alk-2-yn-1-ones **313** via gold(I)-catalyzed cyclization followed by nucleophilic substitution induced by nucleophiles added in significant excess. The Gagosz's catalyst [triphenylphosphine gold(I) bis(trifluoromethanesulfonyl)imidate³⁴⁵] was applied first, but the reaction was slow and two products were formed, the expected 2,5-disubstituted *N*-sulfonylpyrrolin-4-one **311** (PG = ArSO₂) and a dimeric pyrrolinone/pyrrole compound. Switching to the JohnPhos ligand was very productive; the reaction time dropped, the yield passed 80%, and the amount of dimer became close to negligible. A number of nucleophiles worked very well, and among the best were methanol which was selected when the scope of the transformation was examined with JohnPhosAuNTf₂ (**314**). The results are summarized in Scheme 146. The tosyl group turned out to function better than the 4-methoxybenzenesulfonyl (Mbs) and 4-nitrobenzenesulfonyl (Ns) protecting groups and certain substituents in propargylic position improved the yield. It is also noteworthy that the reaction can be carried out in the presence of an electrophilic halogen source, such as *N*-iodosuccinimide (NIS), which paves the way for halodeauration instead of protodeauration and formation of *N*-tosyl-3-halopyrrolin-4-ones **312** (Scheme 146).³⁴⁴

Scheme 146. Au(I)-Catalyzed Transformation of Azetidinyones 313 into Pyrrolinones 311 and 312

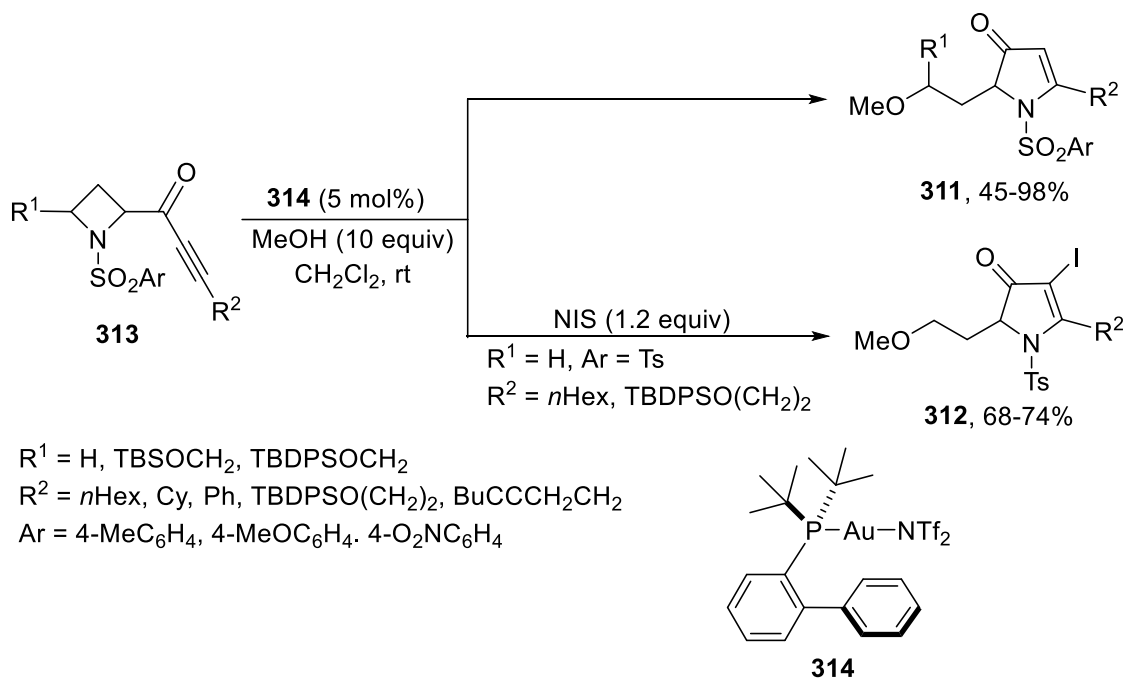

Gouault and co-workers have also carried out intramolecular Michael addition with β' -amino- α,β -unsaturated yrones (**71**) and prepared cyclic, six-membered enaminones in almost quantitative yields in the best cases. Attempts to achieve cyclization by activation of the triple bond with electrophilic halogen alone (iodine and *N*-halosuccinimide) failed, but when combined with a metal cocatalyst, the reaction succeeded. Screening revealed that Au_2O_3 , the catalyst of choice when the corresponding α' -amino- α,β -unsaturated yrones were cyclized, barely gave any product, but when a mixture of PPh_2AuCl and AgSbF_6 was used, the reaction proceeded smoothly with *N*-iodosuccinimide (NIS) or *N*-bromosuccinimide (NBS) as a halonium source (the chloro analogue did not work).³⁴⁶ Under optimized conditions a series of 5-halo-2,3-dihydropyridone (**316**) were obtained in moderate to excellent yield (Scheme 147). The product formation involves ammonium intermediate **I** which, however, can also suffer protodeauration to give **317**, a reaction that lowers the yield of **316**.³⁴⁶

Scheme 147. Au(I)-Catalyzed Halocyclization of Aminoyrones **315** to 5-Halopyridones **316**

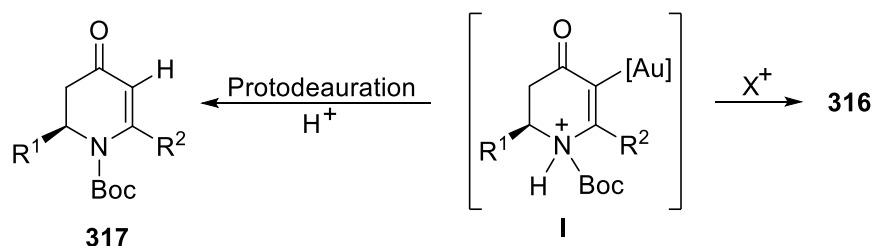
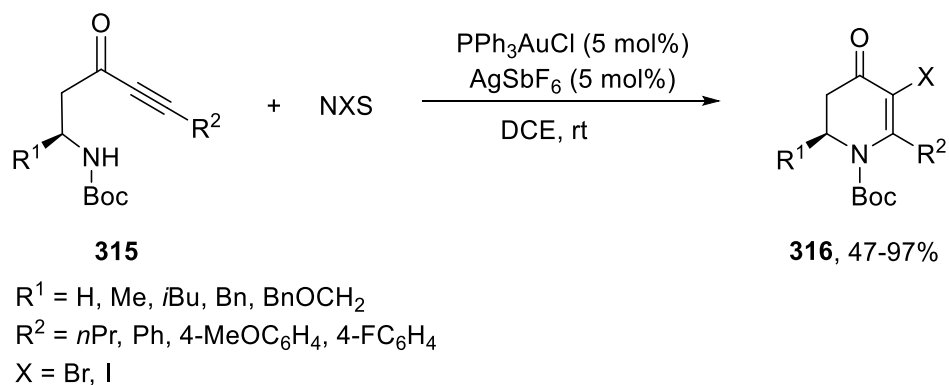

Intramolecular conjugate addition was seemingly also achieved by Turunen, Georg and co-workers when a series of Boc-protected β' -amino- α,β -unsaturated ynones **318** were deprotected (HCl/dioxane or TMSI/DCM) and subsequently cyclized by using MeOH/K₂CO₃. Following this protocol, bicyclic enaminones **319** were prepared and generally isolated in excellent yield with high stereoselectivity (Table 1).^{89,90,95} However, mechanistic studies proved that conjugate addition did not take place; instead, addition of halide (to give **320**) and methanol (affording **321**) in a Michael fashion took place before the amine group attacked through intermediate **I** (Scheme 148).^{89,95}

Table 1. Synthesis of Six-Membered Cyclic Enaminones 319 from Yrones 318

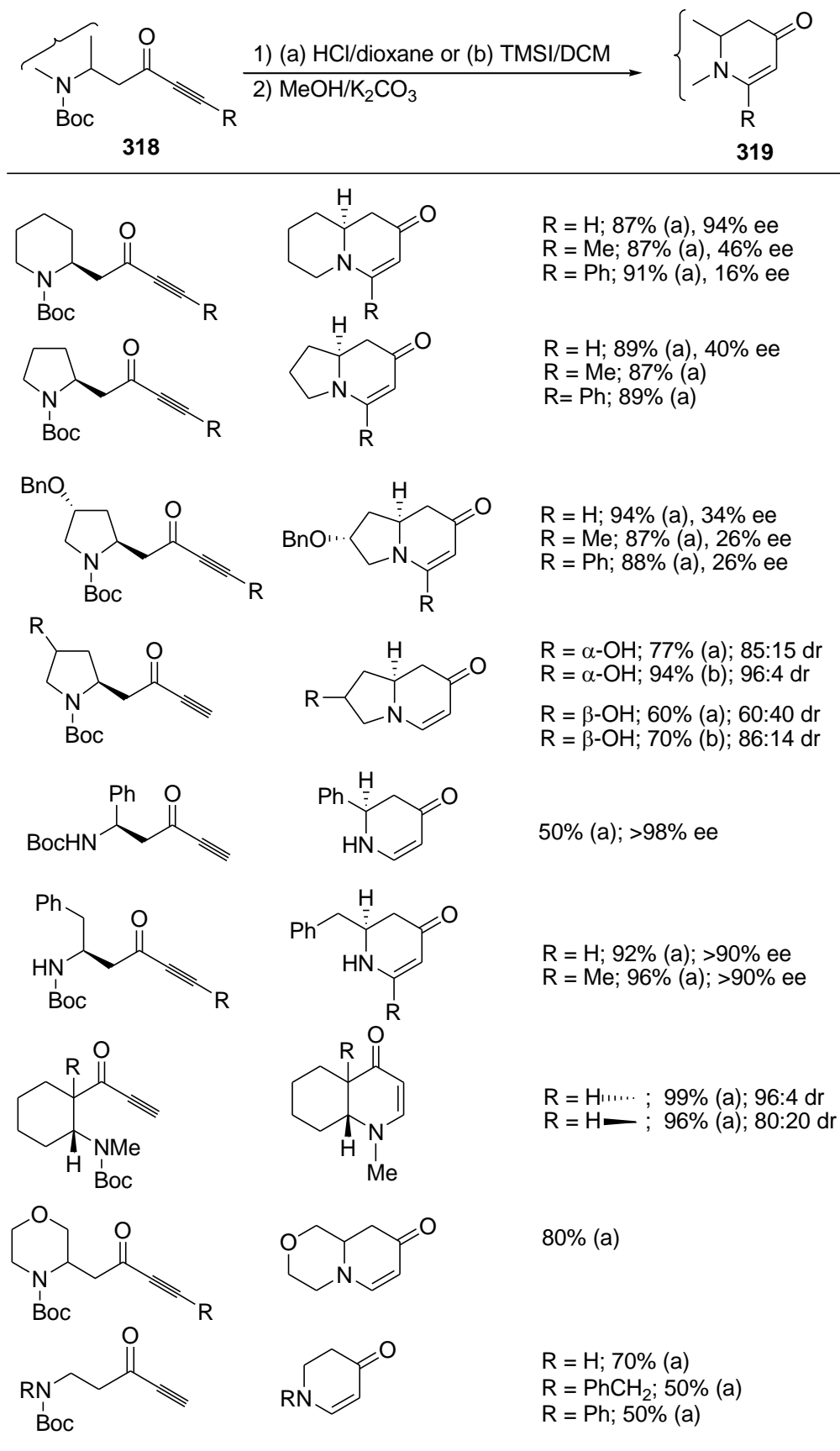

Scheme 148. A Conceivable Pathway for Six-Membered Cyclic Enaminones Formation

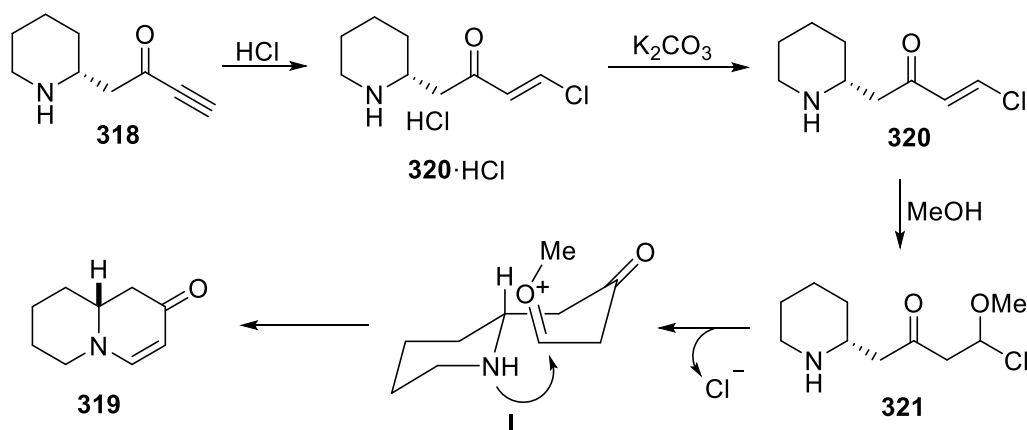

Epimerization is a challenge when **318** underwent intramolecular cyclization and form enaminones under the conditions given in Table 1. Georg and co-workers therefore carried out further investigations to milder conditions that improved the yield and lowered the epimerization.⁹⁰ Such conditions were indeed found (NaI (3 eq)/HCOOH), and when applied to **318**, **319** was obtained in good yield, in several cases with a low degree of epimerization.⁹⁰

The successful preparation of the 6-membered enaminones led to exploration of the possibility to construct 5- and 7-membered rings as well.⁹⁰ The results were mixed, but consistent in the sense that only the larger-ring compounds **323** were formed. The yields from **322** were medium to good under two sets of conditions (Methods a and b, Table 2).⁹⁰ The lack of formation of the corresponding 5-membered rings is in accordance with the hypothesis that the reaction requires an *endo-trig* mode of cyclization which is disfavoured for five-membered transition states according to Baldwin's rules.^{347,348} However, 5-membered rings were formed under other reaction conditions (Section 3.2.4).

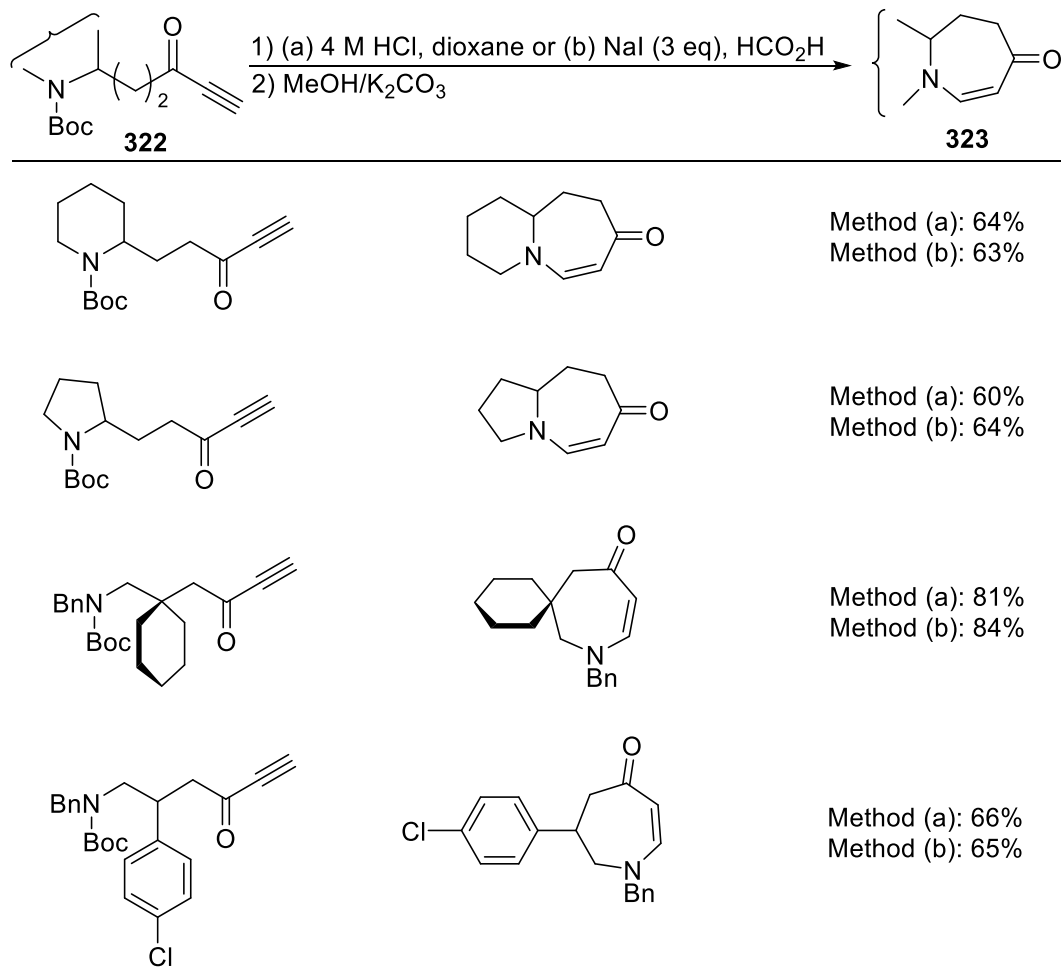
Table 2. Synthesis of Seven-Membered Cyclic Enaminones 323

A reaction overall similar to the cyclization depicted in Scheme 148, takes place when a series of 1-(2-pyridyl)-3-butyn-2-one derivatives (**324**), a pyrazine analogue, and an isoquinoline analogue are treated with catalytic quantities of silver nitrate and converted to a variety of 2H-quinolizin-2-ones (**325**).²⁹⁵ Taylor, Unsworth and co-workers prepared a dozen of such ketones under optimum conditions in up to quantitative yield with just 2 mol% Ag⁺ at room temperature (Scheme 149). In all cases except two, the substituent attached to C-4 is an aryl group. One of the exceptions is the trimethylsilyl group which makes a one-pot desilylation-cyclization sequence available for the preparation of unsubstituted quinolizinone (**73**). The reaction is robust and believed to involve cationic complex **I** and bicycle **II** as key intermediates. An application of the reaction in natural-product synthesis is shown in Scheme 150.²⁹⁵ Starting from compound **324** the cyclization to **325** followed by catalytic hydrogenation afforded **326**, which without isolation was oxidized to **327** and reduced to give (±)-lasubine II.

Scheme 149. Ag-Catalyzed Cyclization of β'-Amino-α,β-unsaturated Ynones 324 to Pyridones 325

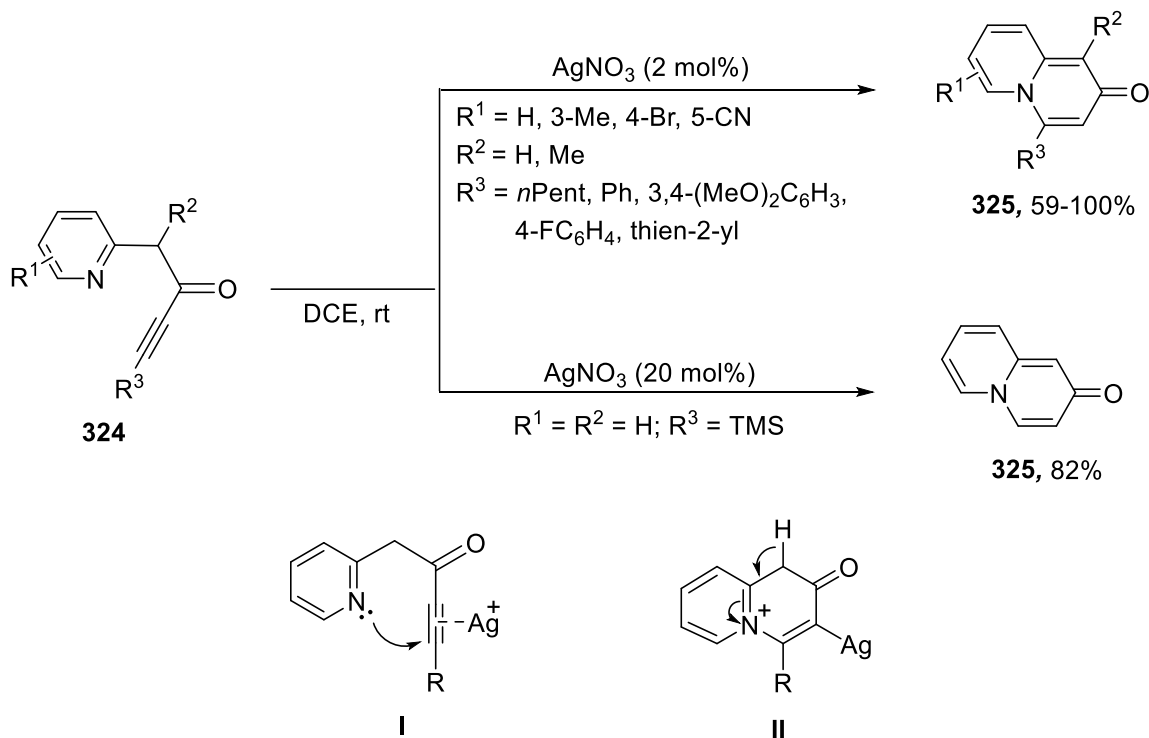

Scheme 150. A Five-step Total Synthesis of (\pm)-Lasubine II (**328**)

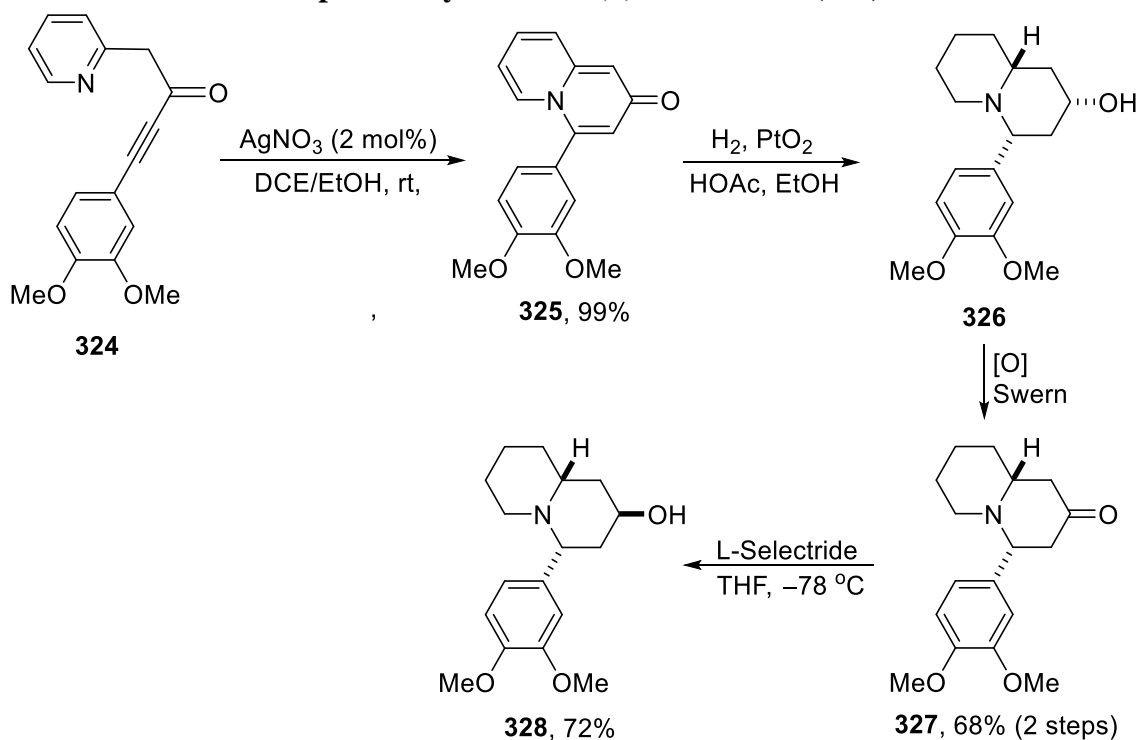

A closely related Ag(I)-catalyzed hydroamination was reported by Fuwa and co-workers in connection with a study of an ynone-based strategy for the synthesis of dihydropyrones (Section 3.1.3.2.1). When β' -Cbz-protected amino ynone **329** was exposed to AgOTf, silver complexation to the triple bond activated the β carbon so that the somewhat deactivated nitrogen group would attack and furnish *N*-Cbz-protected

dihydropyridine-4-one **330** which was isolated in 50% yield (Scheme 151).¹⁷⁰ The use of 2,6-di(*tert*-butyl)pyridine (DTBP) as an additive is worth noting.

Scheme 151. Ag-Catalyzed Intramolecular Hydroamination of Ynone 329

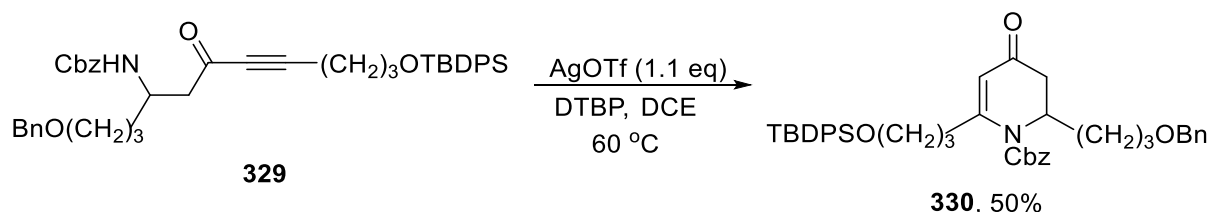

To conclude, intramolecular hydroamination of *N*-protected α' - and β' -amino- α,β -ynones, leading to high yields of *N*-protected pyrrolin-4-ones and 2,3-dihydropyrid-4-ones, respectively, can be catalyzed by a variety of catalysts, mainly metals [Au(I), Au(III), Ag(I) and Pt(II)], iodine, and hydrochloric acid. Chiral substrates undergo the reaction almost without racemization. Some α' -(pyrid-2-yl)- α,β -ynones react similarly under Ag(I) catalysis giving quinolizin-2-ones in good yields.

3.1.3.1.2. Intermolecular Hydroamination. This conjugate addition to ynones is a robust synthetic approach to enaminones. Ammonia and a large variety of primary and secondary amines have been reacted with a range of ynones and furnished enaminones with a considerable structural variation. In general, the products are stable and formed in very good yields, except when (a) tertiary amines are applied,^{79,349,350} (b) the substrate contains a nucleophile that can attack the primary product (enaminone),^{351,352} and (c) primary amines are applied and the resulting products contain an electrophilic center that can react with the nitrogen in the enaminone moiety.^{152,353} Furthermore, the reaction is stereoselective in most cases. As a general rule, ammonia and primary amines form the *Z* isomer only, because of intramolecular hydrogen bonding, whereas secondary amines give the *E* isomer due to the repulsion caused by steric interactions provided when the ynone β substituent is not sterically demanding.³⁵⁴

The reactions with ammonia and primary and secondary amines have been carried out under a variety of conditions. Some reactions have been performed at room temperature,^{102,350,355,356} but higher temperatures are more common,^{141,184,357-360} even as high as 120 °C^{150,361} and 140 °C,³⁶² and typically with 1.0-1.1 molar eq of the amine and no additional reagent(s), although the amine has also been used as solvent.^{14,174,244,353,354} A variety of solvents have been applied, including alcohols^{149,350,358} and non-protic solvents like PhMe,^{182,150} MeCN,³⁶³ DCM, THF,^{139,141} DMSO,^{364,365} 1,4-dioxane,^{151,366} and DMF.³⁶⁷ The reaction time is usually short, but when anilines with one or several electron-withdrawing groups attached to the ring are used, even days have been required to obtain some product.³⁶⁸

Many examples involve aniline derivatives, which contain an additional *ortho* substituent that allows subsequent cyclization and preparation of heterocycles, e.g. indoles,³⁶⁹ pyrroles,³⁵⁸ imidazo[1,2-*a*]pyridines,³⁷⁰ and quinolines.³⁵³

It is noteworthy that the enaminones do not undergo a subsequent Michael addition under the conditions applied to perform hydroamination of the ynones. This was clearly demonstrated by Marinelli and co-workers who used morpholine and pyrrolidine as solvents, in reactions with 3-(2-amino-5-methylpyridin-3-yl)-1-(4-acetyl-phenyl)prop-2-yn-1-one (**331**).²⁴⁴ The resulting enaminones **332** did not suffer conjugate addition, but were attacked intramolecularly by the NH₂ group and afforded [1,8]naphthyridines **333** (Scheme 152).²⁴⁴ Amines, therefore, behave differently from thiolates when exposed to ynones (Section 3.1.3.3.3).

Scheme 152. Intermolecular Hydroamination of Ynone 331 with Morpholine and Pyrrolidine

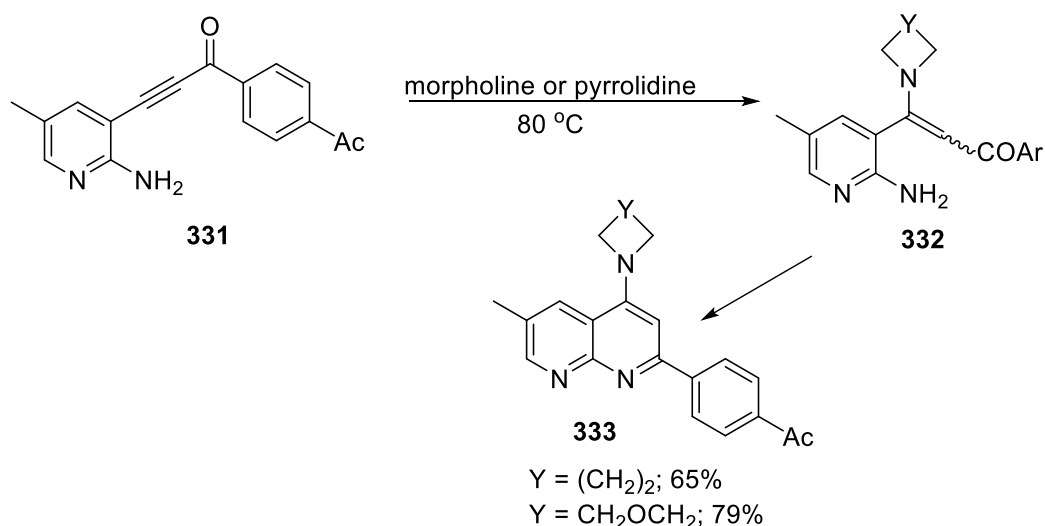

Intermolecular hydroamination is the crucial step in the synthesis of number of heterocycles found in alkaloids and pharmaceuticals products.^{141,182,353,360} One group of such compounds is 3-acylquinolines **335**, which Li and co-workers prepared by an iron(III)-catalyzed cascade reaction of ynones **71** with *o*-aminoaryl aldehydes and ketones and *o*-aminobenzyl alcohols **334** in the presence of air.³⁵³ The best results were obtained with the aldehydes which have the most reactive electrophilic center available for attack by the intermediate allenoxo moiety formed during the conjugate addition. The results are summarized in Scheme 153.

Scheme 153. Synthesis of 3-Acylquinolines 335 by Iron-Catalyzed Cascade Michael Addition-Cyclization of Anilines 334 with Ynones 71

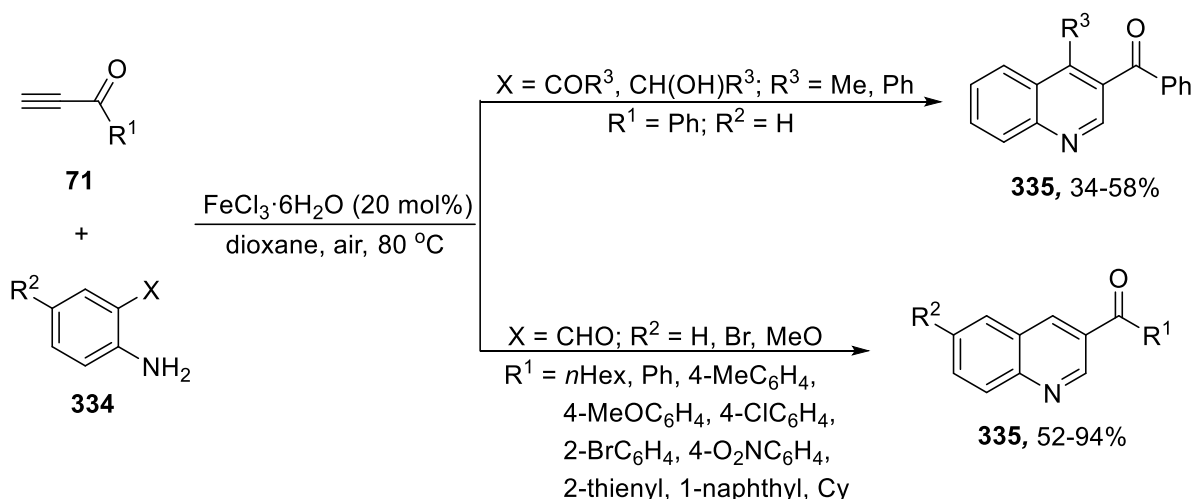

Another example is the tetrahydro- β -carboline derivative **339**,^{182,360} which can be synthesized in a one-pot, three-step reaction sequence involving an intermolecular hydroamination of ynone **336** with tryptamine giving enaminone **337**, which suffers acylation-annulation to give intermediate **338**. This iminium salt then undergoes a Pictet-Spengler reaction to yield the final product **339** (Scheme 154).³⁶⁰

Scheme 154. A Three-Step Synthesis of a Tetrahydro- β -carboline Derivative **339**

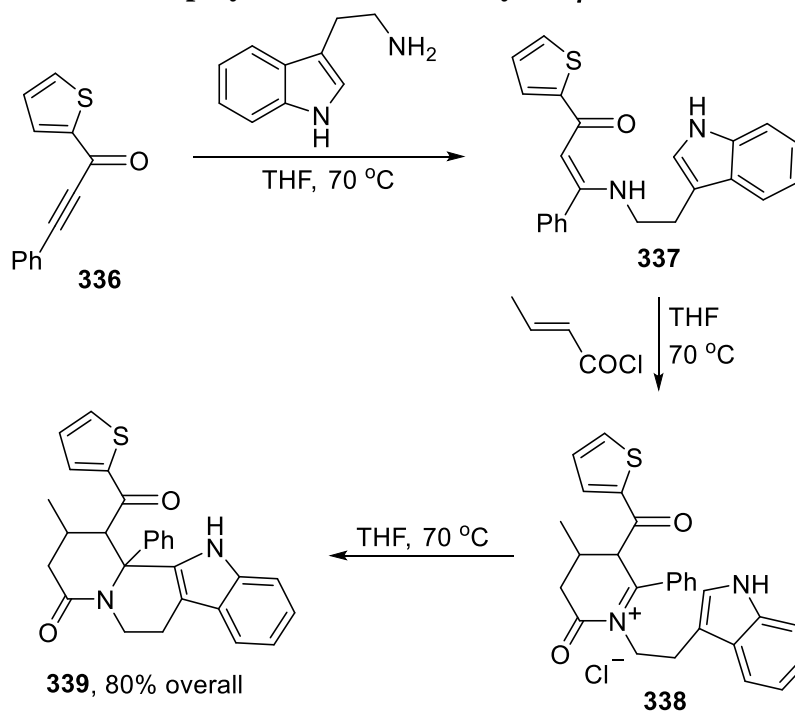

Hydroxylated amines give the expected enaminones in good to excellent yields when performed under mild conditions (EtOH, rt)^{349,350,355} and in refluxing dioxane.³⁶⁶ The reaction is stereoselective and give the *Z* isomers exclusively when primary amines are used, but subsequent cyclization via hemiacetal formation followed by an elimination has not been reported. However, the stability at elevated temperature may be limited. Thus, when derivatives of 1,1,1-trifluoro-4-(2-hydroxy-ethylamino)-4-phenylbut-3-en-2-one

are refluxed in ethanol, fragmentation occurs and acetophenone and a trifluoroacetamide are formed.³⁵⁵ And when a sterically hindered ethanamine like pseudoephedrine is reacted with some 3-aryl-1-(3,4,5-trimethoxyphenyl)prop-2-en-1-one derivatives in refluxing dioxane that is not absolutely dry, decomposition takes place.³⁶⁶

Intermolecular hydroamination of conjugated ynones followed by cyclization has been applied by Langer and co-workers to synthesize aminoquinolones.¹⁵² The substrates were four 2-chloro-5-nitrophenyl 1-alkynyl ketones **150**, which suffered Michael addition and formation of enaminones **340** when treated with primary amines at elevated temperature. Subsequent intramolecular nucleophilic substitution at the chlorine-substituted carbon gave 6-nitro-4-quinolones **341** in up to 90% yield (Scheme 155).¹⁵² Nucleophilic attack is facilitated by the remaining substituents attached to the ring.

Scheme 155. Hydroamination of 2-Chloro-5-nitrophenyl 1-Alkynyl Ketones **150 with Primary Amines**

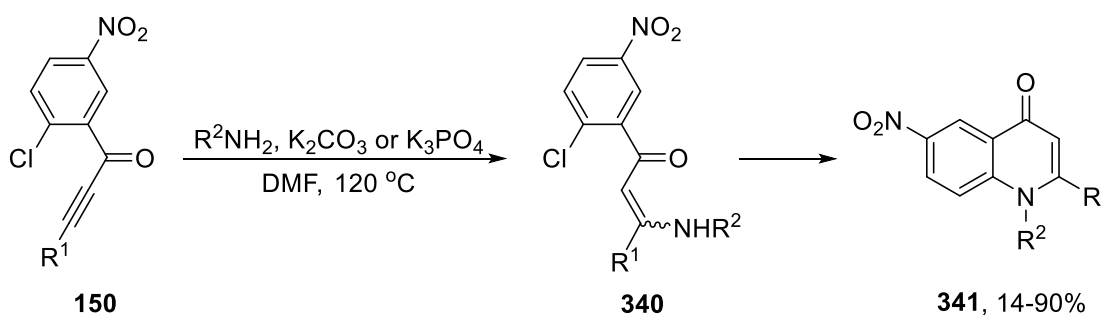

R¹ = *n*Bu, *n*Pent, Ph, 4-MeC₆H₄,

R² = *n*Pr, *i*Pr, *n*Pent, *n*Hex, *n*Hept, Cy, Ph, 3-BrC₆H₄, 3-MeOC₆H₄, 4-MeOC₆H₄, 3,5-Me₂C₆H₃,
2,4,6-Me₃C₆H₂, Ph(CH₂)₂, 4-MeOC₆H₄CH₂, 3,4-(MeO)₂C₆H₃(CH₂)₂, Ph(CH₂)₄, Ph(Me)CH,
3,5-(MeO)₂C₆H₃, 4-*t*BuPh

As pointed out, conjugate addition of primary and secondary amines to ynones is generally stereoselective, but a few exceptions have been observed. A detailed study of the reaction between but-3-yn-2-one and aniline has shown that the stereochemistry of the resulting enaminone can be predominantly *E* or *Z*, depending on the conditions prevailing during these operations. However, upon storage isomerization occurs and an *E/Z* ratio of 3:97 is eventually reached.³⁵⁶ The consequences are even more profound when 2-(2-aminophenyl)ethynyl 4-chlorophenyl ketone (**200**) is reacted with cyclohexylamine: at 80 °C, the corresponding *Z*-enaminone **342** is obtained in 75% yield, but when the temperature is increased to 110 °C (refluxing toluene), the only product isolated is 2-(4-chlorophenyl)-4-cyclohexylaminoquinoline (**343**), formed from *E*-enaminone **342** by imine formation (Scheme 156).³⁶³

Scheme 156. Hydroamination of Ynone **200 with Cyclohexylamine**

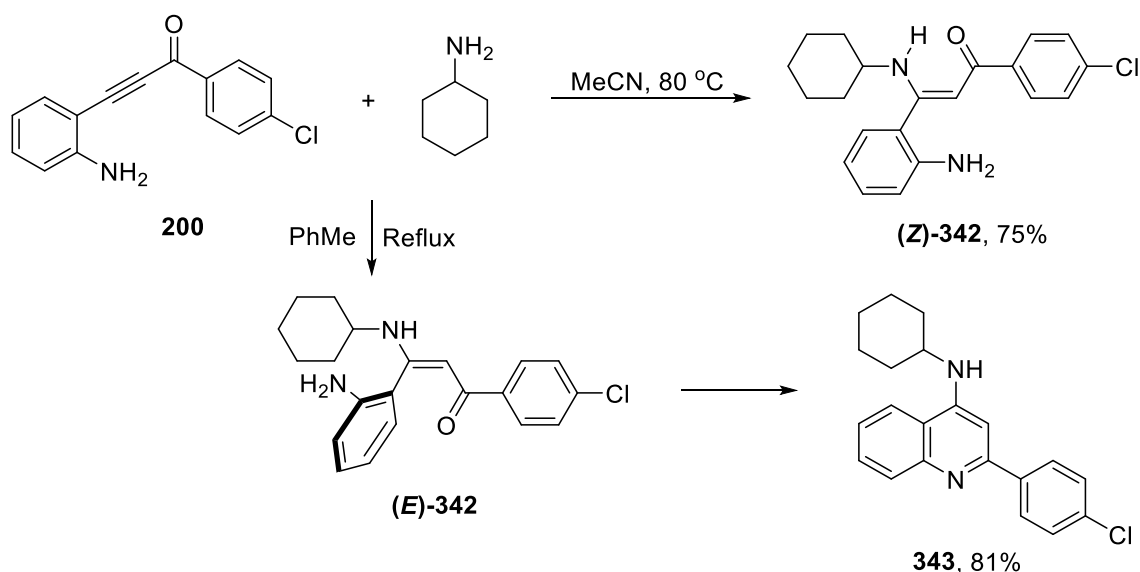

Other nitrogen nucleophiles than amines can undergo Michael addition to conjugated ynones and furnish enaminones. *N*-Arylformamides **344** constitute a prominent group of such compounds. When mixtures of ynones **71** and **344** in DMF are treated with potassium carbonate, *Z*-enaminones **345** are obtained in excellent yields (Scheme 157).³⁶⁷ The deformylation can conceivably occur before or after the nucleophilic attack, but since the formyl group survives in the analogous reaction with less reactive acetylenic sulfones, it is envisaged that the formylated enaminone is hydrolyzed in a separate, but fast transformation after the Michael addition is complete. Enaminones **345** were further transformed into 3-acylindoles under $\text{Cu}(\text{OAc})_2$ catalysis.

Scheme 157. Michael Addition of *N*-Arylformamides **344** to Ynones **71**

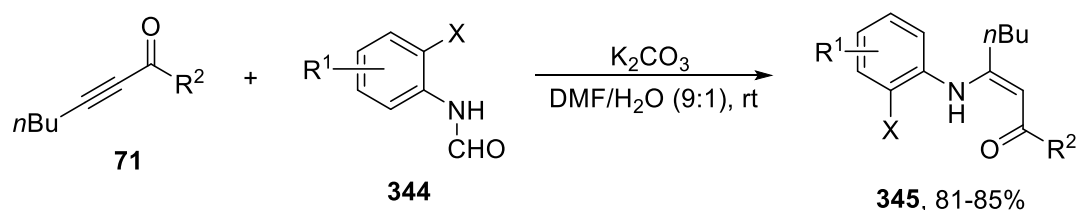

$\text{R}^1 = \text{H}, 4\text{-Me}, 4,6\text{-Me}_2, 4\text{-MeO}_2\text{C}, 4\text{-NC}, 4\text{-Cl}, 4\text{-I}, 4\text{-NH}_2, 4\text{-O}_2\text{N}, 3\text{-O}_2\text{N}$

$\text{R}^2 = n\text{Pr}, \text{Ph}$

$\text{X} = \text{Cl}, \text{Br}, \text{I}$

Another good nucleophilic entity is 3,4-dihydroisoquinoline (**346**), a readily available imine. By exposing **346** to ynones **71** in a somewhat unusual solvent mixture, brine and toluene, Cui and co-workers obtained enaminones **347** in up to excellent yield (Scheme 158).³⁶⁸ The reaction gave the *Z* isomers exclusively due to intramolecular hydrogen bonding. It is also noteworthy that when the isoquinoline had an electron-withdrawing

substituent, no reaction occurred. An aza-Michael/hydrolysis cascade reaction sequence via intermediates **I-III** has been proposed for the transformation.³⁶⁸

Scheme 158. Reaction of Yrones **71** with 3,4-Dihydroisoquinolines **346**

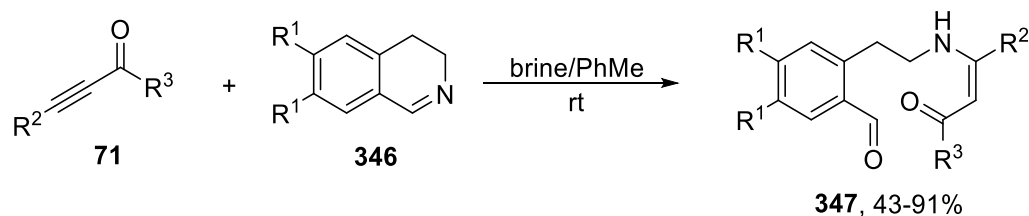

$R^1 = \text{H, MeO}$; $R^2 = n\text{Bu, } n\text{Hex}$

$R^3 = \text{Et}_2\text{CH, 2-furyl, Ph, 4-MeC}_6\text{H}_4, 3\text{-MeOC}_6\text{H}_4, 4\text{-MeOC}_6\text{H}_4, 4\text{-ClC}_6\text{H}_4, 3,4\text{-Cl}_2\text{C}_6\text{H}_3, 2\text{-BrC}_6\text{H}_4,$

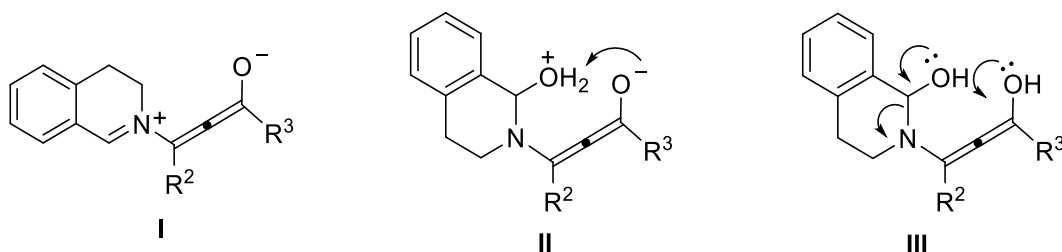

Reactivity toward yrones similar to that of 3,4-dihydroisoquinolines **346** is also exhibited by 3,4-dihydro- β -carboline imine derivatives **348**, but as Cui and co-workers discovered,³⁷¹ additional reactions occurred and dimeric β -carbolines **349** were obtained in up to 80% yield (Scheme 159). Conjugate addition gives intermediate **I** which contains a reactive iminium motif that competes with the ynone and forms zwitterion **II**. This intermediate is not stable but undergoes an intramolecular Mannich reaction which leads to a [2+2+2] annulation reaction and formation of **349**.

Scheme 159. Conjugate Addition of 3,4-Dihydro- β -carbolines **348** to Yrones **71**

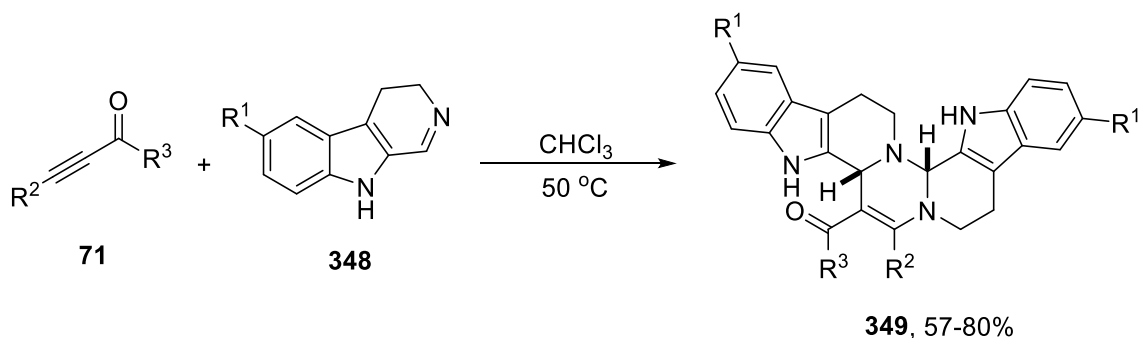

$R^1 = \text{H, MeO, Me, Cl}; R^2 = n\text{Bu, } n\text{Hex}$

$R^3 = \text{Et}_2\text{CH, 2-furyl, Ph, 4-MeC}_6\text{H}_4, 3\text{-MeOC}_6\text{H}_4, 4\text{-MeOC}_6\text{H}_4, 4\text{-ClC}_6\text{H}_4, 3,4\text{-Cl}_2\text{C}_6\text{H}_3, 2\text{-BrC}_6\text{H}_4$

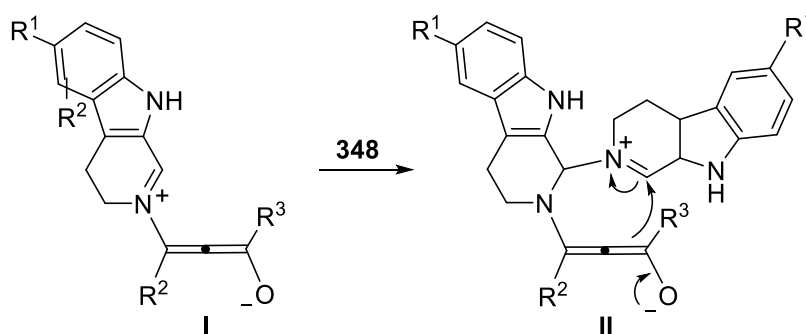

Tertiary amines are nucleophilic, but neutral compounds cannot be formed unless one or several secondary reactions take place. This is illustrated by the reaction between 1,1-diethoxybut-3-yn-2-one (**350**) and triethylamine. When performed in hexane, an exothermic reaction took place and a black, tarry material was formed.^{349,350} In diethyl ether, however, one product, 1-[2,4-bis(diethoxymethyl)-2,4-diethynyl-4*H*-1,3-dioxin-5-yl]-2,2-diethoxyethanone (**351**), was obtained in 53% yield. The product is apparently a trimer of **350**, the formation of which can be envisaged to take place via intermediates **I-III** by the mechanism outlined in Scheme 160.

Scheme 160. Addition of Triethylamine to Ynone **350**

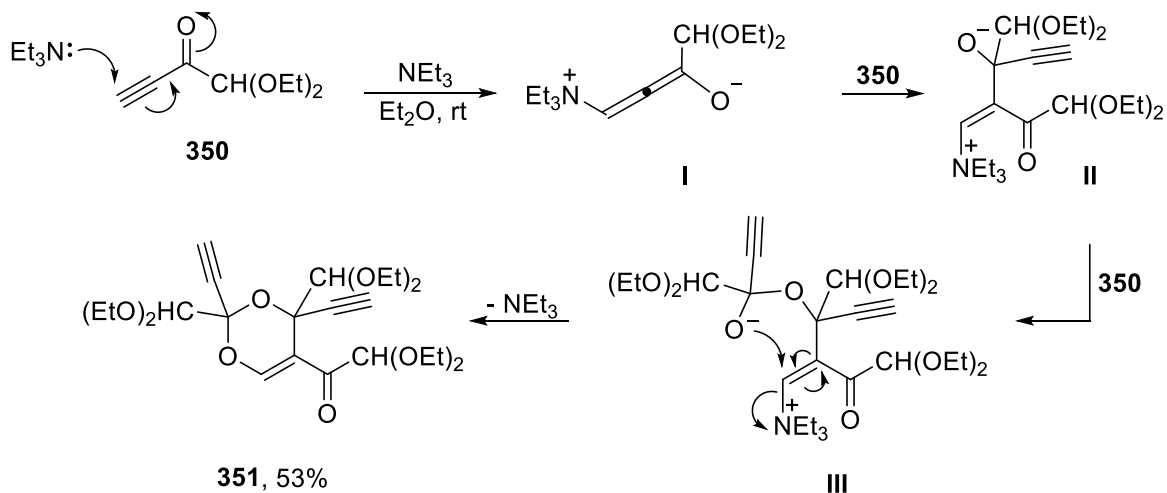

When the diethoxymethyl moiety in **350** was replaced by an azulen-9-yl group **352**, the course of the reaction with tertiary amines changed.⁷⁹ The first step was still conjugate addition of the amine, but a Hofmann elimination then occurred and gave the corresponding β -diethylaminoenone (**353**), as expected with *E* stereochemistry, in excellent yield under the best conditions (Scheme 161). No trimerization was observed, probably due to a higher electrophilicity of the carbonyl group and the significant excess of amine used by Yamaguchi and Sugiyama.⁷⁹ The yield appeared to be amine dependent, and when the amine contained different alkyl groups, several enaminones were formed. Intermediates **I-III** have been proposed to take part in the process.

Scheme 161. Addition of Triethylamine to Azulen-9-yl Ethynyl Ketone (352)

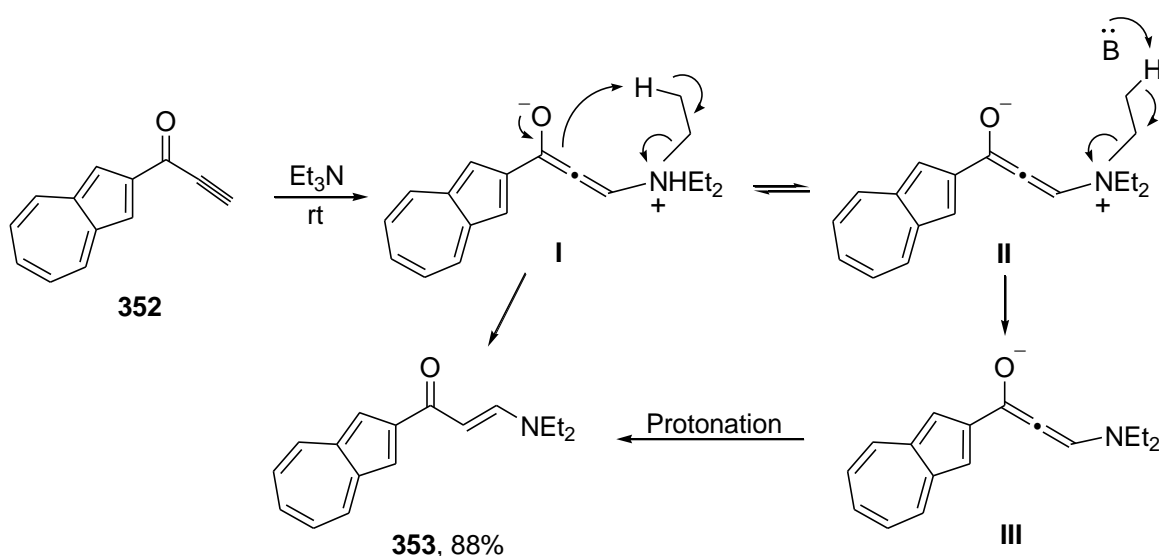

It should be mentioned that many of the enaminones reported in the literature have been exposed, without being isolated, to other reagents to give other products. A crucial factor in these cases is the presence of at least one additional reactive moiety in the enaminones, in a position that makes it possible to interact with the enaminone motif. This is illustrated by the examples in Scheme 162 which show the reactivity of functionalized enaminones **354** under basic conditions with K_3PO_4 (to pyrroles **356**)³⁶⁴ and *t*-BuOK (to pyridines **359**),³⁶⁵ acid catalysis (to benzoquinolinenaphthoquinones **361**),¹⁴ and metal-induced oxidations with cerium(IV) (to pyrroles **357** and **358**),³⁵⁷ copper(II) (to pyrroles **355**)³⁵⁹ and palladium(0) (to quinolones **360**).¹⁵¹

Scheme 162. Preparation of Several Heterocycles 355-361 by Treating Enaminones 354 with Various Reagents

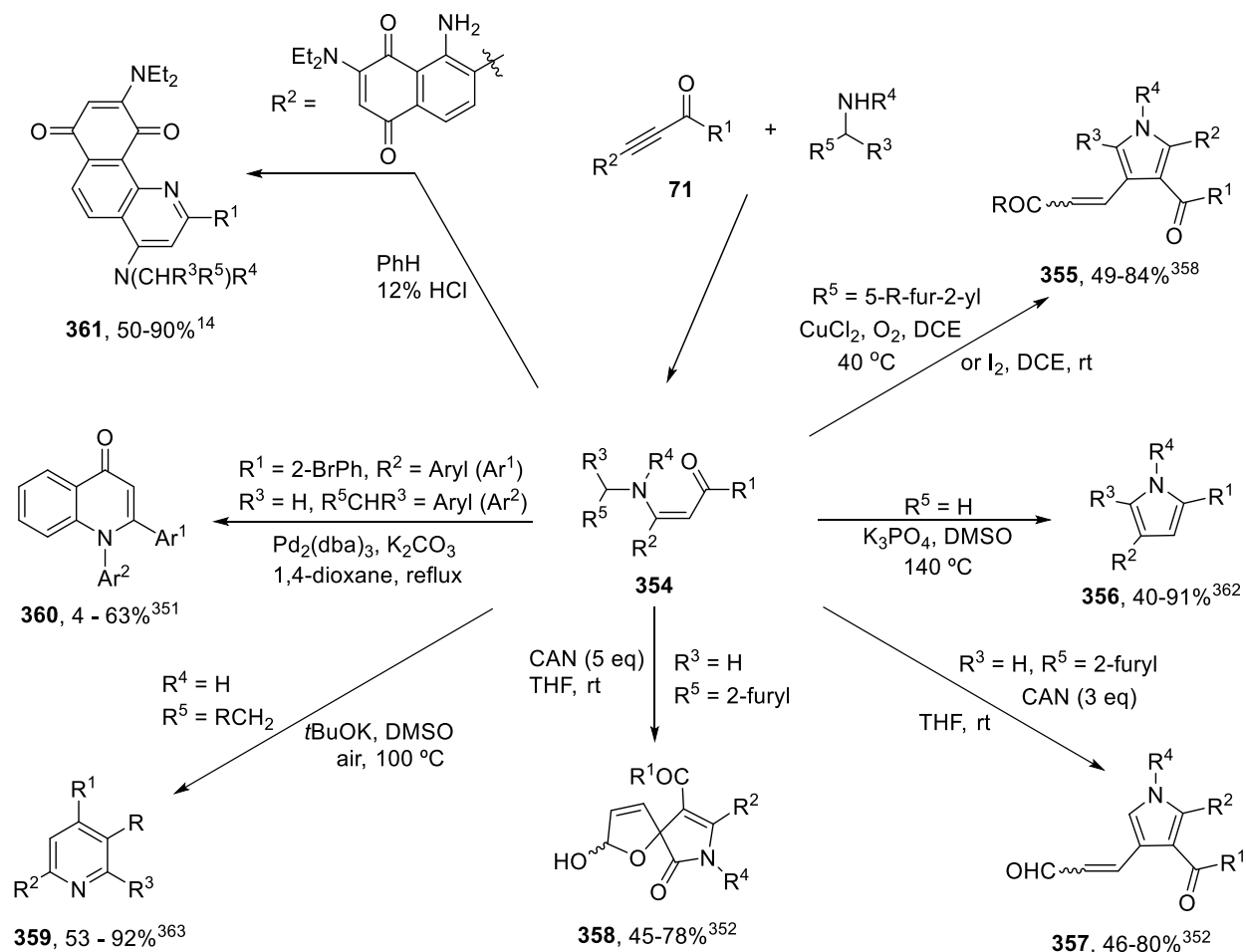

Finally, it should be mentioned that a change of the course of reaction has been observed when primary amines have been reacted with ynones with an aryl β -substituent containing a formyl group in *ortho* position. The change is due to the fact that the amines react faster with the aldehyde than the ynone moiety and give hemiaminals, which then react and provide either functionalized isoindolinones or 3-hydroxyindenamines (Section 3.1.3.1, *Hemiaminals*).³⁷²

As conclusion, primary and secondary amines undergo intermolecular hydroamination under a range of conditions, giving enamminones in variable yields. Most reactions have been carried out with substrates containing a nucleophile that has reacted with the enamminone moiety intramolecularly and afforded cyclic products. Reactions with tertiary amines are unimportant.

3.1.3.1.3. Reactions with Dinucleophiles. A variety of compounds with two or more nucleophilic centers have been reacted with a range of conjugated ynones. Almost without exception the centers are at nitrogen only or at various combinations of nitrogen, oxygen or sulfur. The reagents used the most are dinucleophiles with the two centers directly attached to each other (1,2-dinucleophiles), like hydrazines and hydroxylamine, but some compounds with one or several carbon atoms between the two, 1,(n+2)-dinucleophiles, $n \geq 1$, have also been applied. And when the number of atoms in between is three or larger, the two centers behave in essence independently and react as competing

mononucleophiles. Reactions illustrating this point have been reported by Beletskaya and co-workers.³⁵⁸

Hydrazines. The group of reagents used most frequently is the hydrazines, which can be classified as *N,N*-1,2-dinucleophiles and comprise of hydrazine^{4,28,115,148,155,157,161,185,339,349,350,362,373-375} and a number of *N*-monosubstituted derivatives^{4,28,71,148,155,161,225,373,376-380} thereof. The reactions can be performed under a large variety of conditions; in protic^{28,157,255,373,374,376,380} or aprotic solvents,^{4,161,339,362,376,377,379} in the absence or presence of a catalyst such as Ph_3PAuCl ,^{4,375} AgSbF_6 ,^{4,375} and $\text{Cu}(\text{OAc})_2$,^{4,115,375,377} at room temperature^{4,28,148,161,339,350,373} and up to 150 °C,^{155,161} and in the absence^{28,115,157,225,339,373,376,379} or presence^{148,155,161} of ammonium salts and other by-products formed in previous steps in one-pot multistep syntheses. Almost without exception, the products isolated are the corresponding pyrazoles in good yields, even when the reactants contained one or several moieties known to react with either primary amines, the keto carbonyl group, and conjugated C-C double and triple bonds.^{115,362,363,376,377} This way of making pyrazoles therefore appears quite robust, and it has been used to prepare substituted pyrazoles, for instance trifluoroborates, that subsequently have been utilized as synthetic intermediates in coupling reactions to make a number of complex molecules (Scheme 163).^{28,373}

Scheme 163. Conjugate Addition of Methylhydrazine to Ynones 19 Affording Pyrazoles 362

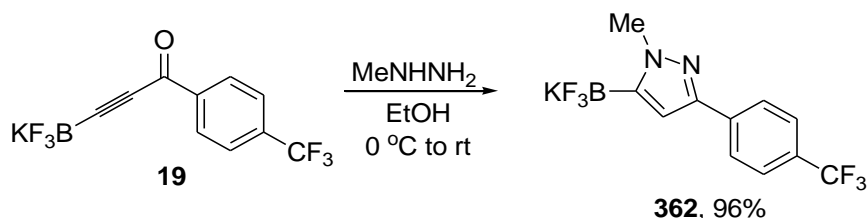

Monosubstituted hydrazines in general give mixtures of isomeric pyrazoles.^{4,28,373,376,377,380,381} The regioselectivity is sensitive to the reaction conditions, as illustrated by the reaction between 1,1,1-trifluoromethyl ynones **363** and *N*-substituted hydrazines. In highly polar aprotic solvents such as DMSO at elevated temperature, the regioselectivity was excellent and **364** were exclusively formed (Scheme 164).³⁷⁷ When metal salts such as $\text{Cu}(\text{OAc})_2$ were added and nonpolar solvents used, the regioselectivity was completely reversed and mainly **365** were formed. In the proposed mechanism, when DMSO was used, a Michael addition of phenylhydrazine to provide intermediates **366** took place, which by cyclization to **367** and dehydration gives the pyrazole **364**. On the other hand, in the Cu-catalyzed process intermediates **I-III** have been postulated to explain the formation of regioisomeric pyrazoles **365**.

Scheme 164. Pyrazoles 364 and 365 from Ynones 363 and *N*-Substituted Hydrazines

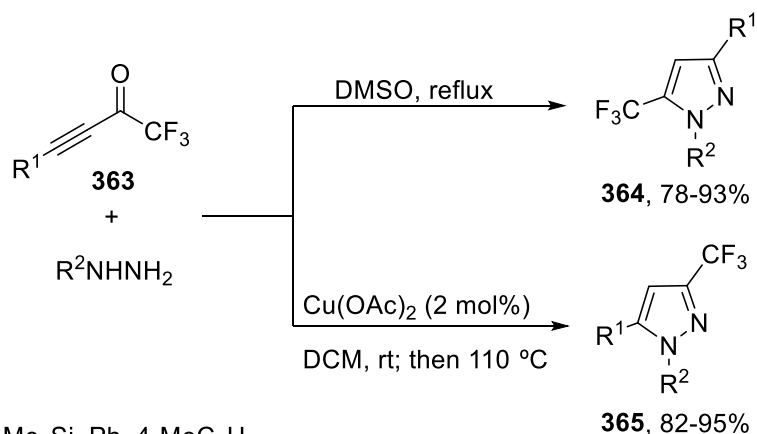

$R^1 = nBu, Me_3Si, Ph, 4-MeC_6H_4$

$R^2 = 2-O_2NC_6H_4, 4-MeOC_6H_4, 4-F_3CC_6H_4, 4-HO_2CC_6H_4, 4-H_2NO_2SC_6H_4, 2,4-Cl_2C_6H_3, tBu, 2-Py, 2-benzothiazolyl$

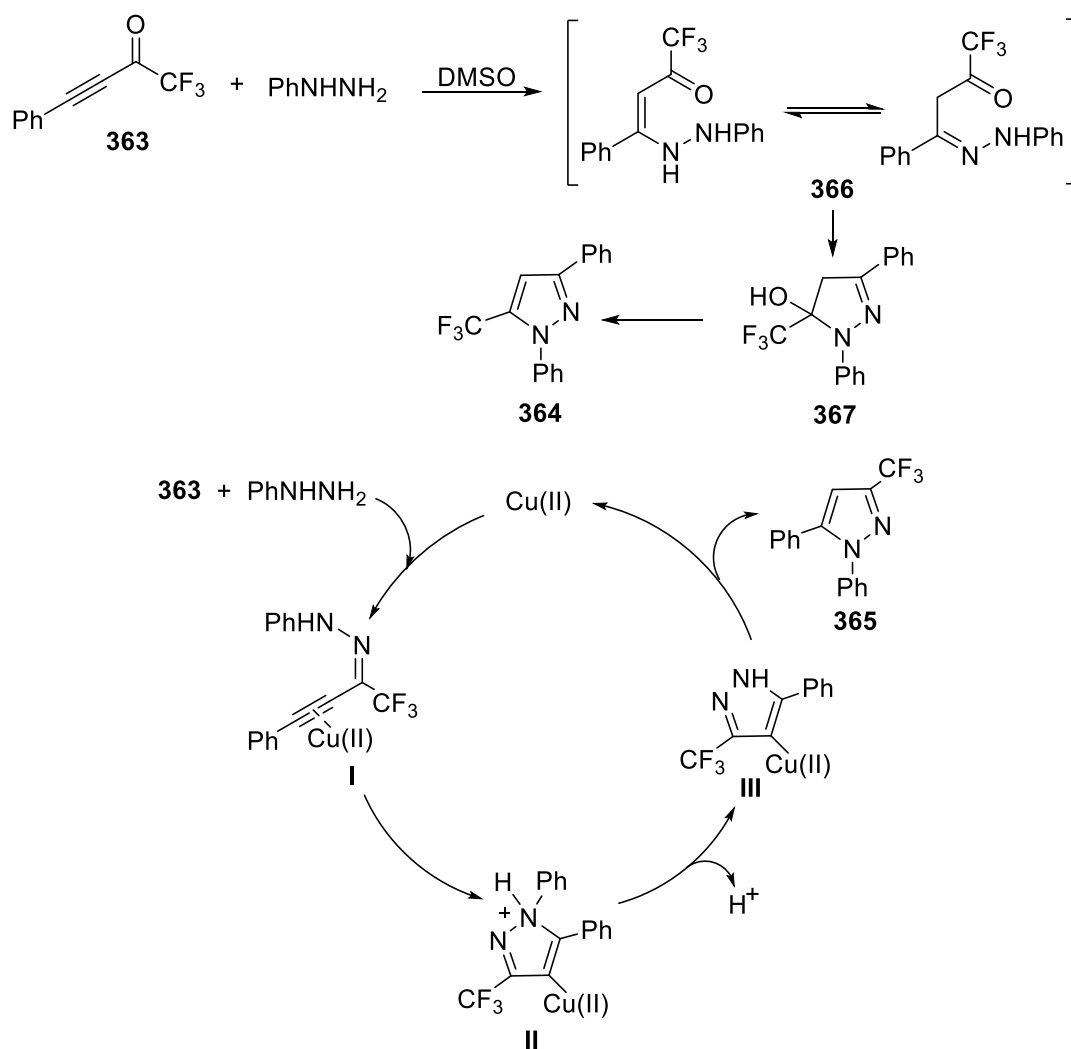

Experiments and computational studies,³⁷⁶ and subsequent modelling have revealed that solvent interactions with intermediates play an important role these reactions, and is the reason why 1,1,1,3,3,3-hexafluoropropan-2-ol (HFIP) appeared to be an excellent solvent for the reaction between 4-aryl-1,1,1-trifluorobut-3-yn-2-one (**363**) and

phenylhydrazine affording pyrazoles **365** in essentially quantitative yields at room temperature (Scheme 165).³⁷⁶

Scheme 165. Pyrazole Formation by Reaction of Yrones **363 and Phenylhydrazine in Hexafluoroisopropanol**

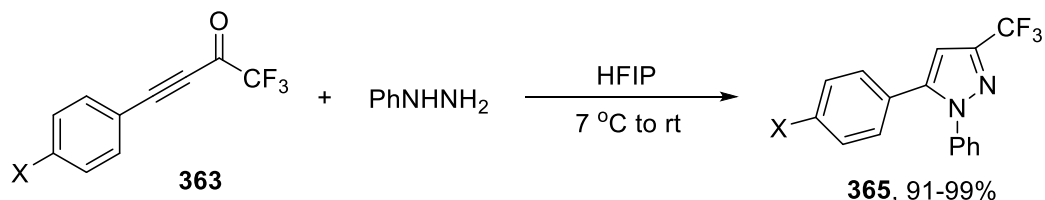

X = H, Cl, Br, Me, *t*Bu, MeO, MeS

Sequential Michael addition and cyclocondensation of hydrazine to ynones is also involved when 6-acyl-5-aryl-2,3-dihydropyranones **368** are reacted with hydrazine in refluxing ethanol and furnish 3,5-disubstituted-1*H*-pyrazoles **369**.³⁸¹ The transformation is initiated by a nucleophilic 1,2-attack of the conjugated dihydropyranone moiety which is followed by a Grob-type fragmentation (C-C and C-O bond cleavages) and concomitant formation of ynones **71** and hydrazides **370** (Scheme 166). These ynones then react with hydrazine and afford the corresponding pyrazoles **369** as a mixture of regioisomers.³⁸¹

Scheme 166. Reaction of Dihydropyranones **368 with Hydrazine Giving Pyrazoles **369****

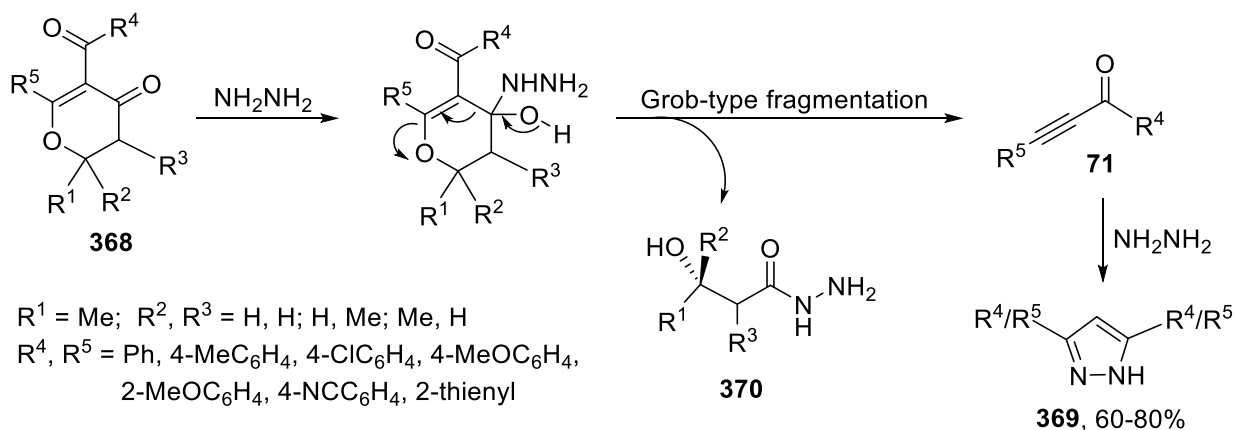

R¹ = Me; R², R³ = H, H; H, Me; Me, H
 R⁴, R⁵ = Ph, 4-MeC₆H₄, 4-ClC₆H₄, 4-MeOC₆H₄,
 2-MeOC₆H₄, 4-NCC₆H₄, 2-thienyl

Finally, it should be mentioned that hydrazine reacts regioselectively with 7-(triisopropylsilyl)-2,2-dimethylhept-4,6-diyne-3-one (**371**) and furnishes 3-*tert*-butyl-5-(2-triisopropylsilylethynyl)pyrazole (**372**) (Scheme 167).³⁰

Scheme 167. Regioselective Formation of Pyrazole 372 from Diynone 371

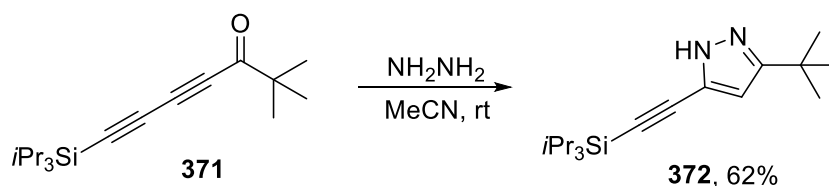

Nitrite. The nitrite ion can function as an N-nucleophile and forms nitro compounds or acts as an O-ligand and forms nitrites, so the ion is a *N,O*-1,2-dinucleophile. In reactions with α,β -ynones the species appeared to react as a nitrogen nucleophile as reported by Marinelli and co-workers.³⁰ They studied the reaction between sodium nitrite and β -(2-aminoaryl)- α,β -ynones **200** under slightly acidic conditions and discovered that conjugate addition of HNO_2 took place, but the primary product (**374**) suffered cyclization and formed 4-nitroquinolines **373** in good yields (Scheme 168). The outcome was catalyst dependent; the best results were obtained with ammonium chloride.³⁰

Scheme 168. Conjugate Addition of Nitrite to Ynones 200 Followed by Cyclization to Quinolines 373

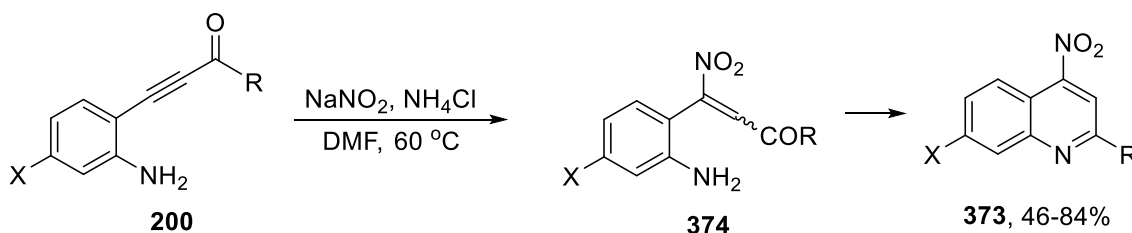

X = H, Cl

R = *n*Pent, Ph, 2-BrC₆H₄, 3-MeC₆H₄, 4-MeOC₆H₄, 4-ClC₆H₄, 4-AcC₆H₄, 3-MeO₂CC₆H₄, 3-F₃CC₆H₄, 2-furyl, 2-thienyl, 1-naphthyl

To conclude, hydrazines react with ynones as dinucleophiles and form pyrazoles, in general in good to excellent yields. Substituted hydrazines form mixtures of isomers in a ratio that is influenced by addition of metal ions, in particular $\text{Cu}(\text{OAc})_2$.

Hydroxylamine. Hydroxylamines can be classified as *N,O*-1,2-dinucleophiles. Only a few ynones have been reacted with this reagent. If no special measures are taken, the expected isoxazoles are not formed at all; the only or main product is the corresponding 5-hydroxy-4,5-dihydroisoxazole derivative which is formed by amino attack of the triple bond, hemiacetalization, and finally, imine formation by double-bond migration. The yields are generally good to excellent.

The simplest ynone reacted with hydroxylamine is 1,1-diethoxybut-3-yn-2-one (**350**), which furnishes 5-diethoxymethyl-5-hydroxy-4,5-dihydroisoxazole in 84% isolated yield.^{349,350} Attempts to convert this compound into the corresponding isoxazole under acidic conditions failed, which is not totally unexpected considering its low empirical resonance-stabilization energy.³⁸² Four hydroxylated derivatives of **350**, such as 1,1-

diethoxy-5-hydroxyalk-3-yn-2-ones (**375**), exhibited the same reactivity and gave 5-diethoxymethyl-5-hydroxy-3-(1-hydroxyalkyl)-4,5-dihydroisoxazoles (**376**) in better than 80% yield (Scheme 169).³⁷⁴ It is noteworthy that the carbonyl group is attacked by the OH group attached to nitrogen and not to C-5; this is due to the *Z*-stereochemistry of enaminone **377** formed in the first step.³⁵²

Scheme 169. Reaction of Ynone **375** with Hydroxylamine

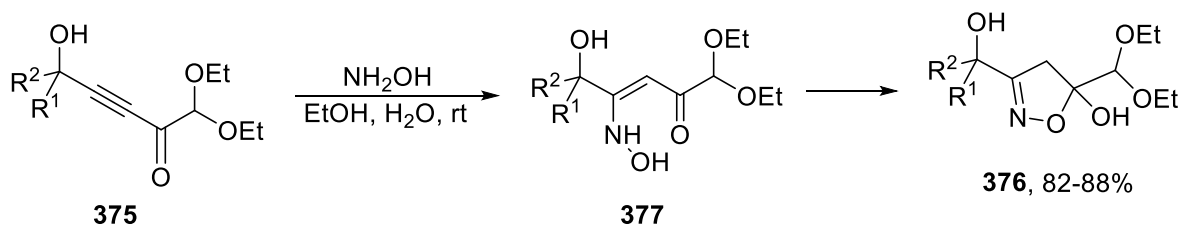

$R^1, R^2 = H, H; H, Me; H, iPr; Me, Me$

Similar reaction conditions were applied by Xie and co-workers who treated alkynyl aryl ketones **71** with a mixture of hydroxylamine hydrochloride and KOH in methanol. The base was used in excess, conceivably to facilitate dehydration and isoxazole formation, but that reaction did not occur, so 5-hydroxy-4,5-dihydroisoxazoles **378** were instead obtained in excellent yields.³⁸³ It is noteworthy that the nature of the aryl substituents did not influence the reaction at all (Scheme 170). However, when the base was changed to acetate and the solvent to THF, dehydration occurred and the expected 3,5-disubstituted isoxazoles **379** resulted in acceptable to good yields.¹⁵⁶

Scheme 170. Synthesis of 5-Aryl-5-hydroxy-4,5-dihydroisoxazoles **378** and 3,5-disubstituted Isoxazoles **379** from Ynones **71** and Hydroxylamine

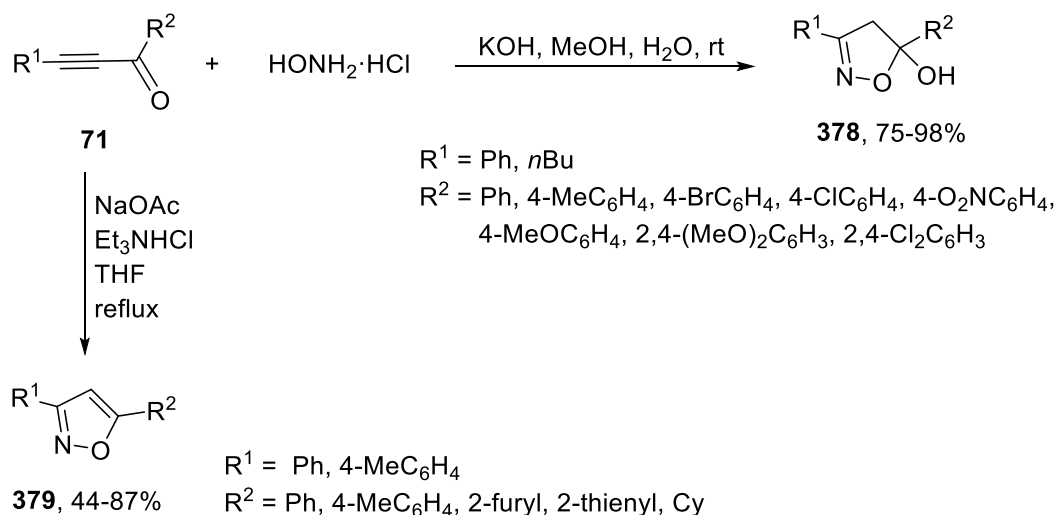

Similar reaction conditions were applied by Svete and co-workers to prepare isoxazolines from Boc-protected α' -aminoyones **100** (Scheme 171).¹⁰² The Boc-protected amino group reacted with the hydrochloride and generated hydroxylamine

which afforded the 5-hydroxy-4,5-dihydroisoxazoles **380** in fairly good yields. Unlike **378**, which did not aromatize under a range of acidic conditions, **380** reacted smoothly when treated with HBr/HOAc at room temperature and gave the corresponding isoxazoles **381**.¹⁰²

Scheme 171. Synthesis of Isoxazoles 381 from Boc-Protected α -Aminoynones 100

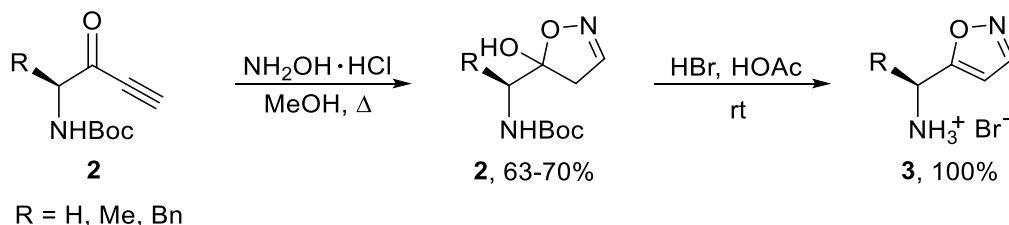

Amidines. Amidines are *N,N*-1,3-dinucleophiles that react with ynones and afford substituted pyrimidines (**382**) if no other functional group intercepts any of the intermediate involved. Although the reaction is simple to carry out, few examples have been reported in the literature probably because the yield is usually below 50%. Reactions with three alkynyl aryl ketones (**71**), carried out under one-pot conditions, illustrate this (Scheme 172).^{139,148} The ketones were made by a Sonogashira reaction and then reacted without isolation with an amidine generated *in situ* to give 2,4,6-trisubstituted pyrimidines **382**.¹³⁹

Scheme 172. One-Pot Synthesis of Pyrimidines 382 from Amidines and *in-situ* Generated Ynones 71

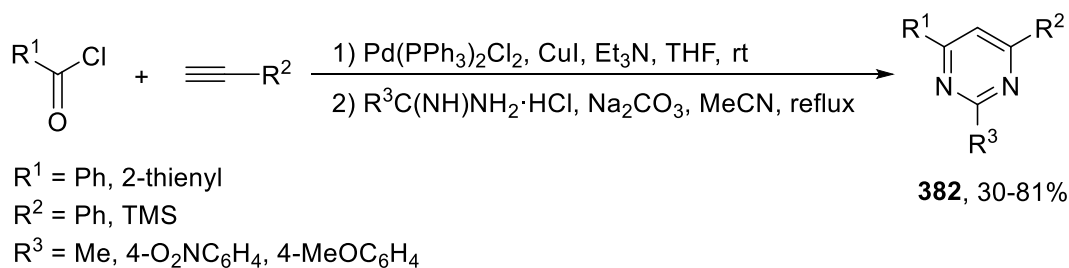

Amidine addition to ynones was also applied by Svete and co-workers to convert (*S*)-*N*-Boc-alanine-derived ynones **100** into the corresponding *tert*-butyl (*S*)-(1-(pyrimidin-4-yl)ethyl)-carbamates **383** (Scheme 173).³⁸⁴ The reactions were easy to perform, but the yields were low, and the *ee* values for the optically active products were not determined. However, removal of the Boc group under standard conditions (2M HCl/EtOAc) was uneventful and furnished most of the corresponding free 1-(pyrimidin-2-yl)ethylamines in better than 80% yield.³⁸⁴

Scheme 173. Reaction of Amidines with Boc-Protected α' -Aminoynones 100

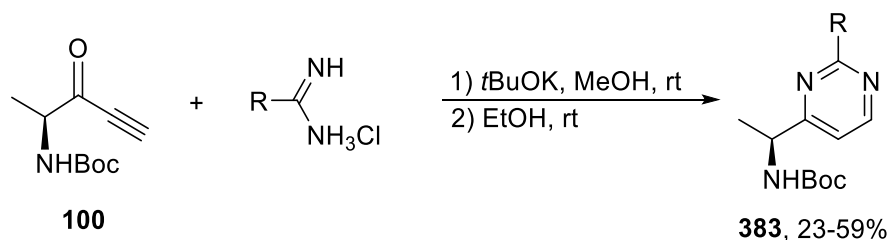

R = H, Me, Ph, 3-O₂NC₆H₄, 4-H₂NC₆H₄, 1*H*-benzo[d]imidazol-2-yl, 1*H*-pyrazol-1-yl

It should also be mentioned that benzamidine, generated *in situ* from the corresponding hydrochloride, reacts regioselectively with 5-(triisopropylsilyl)-1-phenylpent-2,4-diyne-1-one (**305**) and furnishes 2,6-diphenyl-4-(2-triisopropylsilylethynyl)pyrimidine (**384**) (Scheme 174).³³⁹

Scheme 174. Regioselective Pyrimidine **384** Formation from Diynone **305**

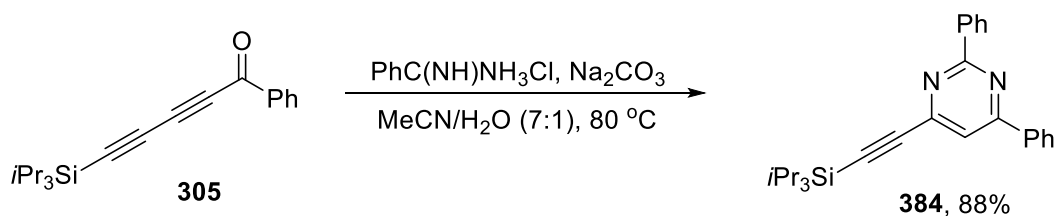

A change of the course of reaction is observed when amidine derivatives with the general structure R²C(NH)NHR¹ are reacted with 2-(2-aminophenyl)ethynyl 4-chlorophenyl ketone (**200**).³⁶³ The final product depends on the structure of the amidine, but in any case, the pyrimidine formation is prevented by aniline interception of the primary product. When R¹ = H and R² ≠ H, quinolines **385** are formed in excellent yields, but when both R¹ and R² ≠ H quinazolines **386** were obtained, also in excellent yield (Scheme 175). The conceivable intermediate **I** suffers aniline trapping and gives **385** by attack of the carbonyl group (pathway a) and **386** by attack of the amidine motif (pathway b). Finally it should be mentioned that 3*H*-quinazolin-4-ylideneethanones are formed in high yield when **200** reacts with *N*-imidoyliminotriphenylphosphoranes [RC(NR¹)NPPH₃]; in these cases HN=PPh₃ is released instead of primary amine R¹NH₂.³⁶³

Scheme 175. Reaction Between Ynone 200 and Amidines

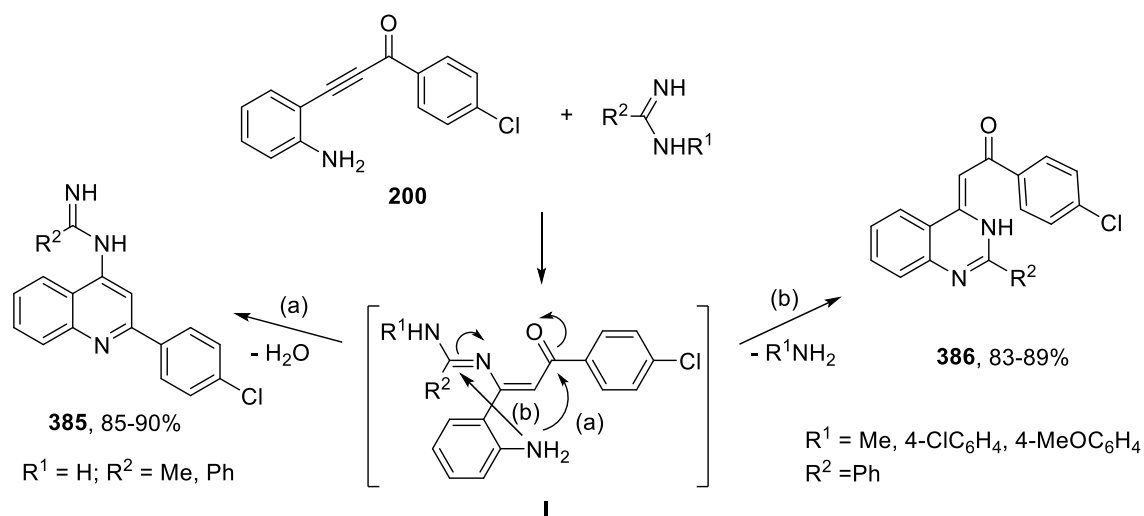

Svete and co-workers have also reacted ketone **100** with three unsymmetrical cyclic amidine derivatives, 3-aminopyrazoles **387**, and obtained in each case one major product, a *tert*-butyl (*S*)-(1-pyrazolo[1,5-*a*]pyrimidin-7-yl)ethyl)carbamate derivative (**388**), and in two cases one minor product, a *tert*-butyl (*S*)-(1-pyrazolo[1,5-*a*]pyrimidin-5-yl)ethyl)carbamate derivative (**389**) (Scheme 176).³⁸⁴ The formation of both products starts with a nucleophilic 1,4-attack of the ynone **100**, either by the primary amino group (path a) or the ring NH group (path b), and intermediates **I** and **II**, respectively, thus formed, suffer condensation by attack of the carbonyl group and furnish **388** and **389**, respectively, through the hydroxy derivatives **390**, **391**, respectively.

Scheme 176. Reaction of α -Aminoyones 100 with 3-Aminopyrazoles 387

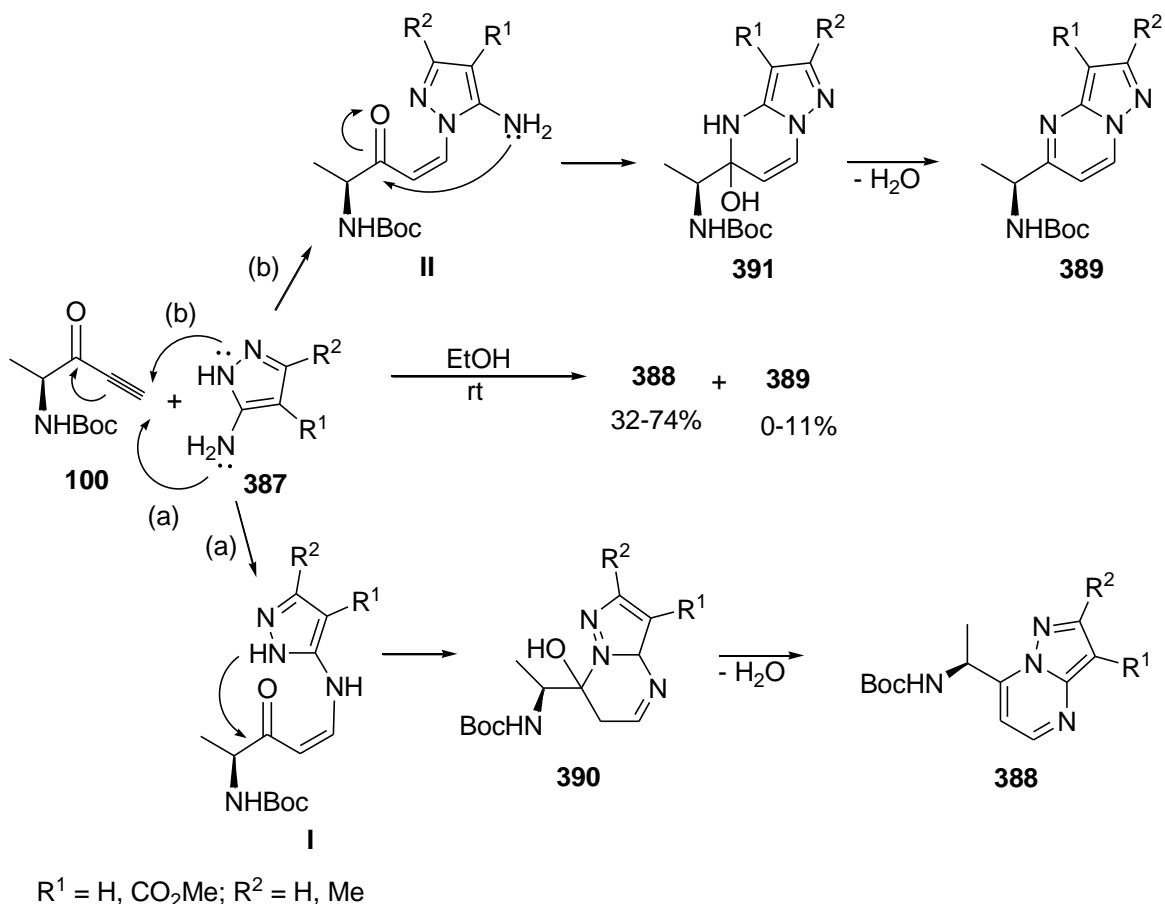

Hemiaminals. These compounds are *N,O*-1,3-dinucleophiles that are not isolable, but are the first intermediate formed when amines react with aldehydes and ketones to form imines. Cao, You and co-workers discovered that if such dinucleophiles are generated in reactions with a formyl group *ortho* to a 3-oxoalk-1-ynyl substituent, the imine formation is intercepted and products different from enaminones are obtained.³⁷² Exploratory experiments revealed that two main types of products, isoindolinones and 3-hydroxyindenamines, were formed when primary amines were used. When so-called small amines were reacted with *o*-alkynylarylaldehydes **392**, that are not very electron poor, **393** were exclusively obtained. The reaction is a multistep process involving many intermediates including **I-IV** (Scheme 177). However, when sterically demanding amines were used, **394** were obtained in up to 92% yield (Scheme 178). On this basis, Cao, You and co-workers argued that addition of NEt_3 to the reaction medium could prevent conjugate addition of any hemiaminal to the ynone. That turned out to materialize; when small amines (RNH_2) were reacted with *o*-(3-oxobut-1-ynyl)benzaldehyde (**392**, $R^1 = \text{H}$; $R^2 = \text{Me}$) in the presence of NEt_3 , ketone **394** was obtained in up to quantitative yield in a multistep reaction passing through intermediates **I-IV** (Scheme 178). Enone **IV** gives 3-hydroxyindenamine **394** by a Petasis-Ferrier rearrangement.³⁷² Whether the proton abstraction in the conversion of **III** to **IV** is an intramolecular transformation or not has not been proved; an intermolecular reaction seems in fact to be more likely.

Scheme 177. Reaction of Ynone 392 with Primary Amines

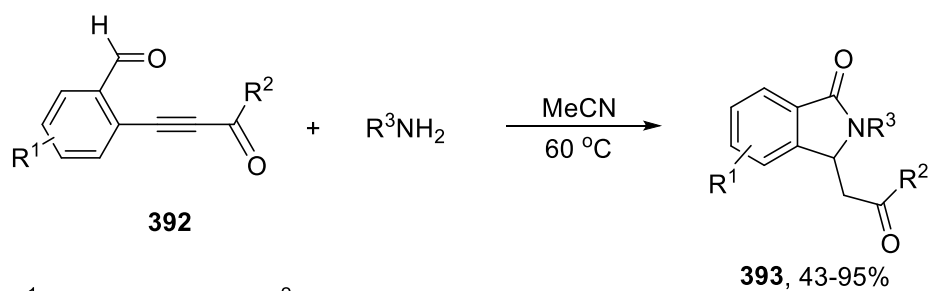

$R^1 = H, F, Cl, MeO$; $R^2 = Me, Ph, 4-MeOC_6H_4, 4-BrC_6H_4$
 $R^3 = Bn, 4-MeOBn, nPr, nBu, iBu, iPr, cPr, cBu, cPent,$
 $HO(CH_2)_2, MeO(CH_2)_2, (fur-2-yl)CH_2, HCCCH_2$

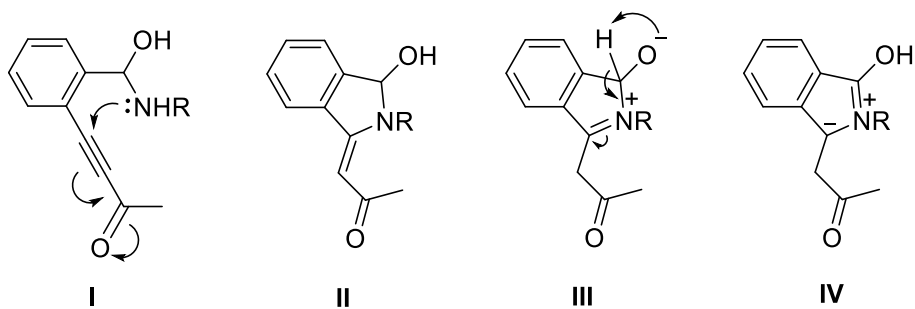

Scheme 178. Regioselective Reaction of Ynone 392 with Amines

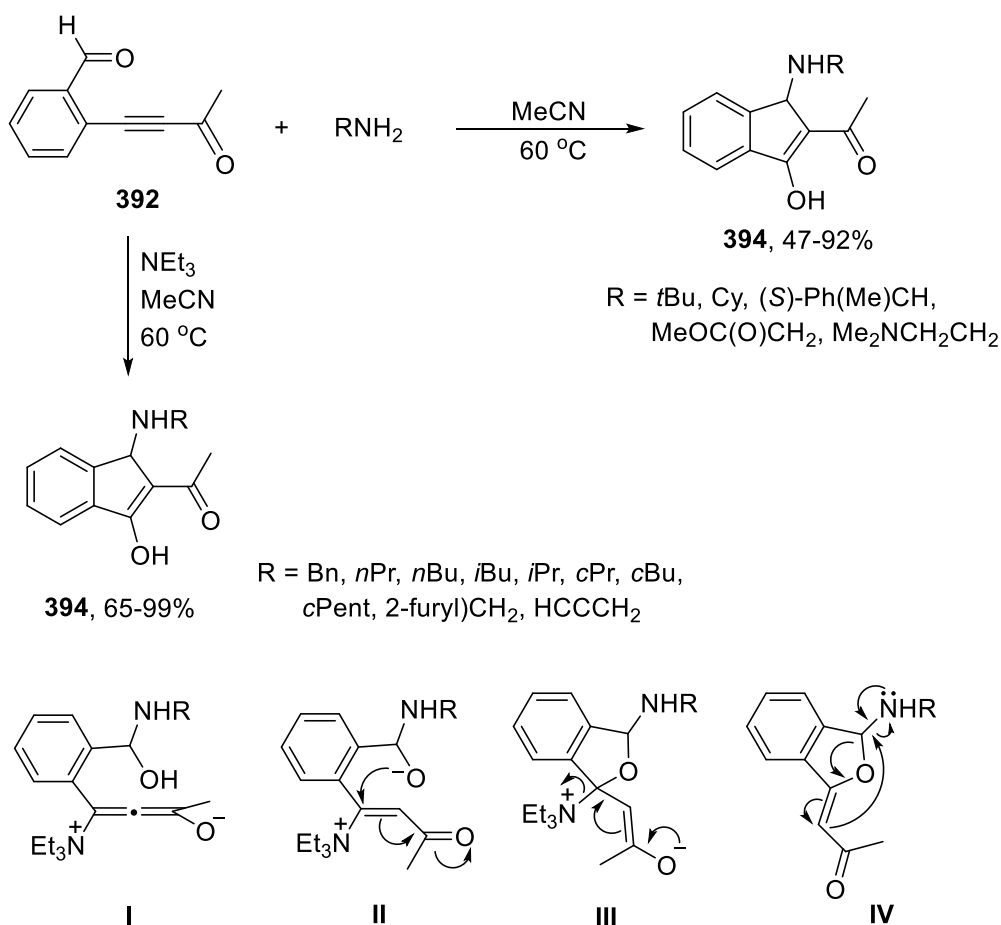

Guanidines. Guanidine, which can be classified as *N,N*-1,3-dinucleophile, react with ynones to give 2-aminopyrimidines. The reactions are usually carried out by treating mixtures of ynone and guanidinium chloride with a base, usually a carbonate^{139,162,182,183,225} but also sodium hydride,^{349,350,374} in various solvents at temperatures ranging from room temperature to 120 °C. The corresponding 2-aminopyrimidine derivatives were generally obtained in fairly good yields.^{162,182,183,350}

Some applications of the transformation is illustrated in Scheme 179. The ynone 1,1-diethoxybut-3-yn-2-one (**350**) reacts with guanidine affording 4-diethoxymethyl-2-aminopyrimidine (**395**) in almost quantitative yield when NaH was applied to generate the guanidine.^{349,350} However, when chain-elongated derivatives of **350** with a hydroxyl group in propargylic position were reacted under the same conditions, the pyrimidine yield dropped significantly due to by-product formation, conceivably caused by the lability of the OH group.³⁷⁴ Cleaner decomposition was observed when a TMS group is attached to the triple bond; this group suffers proton-induced cleavage and the product becomes the corresponding 2-amino-4-arylpyrimidines with no substituents at C5 and C6 (**396**).^{139,182,183} However, ynones **71** with less reactive functional groups, such as heterocyclic aromatic moieties and alkyl groups, reacted cleanly and furnished the expected pyrimidines in high yields.¹⁶² This reactivity was utilized by Müller and co-workers¹⁶² to prepare indol-3-yl-substituted pyrimidines **397**, which are structurally

related to marine natural products belonging to the meridianin class of compounds and have displayed a considerable potential as kinase inhibitors.³⁸⁵

Scheme 179. Reaction of Ynones **350** and **71** with Guanidine

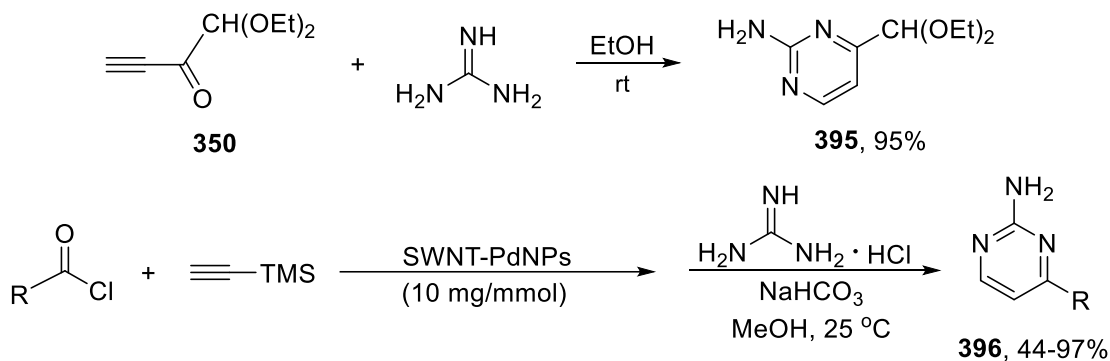

R = *t*Bu, 1-adamantyl, Ph, thien-2-yl, fur-2-yl, 1-naphthyl, 2-naphthyl, (*E*)-PhCH=CH,

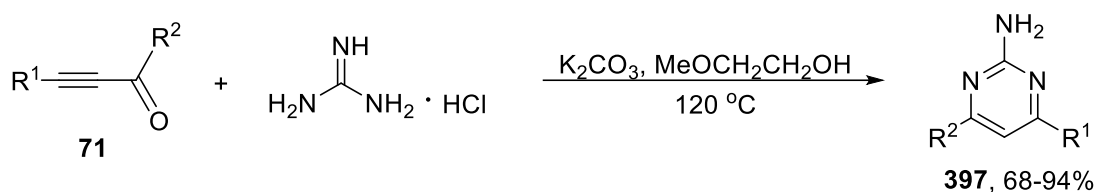

R¹ = indol-3-yl, *N*-Me-indol-3-yl, *N*-Bn-indol-3-yl, 7-aza-*N*-Me-indol-3-yl,
7-aza-*N*-Bn-indol-3-yl, *N*-Me-pyrrol-2-yl
R² = *n*Bu, MeOCH₂, Ph

Two 1-alkynyl ferrocenyl ketones (**195**) have also been reacted with a substituted guanidine, 4-benzoylamino-4-ethoxycarbonylbutylguanidine (**398**). The reaction proceeded smoothly and gave the expected pyrimidines **399** albeit in rather low yields (Scheme 180).²²⁵

Scheme 180. Reaction of Ferrocenyl Ketones **195** with Guanidine Derivative **398**

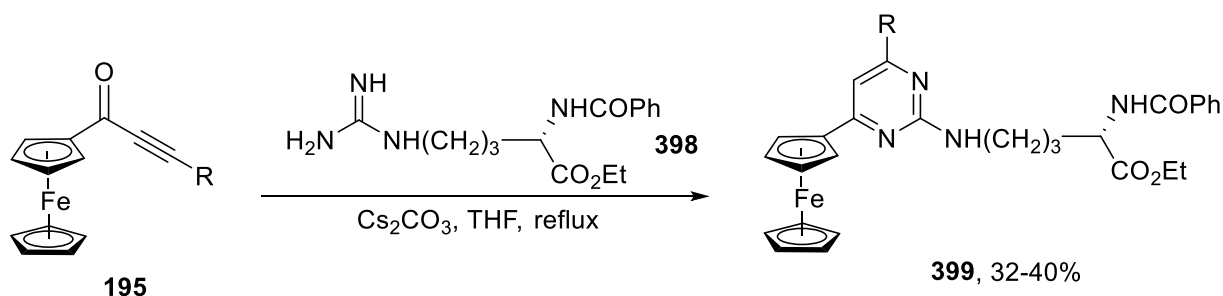

R = *n*Bu, Ph

Another compound that can be regarded as a guanidine derivative is methyl 5-amino-1*H*-1,2,4-triazole-3-carboxylate (**400**) which has been reacted with (*S*)-*N*-Boc-alanine-derived ynone **100** by Svete and co-workers.³⁸⁴ A smooth reaction occurred and afforded methyl (*S*)-7-{1-[(*tert*-butoxycarbonyl)amino]ethyl} [1,2,4]-triazolo[1,5-*a*]pyrimidine-

2-carboxylate (**401**) in 81% yield, conceivably via intermediate **402** which is aromatized by dehydration (Scheme 181).

Scheme 181. Reaction of Ynone 100 with 5-Amino-1,2,4-triazole 400

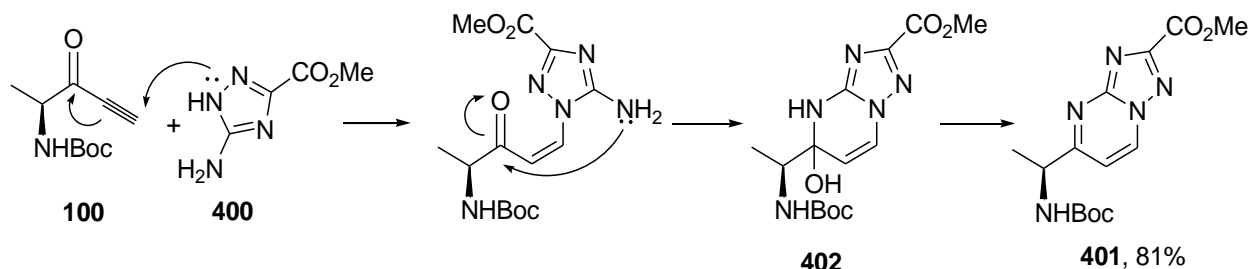

o-Phenylenediamines. *o*-Phenylenediamines (**403**), which can be classified as a *N,N*-1,4-dinucleophile, usually undergo a Michael addition followed by a cyclocondensation when reacted with ynones and afford benzodiazepine derivatives **404**. Srinivasan and co-workers performed the first thorough study of the reaction when they prepared a large number of such derivatives in a two-step, one-pot synthesis under aqueous conditions; the first step was synthesis of the required ynones by Pd(II)-catalyzed coupling of aromatic acid chlorides with arylethyne, the second being addition of phenylenediamines (Scheme 182).¹⁷⁴ In general, yields in both steps were excellent irrespective of the substituents attached to the aryl groups. However, attempts to use 1,2-diamino-4-nitrobenzene as the phenylenediamine reagent failed.¹⁷⁴ It is also noteworthy that the reactions between 1,2-diamino-4-methylbenzene and ynones where $Ar^1 \neq Ar^2$ are regioselective and give only the isomer with Ar^1 closest to the methylated benzodiazepine carbon. A corollary of this is that the first step, the Michael addition, involves the amino group *para* to the methyl group, not the one that is in the *meta* position.

Scheme 182. Synthesis of Benzodiazepines 404 from *in-situ* Generated Ynones 71 and *o*-Phenylenediamines 403

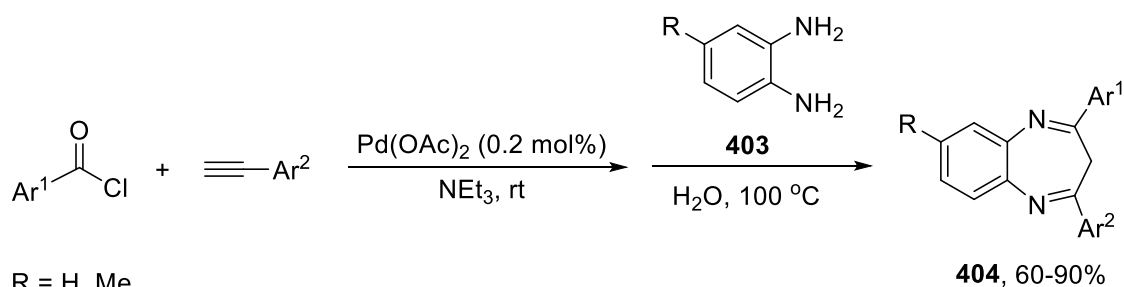

R = H, Me

Ar^1 = Ph, 4-ClC₆H₄, 4-MeC₆H₄, 4-MeOC₆H₄, 2-MeC₆H₄, 2-thienyl, 2-furyl

Ar^2 = Ph, 4-MeC₆H₄, 4-MeOC₆H₄, 3-FC₆H₄, 4-F₃CC₆H₄

An even more extensive study has been published by Cui and co-workers who in particular varied the substituent at C-4 in the *o*-phenylenediamine (**403**) much more

widely.³⁸⁶ The benzodiazepines **404** were not isolated because the syntheses were the first step in two-step, one-pot preparations of quinoxalines **405** which were obtained by a base-promoted CH₂-extrusion of **404** (Scheme 183). Thus, the yields are the outcome of the two-step synthesis. The general trends are the same as reported by Srinivasan¹⁷⁴ with respect to both substituent influence and regioselectivity. It should also be noted that 2,3-diaminonaphthalene reacted in the same fashion as *o*-phenylenediamine and gave the corresponding naphtho[2,3-*b*][1,4]diazepines, albeit in rather low yield (43-46%).³⁸⁶ Finally, it should be added that a number of benzodiazepines have been prepared in good yield by treating β,γ-unsaturated ynones with various *o*-phenylenediamines, the key step being the isomerization of the primary products, β,γ-unsaturated enaminones, to the corresponding α,β-unsaturated analogues which undergo the expected condensation.³⁸⁷

Scheme 183. Synthesis of Benzodiazepines **404** and Quinoxalines **405** from Ynones **71** and *o*-Phenylenediamines **403**

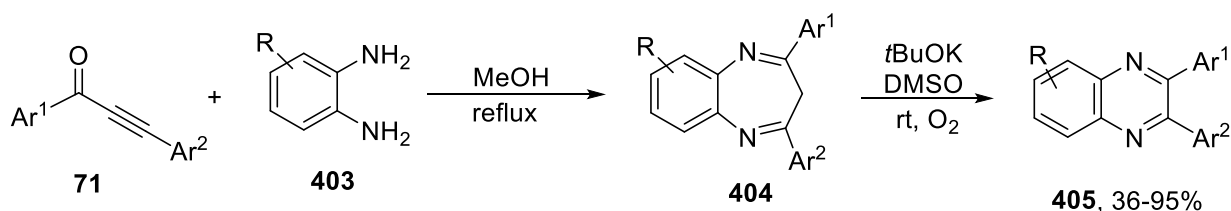

Ar¹ = Ph, 2-MeC₆H₄, 4-MeC₆H₄, 4-MeOC₆H₄, 4-F₃CC₆H₄, 4-*t*BuC₆H₄, 4-FC₆H₄, 4-ClC₆H₄, 3,4-Cl₂C₆H₃, 2-BrC₆H₄, 4-BrC₆H₄, 2-naphthyl, 2-furyl, 2-pyridyl, Cy, *c*Pr, *i*Pr
 Ar² = Ph, 4-MeOC₆H₄, 2-pyridyl, *i*Pr
 R = H, 3-Me, 4-Me, 4,5-Me₂, 4-F, 3-Cl, 4-Cl, 4-Br, 4-CF₃, 4-*t*Bu

The reflux conditions applied by both Srinivasan and Cui are probably quite instrumental to achieve condensation and imine formation at the carbonyl group after the Michael addition because when ynone **350** was reacted with *o*-phenylenediamine in ethanol at room temperature, the reaction stopped after the first step and furnished conjugated enaminone **406** stereoselectively with *Z* configuration (Scheme 184).^{349,350}

Scheme 184. Conjugate Addition of *o*-Phenylenediamine (**403**) to Ynone **350**

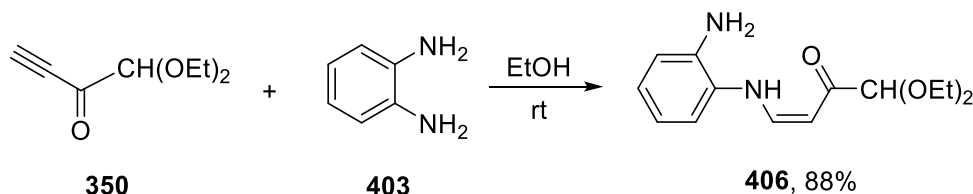

Ethylenediamine. This is a *N,N*-1,4-dinucleophile which has barely been reacted with ynones, but appears to give products that are sensitive to the reaction conditions applied. This was clearly illustrated when ynone **350** was reacted and furnished both monoadduct **407** and bisadduct **408** (Scheme 185) in a ratio that was sensitive to the reaction conditions, in particular the time of reaction.^{349,350} Investigations of the stability of the

products revealed that **407** suffers disproportionation and forms **408** and diamine upon storage at room temperature, whereas **408** react with diamine under the same conditions and gives two molecules of **407**. Thus, the product composition is the result of the overall equilibrium position of two reversible, interconnected reactions.

Scheme 185. Reaction of Ynone 350 with Ethylenediamine

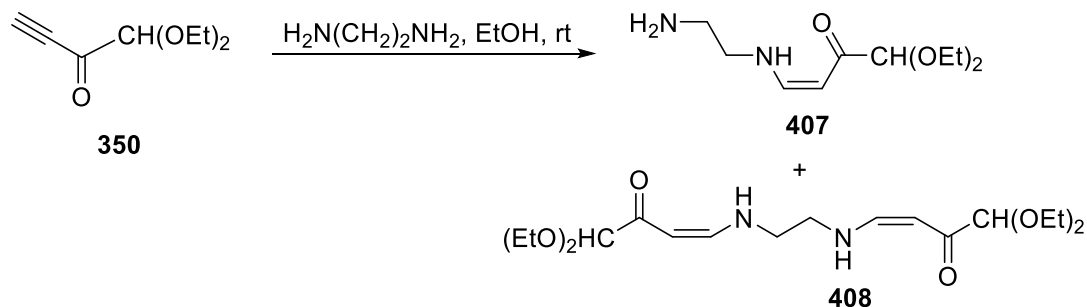

Similar results were obtained by Alabugin and co-workers when ynones **71**, with an internal carbon-carbon triple bond, were reacted.³⁸⁸ When the reactions were carried out at 25 °C, monoadduct **409** and bisadduct **410** were the only products obtained, but at temperatures above 100 °C, extensive decomposition to 4-fluoroacetophenone and 4,5-dihydro-1*H*-imidazole derivatives occurred (Scheme 186). Computational studies indicated that the fragmentation was triggered by generation of a cyclic aminal (**411**), formed by Michael addition of the primary amino group to the enone moiety in monoadduct **409**.³⁸⁸

Scheme 186. Reaction of Ynone 71 with Ethylenediamine

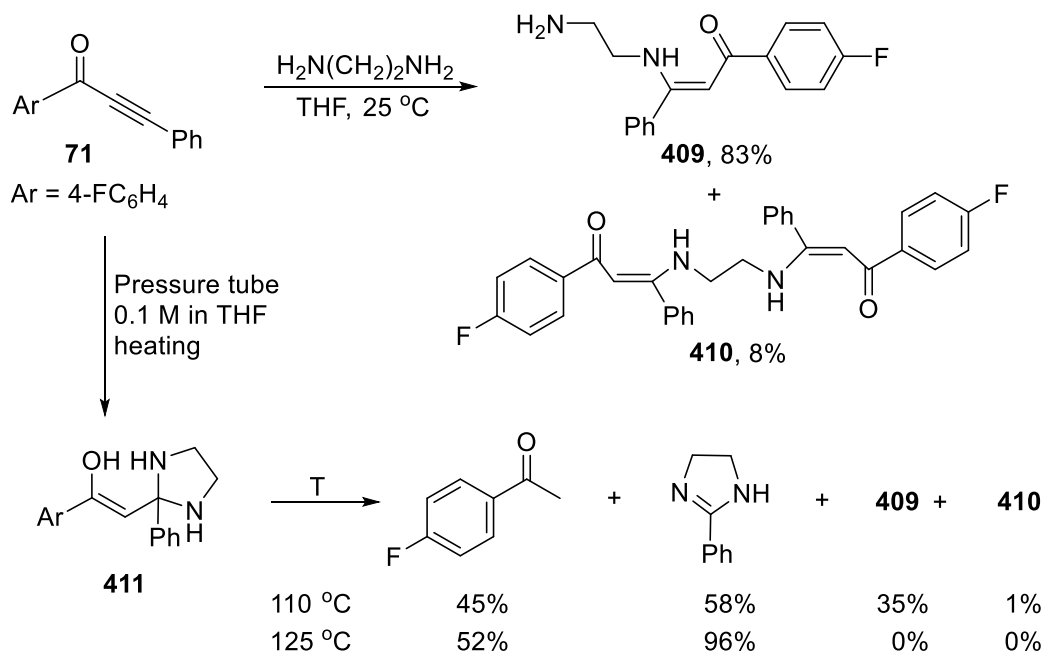

o-Aminobenzamides. These amides **417** are *N,N*-1,5-dinucleophiles, which Cheng, Cui and co-workers have applied to convert ynones **71** to 4(3*H*)-quinazolines **413**.³⁸⁹ The best yields were obtained in toluene at 90 °C in the presence of TFA. Several other solvents were almost as good, but the yield dropped significantly when NMP, DMF, and H₂O were used. In the absence of TFA no product was formed. As far as the substrate is concerned, the yield is good to excellent as long as the alkynyl group is not very electron poor. The same is the case with the dinucleophile, methylated and halogenated derivatives give just as high yields as *o*-aminobenzamide (**412**, R¹ = R² = H) (Scheme 187).³⁸⁹ The reaction is rather complex because the triple bond is cleaved and acetophenone concomitantly released in the last step of the transformation. A plausible reaction mechanism is outlined in the Scheme: after formation of enaminone **414** cyclization to products **413** occurred through intermediates **I** and **II**. It should also be mentioned that 2-aminothiophene-3-carboxamide reacts similarly to *o*-aminobenzamide and gives the corresponding product in 45% yield.³⁸⁹

Scheme 187. Synthesis of 4(3*H*)-Quinazolines **413 from Ynones **71** and *o*-Aminobenzamides **412****

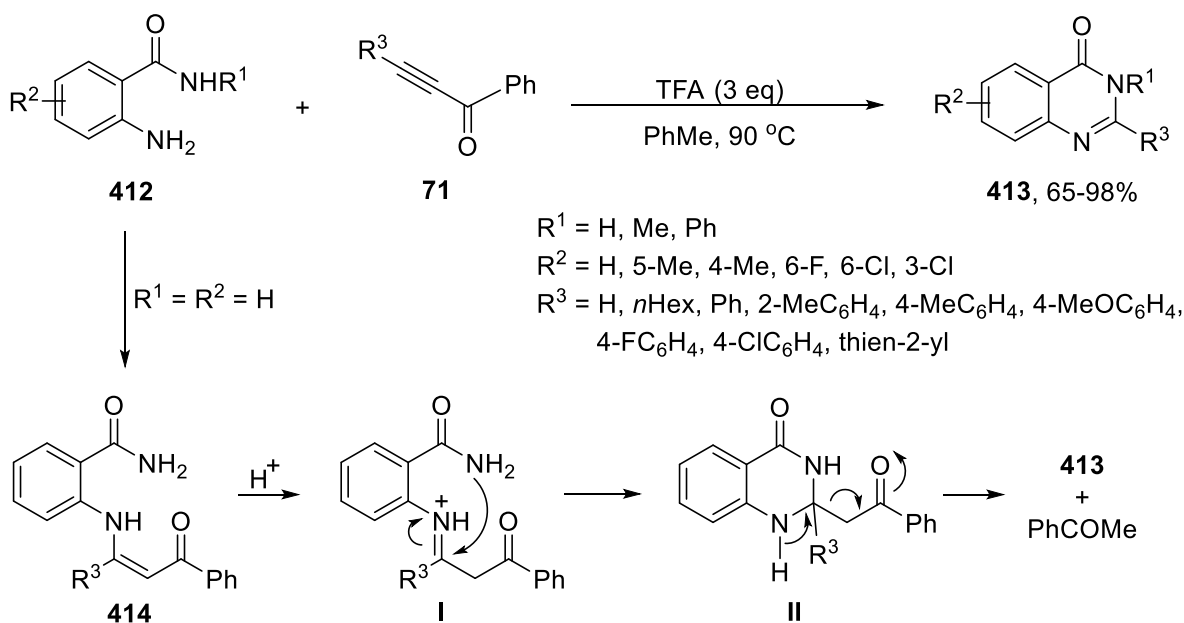

3.1.3.2. Oxygen Nucleophiles. The variety of oxygen nucleophiles that have been reacted with ynones, is limited. Most reactions have involved alcohols, and some have been carried out with alkoxides. Another feature is the predominance of intramolecular reactions, which is probably related to the somewhat limited stability of acyclic vinyl ethers.

3.1.3.2.1. Intramolecular Reactions. Most intramolecular conjugate-addition reactions with oxygen nucleophiles involve alcohol motifs properly positioned relative to the ynone β -carbon. Proper positions are those carbon atoms that allow formation of 5-

or 6-membered oxygen heterocycles. In addition, some activator must usually be added to increase the electron-density difference between β -C and the nucleophilic center(s).

Activation by Acids. The activators used most frequently are various Brønsted acids, of which *p*-toluenesulfonic acid (PTSA) predominates. The reactions with this acid are usually performed in benzene or toluene at room temperature with a reaction time up to 24 h in some cases.^{23,57,86,390} Under these conditions, dihydroxylated α,β -unsaturated internal ynones have given spiroketal substructures and dioxabicycloalkane motifs, found in highly oxygenated natural products, in excellent yields with retention of configuration at stereocenters and with minimal by-product formation. Applications of this powerful transformation are shown in Scheme 188.

Scheme 188. Synthesis of Fragments of Various Natural Products (415, 417, 419 and 421) by Intramolecular Conjugate Additions of Alcohols to Ynones 13, 416, 418 and 420

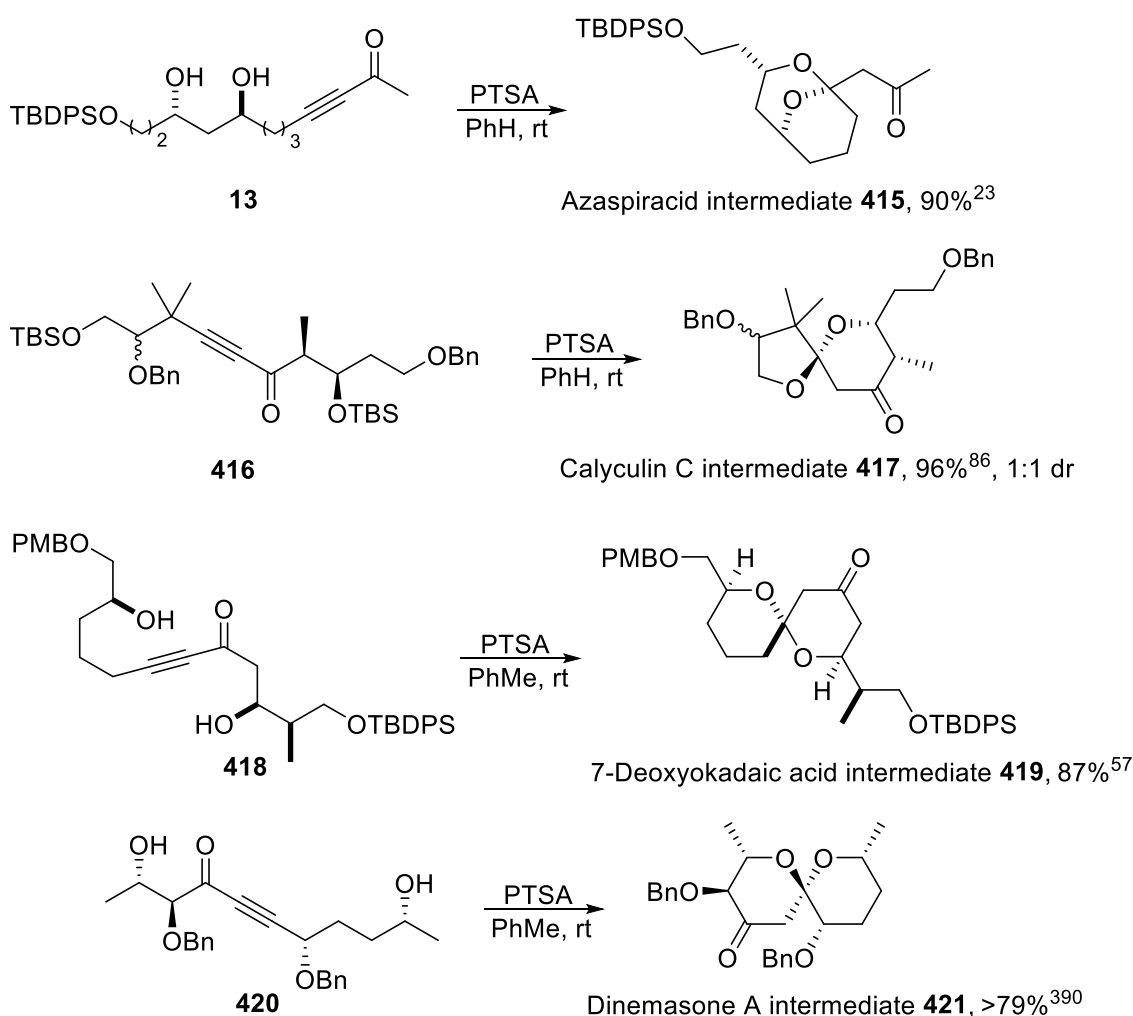

When only one OH group is properly positioned to react with the ynone moiety, other acids have consistently been applied. Thus, Tietze and co-workers completed the synthesis of a new antitumor agent, 4*H*-anthra[1,2-*b*]pyran-4,7,12-trione (**422**), by refluxing ynone **51** for a short time in HOAc containing a few drops of H₂SO₄ (Scheme

189).⁵³ The reaction is a two-step process; first the two ethers are cleaved and then the phenol group in the vicinity of the ynone undergoes conjugate addition.

Scheme 189. Synthesis of 4*H*-Anthra[1,2-*b*]pyran-4,7,12-trione (422) by Intramolecular Cyclization of Ynone 51

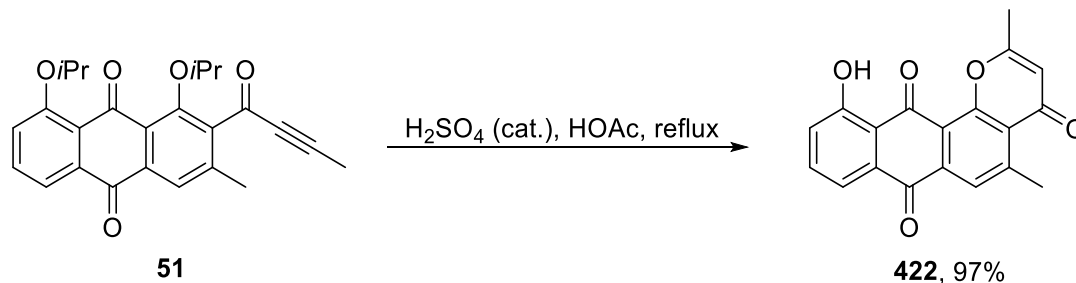

Conjugate addition of phenols under acidic conditions was investigated thoroughly by Doi and co-workers who converted *o*-alkynoylphenols **423** to γ -benzopyranones **424** in high yield (up to 96%) under optimum reaction conditions.³⁹¹ Many acid catalysts gave no product, but when cyclization occurred, the β carbon was attacked regioselectively; no aurone due to α attack was observed. A library of benzopyranones was then prepared with application in natural-product synthesis in mind (Scheme 190). Mechanistically, the reaction appears not to be a conjugate addition of phenols to ynones; first triflic acid attacks and forms vinyl ester **425**, which is subsequently attacked by the phenol giving a pyranone moiety after expulsion of the triflate.

Scheme 190. Synthesis of Flavones 424 by Intramolecular Cyclization of Ynones 423

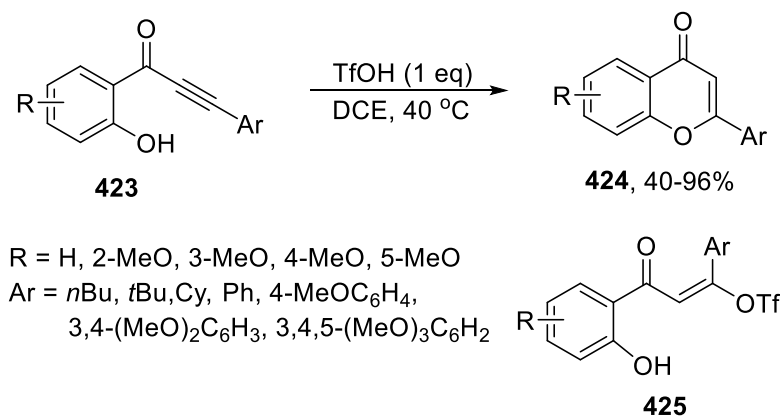

Triflic acid was also employed by Taylor and Bolshan to synthesize 5-methoxyflavones.¹²⁵ The methoxy group did not react under these conditions, which is interesting considering the reactivity exhibited by 1-(2-methylchalcogenophenyl)prop-2-yn-1-ones (Section 3.1.3.3.3).³⁹²

Intramolecular acid-catalyzed conjugate addition of a hydroxy group to an ynone can lead to the formation of other products than vinyl ethers and ketals if a C-C double bond or an electron-rich aryl group is properly located elsewhere in the molecule. Fañanás and co-workers investigated a number of such compounds with the general structure **426**.³⁹³

When exposed to TfOH, HBF₄ or polystyrene-bound PTSA (PS-PTSA), a number of 9-oxabicyclo[3.3.1]nonenes **427** were obtained, in particularly high yield when PS-PTSA was employed. A reasonable mechanistic proposal has been presented and some of the intermediates (**I-IV**) are shown in Scheme 191.³⁹³ The yield was also excellent when two 3-methoxybenzyl groups were attached to C7 in ynone **426**, as it is depicted in the Scheme 191 for compound **428** and the product **429**.

Scheme 191. Formation of 9-Oxabicyclo[3.3.3]nonenes **427 and **429** by Acid-Catalyzed Double Intramolecular Michael Addition to Yrones **426** and **428****

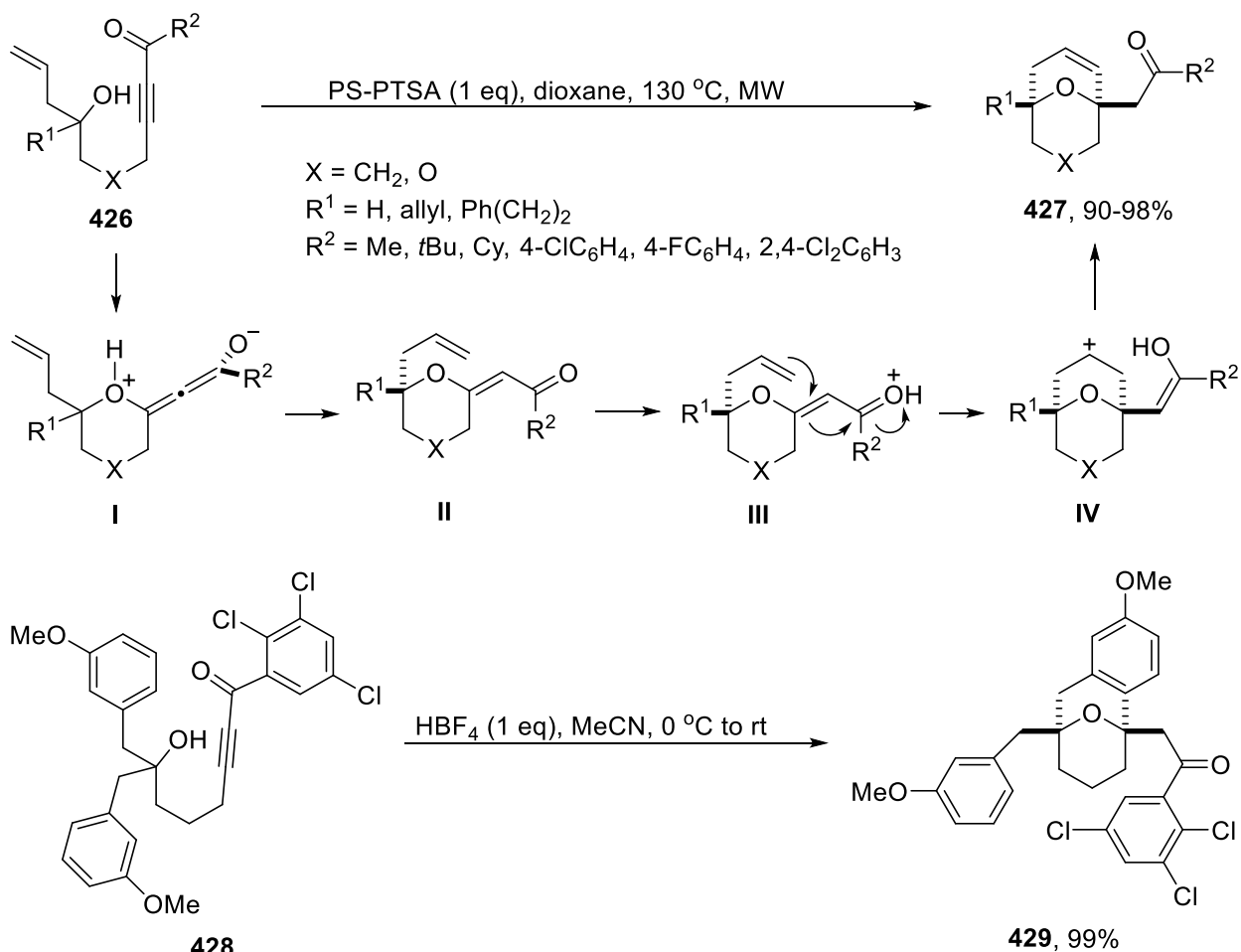

Conjugate addition of a benzylic alcohol generated in the proximity of an ynone during a reaction was observed by Sydnes and co-workers in their study of chemical properties of quinoxaline derivatives.³⁹⁴ When some 3-(1-aryl-4,4,5,5-tetraethoxy-1-hydroxypent-2-ynyl)quinoxaline-2(1*H*)-ones (**430**) were subjected to PTSA in refluxing aqueous THF, deacetalization and enolization generated intermediate **431** which cyclized in a 5-*exo-dig* fashion and gave consistently two products, the expected furo[2,3-*b*]quinoxaline **432** and its isomer **433** in a ratio of about 2.5:1 and a total yield better than 75% (Scheme 192).

Scheme 192. Formation of Furoquinoxalines **432 and **433** from Quinoxalinones **430** by Intramolecular Cyclization**

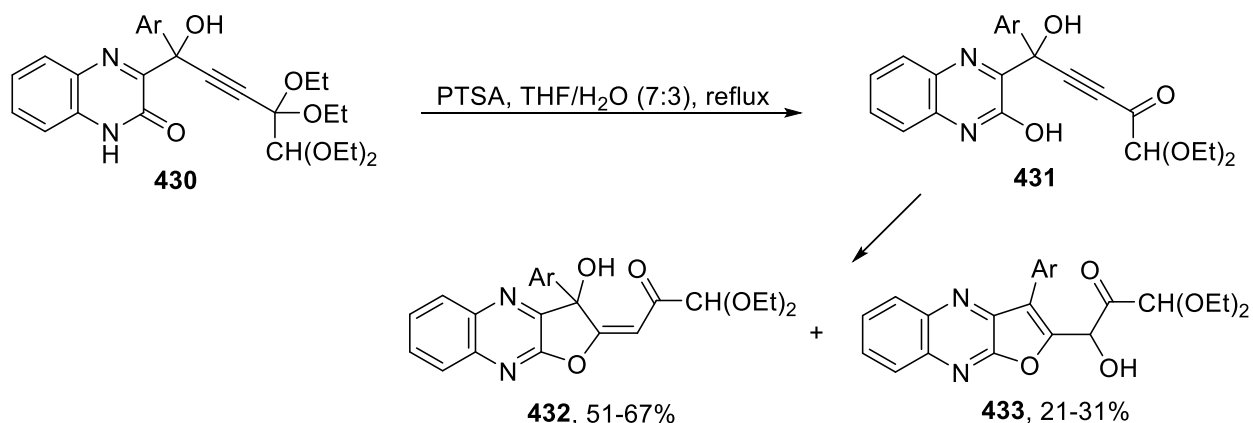

Ar = Ph, 3-MeC₆H₄, 4-MeC₆H₄, 3-ClC₆H₄, 4-ClC₆H₄, 3-O₂NC₆H₄

In conclusion, intramolecular alcohol addition to ynones under acidic conditions is most frequently catalyzed by *p*-toluenesulfonic acid. When possible from a structural point of view, diaddition with acetal formation occurs with retention of the alcohol configuration. The yield is usually good to excellent. Phenols react with monoaddition and flavone formation. If the substrate contains an olefinic moiety, more elaborate reactions have been reported.

Activation by Bases. Intramolecular conjugate addition of alcohols to ynones has been achieved under a variety of basic conditions. The mildest and simplest reaction consists of stirring the substrate in a solvent in the presence of Et₂NH. This reaction has been applied to fuse a 4-pyranone to an aromatic core with an OH group attached *ortho* to the carbonyl group in the ynone moiety. The reaction starts with hydroamination of the ynone **65**, followed by oxygen attack of the resulting enaminone (**434**), and is completed by expulsion of diethylamine. Brimble and co-workers used this approach in their studies of syntheses of rubromycins (**435**),⁶⁶ and so did Suzuki and colleagues in their successful total synthesis of γ -indomycinone in nine steps from juglone involving compounds **436-438** (Scheme 193).³⁵¹

Scheme 193. Diethylamine-Promoted Intramolecular Cyclization of Ynone 65 and 436

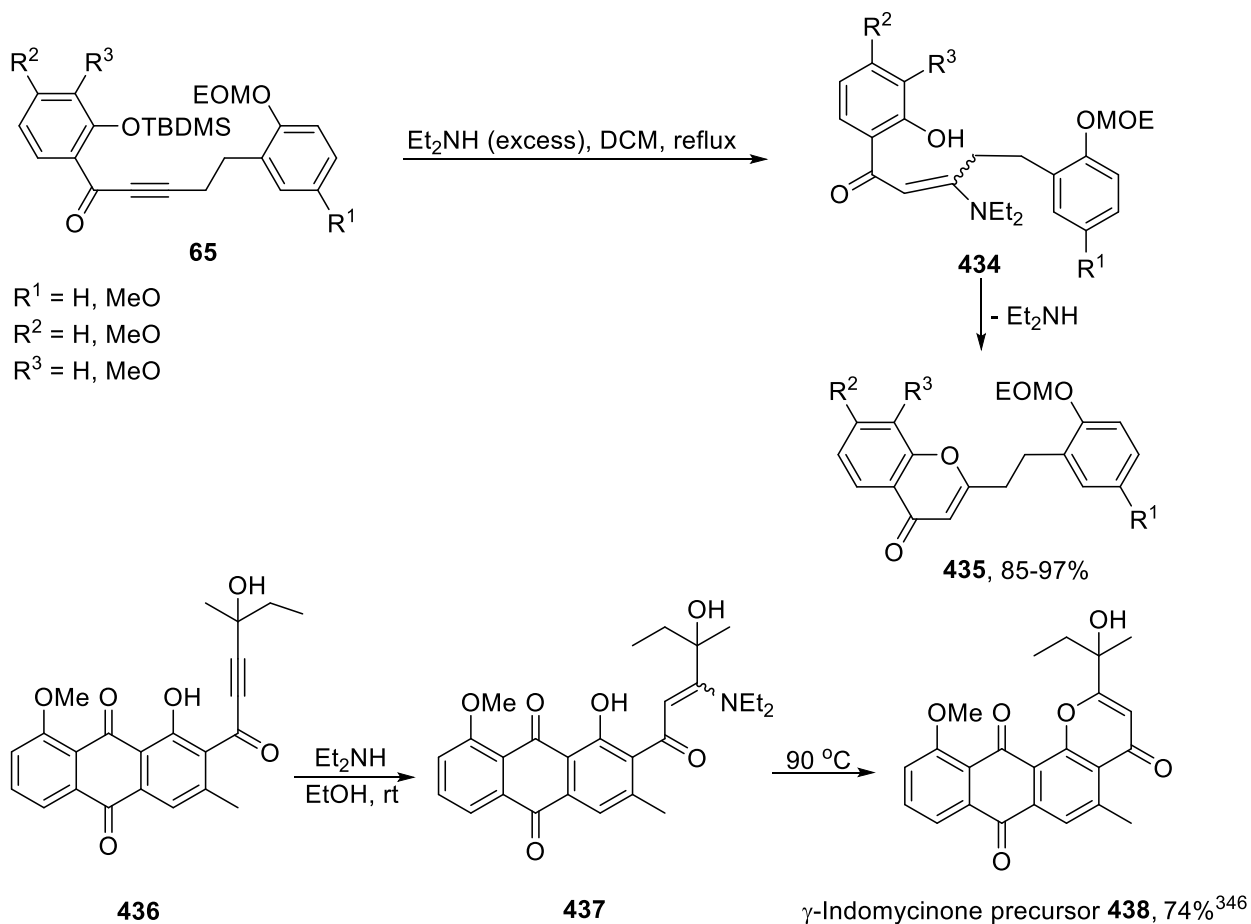

DMAP was used by Castillo-Contreras and Dake to activate the OH group in phenol **439** for conjugate addition to the ynone unit.³⁴ With three carbon atoms between the aldehyde group and the β carbon in the triple bond, the vinylic carbanion formed when the Michael addition took place would react with the formyl group and form another 6-membered ring. This tandem process afforded tetrahydroxanthone derivatives **440** in fair yields along with small amounts of flavones **441** (Scheme 194).³⁴

Scheme 194. Synthesis of Tetrahydroxanthones 440 from Ynone 439

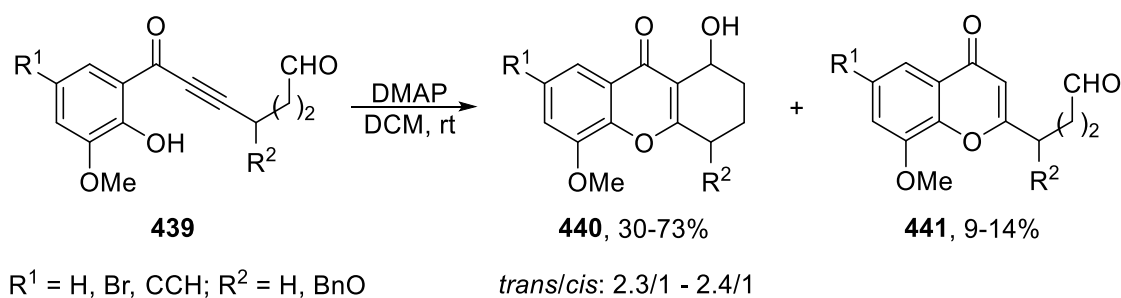

Basic activation was also applied by Rager and co-workers in the preparation of 2-ferrocenylchromen-4-ones (**443**) starting from ferrocenyl ynones **442** (Scheme 195).³⁹⁵

Scheme 195. Synthesis of Chromen-4-ones 443 from Ynones 442

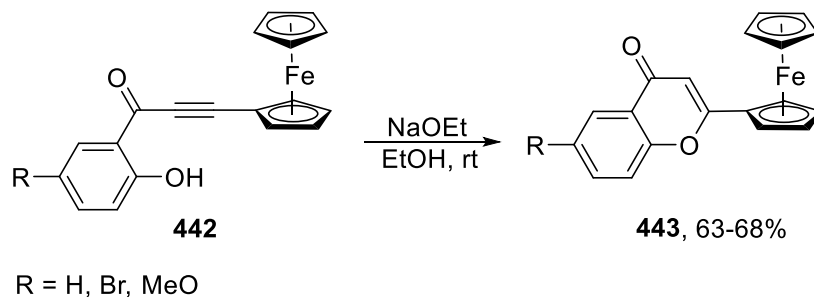

Kishi and co-workers, in their study of the total synthesis of halichondrin C, deprotected silyloxy moieties under basic conditions to facilitate the intramolecular conjugate addition of alcohols to the ynone unit.³⁹⁶ A model study showed that the outcome was dependent on the method applied to carry out the deprotection. When triple Si-protected trihydroxy ynone **444** was allowed to react during the treatment with HF followed by DBU, intramolecular diaddition took place via enone **445** giving the acetal **446**. These conditions were then applied in the synthesis of the right half of polyether halichondrin C (**448**) (Scheme 196). The ynone precursor (**447**) was prepared by DMP oxidation of the corresponding propargylic alcohol in 94% yield.

Scheme 196. Acetal Formation in a Model Compound 446 and the Right Half 448 of Halichondrin C by Conjugate Addition of a Diol to an Ynone moiety

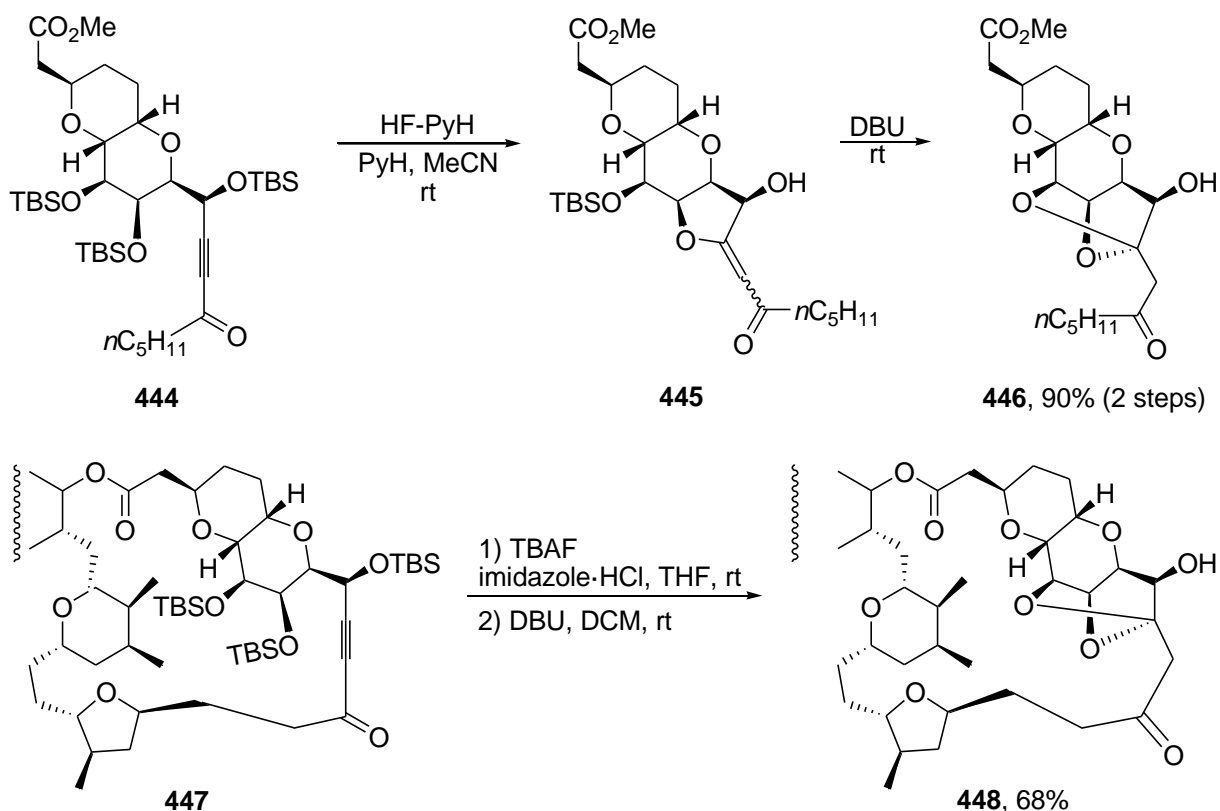

Enolates are *C,O*-1,3-dinucleophiles, and although reactions at carbon predominates, *O*- versus *C*-alkylation is occasionally an issue to keep in mind when enolate chemistry is applied. This was the case when Huang and co-workers reported that the enolate from some alkyl 2-arylethynyl ketones **71** reacted with a large variety of α -cyano- α,β -unsaturated enones **449** and the enolates thus formed reacted with the ynone moiety in a Michael fashion with the oxygen nucleophile (Scheme 197).³⁹⁷ This domino process, formally a [4+4] cycloaddition, afforded eight-membered cyclic ethers **450**. Optimization studies revealed that the best base to apply was 1,4-diazabicyclo[2.2.2]-octane (DABCO) whereas the best solvent was a mixture of ethylene glycol and toluene. Two plausible mechanisms for the stepwise cyclization have been suggested.

Scheme 197. DABCO-Mediated [4+4] Domino Annulation of Ynones **71** and α -Cyano- α,β -Unsaturated Enones **449**

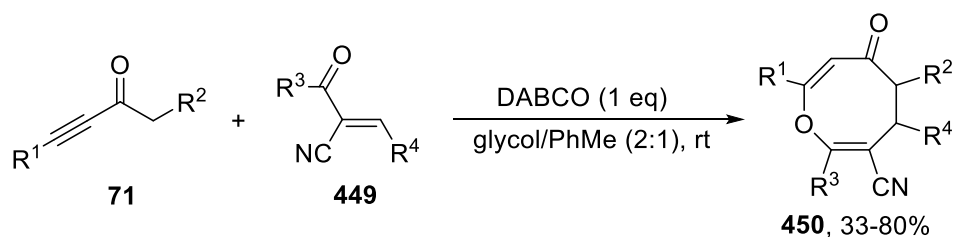

R^1 = Ph, 4-MeC₆H₄, 4-FC₆H₄; R^2 = H, Me, Me₂; R^3 = Ph, 4-MeC₆H₄, 4-BrC₆H₄
 R^4 = Ph, 2-MeC₆H₄, 3-MeC₆H₄, 4-MeC₆H₄, 4-FC₆H₄, 4-ClC₆H₄, 2-BrC₆H₄, 3-BrC₆H₄,
 4-BrC₆H₄, 4-MeOC₆H₄, 4-F₃CC₆H₄, 2,4-Cl₂C₆H₃, 1-naphthyl, 2-naphthyl, Cy

An enolate eventually attacking an ynone intramolecularly as an alkoxide was observed by Deng and co-workers when a variety of 2-diazo-3,5-dioxo-6-ynones (**451**) were treated with various weak basis.³⁹⁸ Under optimum conditions a clean reaction took place and pyrano[3,2-*c*]pyrazol-7(1*H*)-ones (**452**) were obtained in high yield (Scheme 198). A mechanism for the reaction shows that a key element is the ability the diazo group has to engage in a 6- π electrocyclic ring closure of intermediate **I**, which in this case leads to formation of a pyrazole and an alkoxide **II** that attacks the ynone in a Michael fashion to give **III**, precursor of the product (**452**) through its tautomer **453**.³⁹⁸

Scheme 198. Et₃N-Promoted Cyclization of Ynones 451 to Pyranopyrazolones 452

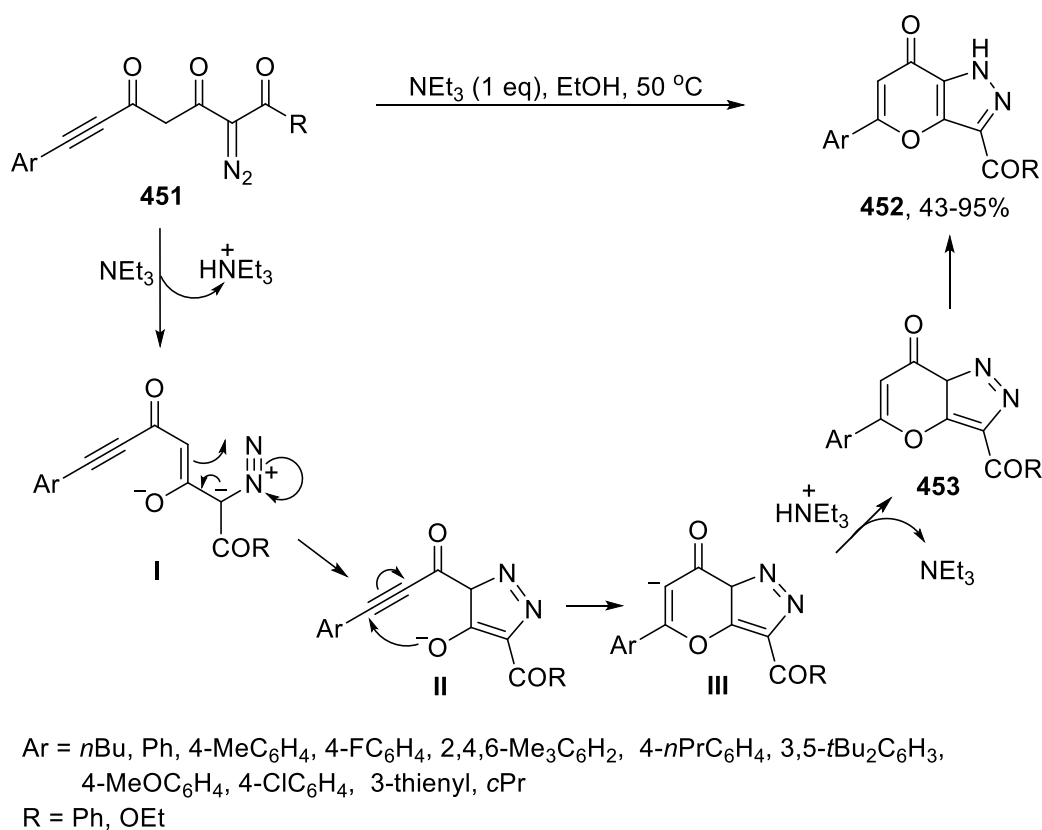

Conjugate addition of a phenol generated in the proximity of an ynone motif during a reaction has been observed in a few cases. In studies of xanthofulvin and vinaxanthone syntheses, Siegel and co-workers benefitted from such a transformation in the conversion of flavones **454** to xanthenes **455** (Scheme 199).³⁹⁹ The crucial stage in this multistep transformation is a 6-*exo-dig* attack of an ynone moiety by the phenol in **457** generated after the initial attack of **454** by methyl acetoacetate (MAA) enolate giving intermediate **456**. After tautomerization, the resulting compound (**458**) gave ester **459**, but this compound does not survive the rather basic conditions and undergoes an aldol-type condensation to provide the final product **455**. This (at least) six-step one-pot reaction is a high-yield process; for instance, when R = *tert*-butyl, R¹ = pivaloyl (Piv) and R² = methoxymethyl (MOM) the overall yield is 83%.³⁹⁹ The same rearrangement can be

performed by treating flavones with Et₃N in aqueous MeCN at room temperature, there are two significant differences: 1) due to the mild basic conditions, the reaction can be stopped before the condensation takes place, and 2) since there is no substituent attached to the flavone C-2 carbon, a formyl group and not a long carbon chain will be attached to C-3 in the final product (**460**) (Scheme 199). Siegel and co-workers took advantage of these differences and succeeded in performing Diels-Alder reactions with a number of conjugated ynone (Section 3.2.3). Compound **455** has been used for the synthesis of xanthofulvin,⁴⁰⁰ one of the most promising leads in the development of treatments for spinal cord injury.

Scheme 199. Conversion of Flavone 454 to Xanthone 455

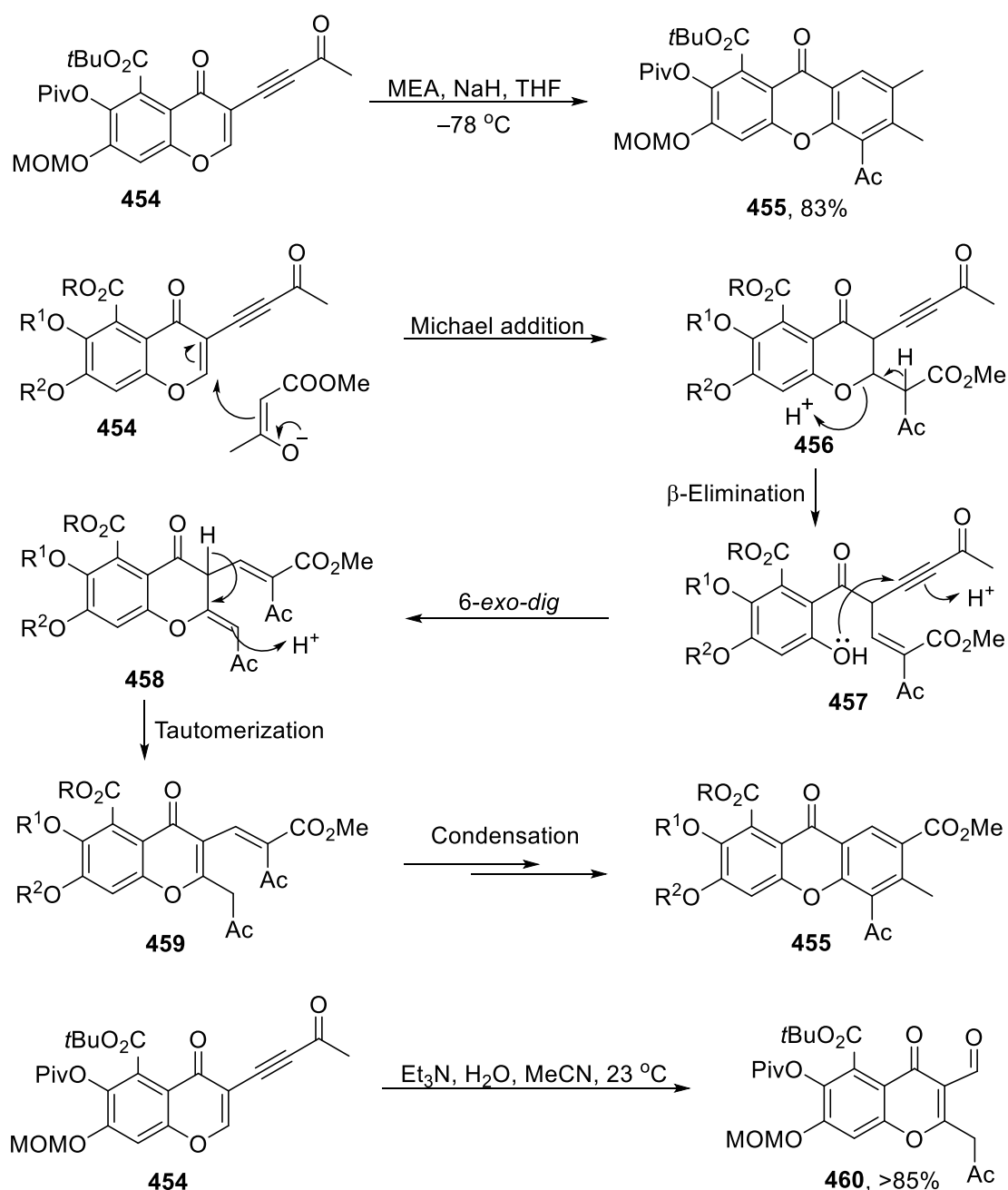

Activation by Silver Salts. Intramolecular monoconjugate addition of alcohols to ynones has also been achieved with a number of β' -hydroxy α,β -unsaturated ynones by addition of a Ag(I)-salt, which functions as a catalyst by forming a complex with the triple bond and render the β -carbon in particular more electrophilic. All reactions reported have been carried out in essentially the same way using silver triflate in DCM, either at room temperature or 100 °C, with a reaction time up to a few hours, and without exceptions, the products formed are 2,3-dihydro-4*H*-pyran-4-one derivatives, which are frequently isolated in excellent yield (even when the substrate also contains other oxygen atoms that conceivably could influence the outcome of the reaction through complexation or hydrogen bonding).^{67,98,99,169,170,401}

It is noteworthy that the cyclization occurs with retention of configuration at the hydroxylated carbon atom which becomes a member of the 2,3-dihydropyranone formed during the conjugate addition. Thus, the ee of the heterocycle is essentially identical to that of the substrate, the β' -hydroxy α,β -unsaturated ynone **461**, and Shibasaki and co-workers therefore opted for introducing the hydroxylated stereocenter by a Cu(I)-catalyzed enantioselective aldol reaction [using (*R*)-DTBM-SegPhos as chiral ligand] in the last step before cyclization by conjugate addition catalyzed by AgOTf to yield chiral pyranone **462**. Under the optimized reaction conditions ee was in the 75-93% range, even when the acetylenic ketone changed from a methyl to an ethyl ketone (Scheme 200).⁴⁰¹

Scheme 200. Ag-Catalyzed Intramolecular Cyclization of Ynone 461 to Give Dihydropyranone 462

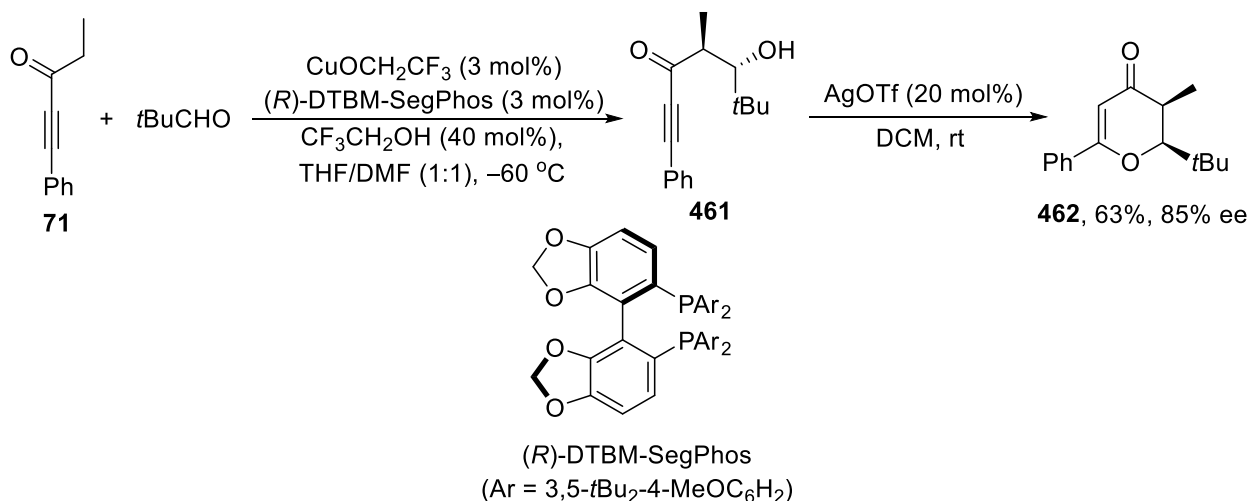

Some applications of AgOTf-catalyzed intramolecular conjugate addition of alcohols to ynones in the preparation of natural products illustrate the usefulness of this transformation in organic synthesis. Thus, Fuwa and co-workers used the method to prepare the AB-ring fragment **464** of the very complex marine polycyclic ether gambierol from ynone **463**, but it is interesting to note that the yield became excellent only after it

was discovered that improvements were made by adding 2,6-di-*tert*-butylpyridine (DTBP) (Scheme 201).⁶⁷ The same reaction is the most striking feature in the enantioselective synthesis of a fragment **465** of diospongin A from L-malic acid derived ynone **103**, published by Reddy and co-workers (Scheme 201).⁹⁹

Scheme 201. AgOTf-Catalyzed Intramolecular Conjugate Addition of an Alcohol to an Ynone in Compounds 463 and 103 in Natural Product Syntheses

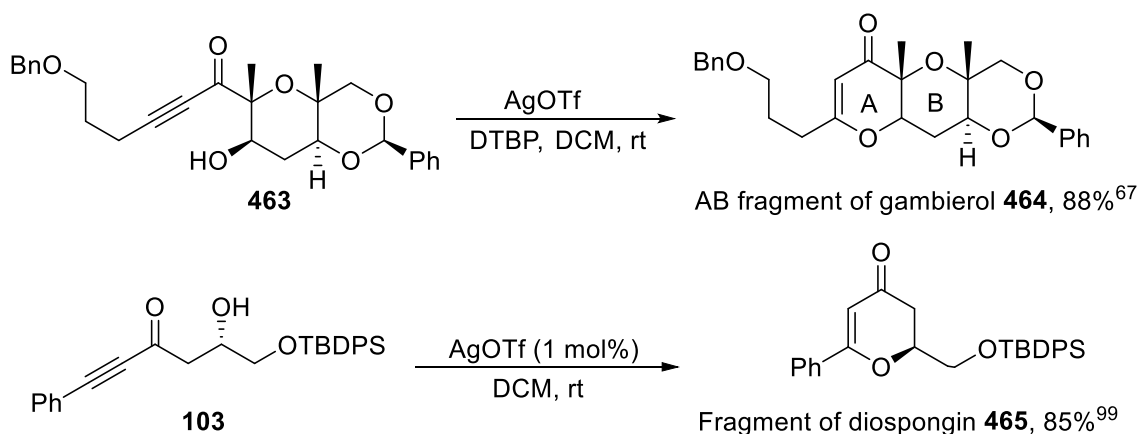

Silver-catalyzed attack by a keto oxygen atom is involved when cyclization of 2-diazo-6-ynones **451** leads to the formation of γ -pyrones **466**. A key element is enolization of the keto moiety at C-3 which renders its oxygen atom more prone to attack the β -carbon in the triple bond. As reported by Deng and co-workers, the success of the reaction is critically dependent on the reaction conditions, in particular the nature of the silver salt.⁴⁰² Of a very large number of catalysts tested, AgSbF₆ in methanol turned out to be the best choice to achieve predominantly a Michael addition and form **466**, but a small amount (< 6%) of (2*H*)-furan-3-one **467** was formed in most cases. On an average, the total yield of the two heterocycles was 96% with a pyrone/furanone ratio of 98:2 (Scheme 202).⁴⁰² Using AgOAc instead of AgSbF₆ changed the outcome completely.

Scheme 202. AgSbF₆-Catalyzed Pyrone 466 Formation from Diazoynones 451

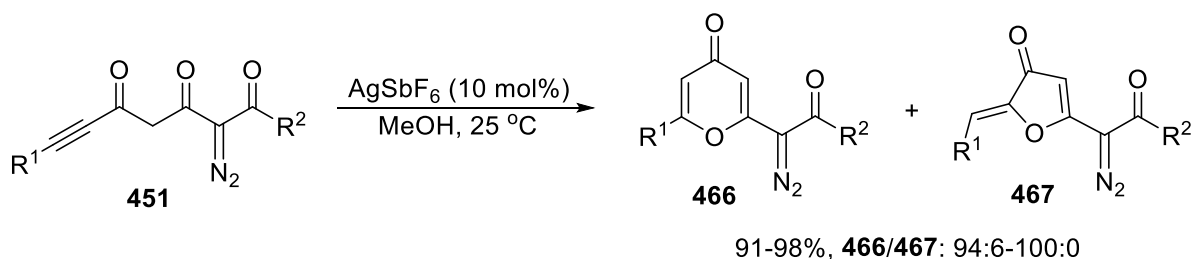

R¹ = Ph, 4-MeC₆H₄, 4-*n*PrC₆H₄, 3,5-*t*Bu₂C₆H₄, 4-MeOC₆H₄, 4-ClC₆H₄, 4-FC₆H₄, (*E*)-PhCH=CH, Me₂C=CH, (*E*)-Me(CH₂)₆CH=CH, 3-thienyl, *c*Pr, *n*Bu, Me₃Si
 R² = Ph, OEt, benzylcarbamate

In conclusion, AgOTf is a particularly excellent catalyst for intramolecular Michael addition of a β' -C hydroxyl group to an α,β -ynone, giving 2,3-dihydropyran-4-ones in

very good yields. It is noteworthy that the reaction takes place with retention of the alcohol configuration.

Activation by Other Metal Salts. Conjugate addition of alcohols to ynones has basically been performed with relatively nucleophilic alcohols, so if less reactive alcohols were going to react, more powerful catalysts should most likely have to be applied. Gouverneur and co-workers argued along in this line and set out to test this theory by investigating the 6-*endo-dig* cyclization for deactivated β' -hydroxy α,β -ynones **468**. Deactivation was attempted by replacing the methylene group between the carbonyl and hydroxyl groups with a difluoromethylene motif. The outcome was as anticipated, cyclization did not proceed under acidic or basic conditions or by using any of the silver salts usually employed, but when 5 mol% AuCl in CH₂Cl₂ was applied the corresponding 2,3-dihydropyran-4-one **469** was obtained in almost quantitative yield (Scheme 203). No traces of products from the competing 5-*exo-dig* ring closure or any other reactions were observed, and a number of structural variations were tolerated.⁴⁰³ The reaction was then further expanded by running the reaction in the presence of *N*-halosuccinimides (halo = chloro, bromo, iodo) that can capture the postulated vinyl gold intermediate and the corresponding 5-halo-2,3-dihydropyran-4-ones **470** were furnished with both NBS (70% and 82% yield) and NIS (65-92% yield) (Scheme 203).⁴⁰³ Alkoxychlorination with NCS was unsuccessful. Alkoxyfluorination, however, was achieved with several fluorinating agents, but even when the most successful (Selectfluor) was used, the yields of trifluoro-2,3-pyran-4-ones **471** were low because the proposed vinyl-gold intermediate suffered protodeauration to a considerable extent and gave pyranones **472** (Scheme 204). Finally, it should be mentioned that if alkoxyfluorination is performed with Selectfluor under aqueous conditions, the primary product reacts quickly and suffers hydroxyfluorination and furnishes 3,3-difluorotetrahydropyran-4-one **473** and also by-products **474** in variable yields (Scheme 204).⁴⁰³

Scheme 203. Au(I)-Catalyzed Intramolecular Cyclization of Hydroxy Ynones 468

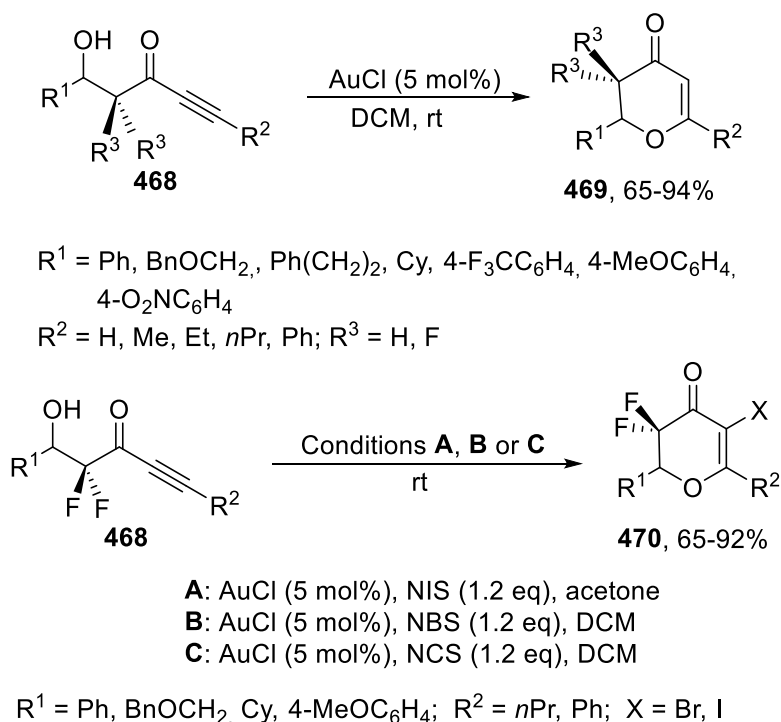

Scheme 204. Au(I)-Catalyzed Alkoxyfluorination of β -Hydroxy Yrones **468**

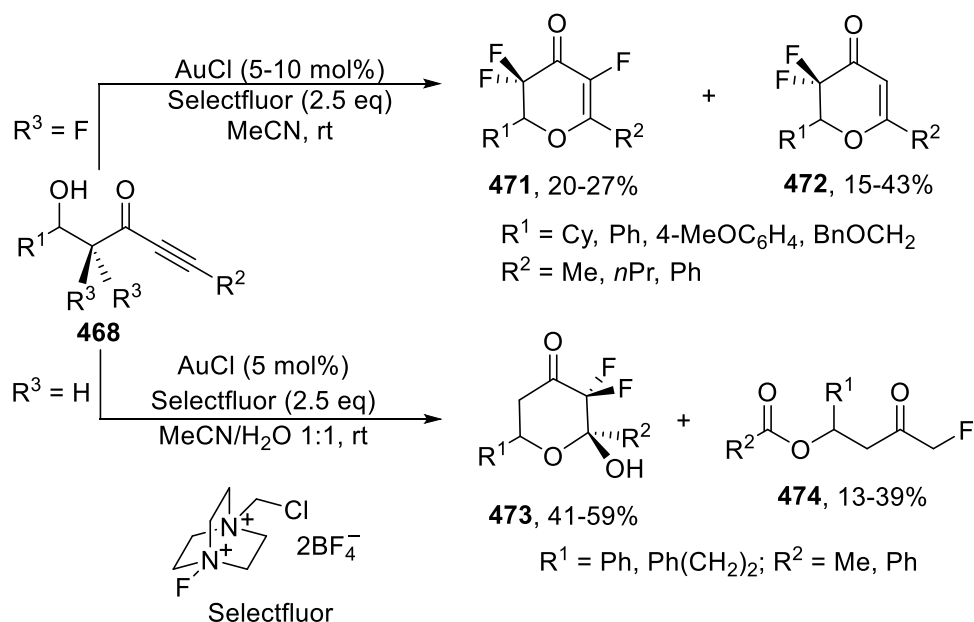

Gouverneur and co-workers have also performed catalyzed domino Wacker-Heck reactions with β' -hydroxy- α,β -unsaturated yrones **468** using ethyl acrylate as the trapping agent.⁴⁰⁴ A large number of catalyst systems were tested but even with the best alternative (a Pd(II) complex with Cu(II) as a co-oxidant) the final products, ethyl (3,4-dihydro-2*H*-pyran-5-yl)acrylates **475**, were obtained in medium yield only (Scheme 205). A plausible mechanism is outlined in Scheme. First, intramolecular oxypalladation of the

hydroxy ynone takes place, conceivably facilitated by initial coordination of Pd(II) to the triple bond (**I** to **II**). Then the resulting σ -alkenyl palladium(II) undergoes carbopalladation of ethyl acrylate to give **IV** through complex **III**. Finally, **475** is formed by β -elimination of a palladium hydride species which re-enters the catalytic cycle after oxidation with molecular oxygen. It is noteworthy that the Wacker-Heck process took place with no detectable racemization of any chiral center. Finally, it is of interest that α' -hydroxy ynones **476**, with an alkyl or an aryl group on the triple bond, react similar to the β' analogues and give the corresponding furanones **477** in 52-65% yield (Scheme 206).⁴⁰⁴

Scheme 205. Wacker-Heck Oxidative Heterocyclization of β' -Hydroxy Ynones **468**

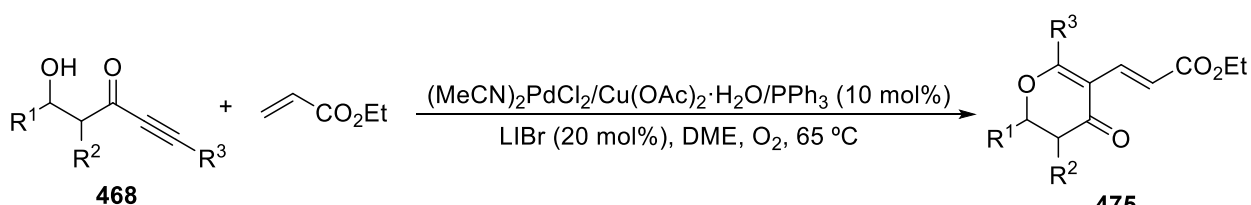

R¹ = Ph, 4-MeOC₆H₄, 4-O₂NC₆H₄, Ph(CH₂)₂
 R² = H, Me; R¹-R² = (CH)₄; R³ = Me, Et, Ph

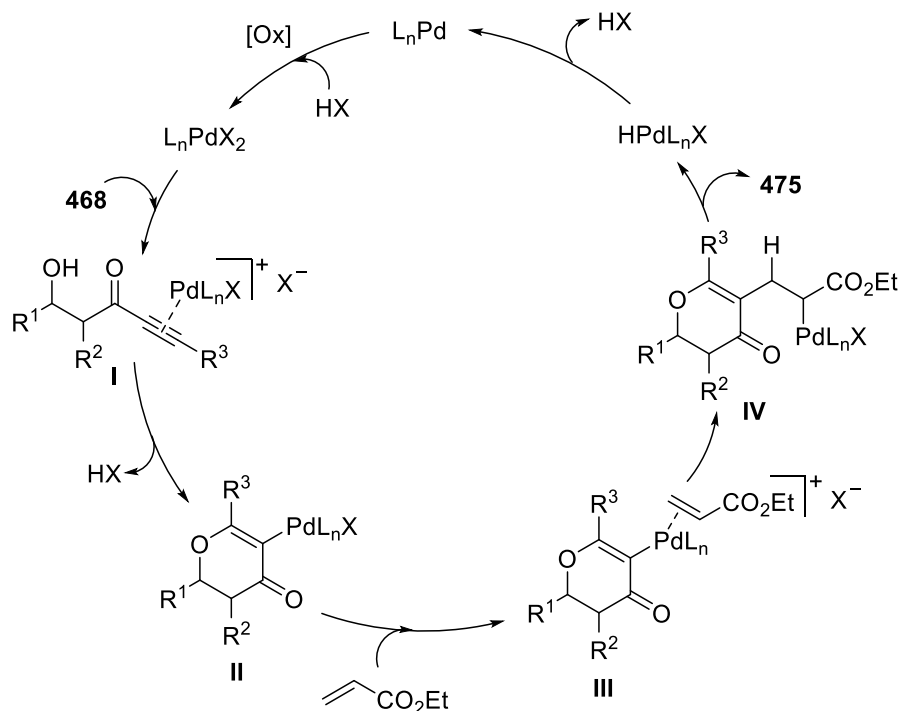

Scheme 207. Pd-Catalyzed Cascade Wacker/Allylation Sequence of Hydroxy Ynonones 468 with Allylic Alcohols

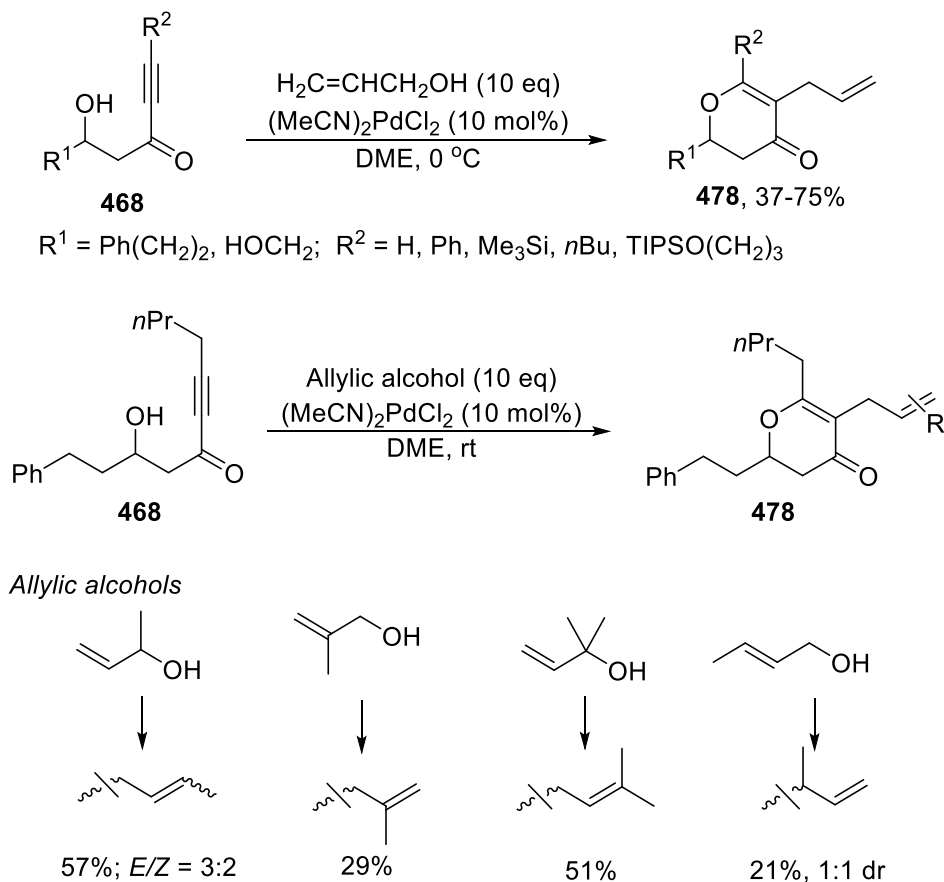

Gold(I) catalysts have also been used to convert *tert*-butyl and trimethylsilylethyl 3-oxoalk-4-ynoates **479** into the corresponding 4-hydroxy-2-pyrones **480**.⁴⁰⁶ With [(SPhos)AuNTf₂] as catalyst, the reaction proceeded cleanly, scaled well, tolerated various substituents, and afforded **480** in excellent yield almost without exception (Scheme 208). The activation is due to π complexation of Au(I) to the triple bond, which facilitates formation of vinylgold intermediates **I** and **II** that undergo protodeauration and formation of the final products.

Scheme 208. Au(I)-Catalyzed Intramolecular Cyclization of Ynonones 479

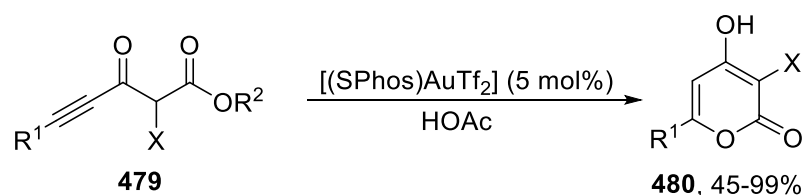

$\text{R}^1 = \text{Me, Et, Ph, TMS, } n\text{Pent, (1R)-THPO(CH}_2)_3\text{CHMe}$

$\text{R}^2 = t\text{Bu, TMS(CH}_2)_2; \text{X} = \text{H, Me, F, Br}$

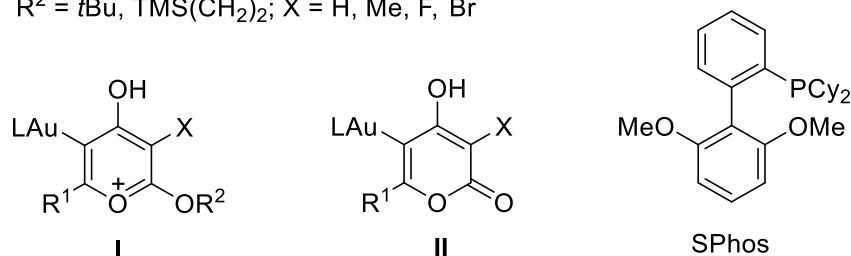

Activation by Iodonium. Activation by I^+ was utilized by Likhar and co-workers to convert some 3-substituted 1-(2-methoxyphenyl)prop-2-yn-1-ones **481** to the corresponding 3-iodochromenones **482** (Scheme 209).¹⁷⁹ The iodonium ion was generated from iodine by means of cerium ammonium nitrate (CAN), which also facilitates the conversion of the anisole motif to the corresponding phenol that then reacts with the iodonium-activated triple bond.

Scheme 209. Iodonium-Promoted Intramolecular Cyclization of Ynones **481**

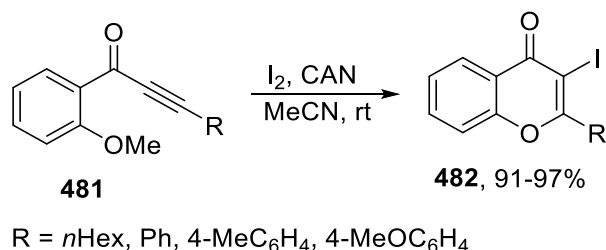

In conclusion, both Au(I) and Pd(II) compounds are good catalysts for intramolecular Michael addition of a β' -C hydroxyl group to an α,β -ynone. The resulting 2,3-dihydropyran-4-ones are formed in lower yields than in AgOTf-catalyzed reactions previously described, but the vinylgold and vinylpalladium intermediates formed have been utilized to attach substituents, such as halides, (*E*)-2-(ethoxycarbonyl)ethyl, and 2-alkenyl groups, to α -C in a secondary reaction, overall in moderate to good yields.

3.1.3.2.2. Intermolecular Reactions. Sydnes and co-workers studied the reaction of 1,1-diethoxybut-3-yn-2-one (**350**) with alcohols and alkoxides and the outcome appeared to be quite sensitive to the reaction conditions.^{349,350} In pure ethanol at room temperature no reaction occurred, but at reflux two products were obtained in moderate yields, (*E*)-1,1,4-triethoxybut-3-en-2-one (**483**) and 1,1,4,4-tetraethoxybutan-2-one (**484**) (Scheme 210). Addition of Et_3N improved the yield of both compounds, and when the reaction was performed with EtONa in EtOH , the protected ketodialdehyde was obtained in 66% yield.

Scheme 210. Ethanol Addition to 1,1-Diethoxybut-3-yn-2-one (350)

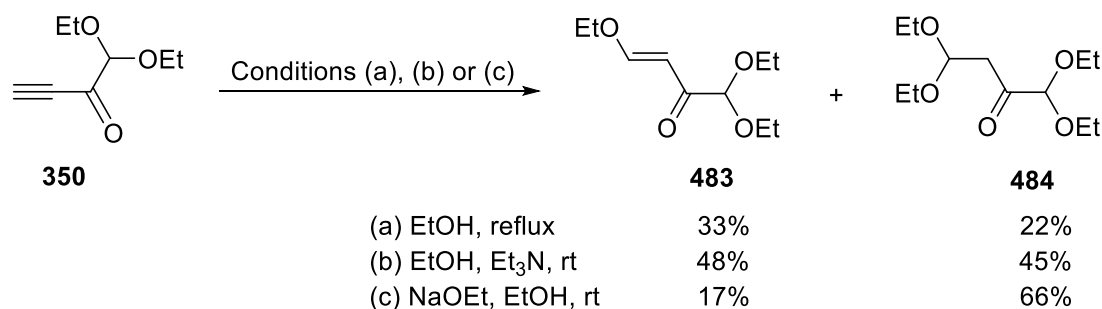

Monoaddition was the only reaction observed when Scheidt and co-workers carried out conjugate addition of benzyl alcohol to 1-phenylnon-2-yn-1-one (**71**) under NHC catalysis.⁴⁰⁷ The resulting conjugated enone **485** was isolated in good yield with excellent stereoselectivity (Scheme 211).

Scheme 211. NHC-Catalyzed Addition of Benzyl Alcohol to Ynone 71

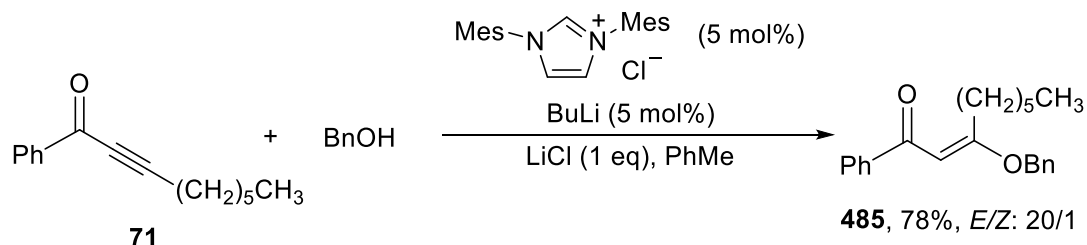

Monoaddition of methanol was also observed by Georg and co-workers when derivatives of 1-(2-aminophenyl)-3-arylprop-2-yn-1-one (**486**) were reacted with methanol at room temperature.⁹⁵ The products, chalcones **487**, were obtained as single isomers with *Z* configuration, but when heated to 45-50 °C, cyclization occurred and the corresponding quinolones **488** were obtained (Scheme 212). Bisaddition was not observed, probably due to steric hindrance.⁹⁵

Scheme 212. Conjugate Addition of Methanol to Ynone 486 and Further Cyclization to Quinolones 488

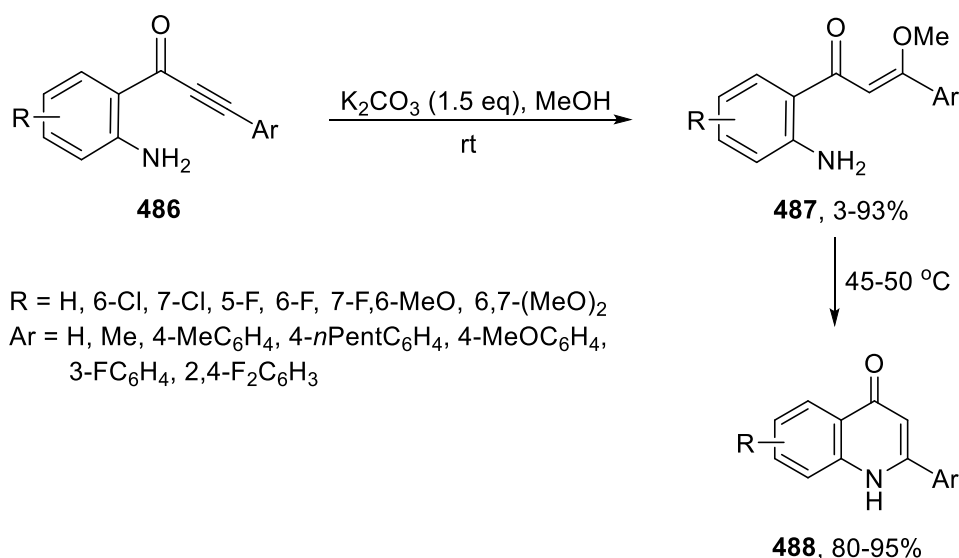

Marinelli and co-workers used alkoxides and a phenoxide to perform conjugate addition with some 3-(2-amino-5-methylpyridin-3-yl)-1-arylprop-2-yn-1-one (**331**).²⁴⁴ The expected products **489** were formed in good yields, but they suffered cyclization and afforded [1,8]naphthyridines **490** when the keto moiety was attacked intramolecularly by the NH₂ group (Scheme 213). The same secondary reaction occurred when **331** was reacted with thiolates and amines.

Scheme 213. Conjugate Addition of Alkoxides and a Phenoxide to Ynone 331 and *in situ* Cyclization to [1,8]Naphthyridines 490

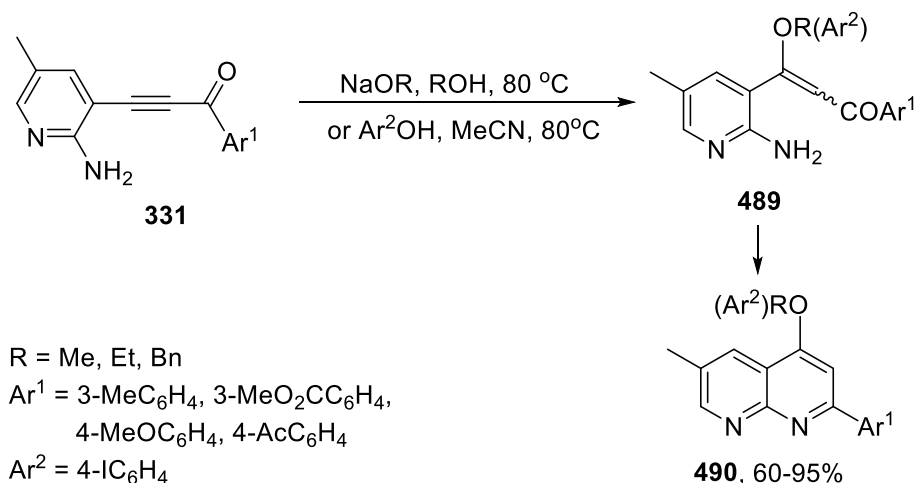

Some attempts to add water to ynone have been reported, but the expected 1,3-diketones have not been isolated. When 1,1-diethoxybut-3-yn-2-one (**350**) was reacted under standard conditions (NaOH, H₂O, THF), decomposition occurred and 2,2-diethoxyacetic acid was obtained in 86% yield.^{349,350} Water addition to 3-(2-aminophenyl)-1-phenylprop-2-yn-1-one using NaOH in DMF/H₂O was attempted by Marinelli and co-workers, but the reaction took a different course and gave 4-dimethylamino-2-phenylquinoline instead, in 71% yield.³⁰ This outcome became possible

because DMF hydrolyzed and produced dimethylamine that reacted with the ynones and form enaminones (Section 3.1.3.1.2).

Conjugate addition of water to ynones was put forward by Meng and co-workers as a key step in an acid-mediated reaction of 2-(3-oxobut-1-ynyl)benzaldehydes (**392**) with arenesulfonic acids that gave easy access to variety of sulfonyl-substituted indanones **491** in good yields (Scheme 214).⁴⁰⁸ In the proposed reaction mechanism, protonation of the ynone to give **492** activates the ynone for water attack and formation of a diketoaldehyde **493**, from which **491** is formed by well-established reactions.

Scheme 214. Acid-Mediated Synthesis of 3-Sulfonyl Substituted Indan-1-ones 491 from Ynones 392

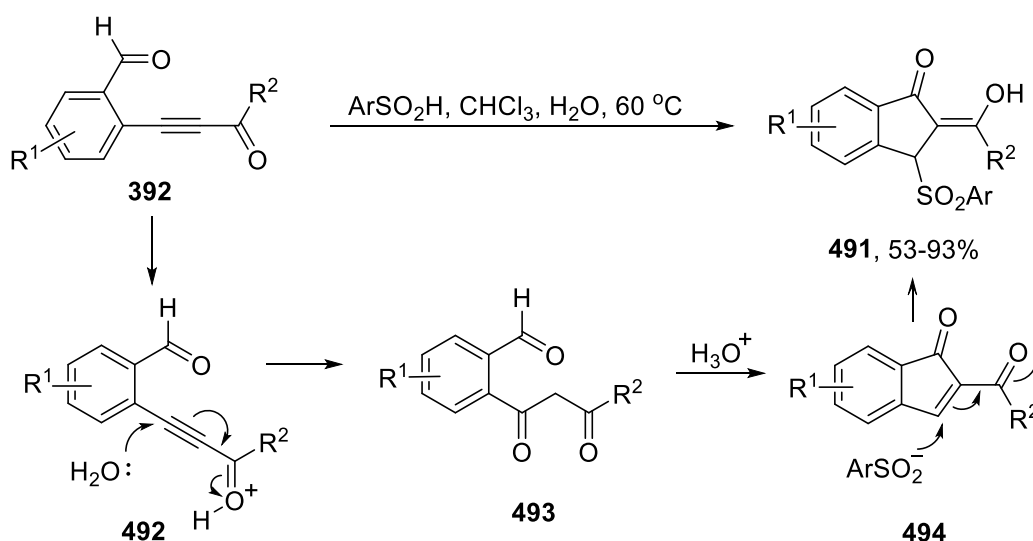

R¹ = H, 4-Cl, 4-F, 4-MeO, 5-Me, 5-F, 4,5-(MeO)₂

R² = Me, Ph

Ar = Ph, 4-MeOC₆H₄, 4-MeC₆H₄, 4-ClC₆H₄, 4-BrC₆H₄, 2-MeC₆H₄, 2-naphthyl, 2-thienyl

3.1.3.3. Other Nucleophiles. Nucleophiles centered at atoms beyond the second row in the periodic table have been applied much less frequently than carbon-, nitrogen- and oxygen-centered nucleophiles, but some applications have turned out to be quite useful. In reactions with a nucleophilic center at P, S, Se and halides, the movement of the electrons during the reaction is clear, but when metals are involved, such as Si and Sn, and the reaction is catalyzed by another metal, such as Pd, Mo and Rh, the electron mobility is more complex. However, whatever happens during the reaction, the metal attached to the carbon skeleton in the final product(s) acts as an electron-donating group and formally a nucleophilic contributor.

3.1.3.3.1. Silicon. Platinum-catalyzed hydrosilylation with R₃SiH is a well-established method for the synthesis of vinyl silanes from a range of alkynes. The best results have been achieved with terminal alkynes,⁴⁰⁹ but Rocke and Ferreira have shown that the method works well for internal ynones **71** as well.⁴¹⁰ All ynones were hydrosilylated in excellent yield and largely with excellent regio- and stereoselectivities

to give vinylsilanes **495** (Scheme 215).⁴¹⁰ The (*E*)-stereoselectivity (*E/Z* >19:1) is in keeping with *syn* attack of the triple bond as prescribed by the Chalk-Harrod mechanism for such reactions,⁴¹¹ whereas the preference for C- α silylation can be attributed to electronic effects.

Scheme 215. Pt-Catalyzed Hydrosilylation of Ynones **71**

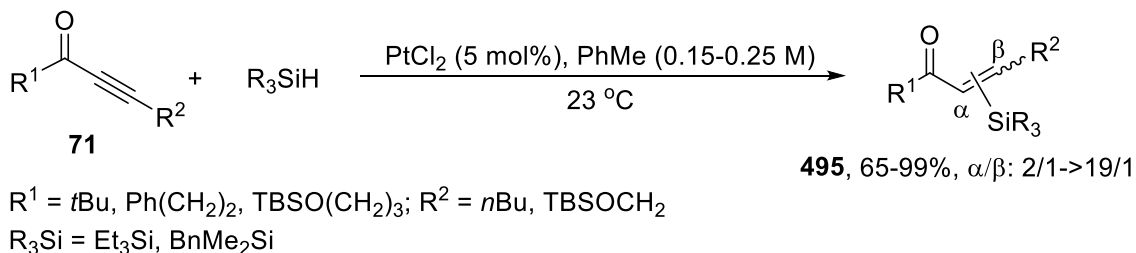

Ru-catalyzed hydrosilylation of ynones gives results similar to those obtained under Pt catalysis. By treating such ynones with R_3SiH in the presence of catalytic amounts of $[Cp^*Ru(MeCN)_3]PF_6$, Trost and Ball obtained excellent yields of the corresponding β -trialkylsilyl conjugated enone regioisomers **496** with *Z* configuration (due to exclusive *trans* addition to the triple bond) (Scheme 216).⁴¹¹ Trost and Bertogg later used the same reaction to prepare other silyl-substituted enones that were subsequently isomerized to 2,5-dihydro-1,2-oxasiloles.⁴¹²

Scheme 216. Ru-Catalyzed Hydrosilylation of Ynones **71**

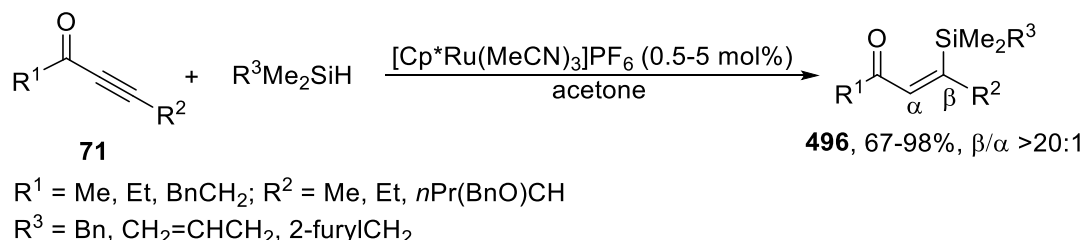

A complete change of regioselectivity was discovered by Lipshutz and co-workers when the silylating agent was changed from a hydride to Suginome's silylborane ($PhMe_2SiBpin$), the metal from $PtCl_2$ to $CuOAc/L$, and the solvent from dry toluene to water and an aqueous solution of the surfactant TPGS-750-M (**497**). Many alkynes with the triple bond conjugated to an electron-withdrawing group were investigated, and they all gave β -silylated conjugated olefins, in most cases in more than 80% yield.⁴¹³ All alkenes were formed as isomeric mixtures with an *E/Z* ratio better than 20:1, except for ynones **71**, which deviated significantly from each other. The most striking difference was that whereas the terminal alkyne 5-phenylpent-1-yn-3-one gave the corresponding alkene in modest yield with an *E/Z* ratio of >20:1, internal ynones 1-phenylundec-4-yn-3-one and 2-methyldec-5-yn-4-one afforded the olefins in high yield, but with a

considerable *Z* preference (Scheme 217). The reason for this is not clear. Deuteration experiments implied that the reaction involves an α -vinylcopper(I) species.⁴¹³

Scheme 217. Cu-Catalyzed Hydrosilylation of Yrones 71

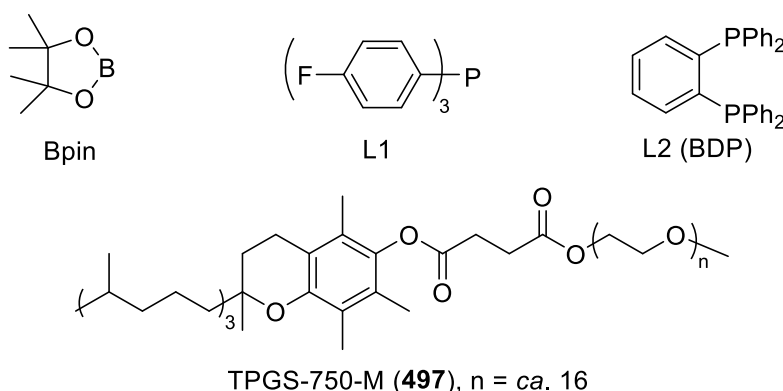
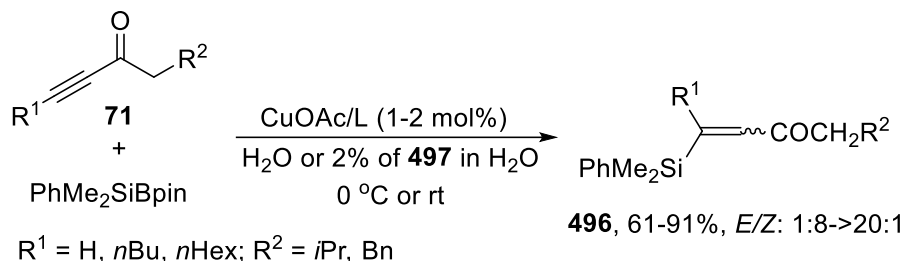

3.1.3.3.2. Phosphorous. A variety of conjugated yrones have been reacted with some P-centered nucleophiles, but unlike the N-centered nucleophiles, the phosphorous compounds are limited to triphenylphosphine and a few trialkylphosphines (PR_3). And just like trialkylamines, PR_3 is unable to undergo conjugate addition and the analogue reaction to hydroamination without some sort of rearrangement. Such rearrangements are considered in Section 3.5.3.

3.1.3.3.3. Sulfur, Selenium and Tellurium. Nucleophiles centered at S, Se and Te have been reacted with few yrones, and among these nucleophiles, the sulfur-centered have been used the most. The most common reaction involves thiolates generated *in situ* by adding a base to a solution of a thiol and yrones,^{46-48,414-416} but some reactions have also been carried out under neutral conditions.^{32,349,417} A few alkanethiols⁴¹⁵ and dithiols^{45-48,349,414-416} have been applied, but also some thiophenols.^{32,244,417} Furthermore, most reactions have been carried out at room temperature or below,^{45-47,414,416} but heating as high as 80 °C has also been reported.^{244,417}

The products obtained from conjugate addition of thiols to yrones depend on the number of thiol groups available per ynone moiety. When the ratio is close to 1:1, vinyl sulfides are generally formed in good to excellent yields as mixtures of isomers with an *E/Z* ratio that varies quite a lot,^{32,34,417} but when increased to 2:1 ratio, thioacetals are usually furnished in excellent yields.⁴¹⁵ Yrones **26**, **71** and **350** have been chosen to illustrate the synthesis of products **498-501** (Scheme 218).

Scheme 218. Michael Addition of Thiols to Selected Ynones 26, 71 and 350

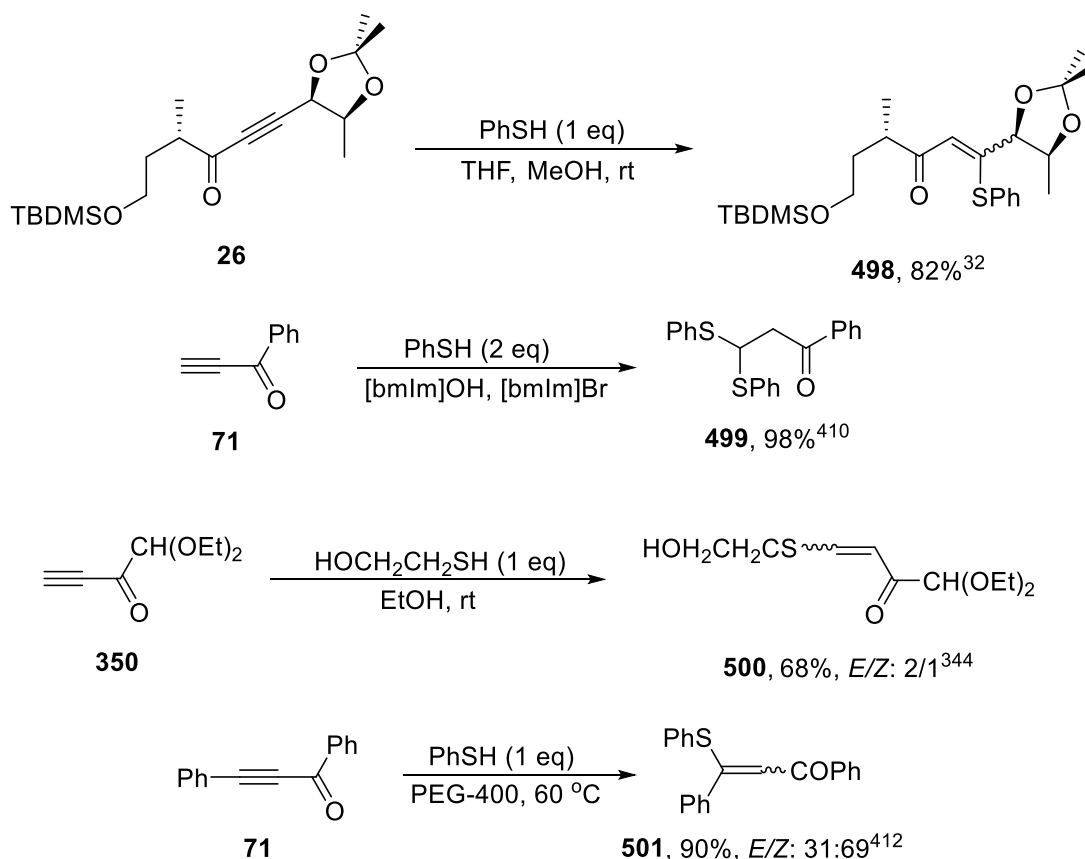

When ynones **71** are treated with propane-1,3-dithiol in a 1:1 molar ratio, the corresponding 1,3-dithiane was obtained. This reaction, developed by Ley and his group, is in general clean and gives the products (**502**) in excellent yields,^{45-47,414,416} but if the ynone contains a second electrophilic site, such as a formyl group (**503**), 1,3-dithiane formation may be followed by cyclization, which is the case when **503** is converted to spirocompound **504** (Scheme 219).⁴⁵

Scheme 219. Double Michael Addition of Propane-1,3-dithiol to Ynones 71 and 503

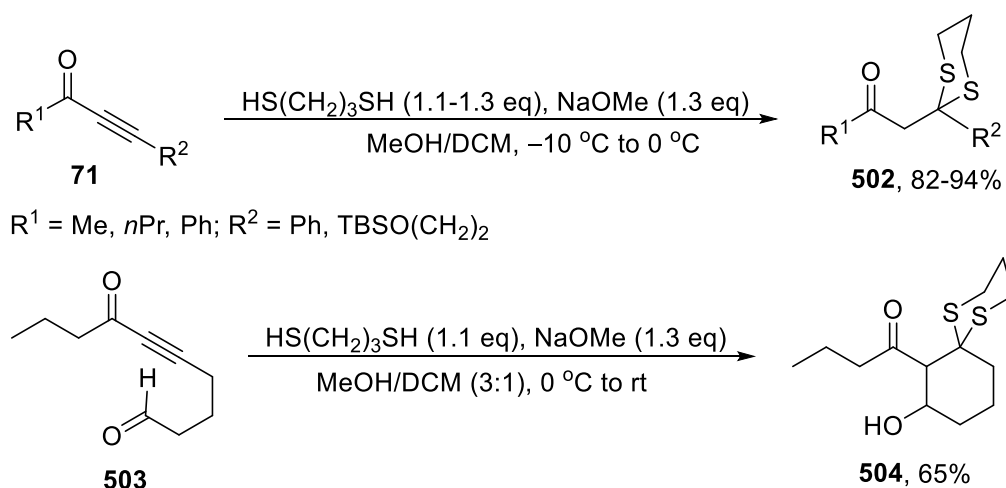

The transformation became a most valuable tool for Ley and co-workers who introduced keto functions in specific positions in key fragments of natural products,⁴⁵⁻⁴⁷ for instance, when ynones **505** were transformed into dithianes **506** in high yields as parts of syntheses of spongipyranes (Scheme 220). The reactions were also clean and efficient when applied to pent-1,4-diyne-3-one derivative (bis-ynone) **507** and gave the corresponding bis-dithiane ketone **508** in 80% yield (Scheme 220).⁴⁸

Scheme 220. Conjugate Addition of 1,3-Propanedithiol to Ynones 505 and 507

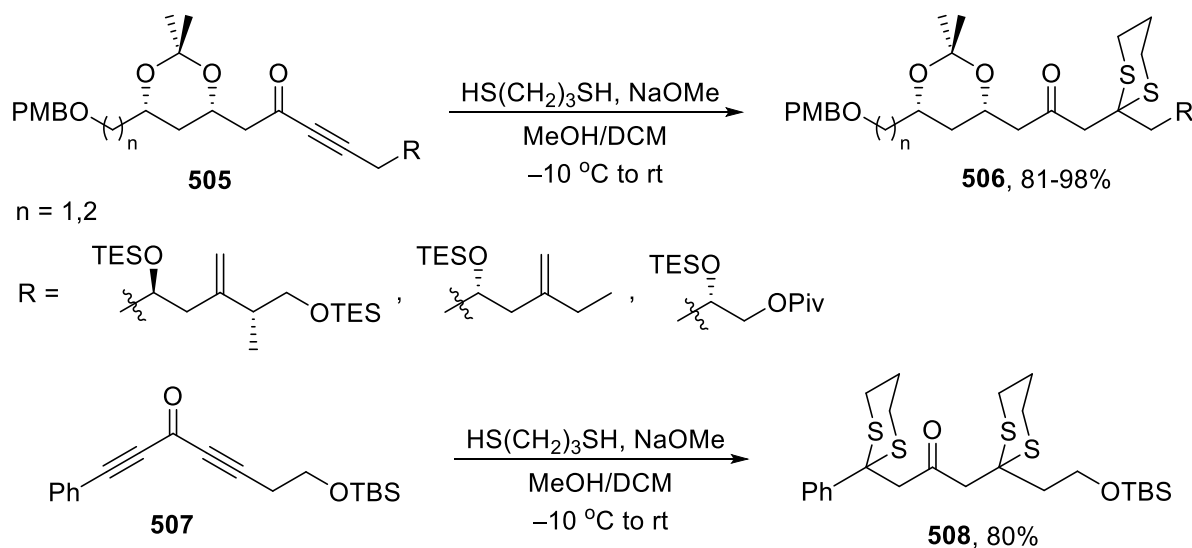

The efficient conversion of bis-ynones to β,β' -bis-1,3-dithiane ketones by conjugate addition of 1,3-propanedithiol has been used by Ley and co-workers to synthesize complex fragments of polyketide natural products. The preparation of two such fragments, the C₁-C₈ fragment of lyngbouilloside (**512**) and the C₁-C₈ fragment of callipeltoside A (**513**), are shown in Scheme 221 starting from ynones **48** and **509**, respectively, through bis-dithianes **510** and **511**, respectively.⁴⁸ It is noteworthy that **511**, the precursor to **513**, did not survive the reaction conditions applied to perform the conjugate addition; it reacted further and furnished the C₁-C₈ fragment of callipeltoside A in 65% overall yield.

Scheme 221. The Synthesis of the Tetrahydropyranyl Ring Systems of Lyngbouilloside (512) and Callipeltoside A (513)

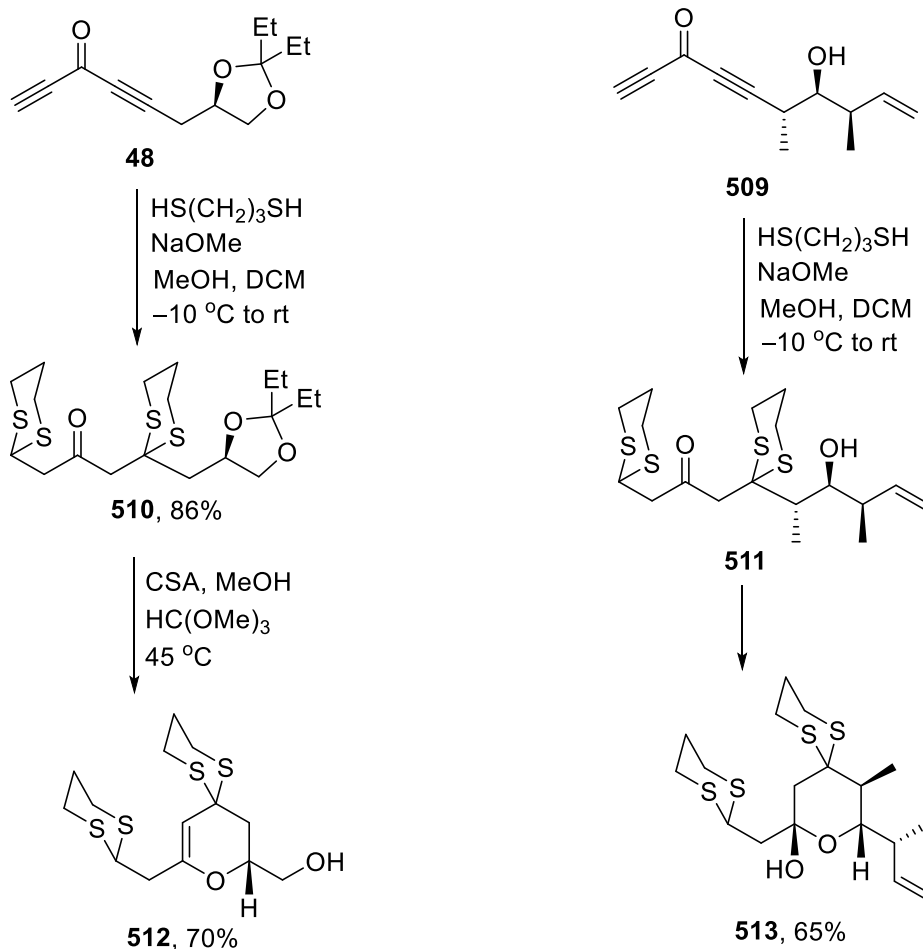

Hemiacetalization similar to that completing the synthesis of tetrahydropyran **513** was also observed by Sydnes and co-workers treating derivatives of 1,1-diethoxy-5-hydroxyalk-3-yn-2-one **375** with propan-1,3-dithiol under standard conditions.⁴¹⁴ The resulting functionalized 2-oxa-6,10-dithiaspiro[4.5]decanes **514** were obtained in excellent yield except when $\text{R} = \text{Ph}$ when it dropped to 44% (Scheme 222). In order to prevent cyclization, the hydroxyl group was benzylated to give compound **515**, and this paved the way for formation of the partly protected diketonaldehyde **516**, which was obtained in excellent yield.

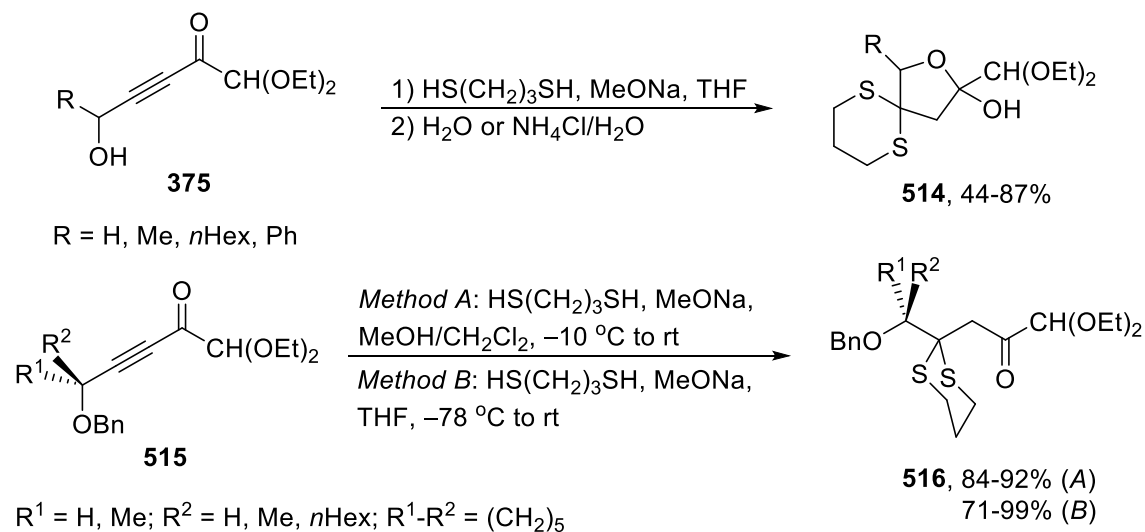
Scheme 222. Reaction of Yrones 375 and 515 with Propane-1,3-dithiol

Marinelli and co-workers reported that when β -(2-aminoaryl)ynones **200** were treated with sodium *p*-toluenesulfinate under slightly acidic conditions the Michael intermediates **I** did not survive and quickly underwent cyclization and formed 4-tosylquinolines **517** in good yields (Scheme 223).³⁰

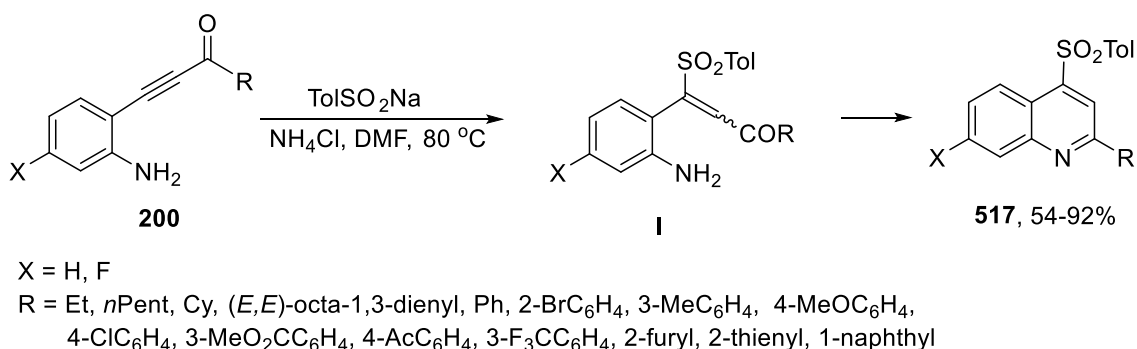
Scheme 223. Conversion of β -(2-Aminoaryl)ynones 200 to 4-Tosylquinolines 517

Intramolecular attack to an ynone by both sulfur and selenium was reported by Kataoka and co-workers who observed a tandem Michael-aldol reaction when 1-(2-methylchalcogenophenyl)prop-2-yn-1-ones (**518**) were treated with BF₃ in the presence of aldehydes and 3-(1-hydroxyalkyl)chalcogenochromen-4-ones **519** were formed in a very slow reaction (Scheme 224).³⁹² For each pair of heterocycles, the selenium compound was isolated in the higher yield. The reaction involves a 6-*endo-dig* cyclization which is made possible by Lewis-acid catalysis. Two mol eq of BF₃ are required, one is consumed in alkoxy-borane formation and the other in trapping released fluoride, giving BF₄⁻ which becomes counter ion to the onium cation generated involving intermediates **I-III**.

Scheme 224. Michael-Aldol Reaction of Ynones 518 with Aldehydes

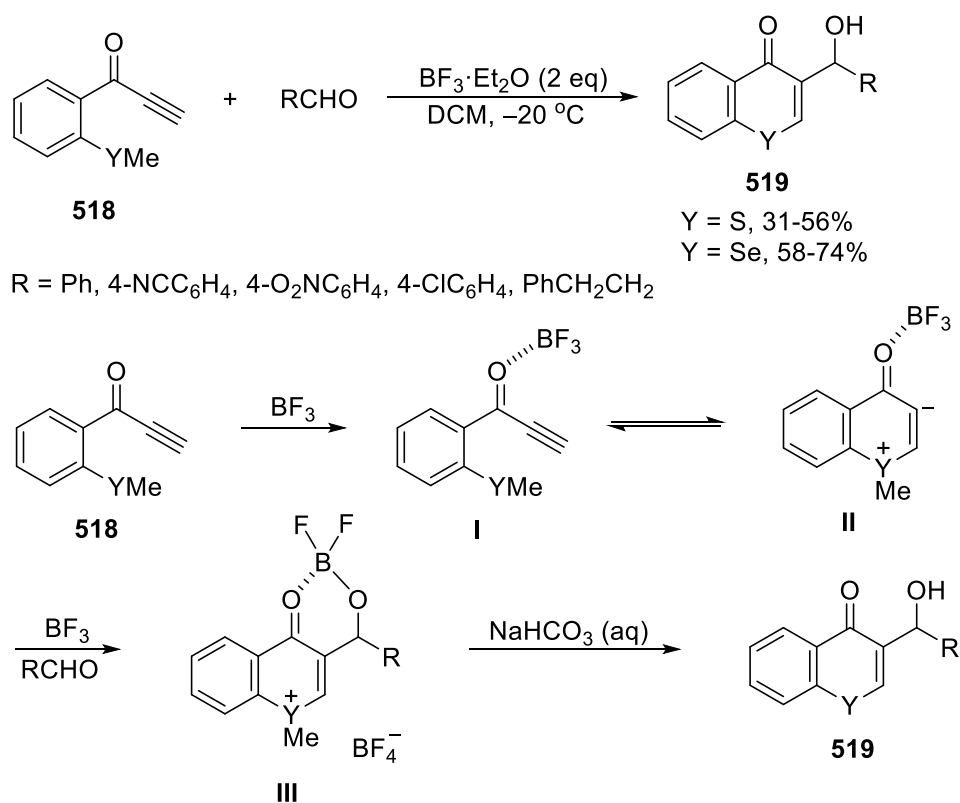

Conjugate addition of thiols and selenols to a range of 1-aryl-3-phenylpropynones **71** has been reported by Zhang and co-workers.⁴¹⁸ The sulfides and selenides, generated from the corresponding disulfides and diselenides by treatment with SmI_2 at elevated temperature, were reacted with ynones and mixtures of ynones and aldehydes at both room temperature and $-28\text{ }^\circ\text{C}$. The former group of reactions gave the corresponding α,β -enones **520** in excellent yields at both temperatures, with a *Z* preference that increased as the temperature was lowered (Scheme 225). When ynone/aldehyde mixtures were applied, however, three-component Michael-aldol tandem reactions occurred instead and afforded the corresponding 3-arylchalcogeno-2-(1-hydroxyalkyl)-prop-2-en-1-ones **521** in excellent yields at both temperatures and a significantly higher *Z* preference at the lower temperature.

Scheme 225. Michael Addition of Diorganyl Diselenides or Disulfides to Ynones **71 Promoted by SmI_2**

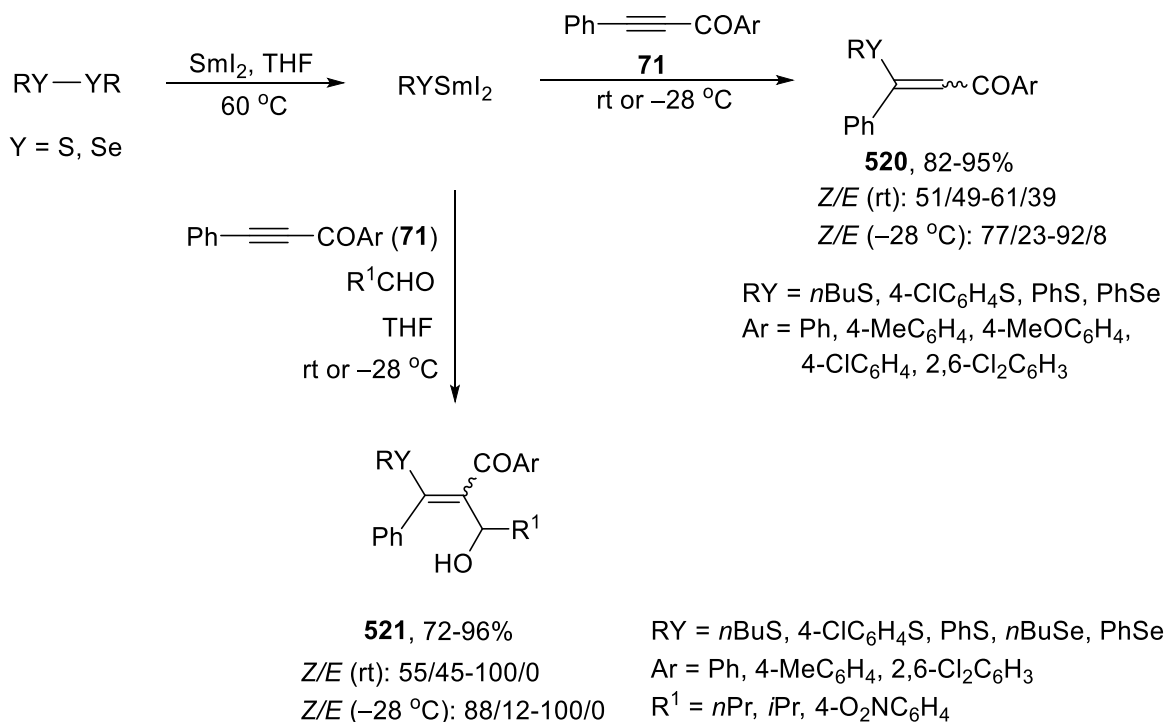

Chalcogenoborates have also been used to perform conjugate addition to ynones **71**, but unlike hydrosilylation using similar reagents,⁴¹³ PhS-Bpin, PhSe-Bpin, and BnS-Bpin react with the ynones in the absence of any transition-metal additives.⁴¹⁹ According to Fernández and co-workers, 16 hours is required to achieve 99% conversion at 50 °C for all reagents and in all cases the reaction is regioselective and affords the corresponding conjugated enones **520** with the chalcogen attached to C-β (Scheme 226). The stereoselectivity with *Z* preference is significantly better when the selenium reagent is used, and this makes it much easier to isolate *Z*-**520** in high yield when Y = Se and S.

Scheme 226. Michael Addition of Chalcogenoborates to Ynones 71

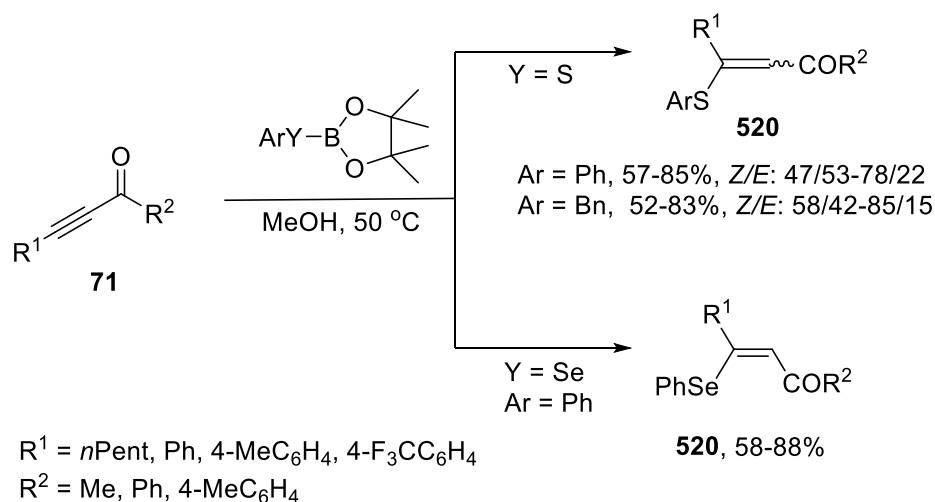

Conjugate addition of a telluride to ynones has been reported by Shimada and co-workers.⁴²⁰ Reduction of bis(*N,N*-dimethylcabamoyl) ditelluride (**522**) followed by addition of ynones **71** resulted in formation of the corresponding monoadduct, *Te*-alkenyl tellurocarbamate **523**, in moderate to excellent yield (Scheme 227). The adducts, formed as a single isomer with *Z* configuration, were crystalline solids, but most of them decomposed when melted. Attempts to make the corresponding selenium compounds from bis(*N,N*-dimethylcabamoyl) diselenide were rather unsuccessful; products were obtained but appeared to be unstable.

Scheme 227. Preparation of *Te*-Alkenyl Tellurocarbamates 523 from Ynones 71

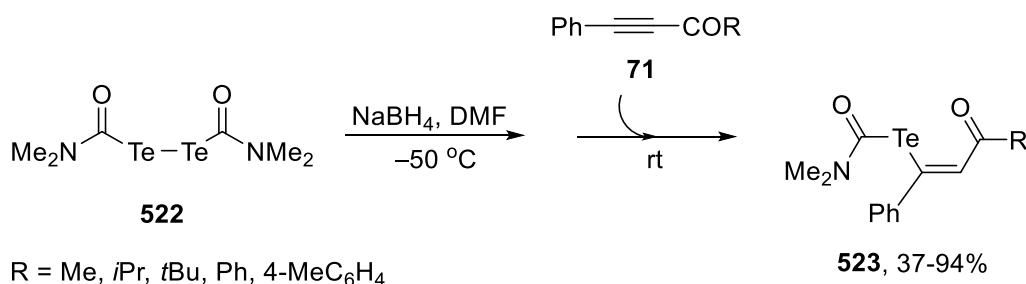

In conclusion, chalcogenides are efficient nucleophiles and react easily by conjugate addition to ynones. Whether mono- or diaddition takes place depends on the nucleophile/triple-bond ratio. By far the most useful reaction is diaddition of propane-1,3-dithiol which gives the corresponding 1,3-dithiane, generally in excellent yield.

3.1.3.3.4. Chloride and Iodide. Conjugate addition of hydrogen halides can be achieved by treating ynones with sodium chloride and iodide in the presence of a weak acid, but if the primary products contain a nucleophilic center properly positioned, secondary reactions occur with the carbonyl group and give final products other than conjugated alkenones. This was observed by Müller and co-workers who treated γ -hydroxylated ynones **524**, obtained from acyl chlorides by Sonogashira coupling (Section

2.2.2.1), with sodium chloride and iodide under acidic conditions (PTSA) and obtained 3-halofurans **525** as the final products, in 29-73% yield (from acyl chloride)^{145,146}. The same strategy and almost identical conditions (*t*-BuOH instead of MeOH) were also applied with *N*-Boc-protected γ -aminoyrones (**526**), obtained from acyl chlorides by Sonogashira coupling (Section 2.2.2.1), and as anticipated the corresponding 2-substituted *N*-Boc-4-iodopyrroles **527** were the final products, which were isolated in 61-75% yield (from acyl chloride) (Scheme 228).¹⁴⁷

Scheme 228. Addition of Chloride and Iodide to γ -Hydroxy Yrones 524

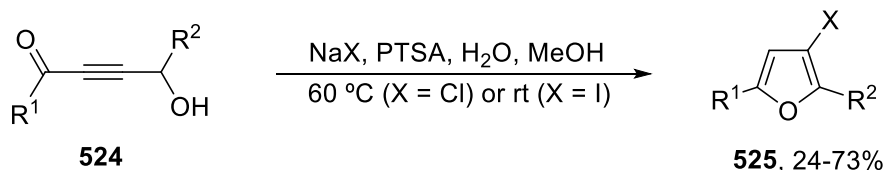

R^1 = *i*Pr, Ph, 4-MeOC₆H₄, 4-O₂NC₆H₄, 2-FC₆H₄, 2-thienyl, PhCH=CH, 1-cyclohexenyl
 R^2 = H, Et, 4-MeOC₆H₄

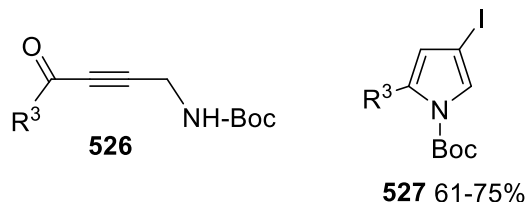

R^3 = Ph, 4-MeC₆H₄, 3-MeC₆H₄, 2-MeC₆H₄, 4-MeOC₆H₄, 4-Cl, 4-FC₆H₄, 2-thienyl,
 PhCH=CH, *c*-C₃H₅, 1-adamantyl

Conjugate addition of hydrogen iodide has also been applied by Marinelli and co-workers to convert a series of ynones (**200**) into the corresponding 4-iodoquinolines (**529**) by cyclization/dehydration (Scheme 229).⁴²¹ The products were not isolated, but used directly in one-pot Pd(0)-coupling reactions with 2-alkynylanilides (**528**) to make a range of 4-(1*H*-indol-3-yl)quinolines **530**, so yields given are for the coupling products from **200**.

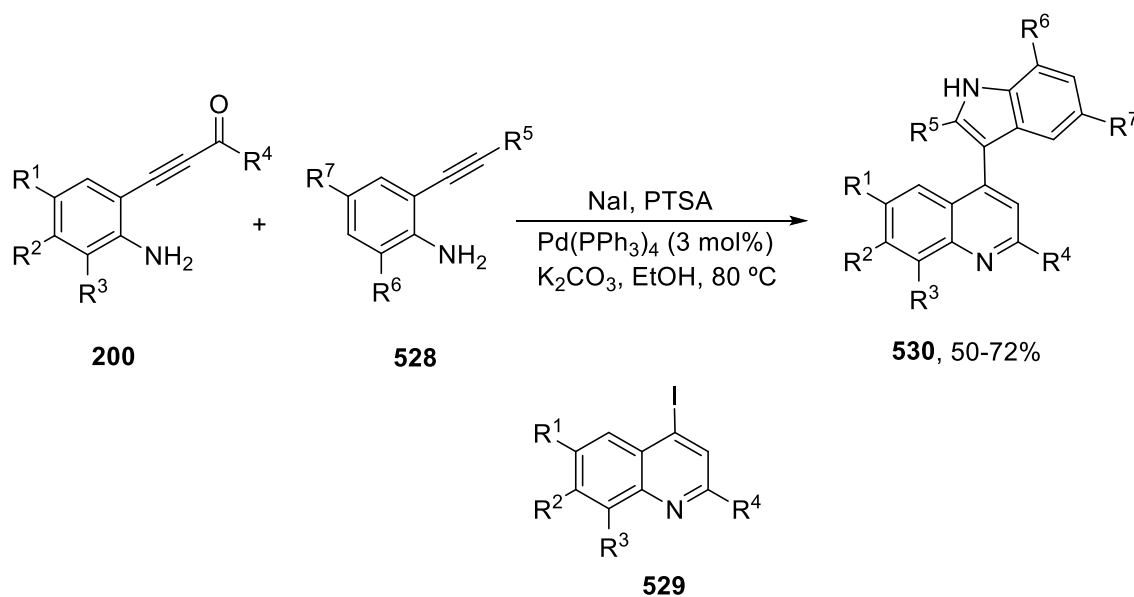
Scheme 229. Conversion of Yrones 200 into 4-Indolylquinolines 530

$R^1 = \text{H, F}; R^2 = \text{H}; R^3 = \text{H, F}$

$R^4 = 4\text{-MeOC}_6\text{H}_4, 3\text{-MeC}_6\text{H}_4, 4\text{-EtO}_2\text{CC}_6\text{H}_4, 4\text{-AcC}_6\text{H}_4, 2\text{-MeOC}_6\text{H}_4, 4\text{-NCC}_6\text{H}_4$

$R^5 = \text{Ph, 2-thienyl, 3-MeO}_2\text{CC}_6\text{H}_4, 4\text{-NCC}_6\text{H}_4, 4\text{-AcOC}_6\text{H}_4, \text{cycloocten-1-yl}$

$R^6 = \text{H, F}; R^7 = \text{H, F}$

Chloride attack to ynones **71** in the presence of aldehydes has been used to prepare β -chloro- α -(1-hydroxyalkyl)- α,β -alkenones (**531**), so-called β -chloro Baylis-Hillman adducts. Li and co-workers performed the synthesis by simply mixing aldehyde, α,β -acetylenic ketone, and TiCl_4 in DCM in a closed vial kept at room temperature.⁴²² As the results in Scheme 230 show, both aliphatic and aromatic aldehydes react and give **531** in good to very good yield. A noteworthy feature is the stereoselectivity; in all cases the *E/Z* ratio is better than 94:6, which conceivably is a consequence of constraints when the intermediate, allenolate **532**, attacks the aldehyde. One reaction was also carried out using TiBr_4 which gave the bromo analogue to **531** in good yield but with lower stereoselectivity (*E/Z* = 8:1). Comparable results were obtained by Watanabe and co-workers when but-3-yn-2-one was reacted at 0 °C in the presence and absence of Me_2S .^{423,424}

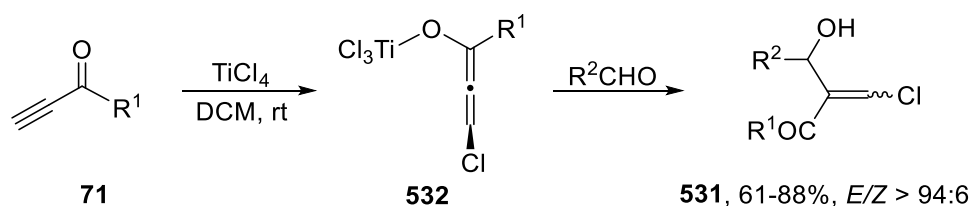
Scheme 230. Conversion of Yrones 71 to β -Chloro- α -(1-hydroxyalkyl)- α,β -alkenones 531

$R^1 = \text{Me, Ph, Cy}$

$R^2 = t\text{Bu, } n\text{Pent, } n\text{Non, Ph, 4-ClC}_6\text{H}_4, 4\text{-BrC}_6\text{H}_4, 4\text{-F}_3\text{CC}_6\text{H}_4, 4\text{-O}_2\text{NC}_6\text{H}_4, \text{CO}_2\text{Et}$

Li and co-workers did not try to control the enantioselectivity of the chiral center in compounds **531**.⁴²² That was, however, attempted by Sugiura, Nakajima and co-workers who performed the chlorinative aldol reaction in the presence of a number of chiral biphosphine-oxides as Lewis base catalysts.⁴²⁵ The chlorinating agent was tetrachlorosilane, which has been applied frequently in asymmetric syntheses with such catalysts, whereas the organic reactants were phenyl ethynyl ketone (**71**) and benzaldehyde. Without catalyst, no reaction occurred, but when 10 mol% of a phosphine-oxide was added 3-chloro-2-(hydroxy)(phenyl)methyl-1-phenylprop-2-en-1-one (**531**) was formed. The best result is shown in Scheme 231 using DMPP-DIOPO as catalyst, the final product being obtained as a ca. 1:1 mixture of *E/Z* diastereomers and with low enantioselectivity.

Scheme 231. Conversion of Ynone 71 into 3-Chloro-2-(hydroxy)(phenyl)-methyl-1-phenylprop-2-en-1-one (531)

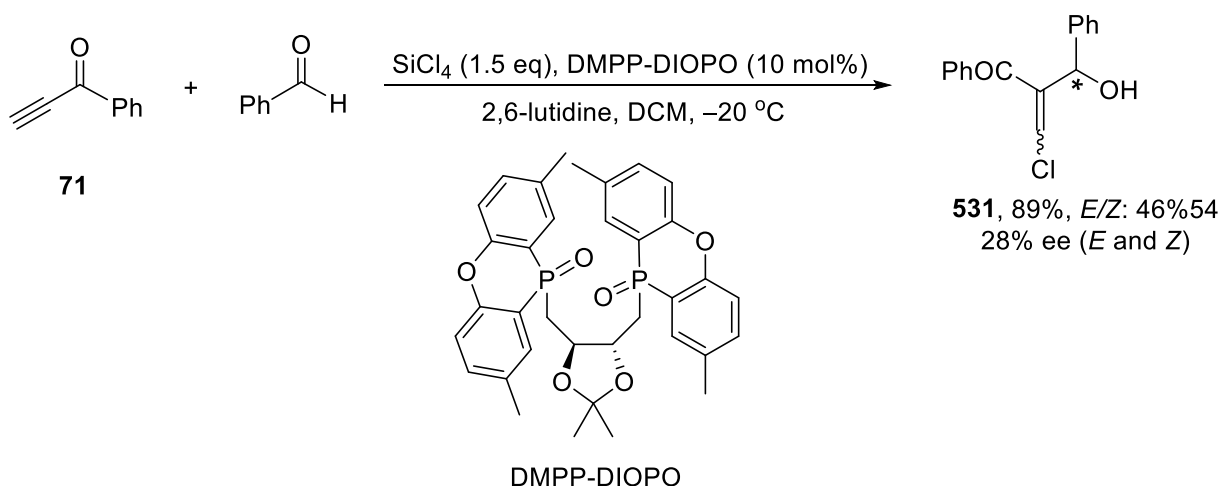

3.1.3.3.5. *Tin*. Podesta and co-workers have reported hydrostannation of ynones (**71**) by $(\text{PPh}_3)_2\text{PdCl}_2$ -catalyzed addition of trineophyltin hydride.⁴²⁶ In all cases the addition products (**533** and **534**) were formed in better than 80% yield (Scheme 232), which is significantly better than when radical hydrostannation was performed (Section 3.1.4.1). It is also noteworthy that the reaction shows regioselectivity for α adducts and stereoselectivity for *E* configuration in seven of the eight cases studied.

Scheme 232. Pd-Catalyzed Trineophyltin Hydride Addition to Ynones 71

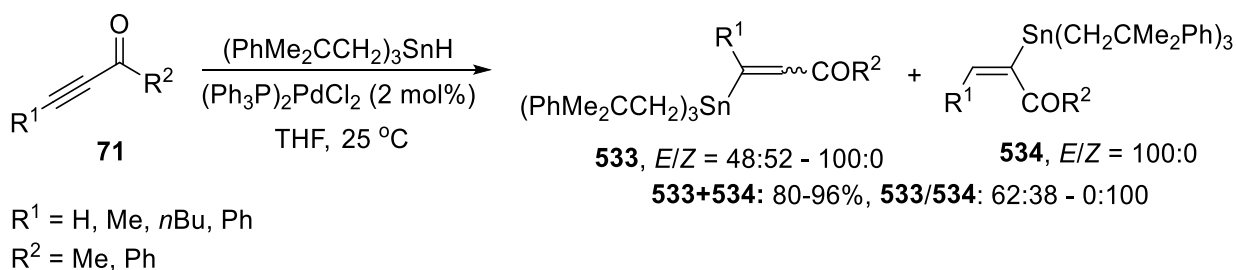

3.1.4. Radical Additions. A few radical reactions have been used to perform addition of certain fragments or compounds to the triple bond in conjugated ynones. The successful reactions can be divided in two groups. In all reactions except one, the radical fragment reacting with the ynone is generated from a reactant and this moiety remains attached to the carbon atom attacked in the first place in the final product. In the deviating reaction, metal-induced electron transfer to the ynone generates a radical anion which subsequently gives the product by a cascade of reactions involving both the added electrophile and the metal.

3.1.4.1. Via Radical-Induced Bond Formation. A classical reaction belonging to this category is hydrostannation, which most frequently has occurred via anions under metal catalysis (Section 3.1.3.3.1), but also can take place via radical intermediates.⁴²³ Two radical transformations have been studied by Podesta and co-workers to achieve addition of trineophyltin hydride to alkynones (**71**) affording stannylenones **533/534**.⁴²⁶ The best results were obtained when the reaction was initiated by AIBN; under these conditions all the ynones reacted, but the yield ranged from 88% to 2.5%, the regioselectivity from complete α attack to complete β attack, and the stereochemistry from only *Z* to only *E* (Scheme 233). Additions under triethylboron initiation show a similar pattern, but the yields are much lower and were acceptable in two cases only. These radical hydrostannations are therefore inferior to the metal-catalyzed analog with regard to both yield and selectivities (Section 3.1.3.3.5).

Scheme 233. Trineophyltin Hydride Radical Addition to Ynones 71

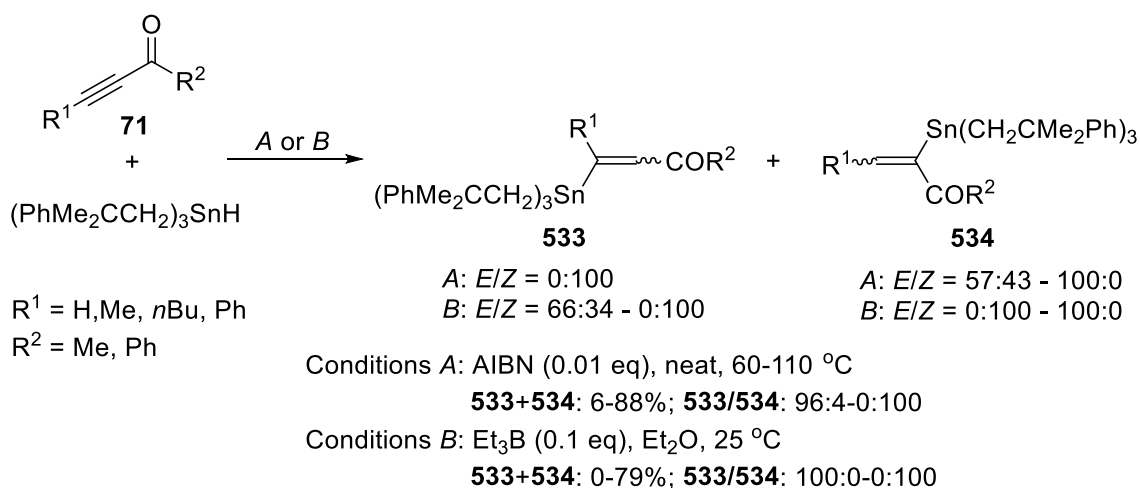

In a pioneering study, Zhang and co-workers reported the conversion of 1,3-diarylpropynones **71** to the corresponding 3-aryl-2-dimethoxyphosphinyl-1-indenones (**535**) by treatment with dimethyl phosphonate in the presence of Mn(OAc)₃.^{427,428} The reaction is triggered by Mn(III) which converts the phosphonate into the dimethylphosphonyl radical, an electrophilic species that is more reactive toward the conjugated ynone than the phenyl ring and attacks the α carbon (Scheme 234). The resulting radical (**I**) then cyclizes by attack of the benzoyl aryl group and form radical **II**,

which is oxidized by Mn(III) and affords cation **III**, precursor of the final product **535**. A large number of alkynones have been reacted under optimized conditions, and as long as both substituents are fairly reactive phenyl groups, the indenones were formed in 64-79% yield. If at least one of the substituents was hydrogen or an alkyl group, complex reaction mixtures were obtained.

Scheme 234. Radical Phosphonation of Ynones **71 to Indanones **535****

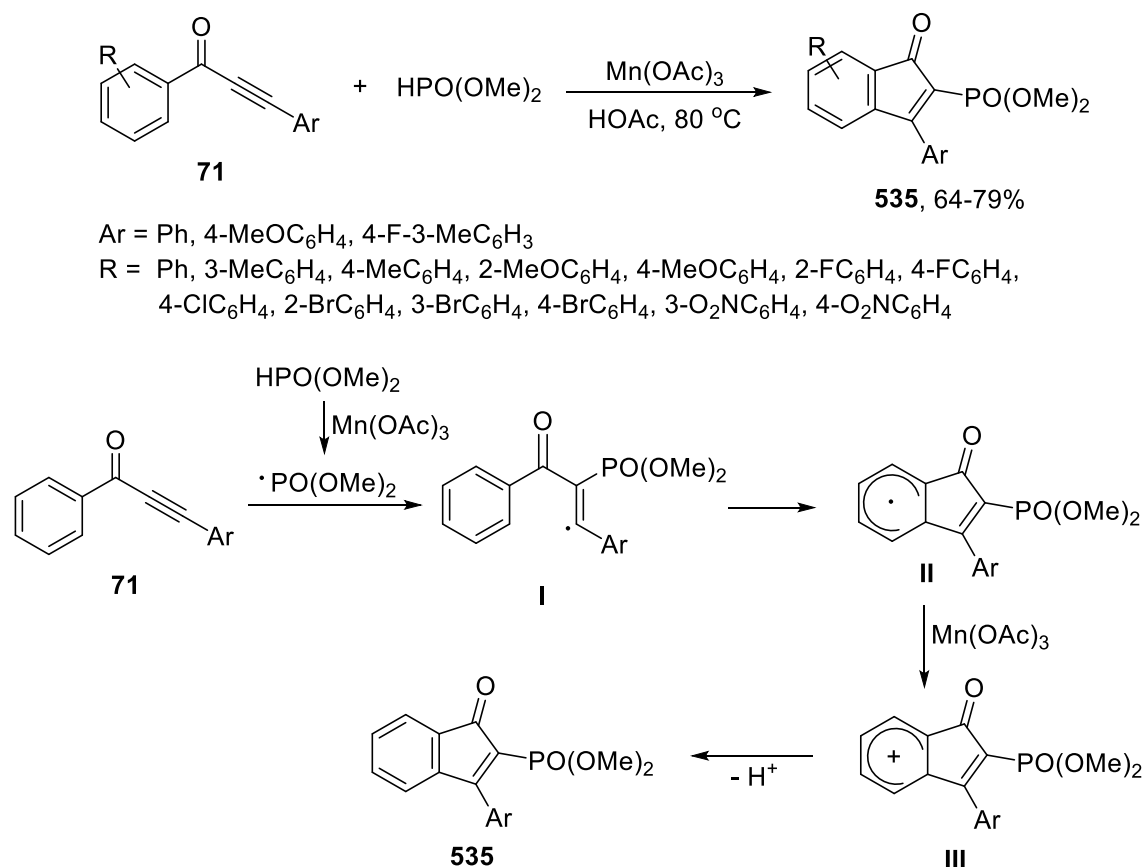

Based on the ability of manganese(III) to convert thiols into sulfur-centered radicals,⁴²⁹ Zhang, Zhou and co-workers explored if indenones could be prepared by treating thiols with Mn(III) in the presence of ynones.⁴²⁸ Screening of aliphatic and aromatic thiols revealed that thiophenols worked quite well under conditions similar to those applied to achieve phosphonation of the 1,3-diarylynones **71** and gave the corresponding 3-aryl-2-thiophenyl-1-indenones **536**, albeit in consistently lower yield than the phosphonyl analogues (Scheme 235). The mechanism is supposed to be essentially identical to that depicted in the Scheme 234.

Scheme 235. Radical Addition of Thiols to Ynones **71**

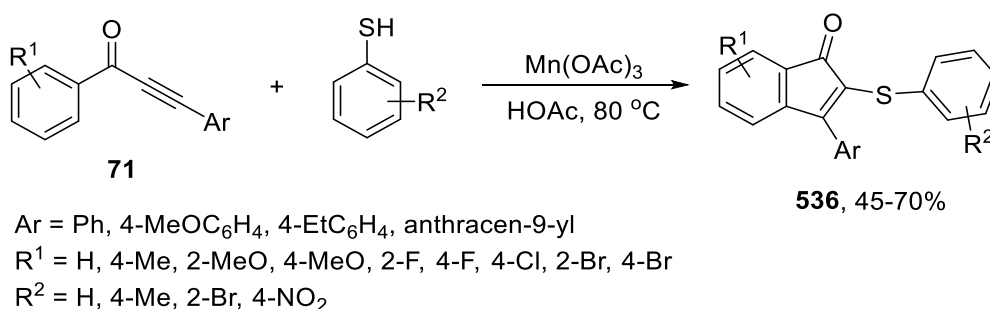

Lei and co-workers have developed an electrochemical method to generate sulfur radicals from sulfinic acids.⁴³⁰ Under oxidative conditions, applying constant current, sulfonyl radicals are formed and react with 1,3-diarylprop-2-yn-1-ones **71** that undergo arylsulfonation in a radical tandem process and afford 2-sulfonated indenones **537**. Optimization experiments were performed with 1,3-diphenylprop-2-yn-1-one and benzenesulfinic acid, and under the best conditions (Pt electrodes, constant 10 mAcm⁻², undivided cell, TBAI as catalyst, LiClO₄ as electrolyte, and MeCN/DCE as solvent) a number of ynones were reacted and gave **537** in up to 90% yield (Scheme 236). The general trend is the same as for similar radical cyclizations: substrates with electron-rich phenyl groups attached to C-1 are the most suitable and give the highest yield, but halide substituents are also well tolerated. Different sulfinic acids also worked well and both electron-rich and electron-poor acids furnished the expected cyclized products in good yields. A number of experiments were performed to shed light on the reaction mechanism, and the results supported the mechanism depicted in Scheme 237 involving radicals **I** and **II**. It should also be noted that Lei succeeded in achieving radical tandem cyclization when benzenesulfinic acid was replaced by benzenesulfonyl hydrazide as the coupling partner, but the yield dropped from 88 to 66%.⁴³⁰

Scheme 236. Radical Addition of Sulfinic Acids to Ynones **71**

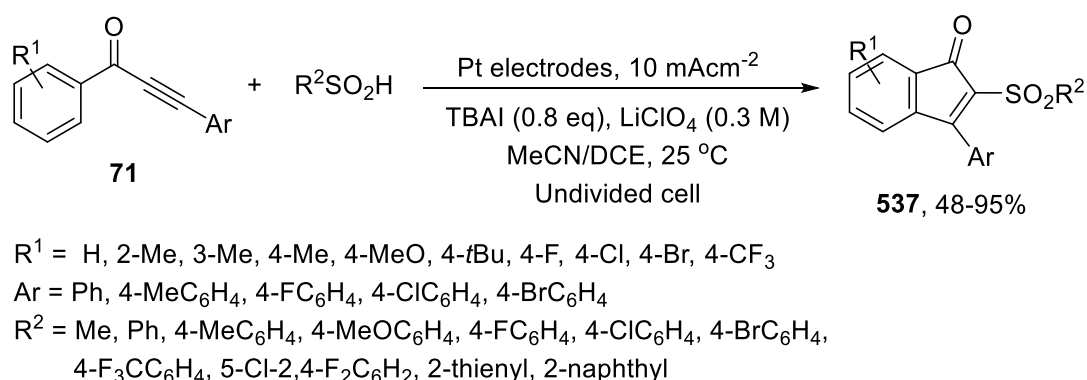

Scheme 237. Proposed Mechanism for the Formation of Sulfonated Indenones **537** from 1,3-Diphenylpropynone **71** by Electrooxidative Tandem Cyclization

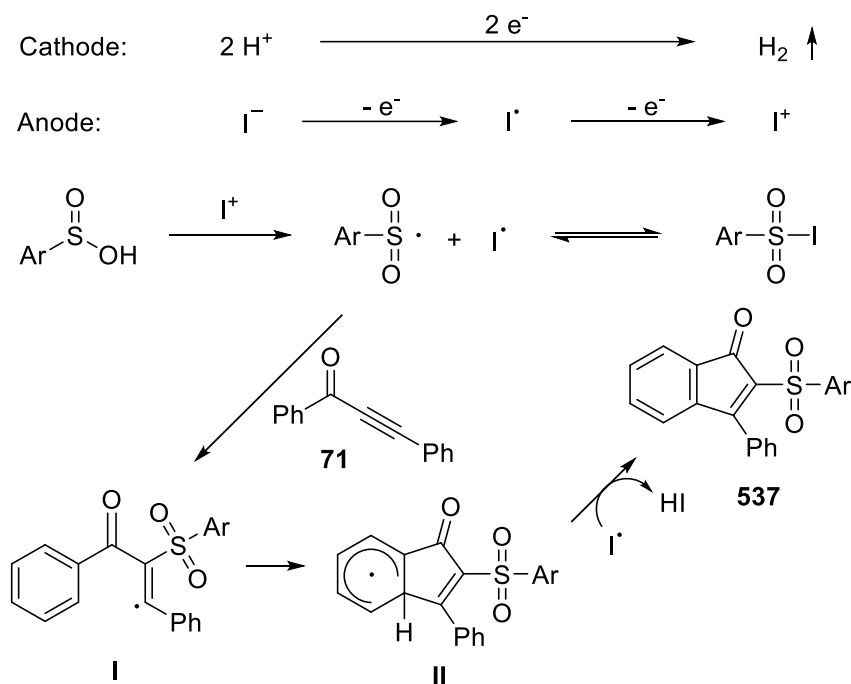

Benzoyl peroxide (BPO) is a common initiator of radical reactions, and Pan and Yu and co-workers describe application of BPO to induce radical annulation of conjugated 1,3-diarylpropynones with alkanes to afford 2,3-disubstituted indenone derivatives under mild, metal-free conditions.⁴³¹ The optimum conditions for the transformation were worked out by using 1,3-diphenylprop-2-yn-1-one (**71**) and cyclohexane along with BPO as reactants, and under these conditions a large number of ynones were reacted with cycloalkanes $(\text{CH}_2)_n$, $n = 5-8$, and gave consistently the corresponding 2-cycloalkylindenones **538** in moderate to good yields (Scheme 238). Two reactions were also carried out with acyclic alkanes, such as pentane and 2-methylbutane, and isomeric mixtures were formed in moderate yields, 64% and 58%, respectively, with isomeric compositions in accordance with a hydrogen-abstraction preference of $3^\circ > 2^\circ \gg 1^\circ$ carbons. The mechanism presented in Scheme 238 has been proposed for the reaction involving radicals **I** and **II**.

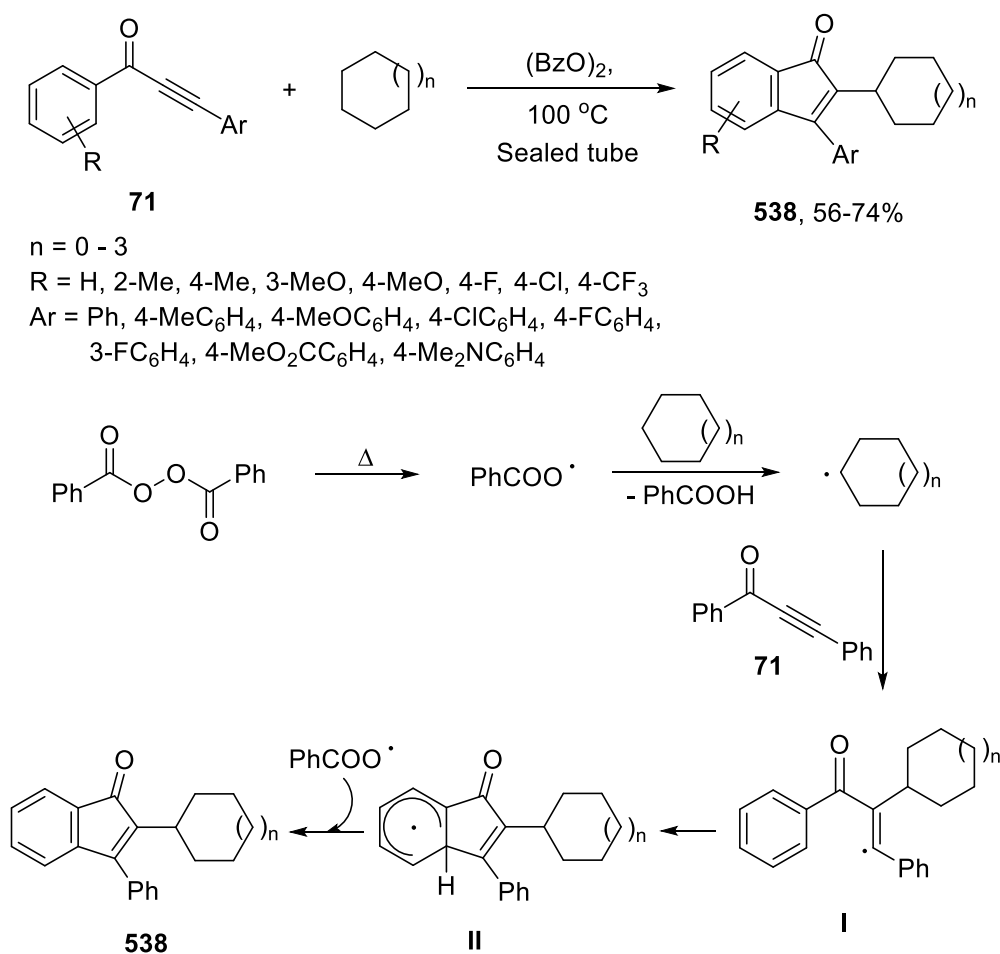
Scheme 238. Radical Cyclization of Yrones **71 with Cycloalkanes**

The ability of ynones to function as radical acceptors has also been utilized by Pattenden and co-workers to carry out intramolecular radical-mediated Diels-Alder reactions to obtain a variety of polycyclic molecules. These reactions are discussed in Section 3.2.4.

In conclusion, the most successful radical-induced reactions have been performed between C, P and S radicals and 1,3-diarylprop-2-yn-1-ones, which give 2-substituted inden-1-ones in moderate to good yields. The reaction is initiated by radical attack at α -C.

3.1.4.2. Via Ynone Radical Anions. In a study by Watanabe and co-workers,⁴³² Mg was used as reducing agent to promote reductive silylation of a number of conjugated ynones (**71**) in the presence of various silanes. The final product depended on how the reaction mixture was worked up. When 4-phenylbut-3-yn-2-one was reacted and the reaction mixture was worked up without hydrolysis, multifunctionalized allenes (**539**) were obtained due to silylation of both the β carbon and the oxygen atom of the carbonyl group. As long as trialkylsilyl chlorides were used as electrophiles, one product was obtained (Scheme 239), but silanes containing two chlorine atoms furnished complex reaction mixtures. And when the structure of the ynone was varied and

chlorotrimethylsilane was used as trapping agent, **539** was obtained in good yields if an aryl group was attached to the β carbon. However, if the reaction mixture was hydrolyzed before work-up, the vinyl-ether moiety of the allene **539** suffered hydrolysis and the final product became the enone **496** (which formally can be regarded as the product from hydrosilylation of the ynone triple bond). The same group also performed mechanistic studies, and on the basis of the formation of certain by-products and cyclic-voltammetry studies, a reaction mechanism involving single-electron transfers and radical-anion formation has been proposed.

Scheme 239. Mg-Promoted Radical Silylation of Yrones **71**

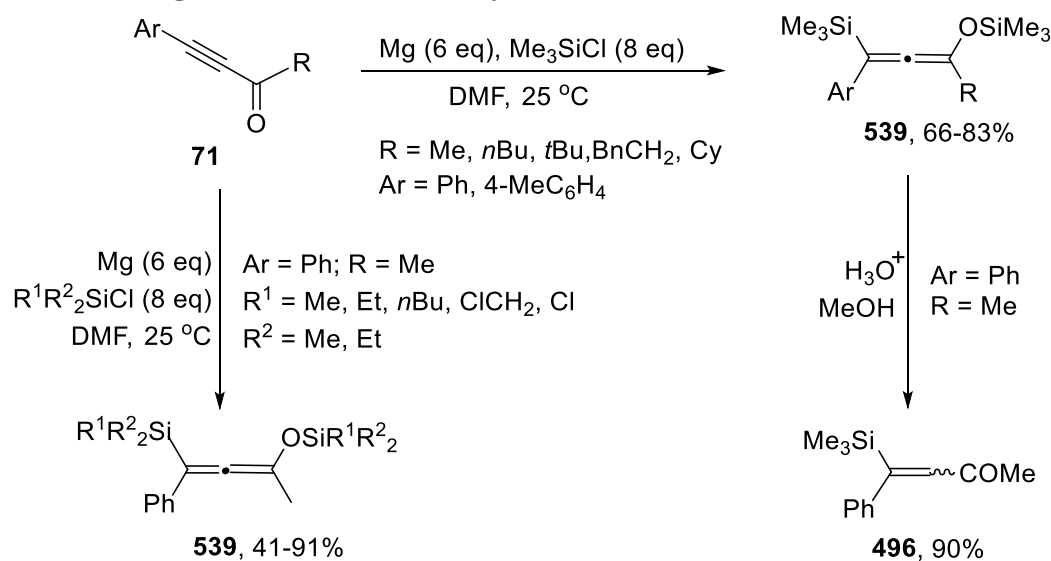

3.2. Cycloaddition Reactions

Yrones have been used as substrates in a range of cycloaddition reactions. Most of the applications are in 1,3-dipolar cycloadditions (Huisgen reaction), but some Diels-Alder reactions have also been reported. In addition, the number of [2+2] cycloadditions is low.

3.2.1. [2+2] Cycloadditions. An example worthwhile noticing was published by Liou and Cheng in 1995 and reports a [2+2] cycloaddition of hex-3-yn-2-one (**71**) to [60]fullerene mediated by tricyclohexylphosphine (PCy₃).⁴³³ The resulting adduct (**540**) was obtained in 17% yield, but surprisingly the adduct formation had occurred across the β,γ carbon atoms instead of the expected α,β alternative location (Scheme 240). No reaction was observed in the absence of phosphine which indicates that the reaction is initiated by a β attack of **71** and formation of the dipolar intermediate **I** (Scheme 240). A subsequent 1,3-proton shift from the γ to the α carbon gives zwitterion **II** which attacks fullerene, affording **III** that suffers back attack at the ynone β position and finally expulsion of PCy₃ and formation of **540**.

Scheme 240. [2+2] Cycloaddition of Hex-3-yn-2-one (**71**) to [60]Fullerene

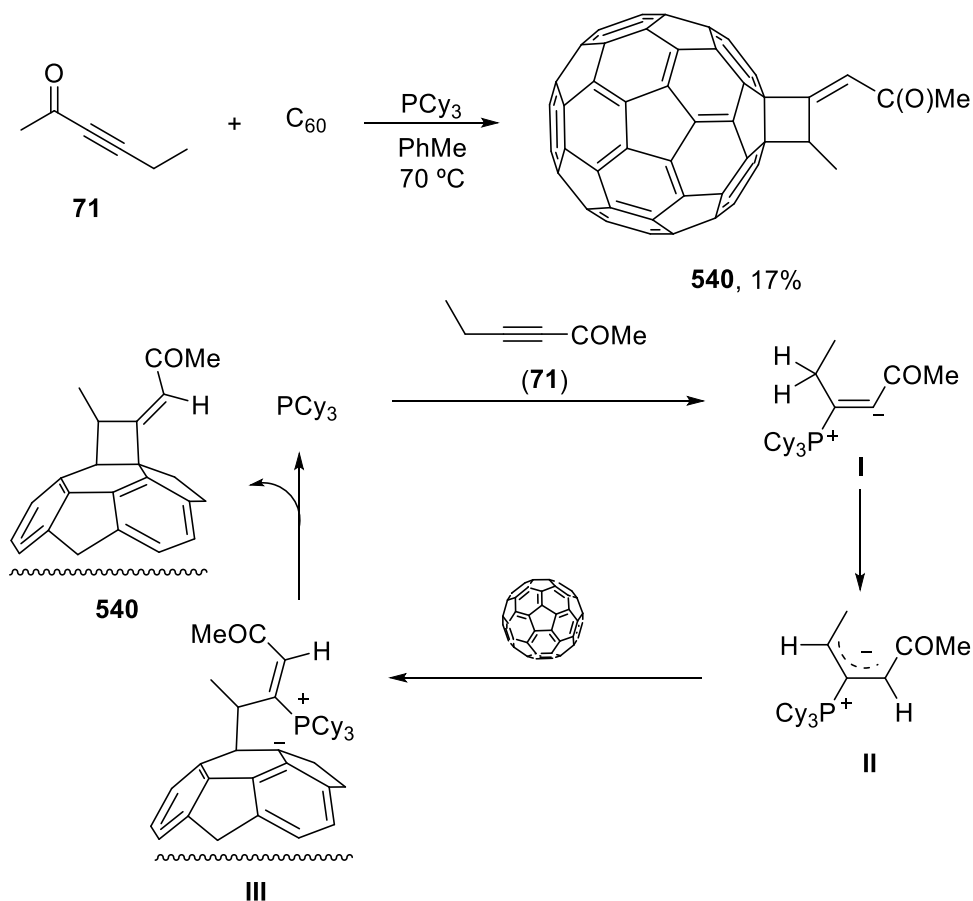

Enamines are known to undergo [2+2] cycloadditions with electrophilic acetylenes under apolar conditions, and in accordance with this, Rossi and coworkers observed cyclobutene formation when 3-(2-aminophenyl)-1-arylprop-2-yn-1-ones (**200**) were reacted with a range of enamines of cyclic ketones. However, the primary products, bicyclo[4.2.0]oct-7-enes (**542**), were not isolated because they suffered an annulation reaction and gave *c*-fused quinolines, in all cases in moderate yield.⁴³⁴ The final product appeared to depend on the structure of the enamine. When 1-(cyclohexen-1-yl)pyrrolidine (**541**) was applied, the bicyclic structure survived and quinolines **543** were the products (Scheme 241), but at temperatures somewhat above 135 °C, **543** appeared to be unstable and was quantitatively converted into the more stable tricyclic quinoline **544**. Furthermore, Rossi discovered that analogues to **544** were the only products isolated when enamines of cyclopentanone and cycloheptanone were reacted with **200** in refluxing toluene; again, the yields were moderate (45-58%). And finally, when enamines derived from aldehydes were applied, enamine decomposition predominated and gave amines which reacted as expected by domino Michael addition/annulation reaction.

Scheme 241. Cycloaddition of Enamine 541 to Ynones 200

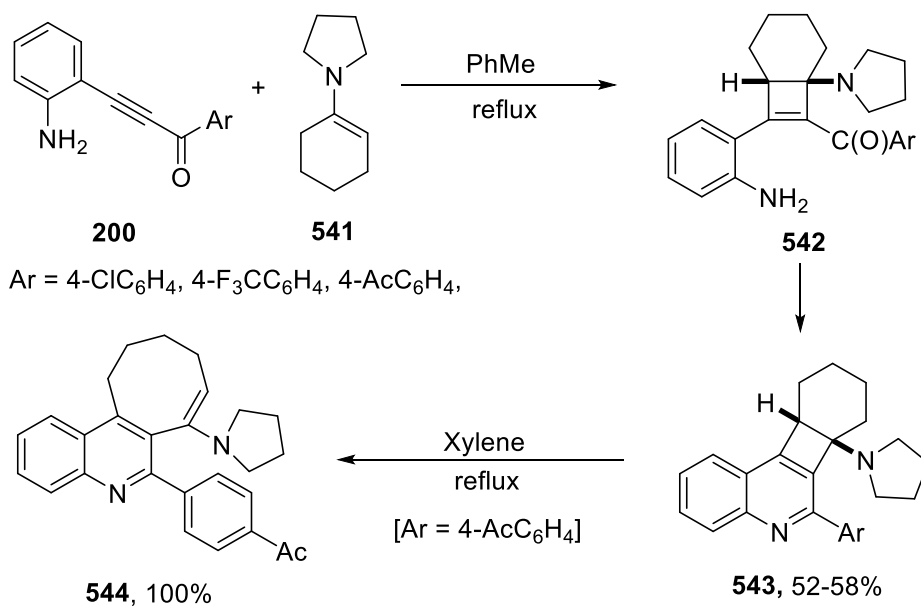

Suzuki has studied the [2+2] cycloaddition of (trialkoxy)siloxyethene (**545**) to ynones **71** with the purpose of making functionalized cyclobutenediones.⁴³⁵ The siloxy group appeared to direct the attack of the triple bond persistently and gave the corresponding cycloadduct with the acyl and siloxy groups in a 1,2 relationship (**546**) (Scheme 242). The yield was above 90% in most cases under the optimum reaction conditions, but at higher temperature thermal ring opening followed by silyl migration and formation of a 1,3-diene occurs.⁴³⁵ A virtue is the regioselectivity: when there is a choice between a conjugated double and triple bond, the latter is exclusively attacked and a terminal triple bond reacts before an internal analogue.

Scheme 242. Cycloaddition of Trimethoxysiloxyethene (**545**) to Ynones **71**

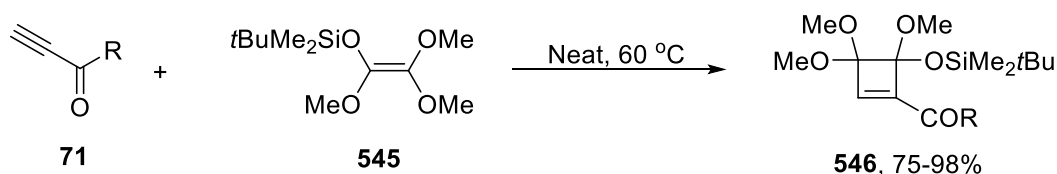

R = Me, Ph, (*E*)-PhCH=CH, PhC≡C, cyclohex-1-enyl

Zhang has studied the reaction between 1-(4-methoxyphenyl)-3-phenylprop-2-yn-1-one (**71**) and rutheniumcarbonyl cluster Ru₃(CO)₁₂ systematically.⁴³⁶ The alkyne turned out to be a robust ligand that induced stepwise transformations at 90 °C and gave complex product mixtures, the composition of which was mainly determined by the molar ratio between the two reactants. When heated in toluene (90 °C) in a 1:1 ratio, metal clusters **547** and **548** were obtained in fair yields (Scheme 243). Both clusters contained a metalcyclobutene motif, formed by [2+2] cycloaddition of the cluster to the ynone triple bond, where the C-C double bond is engaged in a bond to a ruthenium atom. When **547** was treated with 1 eq of ynone **71**, a 60% yield of **548** was obtained. However, the compound is not stable; it decomposes and three metalacyclopentadiene derivatives, termed ruthgenoles, were formed.⁴³⁶

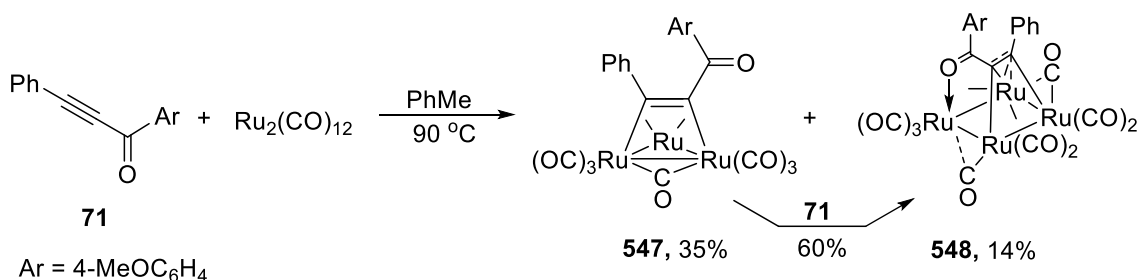
Scheme 243. Cycloaddition of Ru₂(CO)₁₂ to Ynone 71

In conclusion, few [2+2] cycloaddition reactions with ynones have been reported. The primary products are cyclobutenes, which in general are unstable and undergo isomerization or electrocyclic ring-opening reactions.

3.2.2. [3+2] 1,3-Dipolar Cycloadditions. Ynones are powerful dipolarophiles and have been used in Huisgen 1,3-dipolar cycloadditions with different dipoles, such as azides, nitrones, azomethine imines and ylides, nitrile oxides and diazo compounds, to provide five-membered heterocycles.^{437,438}

3.2.2.1. Azides. The copper(I)-catalyzed azide-alkyne cycloaddition (CuAAC) was described by Sharpless⁴³⁹ and Meldal.⁴⁴⁰ In the case of ynones, the corresponding 4-acyl-1*H*-1,2,3-triazoles (**549**) are obtained. Friscourt and Boons⁴⁴¹ reported a microwave-assisted one-pot synthesis of these triazoles by *in-situ* preparation of silylated ynones by reaction of benzoyl chlorides with silylacetylenes under Pd/Cu-catalyzed conditions (Section 2.2.2.1) followed by *in-situ* desilylation and subsequent CuAAC at 120 °C, giving triazoles **549** in moderate to good yields (Scheme 244).

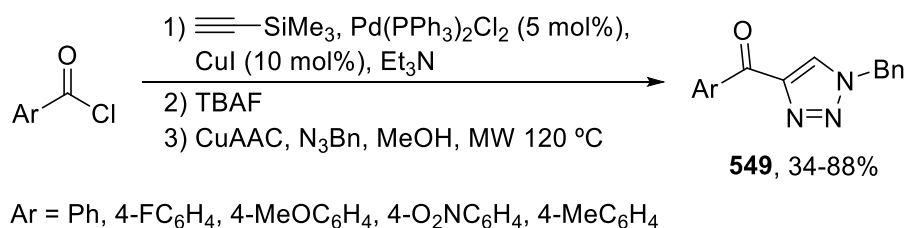
Scheme 244. One-Pot Three-Step Synthesis of 4-Acyltriazoles 549 by CuAAC of Azides with *in-situ* Generated Ynones

Chen and co-workers⁴⁴² have synthesized 4,5-disubstituted 1,2,3-(NH)-triazoles (**550**) in a one-pot synthesis. Carbonylative Sonogashira coupling reaction (Section 2.3) of aryl iodides with terminal alkynes **127** under a CO atmosphere at room temperature, giving ynones **71**, was first performed and then treatment with NaN₃ in DMSO at 45 °C was carried out. The corresponding triazoles were obtained in good yields in the absence of CuI (Scheme 245).

Scheme 245. Carbonylative Sonogashira Coupling of Aryl Iodides with Terminal Alkynes **127 Followed by a AAC with NaN₃**

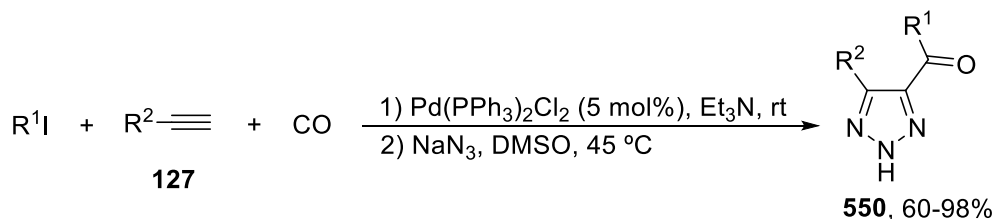

R¹ = Ph, 2-MeOC₆H₄, 4-MeOC₆H₄, 4-EtOC₆H₄, 4-MeC₆H₄, 3,4-Me₂C₆H₃, 1-naphthyl

R² = *t*Bu, *n*C₈H₁₇, Ph, 4-FC₆H₄, 4-*n*C₅H₁₁OC₆H₄, 3-thienyl

The one-pot, two-step synthesis of 4-acyl-1,2,3-triazoles **549** via TIPS-protected ynones has been also reported by Kim and co-workers.⁴⁴³ For the first step benzoyl chlorides were alkylated with TIPS-acetylene under Pd/Cu catalysis at room temperature. Then, 0.5 eq of CuI, 1.5 eq of AgF and different azides were added at room temperature to provide triazoles **549** in 68-84% yields (Scheme 246). Alternatively, the second step can be performed using 10 mol% of CuI, 1.5 eq of AgF and 2 mol% of 1,10-phenanthroline also at room temperature with similar yields (65-85%). The yields are higher than those of Boon's⁴⁴¹ one-pot, three-step process (Scheme 244).

Scheme 246. One-Pot Two-Step Synthesis of 4-Acyltriazoles **549 by a CuAAC of Azides with *in situ* Generated β -Silylated Ynones**

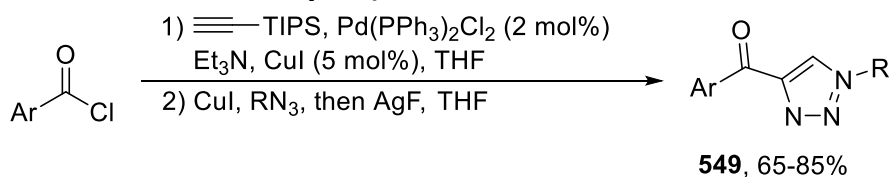

Ar = Ph, 4-FC₆H₄, 4-MeOC₆H₄, 4-O₂NC₆H₄, 2-furyl

R = Bn, 4-MeOBn, 4-O₂NBn, *n*C₈H₁₇, Ph, 4-MeOC₆H₄, 2-thienylCH₂, 2,6-Et₂C₆H₃

Copper-catalyzed 1,3-dipolar cycloaddition of benzyl azide with 1,1-diethoxy-but-3-yn-2-one (**350**) gave regioisomeric triazoles depending on the copper salt.⁴⁴⁴ In the case of CuSO₄ (4 mol%)/sodium ascorbate (11 mol%) triazole **551** was obtained in up to 70% yield at room temperature in aqueous dichloromethane (Scheme 247). However, when CuI, DIPEA and *N*-chlorosuccinimide (NCS) were used at room temperature in aqueous DMF, a mixture of **551** and regioisomer **552** was obtained.

Scheme 247. CuAAC of Benzyl Azide with Ynone **350**

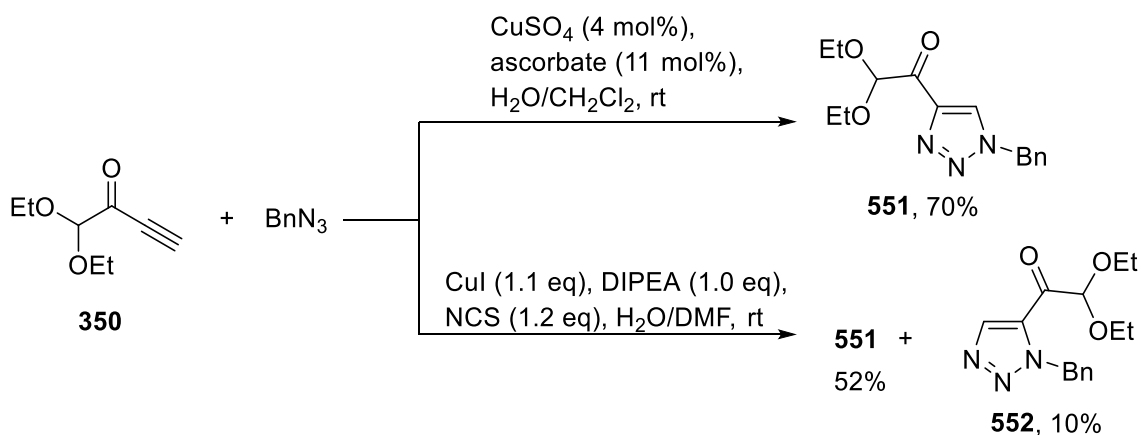

In conclusion, copper-catalyzed 1,3-dipolar cycloaddition of isolable ynones or ynones generated *in situ* took place under mild reaction conditions either with sodium azide or azide compounds.

3.2.2.2. Nitrones. Organocatalytic enantioselective 1,3-dipolar cycloadditions of nitrones have only been described with alkynals affording chiral 4-isoxazolines. Sun and co-workers⁴⁴⁵ employed 20 mol% of α,α -diarylprolinol (**553**) as organocatalyst in the three-component reaction between alkynals **69**, aldehydes and *N*-alkylhydroxylamines in chloroform at room temperature in the presence of 20 mol% of 3,5-dinitrobenzoic acid leading to the formation of 4-isoxazolines **554** in excellent yields and with excellent enantioselectivities (Scheme 248). The proposed catalytic cycle involves formation of an iminium intermediate (**I**) by reaction of **69** with prolinol **553**, which undergoes the stereoselective addition to the *Re*-face of the nitron (**555**), generated *in situ* by condensation of the other aldehyde with the *N*-alkylhydroxylamine through transition state **II**.

Scheme 248. Three-Component Asymmetric Organocatalyzed 1,3-Dipolar Cycloaddition of Alkynals **69 with Aldehydes and Hydroxylamines**

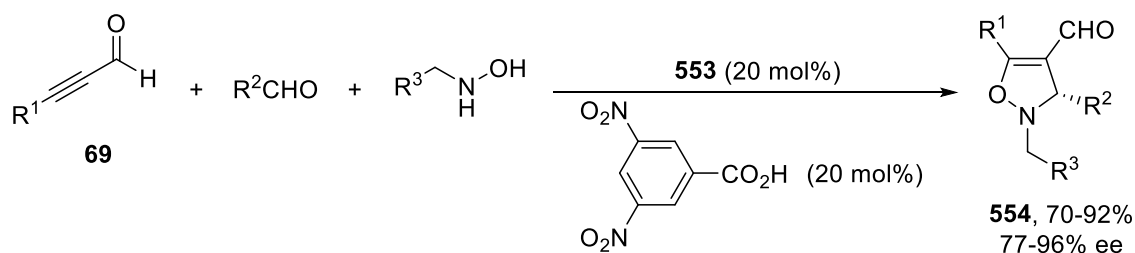

$\text{R}^1 = \text{Ph, 4-MeC}_6\text{H}_4, \text{4-MeOC}_6\text{H}_4, \text{4-F}_3\text{CC}_6\text{H}_4, n\text{C}_4\text{H}_9$

$\text{R}^2 = \text{Ph, 4-MeC}_6\text{H}_4, \text{3-MeC}_6\text{H}_4, \text{4-MeOC}_6\text{H}_4, \text{3-MeOC}_6\text{H}_4, \text{3-ClC}_6\text{H}_4, \text{4-F}_3\text{CC}_6\text{H}_4, \text{2-naphthyl, 2-furyl, 1-propenyl}$

$\text{R}^3 = \text{Ph, 4-MeC}_6\text{H}_4, \text{4-MeOC}_6\text{H}_4, \text{4-FC}_6\text{H}_4, \text{4-F}_3\text{CC}_6\text{H}_4, n\text{C}_4\text{H}_9$

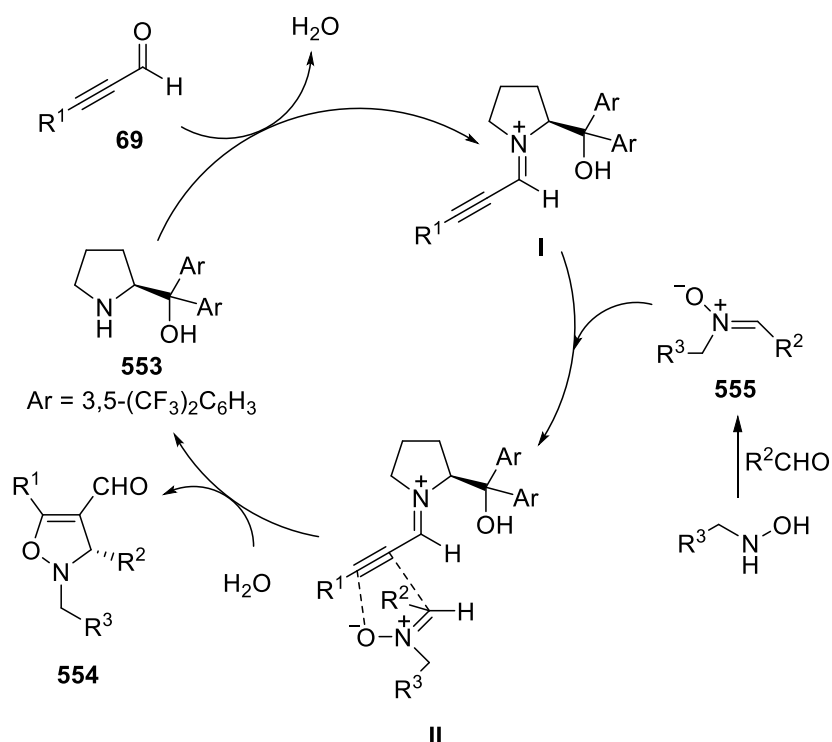

The same 1,3-dipolar cycloaddition has been carried out between nitrones **555** and alkynals **69** using chiral organocatalyst **556**.⁴⁴⁶ The corresponding chiral 4-isoxazolines were obtained in good to excellent yields with good enantioselectivities using toluene as solvent at $-10\text{ }^\circ\text{C}$ (Scheme 249). The absolute configuration of **554** was the same as that exhibited by the 4-isoxazolines shown in Scheme 248.

Scheme 249. Asymmetric Organocatalyzed 1,3-Dipolar Cycloaddition of Nitrones **555** with Alkynals **69**

reacted with ynones **71** giving the corresponding [3+2] cycloadducts (**561**) in good to excellent yields (Scheme 251). The reaction was performed in dichloromethane at room temperature with different ynones **71**.

Scheme 251. Cu(0)-Catalyzed [3+2] Cycloaddition of 2-Benzylidene-3,3-dimethyl-5-oxopyrazolidin-2-ium-1-ide (560**) with Ynones **71****

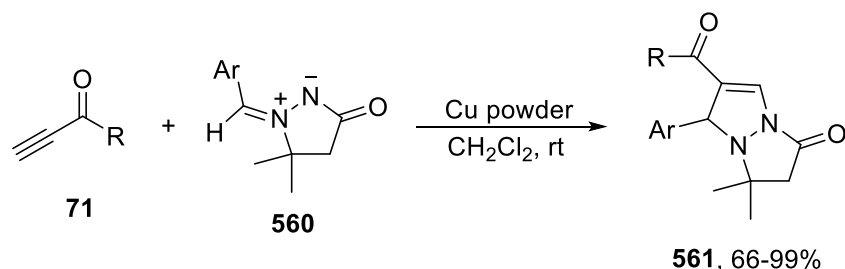

Ar = Ph, 4-ClC₆H₄, 4-O₂NC₆H₄, 3,4,5-(MeO)₃C₆H₂
R = Me, Ph, BocNHCH₂

Further studies from Svete's group using ynones **71** (R = Me) and 4-substituted azomethine imines (**562**) revealed that electron-donating substituents in the Ar moiety increase the reactivity of these dipoles, a trend which is in accordance with how the dipole_{HOMO}-dipolarophile_{LUMO} interaction controls such cycloadditions.⁴⁵⁰ The corresponding cycloadducts **563** were obtained in 70-100% yield (Scheme 252). In order to compare the efficiency of the Cu(0) and Cu(I)/DIPEA catalysts, parallel reactions were performed and adducts **563** were consistently obtained in lower yields with the latter (35-98%).

Scheme 252. Cu-Catalyzed [3+2] Cycloaddition of Azomethine Imines **562 with Ynones **71****

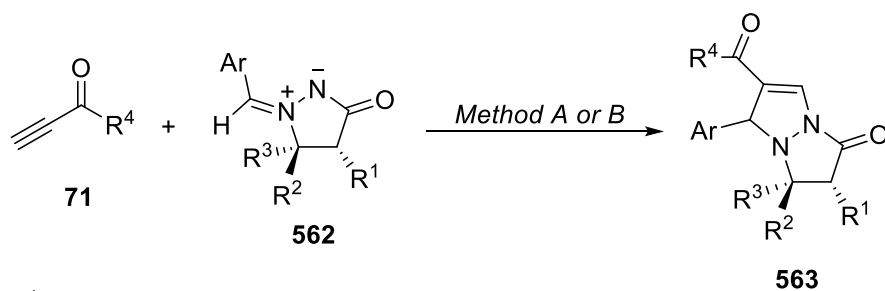

R¹ = BzNH, CbzNH

R² = Me, *i*Pr, Ph

R³ = H, Me

R⁴ = Me, Ph

Ar = Ph, 4-MeC₆H₄, 4-O₂NC₆H₄, 3,4,5-(MeO)₃C₆H₂, 3,4,6-(MeO)₃C₆H₂

Method A: Cu(0) (60 mol%), CH₂Cl₂, rt (70-100%)

Method B: CuI (20 mol%), DIPEA (30 mol%), MeCN, rt (35-98%)

Azomethine imines can be used in [3+3] cycloadditions with ynones under phosphine-catalyzed reactions giving hydroxypyridazine derivatives. Liang and Huang⁴⁵¹ have

described this domino cycloaddition with *N,N'*-cyclic azomethine imines **564** with ynones **71** using 30 mol% of PPh₃ in a 1:1 mixture of *n*BuOH and CHCl₃ at 30 °C affording products **565** in moderate to good yields (Scheme 253). The proposed catalytic cycle starts with conjugate addition of PPh₃ to the ynone to give enolates **I** and **II**. The latter adds to **564** and affords intermediate **III**, which undergoes intramolecular cyclization and generates intermediate **IV**. Product formation is then accomplished by proton transfer to **V** followed by β -elimination of PPh₃.

Scheme 253. PPh₃-Catalyzed [3+3] Cycloaddition of Azomethine Imines 564 with Ynones 71

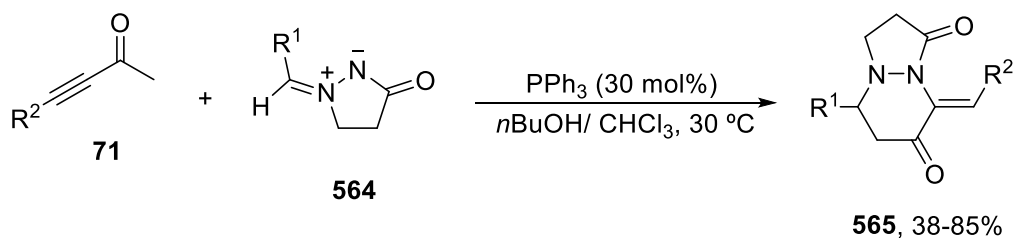

$\text{R}^1 = \text{Ph, 4-BrC}_6\text{H}_4, 4\text{-ClC}_6\text{H}_4, 3\text{-ClC}_6\text{H}_4, 2\text{-ClC}_6\text{H}_4, 4\text{-FC}_6\text{H}_4, 4\text{-MeC}_6\text{H}_4,$
 $4\text{-MeOC}_6\text{H}_4, 4\text{-O}_2\text{NC}_6\text{H}_4, 4\text{-NCC}_6\text{H}_4, 4\text{-F}_3\text{CC}_6\text{H}_4, 2,4\text{-Cl}_2\text{C}_6\text{H}_3,$
 $2\text{-naphthyl, 2-furyl, 3-thienyl}$
 $\text{R}^2 = \text{Ph, 4-MeC}_6\text{H}_4, 4\text{-FC}_6\text{H}_4$

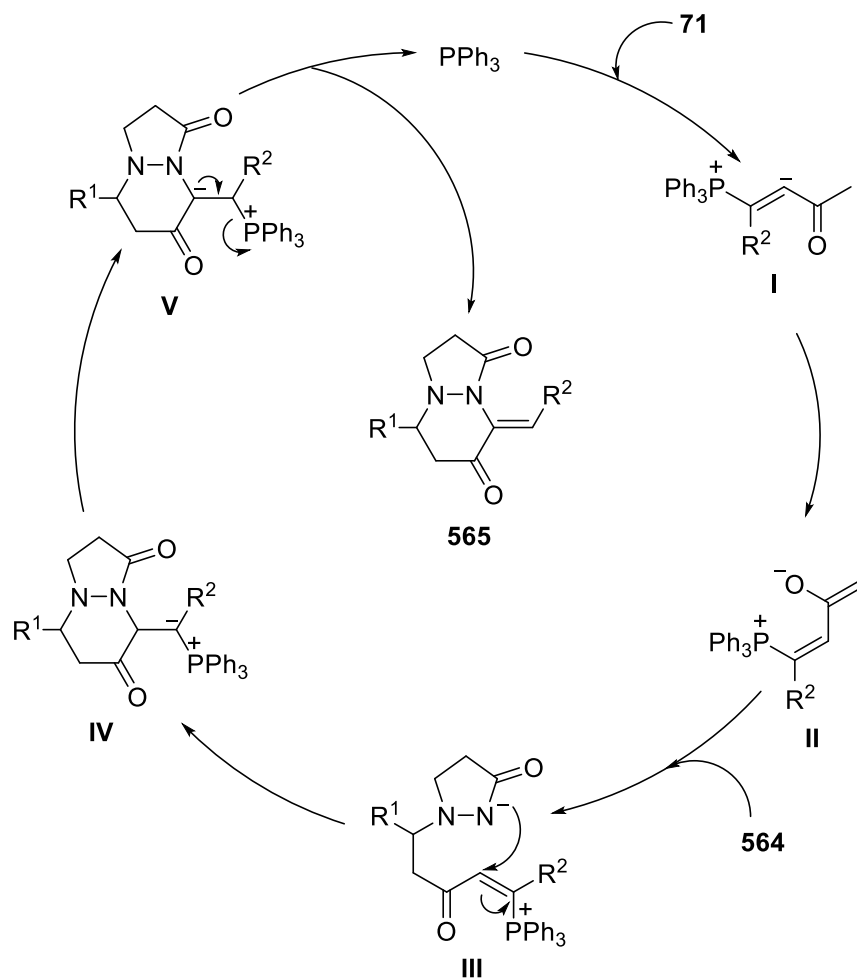

In conclusion, only copper-catalyzed cycloaddition of *N,N*-cyclic azomethine imines with ynones has been reported.

3.2.2.4. Azomethine Ylides. In this field there are two main types of dipoles, pyridinium-type and iminoester-derived ylides.⁴⁵² Pyridinium (**566**), quinolinium (**567**) and isoquinolinium (**568**) salts are precursors of the corresponding azomethine ylides **569-571**, respectively, which are able to undergo 1,3-dipolar cycloaddition with alkynes affording indolizidines and benzoindolizidines (Scheme 254).

Scheme 254. Azomethine Ylides 569-571 Derived from Pyridinium, Quinolinium and Isoquinolinium Salts 566-568

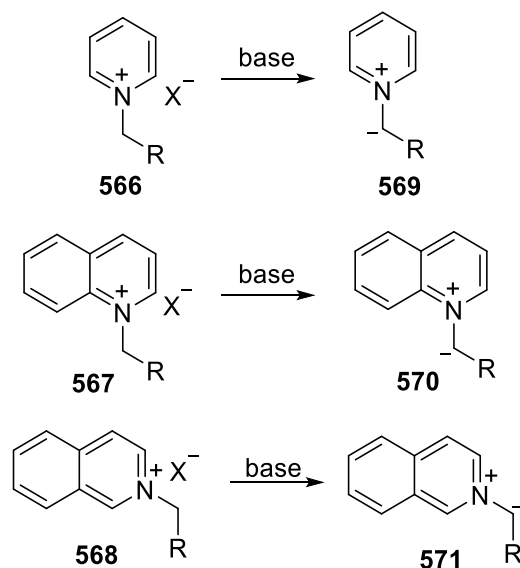

Caira and co-workers⁴⁵³ have described the three-component synthesis of pyrrolo[1,2-*a*]quinoline derivatives (**572**) by reaction of quinoline with phenacyl bromides and ynones **71** in the presence of propylene oxide. In these processes quinolinium salts **567** ($R = \text{PhCO}$) were generated and the bromide opens the epoxide giving the corresponding alkoxide, which acted as a base generating ylides **570**. These ylides underwent 1,3-dipolar cycloaddition with ynones **71** giving the dihydropyrroloquinolines (**572**) (Scheme 255).

Scheme 255. Three-Component 1,3-Dipolar Cycloaddition Involving Quinoline, Phenacyl Bromides and Ynones 71

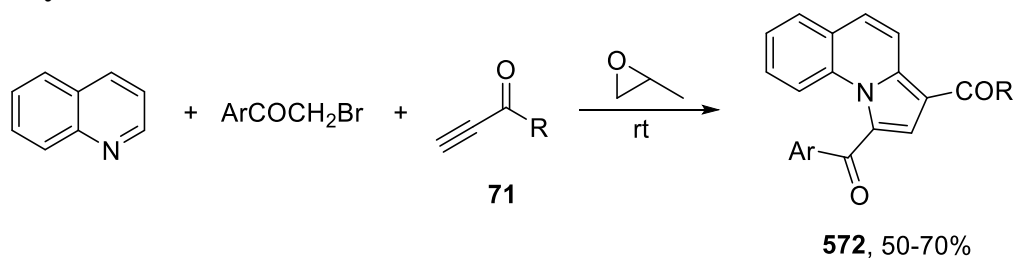

$R = \text{Me, Ph}$

$\text{Ar} = \text{Ph, 4-MeC}_6\text{H}_4, 4\text{-ClC}_6\text{H}_4, 4\text{-FC}_6\text{H}_4, 2\text{-O}_2\text{NC}_6\text{H}_4, 3\text{-O}_2\text{NC}_6\text{H}_4$

Pyridinium ylides **569** generated from the corresponding pyridinium salts **566** have also been used as dipoles by Cossy and co-workers⁴⁵⁴ in the dipolar cycloaddition with ynones **573** for the preparation of 2-aminoindolizidines (**574**) (Scheme 256). The ynones were prepared by oxidation of the corresponding propargylic alcohols with MnO_2 in dichloromethane at room temperature. The [3+2] cycloaddition took place in DMF at room temperature in moderate overall yields from the corresponding alcohols.

Scheme 256. 1,3-Dipolar Cycloaddition of Pyridinium Ylides 566 with Ynones 563

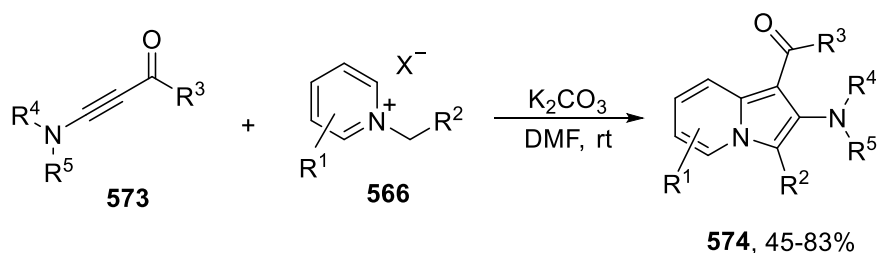

X = Cl, Br, I

R¹ = H, 3,5-Me₂C₆H₃

R² = PhCO, MeCO, 2-PyCO, CO₂Me

R³ = Me, 2-BrC₆H₄, 3-Py(CH₂)₂, BnOCH₂, Me₂C=CH(CH₂)₂CMeCH₂

R⁴ = Boc, Ts

R⁵ = Bn, cPrCH₂, Ph

Müller and co-workers have synthesized indolizines (**575**) by a consecutive one-pot procedure consisting of a coupling/1,3-dipolar cycloaddition sequence of phenacyl bromides, pyridines (to give pyridinium bromides **566**) and *in-situ* generated ynones **71** (from a Pd/Cu-catalyzed coupling of an acyl chloride with terminal alkynes) (Scheme 257).⁴⁵⁵ The *in-situ* formed pyridinium ylides (**569**) provide cycloadducts that are instantaneously aromatized to the highly fluorescent indolizine derivative.

Scheme 257. 1,3-Dipolar Cycloaddition of Pyridinium Ylides **569** with *in-situ* Generated Ynones **71**

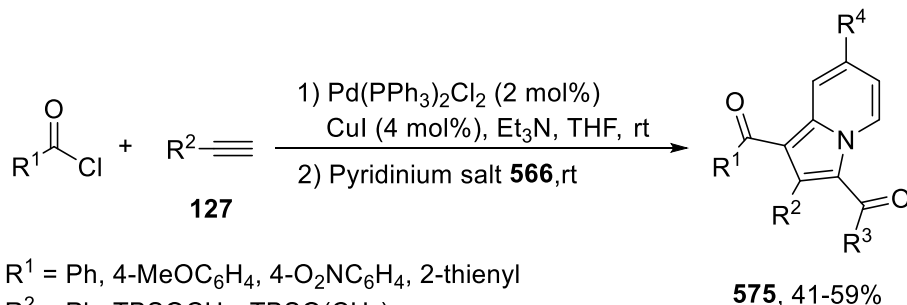

R¹ = Ph, 4-MeOC₆H₄, 4-O₂NC₆H₄, 2-thienyl

R² = Ph, TBSOCH₂, TBSO(CH₂)₄

R³ = EtO, 4-MeOC₆H₄

R⁴ = H, 4-Py

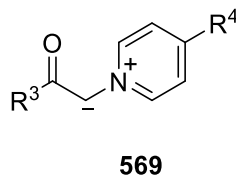
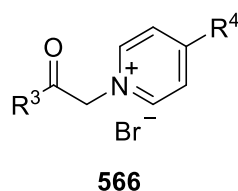

In another three-component reaction, indolizines **575** have been prepared using acetophenones, pyridine (PyH) and ynones **71** via a 1,3-dipolar cycloaddition promoted by iodine.⁴⁵⁶ Phenacyl iodides were generated *in-situ*, which after alkylation of pyridine gave the corresponding pyridinium ylides (**566**), which are able to undergo 1,3-dipolar cycloaddition with ynones **71** in good yields (Scheme 258).

Scheme 258. Iodine-Promoted 1,3-Dipolar Cycloaddition of Pyridinium Ylides **566 with Yrones **71****

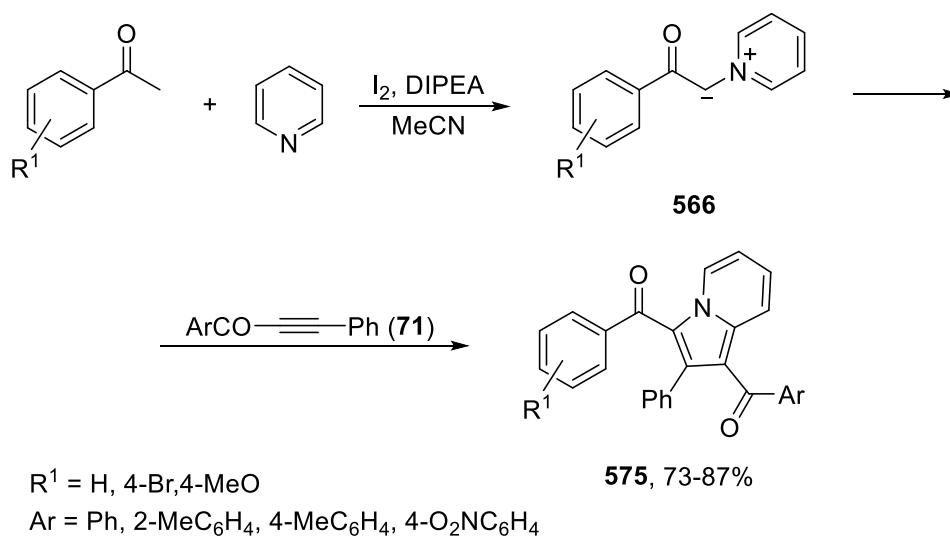

Azomethine ylides generated from imino esters have been widely used in 1,3-dipolar cycloadditions with electron-deficient olefins.⁴⁵² However, only recently the intermolecular 1,3-dipolar addition to yrones was reported, by Tu and co-workers,⁴⁵⁷⁻⁴⁵⁹ who described the asymmetric 1,3-dipolar cycloaddition of yrones with azomethine ylides. A three-component reaction of diethyl amino malonate or α -aryl amino esters **576**, aldehydes and yrones **71**, in the presence of the chiral phosphoric acid **577**, gave the corresponding 2,5-dihydropyrroles **578** in good yields with good enantioselectivities (Scheme 259). According to DFT calculations a step-wise mechanism was operating. First, the Michael addition took place through transition state **I** where **577** acts as a Brønsted-acid and a Lewis-base bifunctional catalyst and affords transition state **II** which leads to the cycloadduct by a Mannich reaction.

Scheme 259. Enantioalyzed 1,3-Dipolar Cycloaddition of Azomethine Ylides from Imino Esters Derived from **576 with Yrones **71** Using Chiral Phosphoric Acid **577****

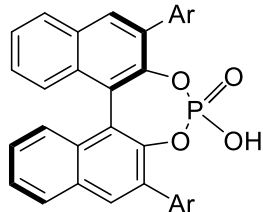
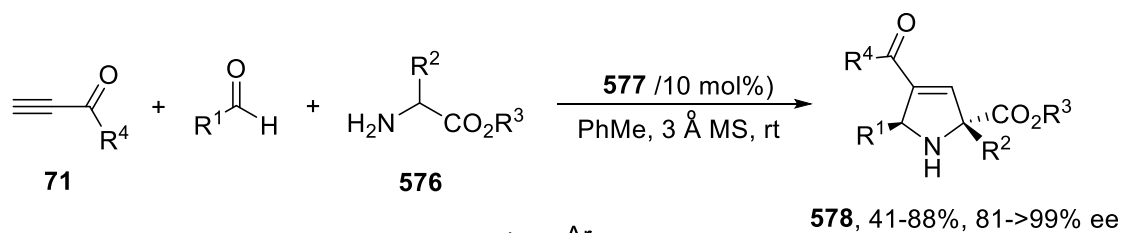
**577** (Ar = 9-anthracenyl)

R¹ = Ph, 2-O₂NC₆H₄, 3-O₂NC₆H₄, 4-O₂NC₆H₄, 4-BrC₆H₄, 4-NCC₆H₄, 4-MeOC₆H₄, 3,4-Cl₂C₆H₃,
 2-naphthyl, 2-thiophenyl, *i*Pr

R² = CO₂Et, Ph, 4-MeOC₆H₄, 4-FC₆H₄, 2-ClC₆H₄, 3-ClC₆H₄, 4-ClC₆H₄, 4-PhC₆H₄

R³ = Me, Et

R⁴ = Me, *n*C₈H₁₇, PhCH₂CH₂, Et₂CH, Cy, *n*Bu, Ph, 2-naphthyl, 3-MeC₆H₄, 4-MeC₆H₄,
 4-MeOC₆H₄, 4-F₃CC₆H₄, 2-FC₆H₄, 4-FC₆H₄, 3,4-F₂C₆H₃, 2-thienyl

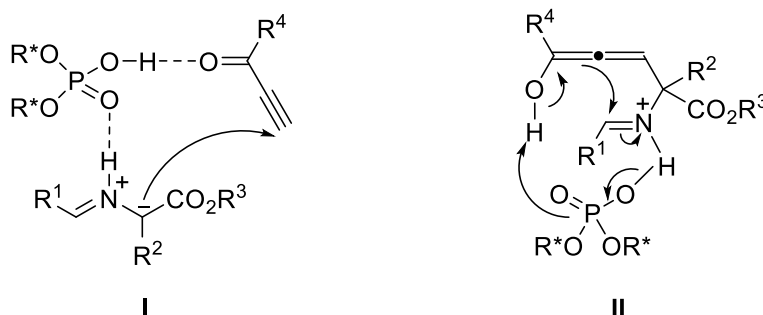

When the 1,3-dipolar cycloaddition between imino esters (**579**) and ynones (**71**) was carried out under AgOAc catalysis, pyrroles (**580**) were formed.⁴⁶⁰ The reaction took place using 20 mol% of the silver salt and 40 mol% of PPh₃ in THF at -40 °C providing the expected pyrroles in moderate to good yields (Scheme 260).

Scheme 260. Ag-Catalyzed 1,3-Dipolar Cycloaddition of Imino Esters (**579**) with Ynones (**71**)

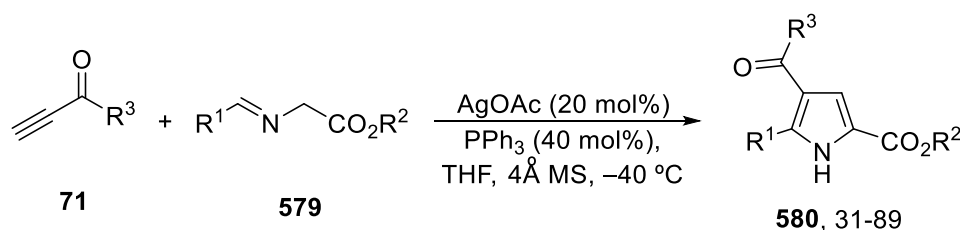

R¹ = Ph, 4-ClC₆H₄, 2-ClC₆H₄, 3-BrC₆H₄, 4-BrC₆H₄, 2-MeC₆H₄, 4-MeC₆H₄, Cy

R² = Me, Et, *t*Bu

R³ = Ph, 4-ClC₆H₄, 4-O₂NC₆H₄, 3-BrC₆H₄, 2-FC₆H₄, 2-MeC₆H₄, 4-MeC₆H₄, 4-MeOC₆H₄,
 2,4-Me₂C₆H₃, 2-furyl

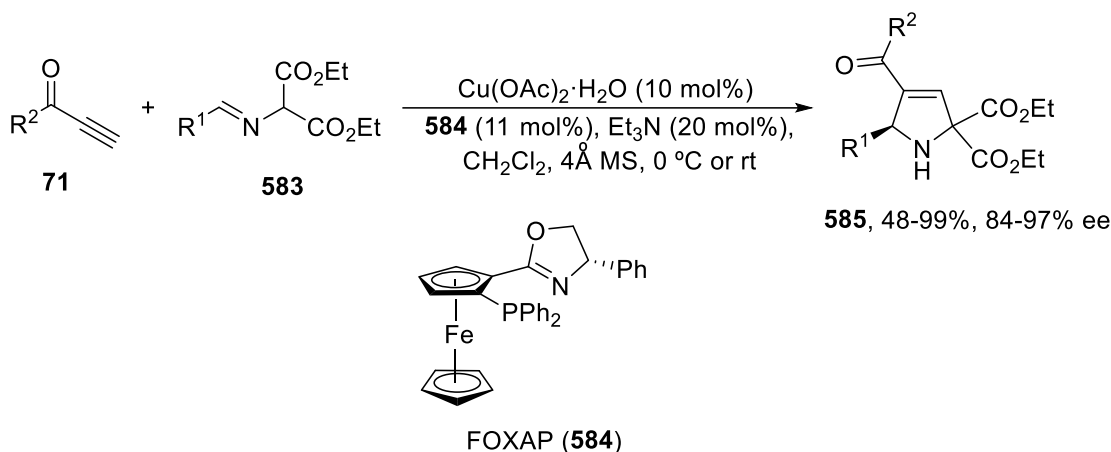

$\text{R}^1 = \text{Ph, 4-MeOC}_6\text{H}_4, 4\text{-BrC}_6\text{H}_4, 3\text{-O}_2\text{NC}_6\text{H}_4, 4\text{-O}_2\text{NC}_6\text{H}_4, 4\text{-NCC}_6\text{H}_4, 3,4\text{-Cl}_2\text{C}_6\text{H}_3, 2\text{-naphthyl, 2-thienyl, } i\text{Pr}$
 $\text{R}^2 = \text{Me, Ph, 4-FC}_6\text{H}_4, 4\text{-MeOC}_6\text{H}_4, 2\text{-naphthyl, 2-thienyl}$

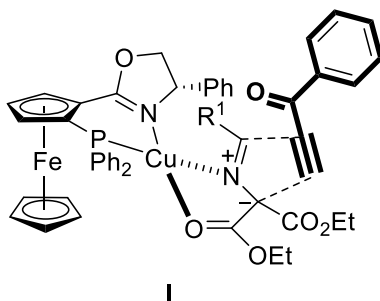

In conclusion, azomethine ylides derived from pyridinium type salts are appropriate dipole precursors for the 1,3-dipolar cycloaddition to ynones giving indolizines. Imino esters are adequate precursors of azomethine ylides which are able to form the corresponding pyrroles by reaction with ynones.

3.2.2.5. Nitrile Oxides. 1,3-Dipolar cycloaddition of nitrile oxides with ynones gave isoxazoles under thermal conditions. This type of propargyl dipoles are usually prepared by *in-situ* dehydrochlorination of α -chloro oximes. Rossi and co-workers⁴⁶³ have performed the 1,3-dipolar cycloaddition of β -(2-aminophenyl)- α,β -ynones (**200**) with *in-situ* generated nitrile oxides (**586**) (Scheme 263). The reaction was performed by adding α -chloro oxime to a boiling xylene or toluene solution of **200** and Et_3N affording isoxazo[4,5-*c*]quinolines (**587**) in moderate yields. The α -chloro oximes were prepared by treating the oximes (derived from benzaldehydes) with *N*-chlorosuccinimide (NCS) in a solution of pyridine in chloroform.

Scheme 263. 1,3-Dipolar Cycloaddition of Nitrile Oxides (587) with Ynones (200)

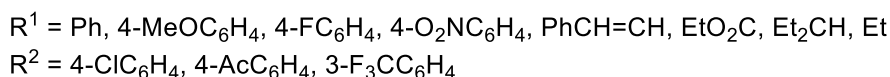
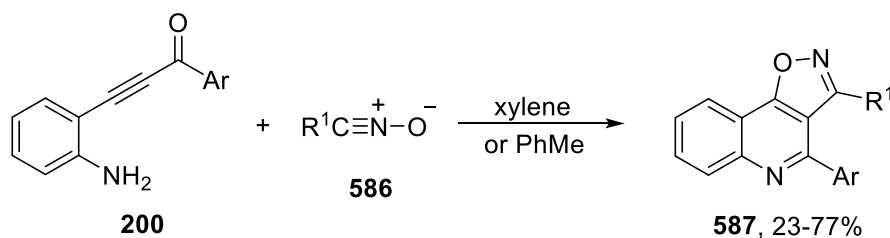

Müller and co-workers⁴⁶⁴ have reported a microwave-assisted 1,3-dipolar cycloaddition of nitrile oxides with ynones. The ynones were prepared by Pd-catalyzed Sonogashira coupling of acyl chlorides with terminal alkynes **127** as previously reported in Section 2.2.2.1. Subsequently α -chloro oximes and triethylamine were added and heated at 90 °C under MW irradiation (Scheme 264). The resulting isoxazoles (**588**) were obtained in variable yields in only 30 min, whereas 2-4 days were necessary to complete the reaction with conventional heating.

Scheme 264. 1,3-Dipolar Cycloaddition of *in-situ* Generated Nitrile Oxides (586) with Ynones under MW Irradiation

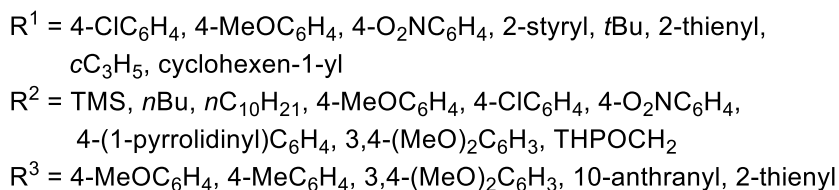
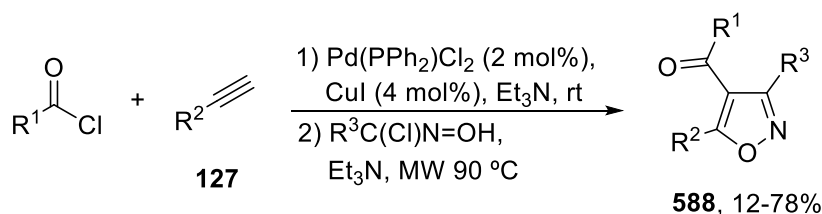

3.2.2.6. Diazo Compounds. Anions derived from diazo compounds are very reactive dipoles able to form pyrazolines by reaction with alkenes as dipolarophiles. Dimethyl (diazomethyl) phosphonate, known as the Seyferth-Gilbert reagent, can be deprotonated giving the corresponding anion. This anion can be generated by basic methanol-promoted deacylation of dimethyl 1-diazo-2-oxopropyl phosphonate (**589**), known as the Bestmann-Ohira reagent (BOR). BOR acted as dipole in 1,3-dipolar cycloaddition with dipolarophiles giving phosphonylated heterocycles. Rastogi and co-workers⁴⁶⁵ have studied the reactivity of BOR with ynones **71** using methanolic KOH at room temperature and obtained 3-carbonyl pyrazole-5-phosphonates **590** in high yields (Scheme 265). The proposed reaction mechanism involves deacylation of **589** generating anion **I** that undergoes a formal 1,3-dipolar cycloaddition with ynone **71** and form allenyl anion **II**. Rearrangement of **II** gives intermediate **III**, which is converted to **590** by proton migration.

The TZC was applied by Fu and co-workers⁴⁶⁷ to synthesize diquinanes from ynones **593** and **594** (Scheme 267). Under slightly modified conditions (20 mol% of *n*Bu₃P in a 9:1 mixture of dichloromethane/ethyl acetate under more dilute conditions (0.01 M), the ynones gave bicyclo[3.3.0]octan-2-one derivatives **595** and **596**, respectively, in good yields with a high diastereomeric ratio (>20:1). They also developed an asymmetric version using a chiral phosphine (**597**), which afforded **595** (R¹ = Ph, R² = H, R³ = Et) in moderate yield with moderate enantioselectivity.

Scheme 267. Intramolecular [3+2] Annulation of Ynones **593 and **594** under Phosphine Catalysis**

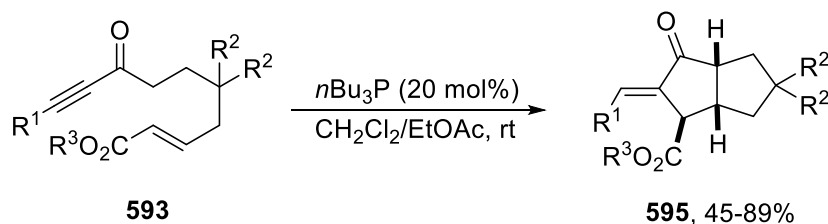

R¹ = Ph, 2-MeO-6-naphthyl, *c*C₆H₁₁, cyclohex-1-enyl, *n*Bu, Me
 R² = H, CO₂Et
 R³ = Me, Et

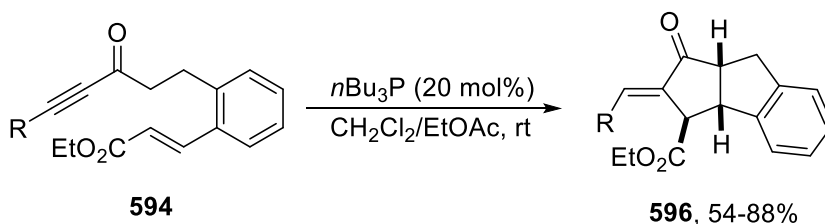

R = *n*C₅H₁₁, Ph

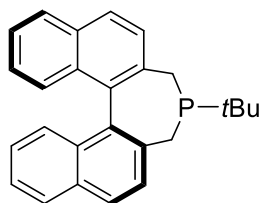
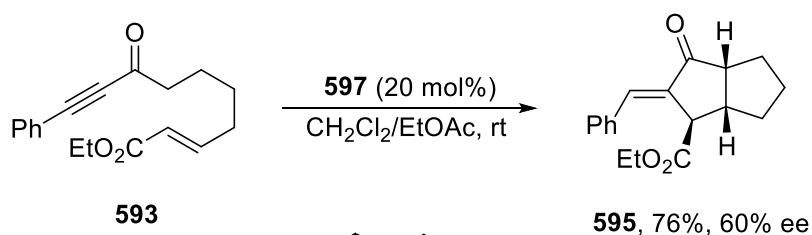

597

Intramolecular cycloadditions of ynones **71** with *N*-tosylimines (**598**) are initiated by a Michael addition of tri-*n*butylphosphine to the ynones followed by a Mannich reaction to the imine and final attack of the nitrogen anion to the vinylphosphonium cation

involving intermediates **I-V** (Scheme 268).⁴⁶⁸ This [3+2] annulation was carried out using 20 mol% of *n*Bu₃P in toluene at room temperature affording pyrrolines (**599**) in very good yields.

Scheme 268. [3+2] Annulation of *N*-Tosylimines (598**) with Yrones **71** Catalyzed by *n*Bu₃P**

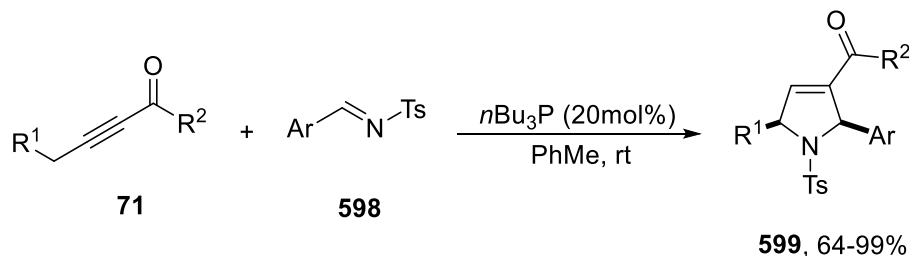

Ar = Ph, 4-BrC₆H₄, 4-ClC₆H₄, 4-FC₆H₄, 3-O₂NC₆H₄, 4-O₂NC₆H₄, 4-MeC₆H₄,
4-MeOC₆H₄, 2-ClC₆H₄, 2-BrC₆H₄, 3,4-Cl₂C₆H₃, 4-Me-3-O₂NC₆H₄,
1-naphthyl, Ph(CH₂)₂

R¹ = *n*Pr, *n*C₅H₁₁

R² = Ph, 4-BrC₆H₄, 4-ClC₆H₄, 4-FC₆H₄, 4-O₂NC₆H₄, 4-MeC₆H₄, 4-MeOC₆H₃,
1-naphthyl, 2-furyl, 2-thienyl

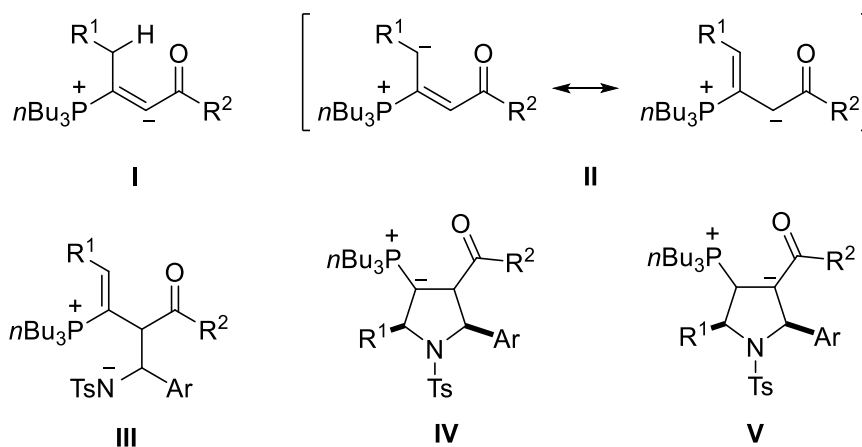

Shi and co-workers^{469,470} described the phosphine PhEt₂P-catalyzed [3+2] annulation of isatins (**600**) with yrones **71** giving spiro[furan-2,3'-indoline]-2',4(*5H*)-diones (**601**) at room temperature with good yields. The asymmetric [3+2] annulation has been performed with 20 mol% of the chiral phosphine (4*S*,5*S*)-4,5-bis[(diphenylphosphino)methyl]-2,2-dimethyl-1,3-dioxolane (DIOP, **602**).⁴⁷¹ *N*-Protected isatins reacted with but-3-yn-2-one in ether at -20 °C to give **601** with ee up to 90% (Scheme 269). On the other hand, using 100 mol% of DABCO a [3+2] annulation took place giving spiro[indoline-3,2'-pyran]-2,4'(3'*H*)-diones.

Scheme 269. Asymmetric [3+2] Annulation of Isatins (600**) with Ynone **71** Catalyzed by DIOP (**602**)**

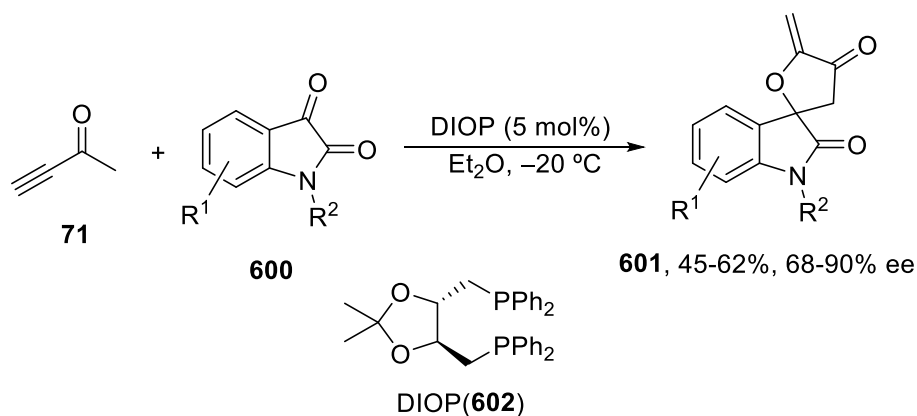

R¹ = H, 5-F, 5-Cl, 5-Br, 5-I, 5-Me, 5-MeO, 6-Cl, 6-Br, 6-Me, 5,7-Me₂

R² = Me, CH₂=CHCH₂, Bn, 9-anthracenylmethyl

The same reaction of isatins **600** was independently described by Huang and co-workers,⁴⁷² who used different ynones **71** and another phosphine (10 mol% diphenylmethylphosphine) but obtained **601** in 51-94% yield. Recently, the same group has described a [3+2] annulation of 2-arylideneindane-1,3-diones (**603**) with ynones **71**, catalyzed by Ph₃P (30 mol%) and benzoic acid (30 mol%) in EtOH at room temperature, and reported formation of spirocyclopentanones **604** in high yields (Scheme 270).⁴⁷³ In the proposed mechanism, initial formation of dipole **I** by a Michael addition of PPh₃ to the ynone was postulated, and this dipole, after a proton shift (mediated by PhCO₂H and EtOH), produces enolate **II**, which adds to **603** and forms intermediate **III**, the precursor of the final product **604**.

Scheme 270. [3+2] Annulation of 2-Arylideneindane-1,3-diones **603** with Ynones **71** Catalyzed by Ph₃P and PhCO₂H

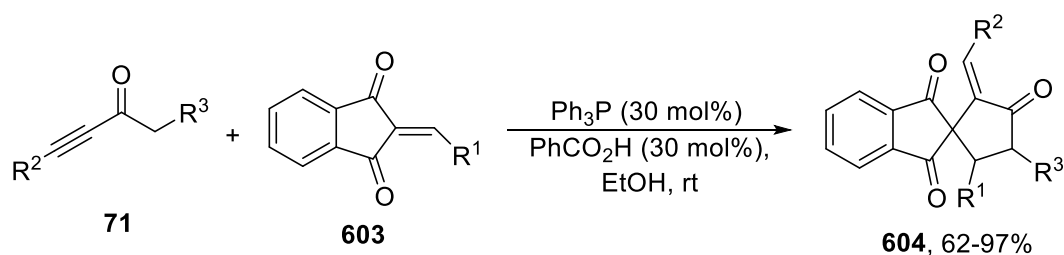

R¹ = Ph, 2-BrC₆H₄, 3-BrC₆H₄, 4-BrC₆H₄, 2-MeC₆H₄, 3-MeC₆H₄, 4-MeC₆H₄, 4-ClC₆H₄, 4-FC₆H₄, 4-MeOC₆H₄, 4-O₂NC₆H₄, 2,4-Cl₂C₆H₃, 2-furyl, 2-thienyl, 1-naphthyl, styryl
 R² = Ph, 4-FC₆H₄, 4-MeC₆H₄, *n*Bu
 R³ = H, Me

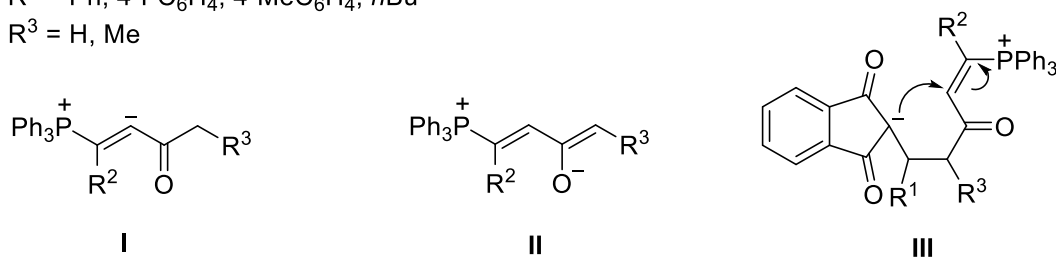

When alkyldieneoxindoles (**605**) were allowed to react with ynones **71** catalyzed by phosphines, the corresponding five-membered spiroxindoles were obtained (Scheme

271).⁴⁷⁴ This [3+2] phosphine-catalyzed TZC gave a mixture of ketoamides **606** or **607** using Ph_3P (20 mol%) and 4-phenylbut-3-yn-2-one (**71**), the corresponding diastereoselectivity being dependent from the substituents in **605**. When other ynones were reacted with **605** ($\text{R}^1 = \text{R}^2 = \text{CN}$) using $(4\text{-FC}_6\text{H}_4)_3\text{P}$ (20 mol%), the corresponding spirooxindoles **606** were obtained with good yields.

Scheme 271. [3+2] Annulation of 3-Alkylideneoxindoles (605**) with Ynones **71** Catalyzed by a Phosphine**

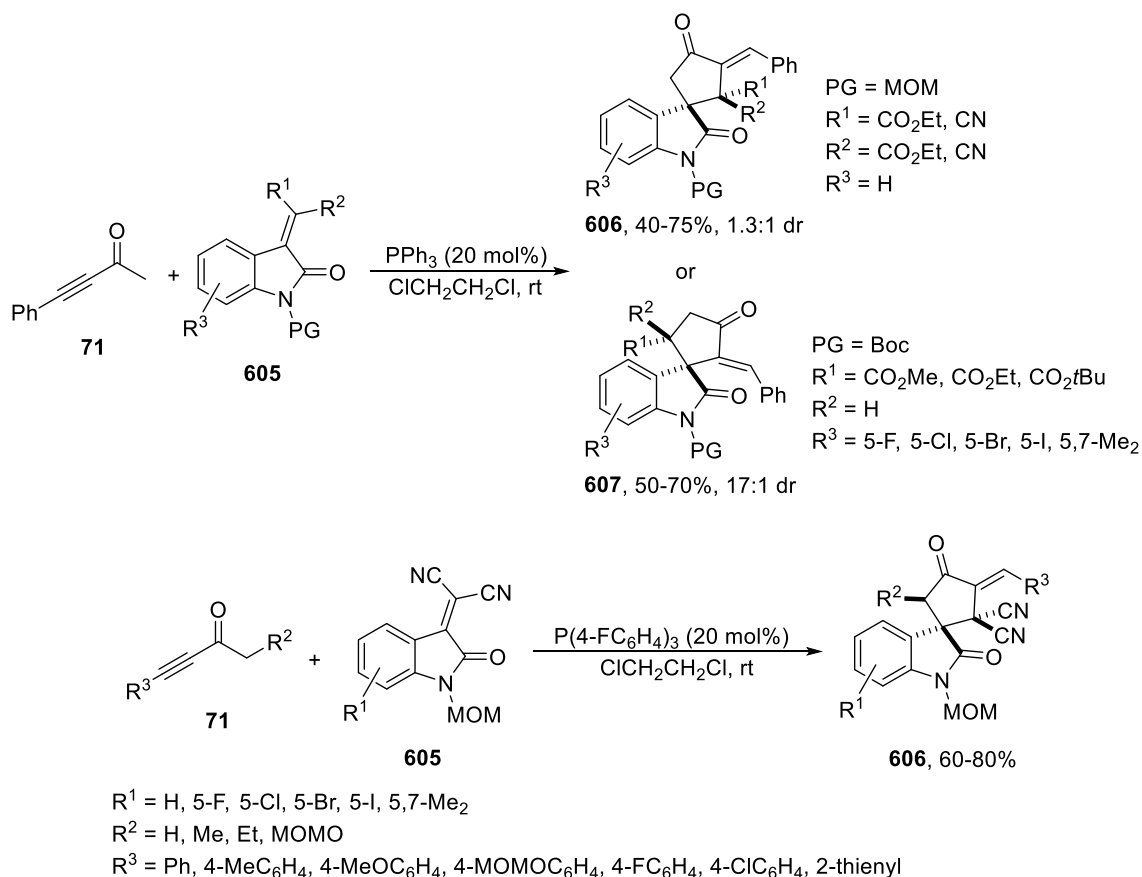

In conclusion, phosphine-catalyzed intra- and intermolecular annulation reactions of ynones with different electrophiles give the corresponding five-membered rings.

3.2.3. [4+2] Cycloadditions. The ability of conjugated ynones to undergo Diels-Alder reactions has been known and utilized for decades. A number of basic studies, many carried out with but-3-yn-2-one and dibenzoyl acetylene in particular, have been reviewed,⁴⁷⁵⁻⁴⁷⁷ and so have some of the applications of the reaction in natural-product synthesis.⁴⁷⁸⁻⁴⁸⁰ The knowledge described in these publications and references cited therein have been applied and developed further in recent years and made Diels-Alder reactions with α,β -unsaturated ynones a more powerful tool in organic synthesis.

When ynones undergo Diels-Alder reactions, the primary products will be 1,4-cyclohexadienes, which exhibit substituent-dependent stability. Stable products (**608**) were obtained by Yamamoto and Payette when four ethyl and phenyl 2-silylethynyl

ketones (**71**) were reacted with various cyclic and acyclic dienes in the presence of a chiral oxazaborolidinium catalyst (**609**).⁴⁸¹ In all cases the adducts were isolated in good to excellent yield as a single regioisomer with 99% ee (Scheme 272). The fact that 1-phenylprop-2-yn-1-one exhibits the same regioselectivity as the 1-silylated analog and furnishes the analogous regioisomer in 90% yield with 99% ee clearly demonstrates that the silyl group is not essential to achieve high reactivity and chiral induction. Finally, it should be mentioned that cyclopentadiene gives adducts (**610**) with a lower ee than the other dienes, but the ee (71-74%) was significantly improved when TMS was replaced with the larger *tert*-butyldimethylsilyl (TBS) group (90-95%), yields being in all cases higher than 88% (Scheme 273).⁴⁸¹

Scheme 272. Asymmetric Diels-Alder Reaction of Phenyl 2-Trimethylsilylethynyl Ketones (71**) with Various Dienes**

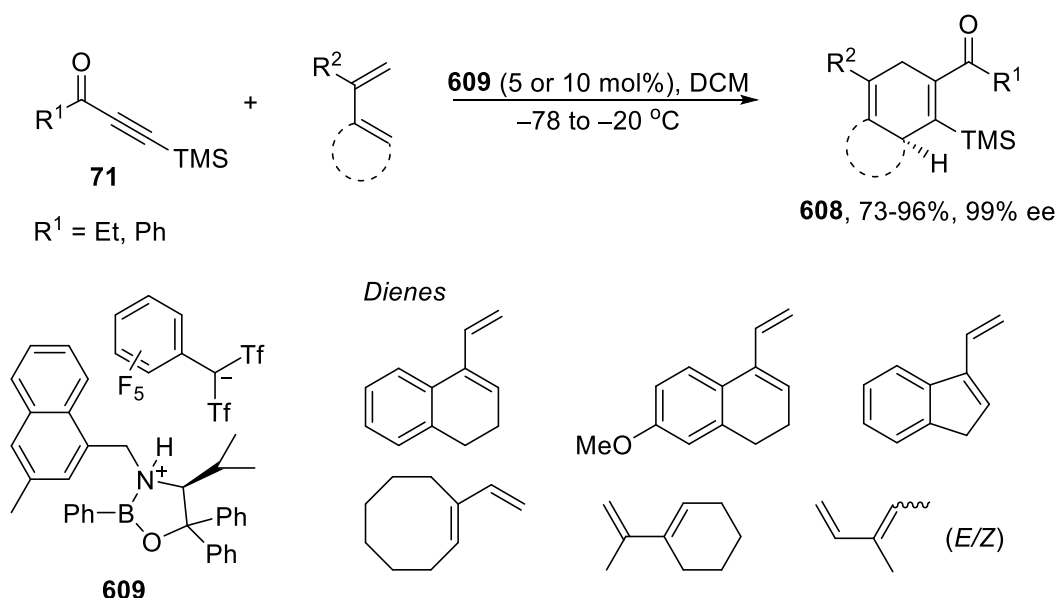

Scheme 273. Asymmetric Diels-Alder Reactions of β -Silyl Ynones (71**) with Cyclopentadiene**

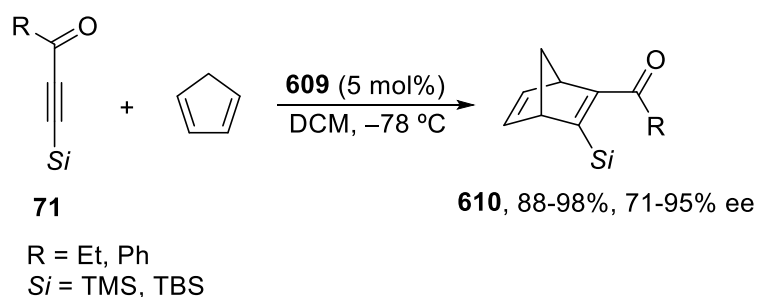

Stable adducts were also formed when Siegel and coworkers, in their synthesis of xanthofulvin and vinaxanthone, reacted *tert*-butyl 4-oxopent-2-ynoate (**71**, $\text{R} = \text{CO}_2t\text{Bu}$) with furan **611** and obtained 7-oxobicyclo[2.2.1]hepta-2,5-dienes (**612** and **613**) in

excellent yield with high regioselectivity (>20:1) (Scheme 274).³⁹⁹ The high selectivity was ascribed to the high polarization of the diene combined with the predominant ketone activation of the triple bond.

Scheme 274. Reaction of Ynone 71 with Furan 611, a Key Step in the Synthesis of 5,6-Dehydropolivione

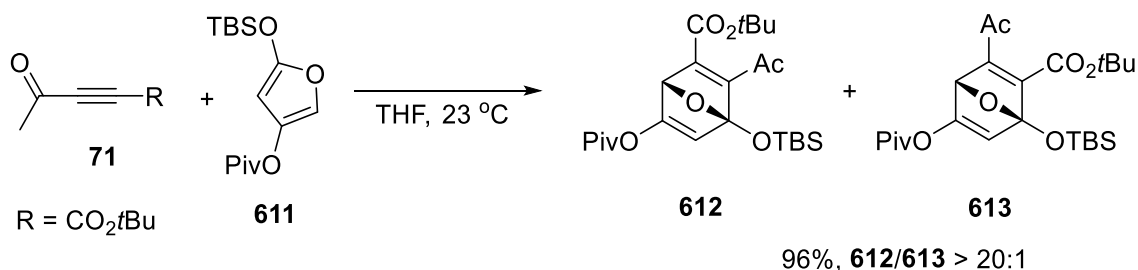

Efficient Diels-Alder reactions took also place when a series of 1-aryl-3-trimethylsilylprop-2-yn-1-ones (**71**) were reacted with 2,3-dimethyl-1,3-butadiene in the presence of a Lewis acid, preferably BCl₃.⁴⁸²⁻⁴⁸⁴ However, in most cases the aryl 4,5-dimethyl-2-trimethylsilylcyclohexa-1,4-dienyl ketones (**614**) formed were unstable under the reaction conditions and underwent quickly the Nazarov reaction which generated [6-5-6] tricyclic products (**615**) in good yields (Scheme 275).⁴⁸² The presence of the silyl group was important for the outcome, because in its absence, the Nazarov reaction did not take place, the product being the expected cycloadduct **616** (yield not reported).⁴⁸² This observation is in accordance with involvement of cationic intermediates **I** and **II**, of which **II** benefits from significant β-silyl stabilizing effect. Chalifoux and co-workers have also studied the reaction between some cross-conjugated diyrones (**617**) and some 1,3-butadienes. When there was a silyl group at one or both C-β atoms, non-aromatic [6-5-6] tricyclic products **618** were formed via cation intermediates **I** and **III** and subsequent loss of a silyl group.^{483,484} It is also noteworthy that the outcome was quite sensitive to the nature of the Lewis applied: many gave no cyclic product at all and some R_nAlCl_(3-n) compounds appeared to give somewhat better results than BCl₃.⁴⁸³

Scheme 275. Tandem Diels-Alder/Nazarov Reaction Between Yrones 71 and 617 and 1,3-Butadienes

in a regiospecific manner (Scheme 276).⁴⁸⁵ The target macrocycles **623**, containing a 5-membered ring and a 14-membered ring with a paracyclophane, were then obtained in a retro-Diels-Alder upon heating the dried macrobeads in the absence of solvent at 110 °C.

Scheme 276. Diels-Alder Reaction of Steroids 621 with Ynones 71

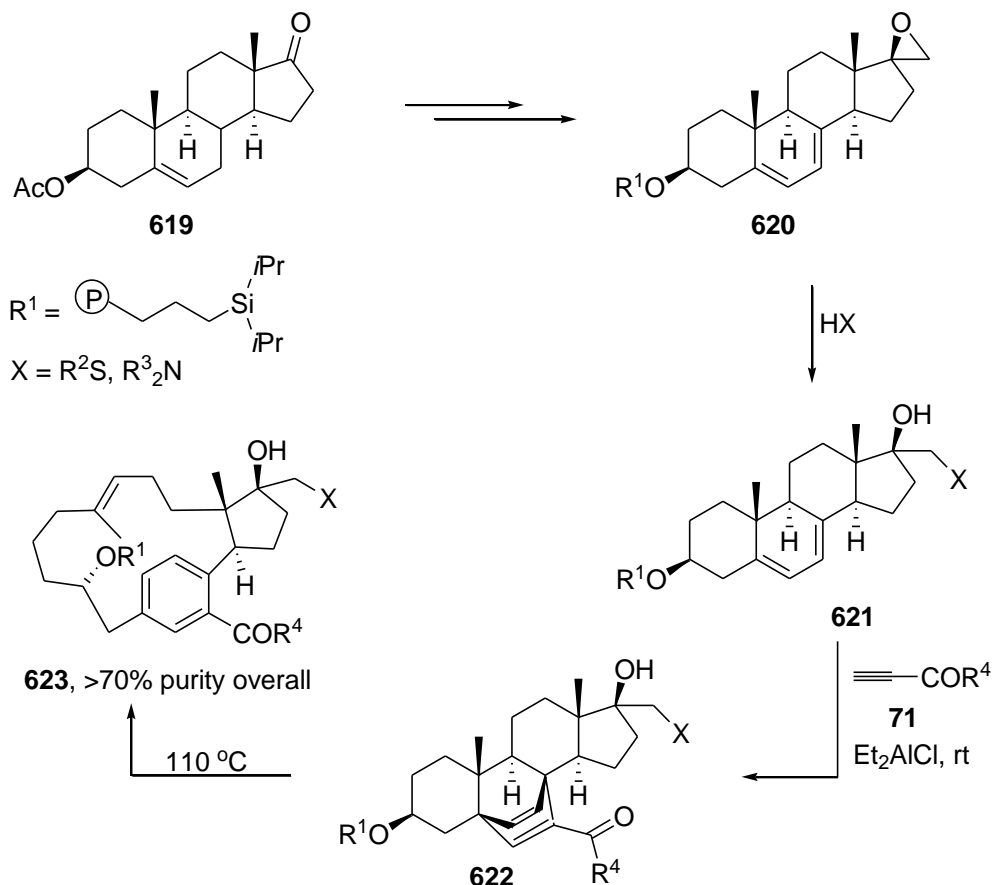

Unlike 1,4-cyclohexadienes, bicyclo[2.2.2]octa-2,5-dienes **624** formed when 2-(2-bromo-6-nitrophenyl)ethynyl ketones **129** were reacted with 1-methoxy-1,3-cyclohexadiene, were not isolated because they decomposed at the reaction temperature (130 °C).¹¹⁹ However, the decomposition of adducts **624** was a clean process and the corresponding 2,2',6,6'-tetrasubstituted biphenyls (**625**) were formed in good yields by extrusion of ethene (Scheme 277).¹¹⁹

Scheme 277. Diels-Alder Reaction of Ynones 129 with 1-Methoxycyclohexa-1,3-diene

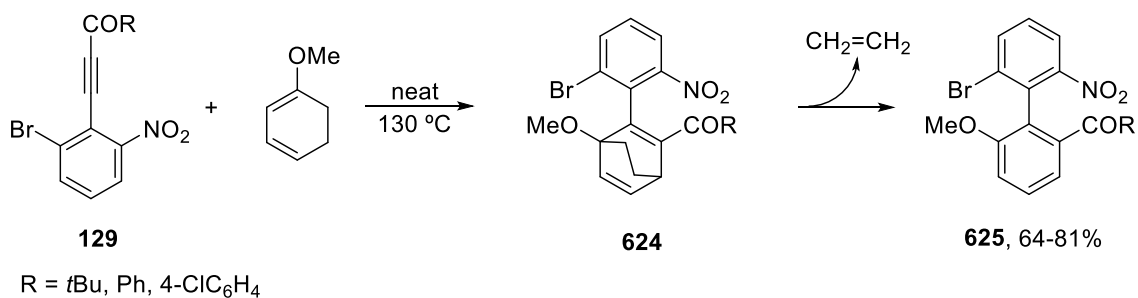

The lability of a Diels-Alder adduct was also instrumental in the synthesis of antibiotics cadiolide A, B, and D by Boukouvala and Thibault.⁴⁸⁷ When 1,3-bis(4-methoxyphenyl)prop-2-yn-1-one (**71**) was heated with an excess of 5-ethoxy-4-methyloxazole (**626**) in ethylbenzene, a regioselective cycloaddition furnished mainly bicyclic adduct **627**, which underwent a retro-Diels-Alder reaction and formed mainly furan **628** by acetonitrile extrusion (Scheme 278). The product mixture was not purified but treated directly with aqueous HBr/THF to give mainly butenolide **629** in 70% yield.⁴⁸⁷

Scheme 278. Diels-Alder Reaction of Ynone 71 with 5-Ethoxy-4-methyloxazole (626)

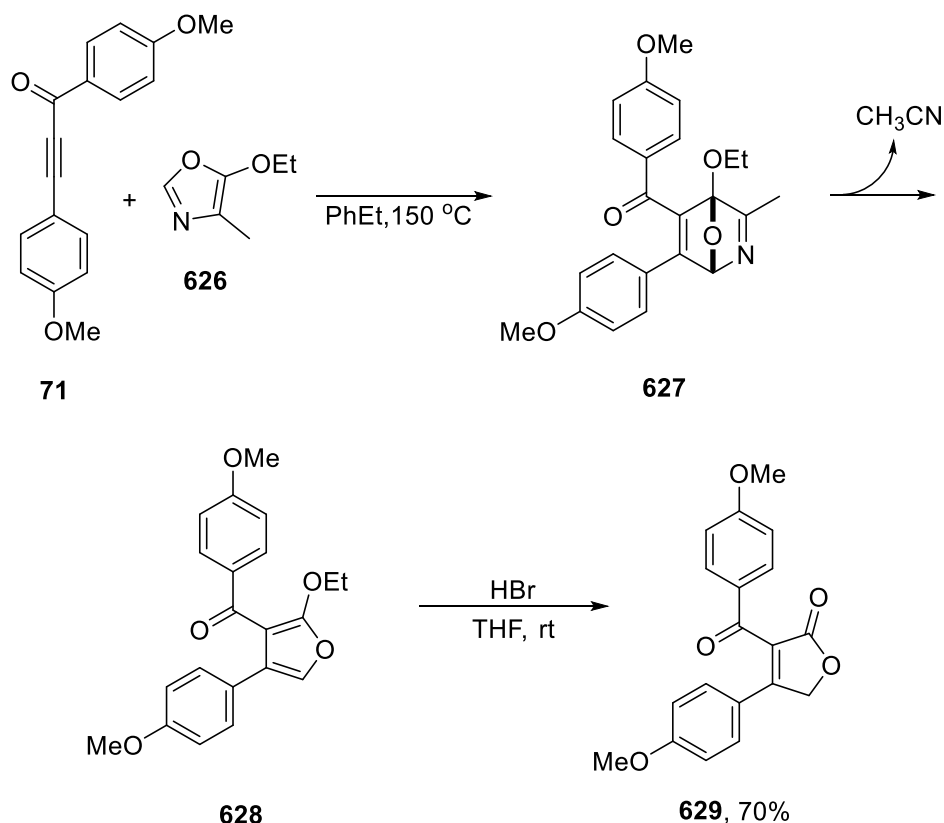

An ynone applied as dienophile by Kalinin and co-workers is ethyl 4-chloro-2-oxobut-3-ynoate (**143**), which appeared to undergo Diels-Alder reactions with different dienes at room temperature yielding adducts **630-635**.¹³⁰ Yields above 75% were obtained in most cases provided long reaction times were used (Scheme 279). Reaction with anthracene

failed under these conditions, but when stannic chloride was added as catalyst, adduct formation across the middle ring took place and gave the expected product (**633**) in 79% yield.

Scheme 279. Diels-Alder Reactions with Acetylenic Ketoester 143

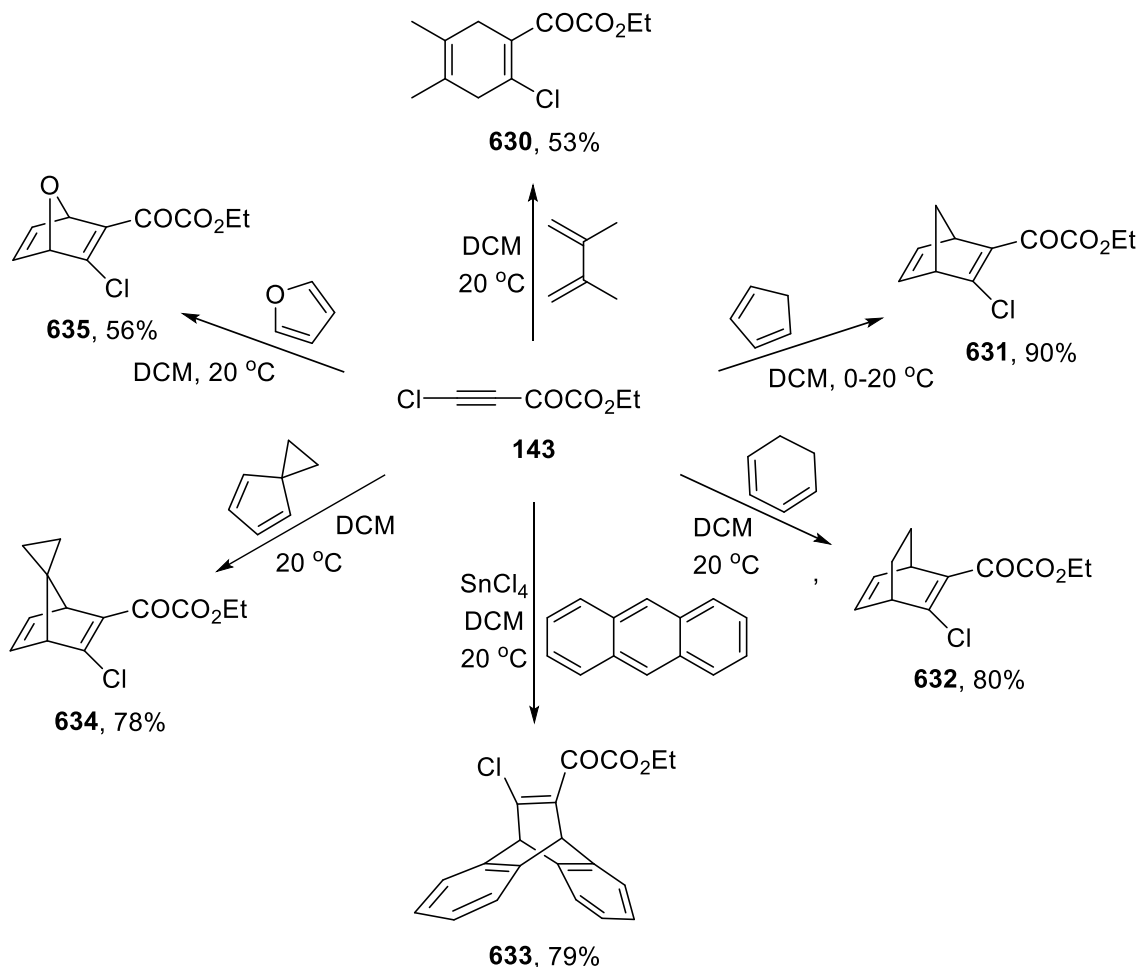

When a number of ethyl 2-oxobut-3-ynoates, containing TMS or an aryl group at C4 instead of a chlorine atom, were reacted with Danishefsky's diene under copper(II) catalysis, the course of the reaction changed completely and tetrasubstituted dihydropyrans were obtained instead by a hetero-Diels-Alder reaction⁴⁸⁸ (Section 3.2.4.).

An intramolecular Diels-Alder reaction is instrumental in Uang and co-workers' synthesis of (-)-pterosin N (**636**).⁴⁰ When the chiral acetylenic 1,3-dienyl hydroxyketone **40** was stirred in toluene containing some 2,6-di-*tert*-butyl-4-methylphenol (BHT) for 2 days, a Diels-Alder reaction occurred and afforded the expected adduct (Scheme 280). This compound was not isolated, but treated directly with 2,3-dichloro-2,3-dicyano-1,4-benzoquinone (DDQ), which removed the *p*-methoxybenzyl (PMB) protection, aromatized the cyclohexadiene ring, and afforded natural product **636** in 41% yield over the two steps.

Scheme 280. Completion of the Synthesis of (-)-Pterosin (636) by an Intramolecular Diels-Alder Reaction Involving the Ynone 40

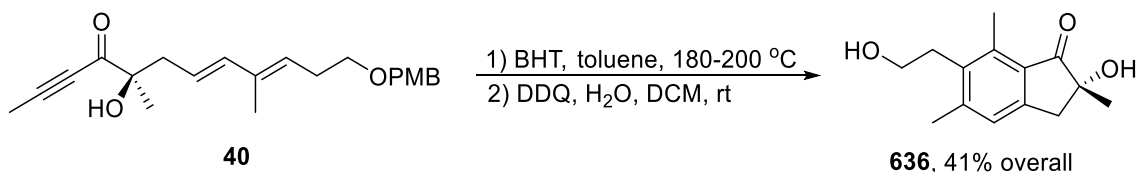

Finally, Siegel and co-workers⁴⁸⁹ utilized the ability of derivatives of 3-(3-oxobut-1-ynyl)coumar-4-one (**454**) to function as a dienophile in [4+2] cycloaddition in the synthesis of a variety of vinaxanones, natural products which prevent growth cone collapse.⁴⁰⁰ Dienes **637**, tautomers of **460**, were in fact generated from **454** by a hydration/ring-opening/conjugate-addition/enolization cascade of reactions in an aqueous mixture of NEt₃ and acetonitrile (Section 3.1.3.), and when reacting with **454** in Et₃N/MeCN, the Diels-Alder reaction occurred in a regioselective fashion and protected derivatives of the desired vinaxanones **638** were obtained in up to excellent yield (Scheme 281), after global deprotection using boron trichloride. In total 15 vinaxanones were synthesized in moderate to excellent yield following this strategy.

Scheme 281. Diels-Alder Reaction of Ynones 454 with Dienes 637

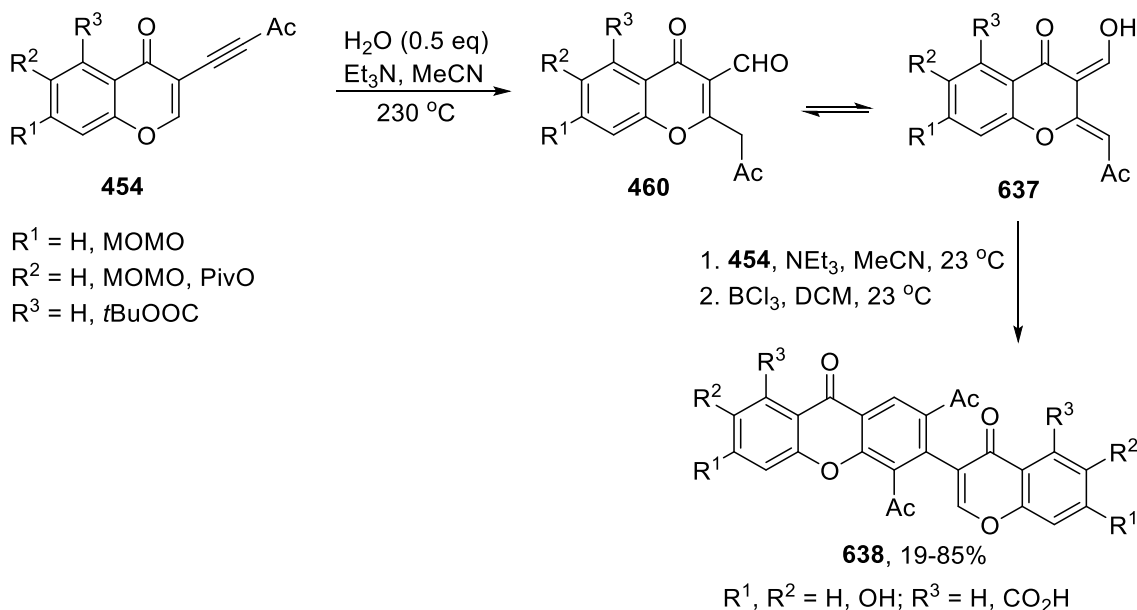

In conclusion, ynones undergo Diels-Alder reactions with a range of dienes giving cyclohexa-1,4-dienes in moderate to excellent yields. Most of the reactions are intermolecular and involve cyclic dienes. When heated above 100 °C, many of the adducts turn out to decompose and form aromatic compounds by extrusion.

3.2.4. Other Cyclizations. We will divide this section in two parts, the first devoted only to carbocyclizations and the second to heterocyclizations leading to heterocyclic compounds.

3.2.4.1. Carbocyclizations.⁴⁹⁰ Most of these reactions are intramolecular processes, but there are also some intermolecular reactions. Taylor and co-workers reported the total synthesis of spirobacillene A, the key step being the cyclization of ynone **639** to spirocompound **640** promoted by iodine (Scheme 282).⁴⁹¹ In this cyclization the iodonium cation **I** was postulated to promote the product formation.

Scheme 282. Spirocyclization of Ynone 639 to give Compound 640

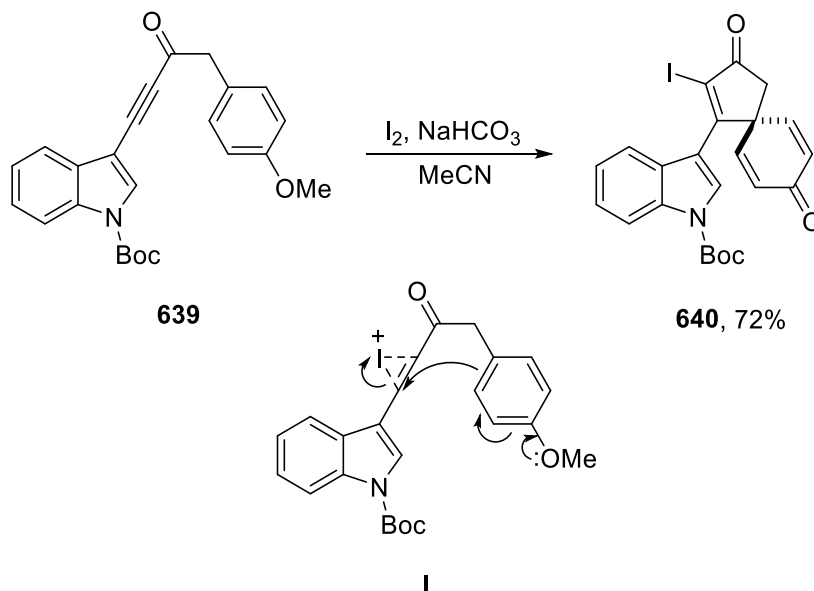

The same transformation (**639**→**640**) has been carried out by the same research group using three different methodologies, namely (1) *Method A*: $SnCl_2 \cdot H_2O$; (2) *Method B*: $Cu(OTf)_2$; and (3) *Method C*: $AgNO_3 \cdot SiO_2$, in all cases in CH_2Cl_2 at room temperature, so starting materials **71** were transformed into spirocompounds **641** under mild reaction conditions (Scheme 283).⁴⁹² When the starting materials were **642**, *Method C* gave products **643**.

Scheme 283. Conversion of Ynones into Spirocompounds

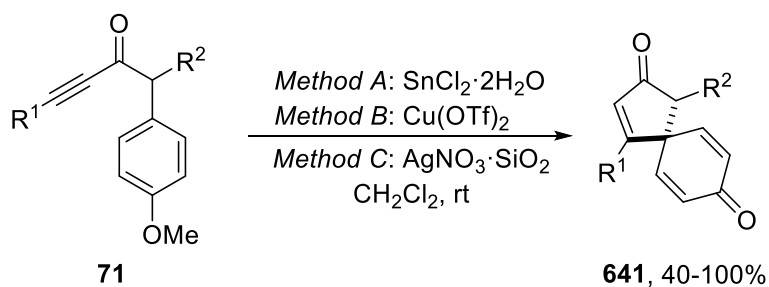

R¹ = *n*Bu, MeNBoc(CH₂)₂, TBSO(CH₂)₂, *c*C₃H₅, *c*C₅H₉, Ph,
 4-MeOC₆H₄, 4-Me₂NC₆H₄, 2-thienyl
 R² = H, Et

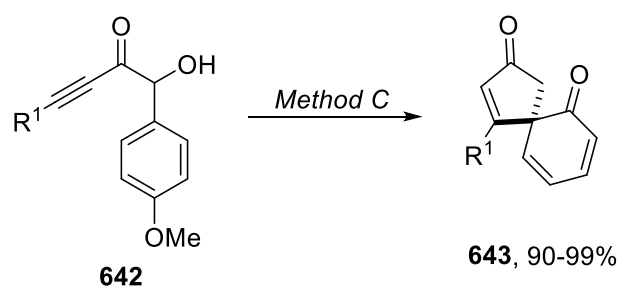

R¹ = *c*C₃H₅, Ph, 4-MeOC₆H₄, 4-FC₆H₄

Zhang and co-workers reported a photoinduced dehydro-Diels-Alder reaction^{493,494} of ynones **71**, **644** and **645** to give the corresponding naphthalene derivatives **646-649** (Scheme 284). In all cases a diradical of type **I** (generated after a $n \rightarrow \pi^*$ excitation followed by a $S_1 \rightarrow T_1$ intersystem crossing) has been proposed to explain mechanistically the obtained results.⁴⁹⁵

Scheme 284. Preparation of Compounds 646-649 by Photochemical Activation of Ynones 71, 644 and 645

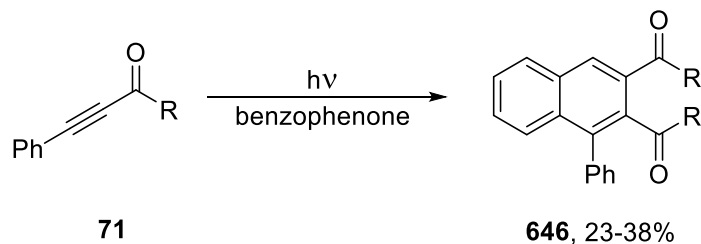

R = Me, Et, *n*Pr, Ph

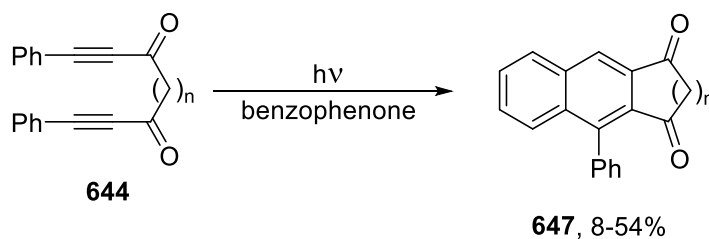

n = 2-4, 8

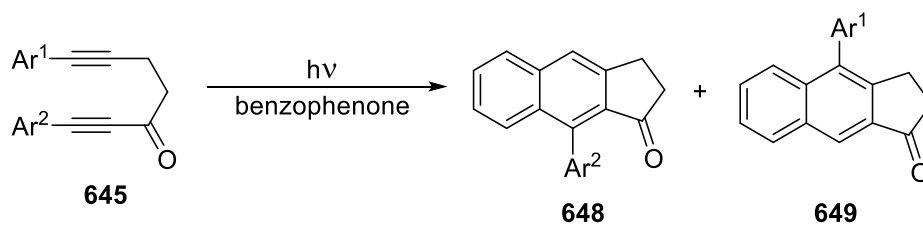

Ar¹ = Ph, 4-MeOC₆H₄, 4-ClC₆H₄, 4-F₃CC₆H₄

Ar² = Ph, 4-MeOC₆H₄, 4-ClC₆H₄, 4-F₃CC₆H₄

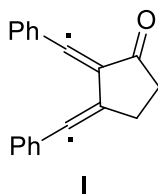

Wessig's group has studied the photoinitiated reaction between ynones **71** and arylacetylenes **127** to give mainly diaryls **650** (Scheme 285).⁴⁹⁶ Also in this case a diradical of type **I** is believed to take part in the process.

Scheme 285. Photoinduced Cross Coupling of Ynones **71 with Acetylenes **127****

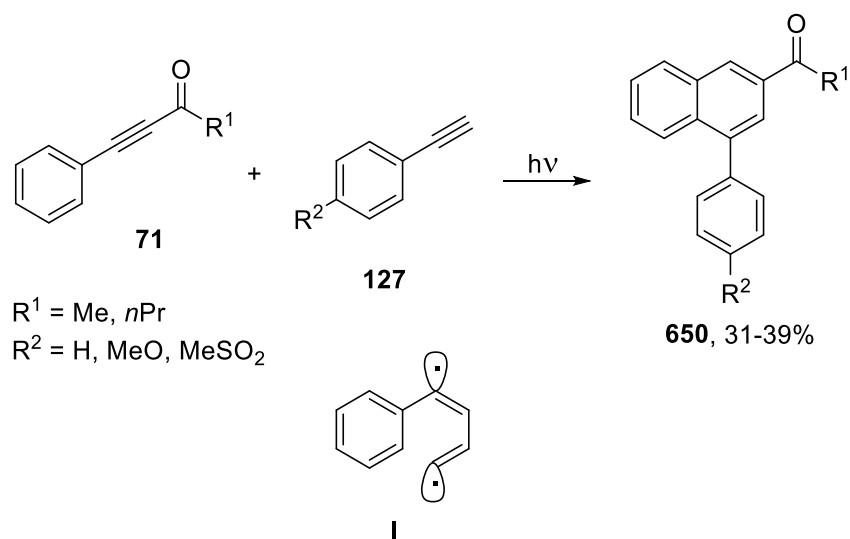

As previously commented (Section 3.2.2.7), Ramachary and co-workers reported that the intermolecular reaction between ynones **71** and isatin derivatives **605** in dichloroethane at room temperature was promoted by tris(4-fluorophenyl)phosphine (**651**), so that spirocompounds **606** were isolated (Scheme 286).⁴⁷⁴ Apart from the dicyano olefin moiety in **605** the presence of two ester groups gave similar results. The proposed mechanism involves intermediates **I-IV**.

Scheme 286. Transformation of Yrones into Spirooxindoles 606

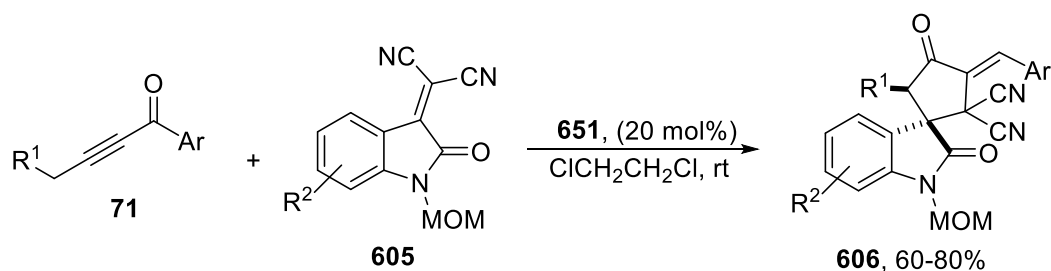

$R^1 = H, Me, Et, MOMO$

$R^2 = H, 5-F, 5-Cl, 5-Br, 5-I, 5,7-Me_2$

$Ar = Ph, 4-MeC_6H_4, 4-MeOC_6H_4, 4-MOMOC_6H_4, 4-FC_6H_4, 4-ClC_6H_4, 2-thienyl$

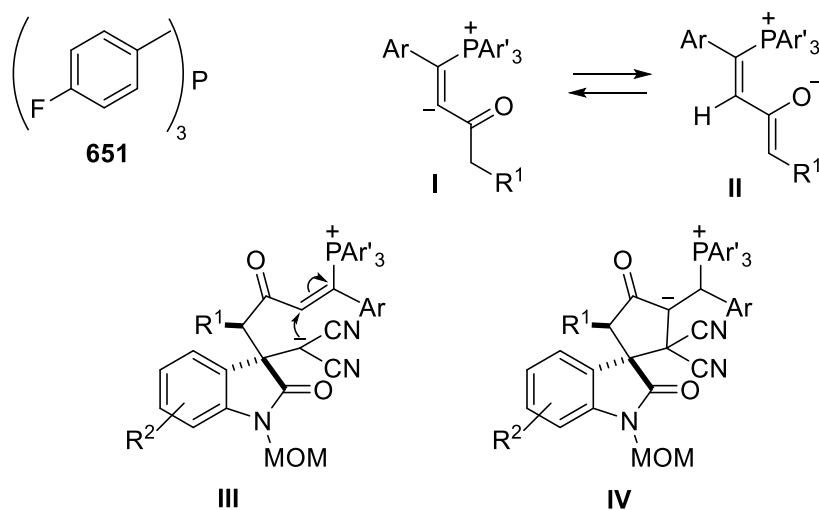

Curiously, when the reaction shown in Scheme 286 was performed by Cui and co-workers with compounds **71** and **605** and with PPh_3 /BINOL as catalyst, isomeric products (**652**) were isolated (Scheme 287). In this case intermediates **I-IV** can explain the different behavior observed compared to what happened in the previous reaction (Scheme 286).⁴⁹⁷

Scheme 287. Conversion of Yrones 71 into Spirooxindoles 652

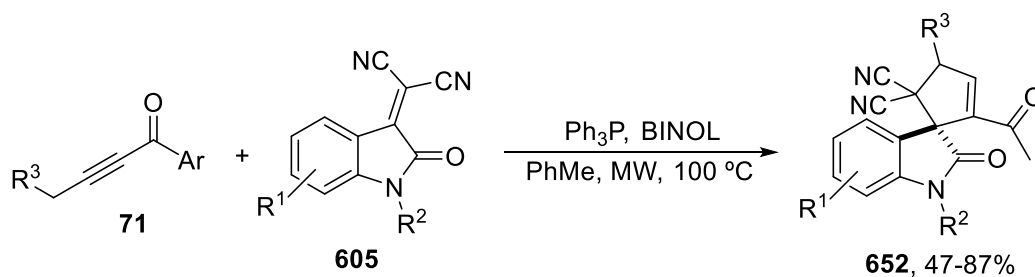

$R^1 = \text{H, 4-Br, 4-Cl, 5-Br, 5-Cl, 5-O}_2\text{N, 5-Me, 6-Me}$

$R^2 = \text{Me, Ph, Bn, MeOCH}_2, \text{HC}\equiv\text{CCH}_2, \text{Boc, Ac}$

$R^3 = n\text{Pr, } n\text{C}_5\text{H}_{11}, \text{Ph}$

$\text{Ar} = \text{Ph, 2-BrC}_6\text{H}_4, \text{3-MeOC}_6\text{H}_4, \text{3,4-Cl}_2\text{C}_6\text{H}_3, \text{4-ClC}_6\text{H}_4, \text{4-MeC}_6\text{H}_4, \text{4-MeOC}_6\text{H}_4, \text{2-furyl}$

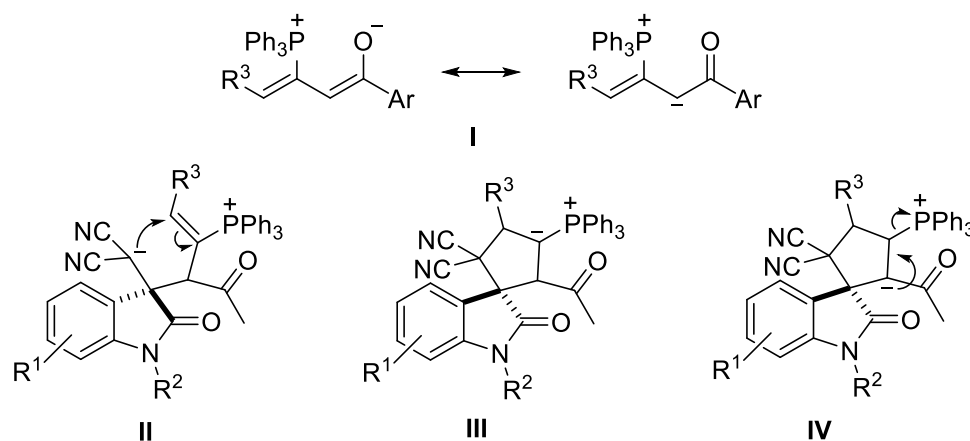

As mentioned in Section 3.2.2.7, another family of spirocompounds (**604**) was prepared by Huang and co-workers by a phosphine-catalyzed [3+2] annulation between ynones **71** and 2-arylidene-1,3-diones **603**.⁴⁷³ The main synthetic interest of this process is the formation of a quaternary center in the products (Scheme 288). Based on the results of labeling experiments, it is envisaged that intermediates **I-V** are involved in the reaction.

Scheme 288. Preparation of Spiro Ketones 604 by Reaction of Ynones 71 with Diones 603

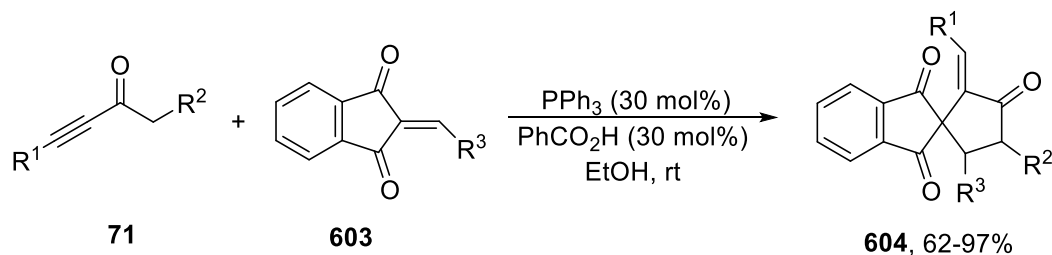

R¹ = *n*Bu, Ph, 4-MeC₆H₄, 4-FC₆H₄

R² = H, Me, Me₂

R³ = Ph, 2-BrC₆H₄, 3-Br-C₆H₄, 4-BrC₆H₄, 2-MeC₆H₄, 3-MeC₆H₄, 4-MeC₆H₄, 4-ClC₆H₄, 4-FC₆H₄, 4-MeOC₆H₄, 4-O₂NC₆H₄, 2,4-Cl₂C₆H₃, 2-furyl, 2-thienyl, 1-naphthyl, PhCH=CH

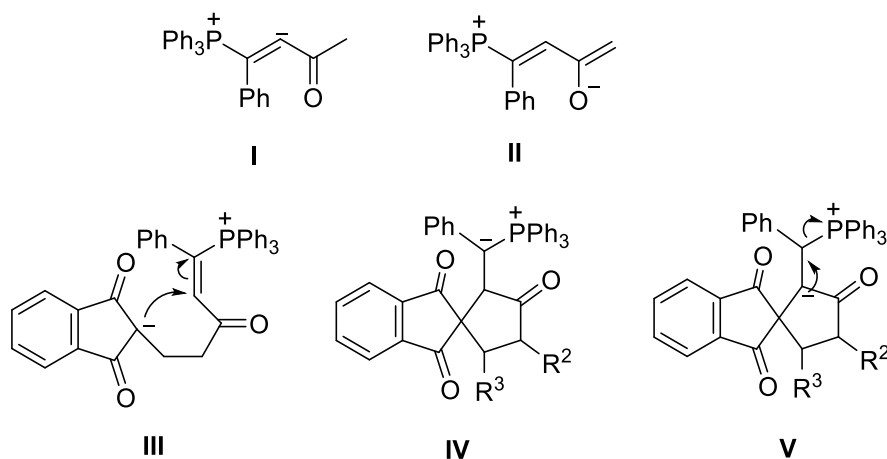

Concerning intramolecular carbocyclizations of ynones, there are several reports about formation of mono and bicyclic products. Zhang and co-workers studied an insertion of an inactivated Csp³-H bond in ynones promoted by gold.⁴⁹⁸ Thus, ynones **71** and **653** gave the corresponding cyclopentanone derivatives **654** and **655**, respectively by treatment with AuCl/AgNTf, ligand **656** and amine oxide **657** in fluorobenzene at room temperature (Scheme 289).⁴⁹⁸ Insertion of a C γ -H into a gold carbene (**I**) has been postulated as possible reaction pathway for ynones **71**.

Scheme 289. Synthesis of Cyclopentanones 654 and 655 from Ynones 71 and 653, Respectively

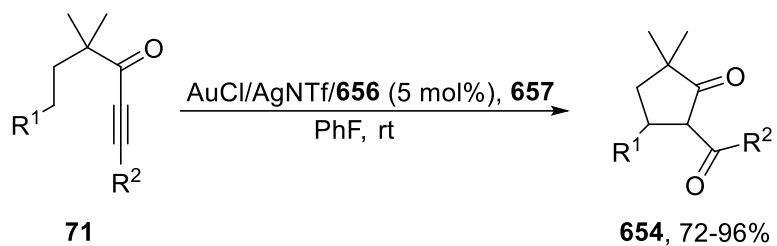

$R^1 = n\text{Bu, } i\text{Bu, TIPSu, Cy}$
 $R^2 = n\text{Bu, Ph}$

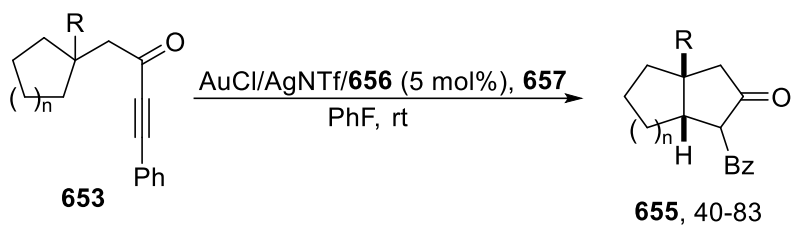

$n = 1, 2$
 $R = \text{H, Me, TIPSu}$

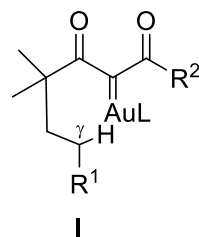
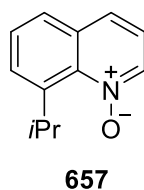
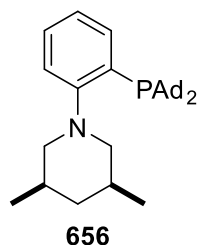

Another intramolecular carbocyclization, promoted by magnesium iodide, was reported by Frontier and co-workers,⁴⁹⁹ who in this way converted ynone **658** to cyclohexenol derivative **659** (Scheme 290). Intermediates **I** and **II** were proposed to explain the formation of **659**. Application of this methodology to a cyclic ynone (**660**) afforded a bicyclic ketone (**661**), which contains a bicyclo[9.3.1]pentadecane core and appears to be a useful intermediate for the synthesis of phomactin A.⁴⁹⁹

Scheme 290. Cyclization of Ynones 658 and 660 Promoted by MgI₂

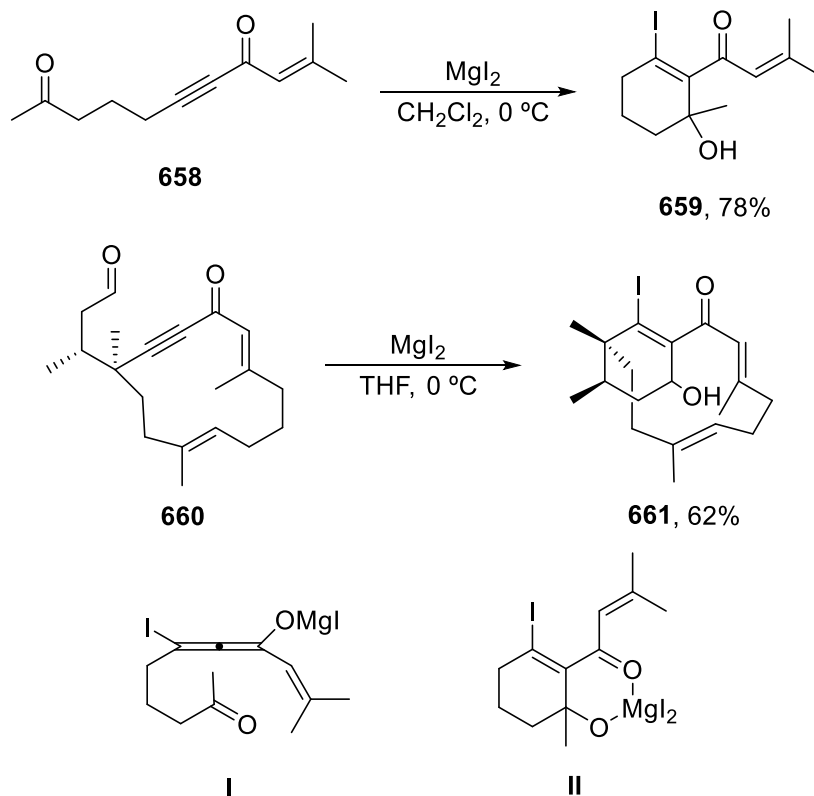

A Rh-catalyzed cyclization of ynones **96** allows the preparation of polysubstituted cyclopentenones (**662**), which are suitable starting materials for the synthesis of hydroazulenoisindoles (Scheme 291).^{500,501}

Scheme 291. Cyclization of Ynones 96 to Cyclopentenones (662)

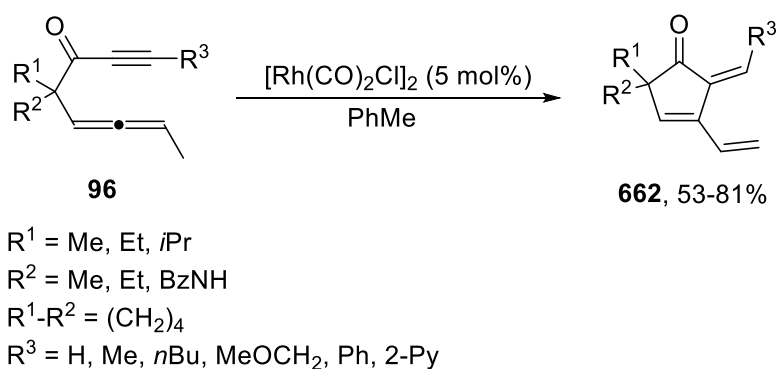

In a rather similar process, enynones (**663**) were cyclized to give bicyclic compounds (**664**) in a palladium-catalyzed reaction involving acylzirconocene **258** in the presence of dimethylzinc (Scheme 292).⁵⁰²

Scheme 292. Cyclization of Ynones 663 to Give Bicycles 664

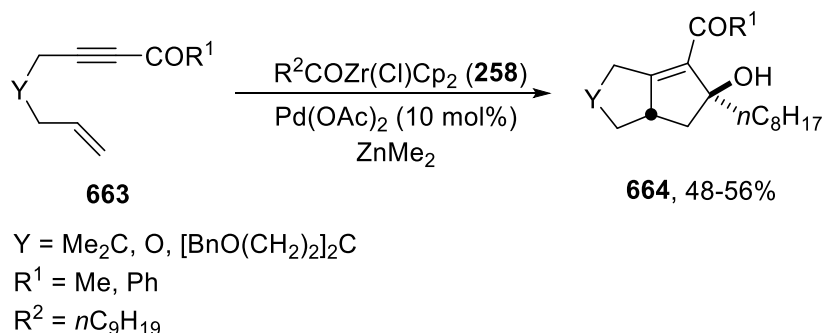

When the alkynyl keto group is attached to an indol, a benzothiophene or a benzofuran, such as in **665**, the phosphine-promoted cyclization led to the formation of tricyclic compounds (**666**) in a diastereoselective manner (Scheme 293).⁵⁰³ In order to explain the formation of **666**, intermediates **I** and **II** have been postulated to take part in the transformation.

Scheme 293. Transformation of Ynones 665 into Tricyclic Compounds 666

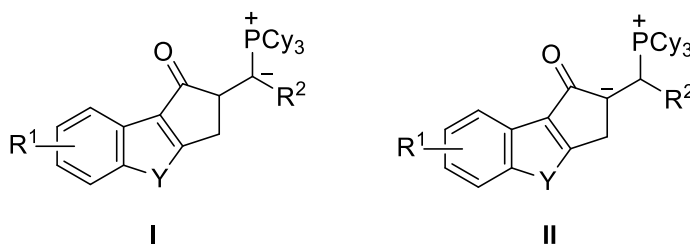
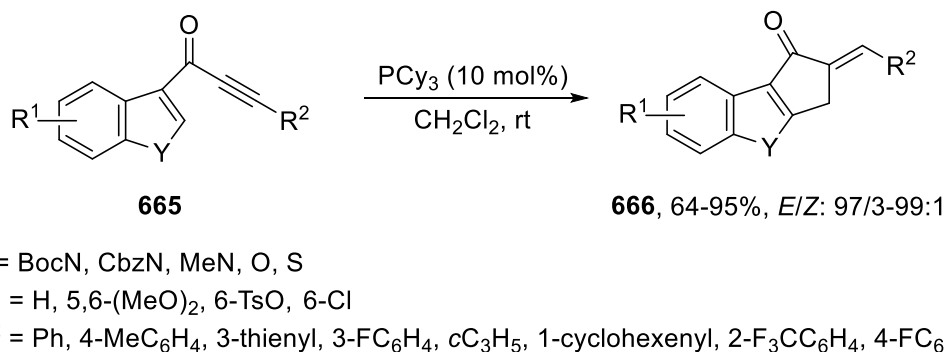

Ramasastri and co-workers prepared another family of tricyclic compounds (**668**) in good yields by exposing benzothiophenes (**667**) with an alkynyl keto functionality anchored at the 2-position to tricyclohexylphosphine (Scheme 294).⁵⁰⁴ A mechanism involving intermediates **I-III** explains the formation of **668**.

Scheme 294. Cyclization of Ynones 667 to Give Tricycles 668

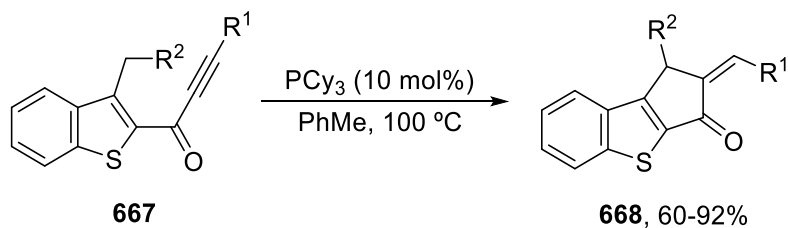

$R^1 = \text{Ph, 4-}i\text{PrC}_6\text{H}_4, 4\text{-MeOC}_6\text{H}_4, 3\text{-FC}_6\text{H}_4, 4\text{-PhC}_6\text{H}_4, 3\text{-MeC}_6\text{H}_4, c\text{C}_3\text{H}_5, 5\text{-MeC}_6\text{H}_4, 2\text{-thienyl}$
 $R^2 = \text{Ph, 3-MeC}_6\text{H}_4, 2\text{-thiobenzothieryl}$

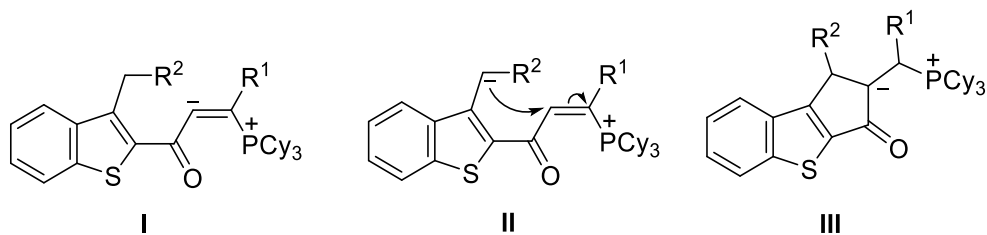

A series of ynones containing an indole moiety (**270**) can be converted to either spirocompounds (**669**) or fused cyclopentenones (**670**), the temperature being responsible for the final outcome (Scheme 295). In order to explain mechanistically this reaction intermediates **I** and **671** have been proposed⁵⁰⁵ (see also Scheme 348³²²).

Scheme 295. Conversion of Ynones 270 into Cyclopentenones 669 or 670

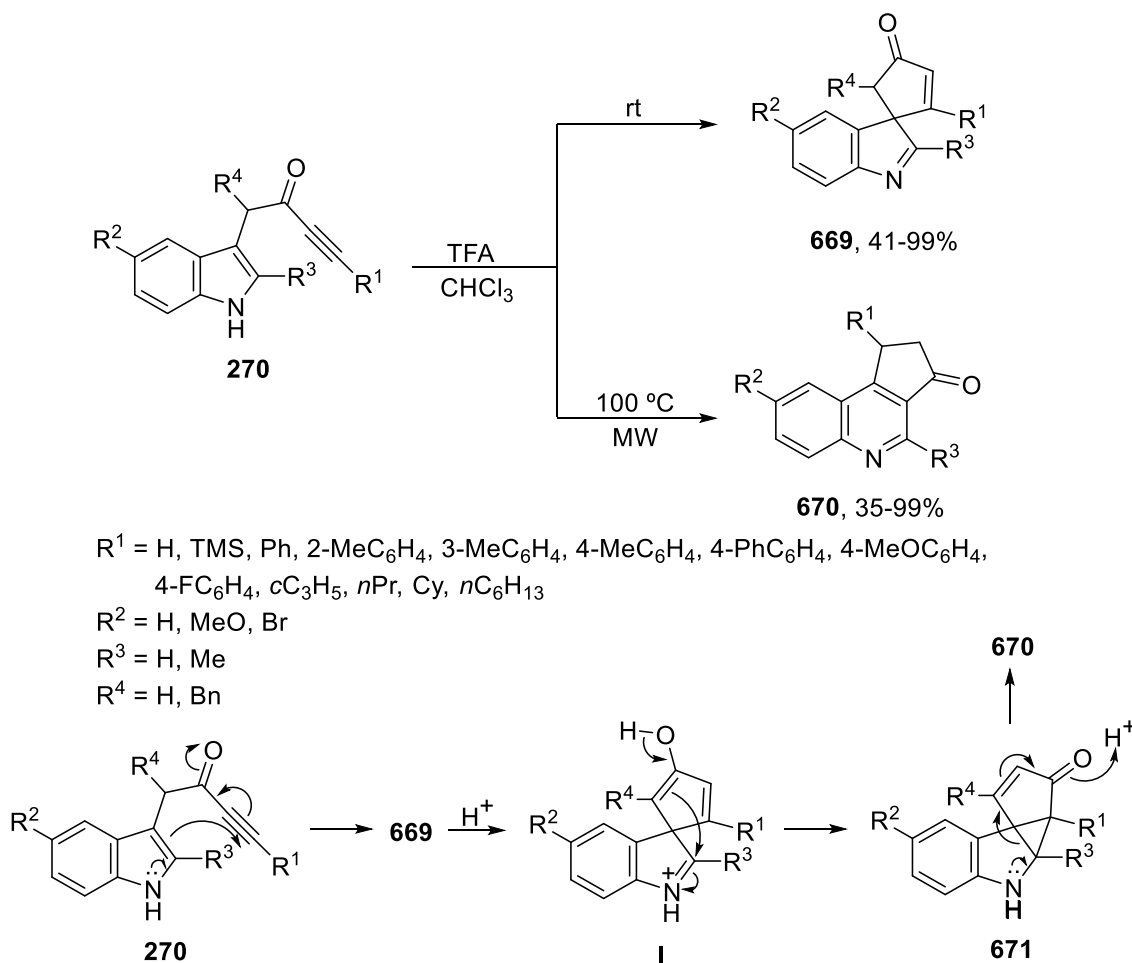

Finally, Ji and co-workers reported the gold-promoted cycloaromatization of ynones **672** in the presence of the quinoline oxide (**673**) to yield a series of phenanthrene derivatives (**674**) (Scheme 296).⁵⁰⁶ A catalytic cycle involving intermediates **I-IV** was postulated to drive the process forward.

Scheme 296. Cyclization of Ynones (672) to Phenanthrenes (674)

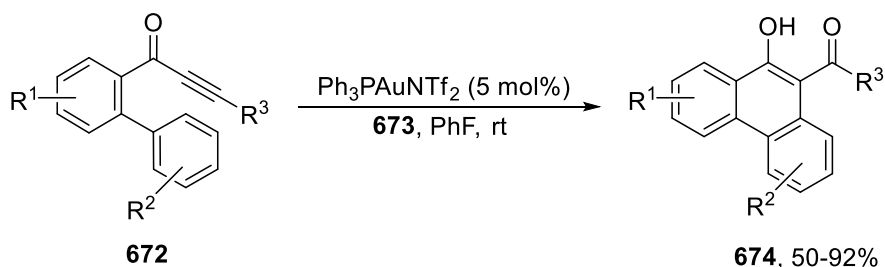

$R^1 = \text{H, 4-Cl, 2-MeO}$

$R^2 = \text{H, 3-Me, 4-MeO, 4-F}$

$R^3 = \text{4-MeC}_6\text{H}_4, \text{4-MeOC}_6\text{H}_4, \text{4-ClC}_6\text{H}_4, \text{2-MeC}_6\text{H}_4, \text{2-BrC}_6\text{H}_4, \text{1-naphthyl, 2-thienyl, } n\text{Bu, } c\text{C}_3\text{H}_5, \text{Ph}$

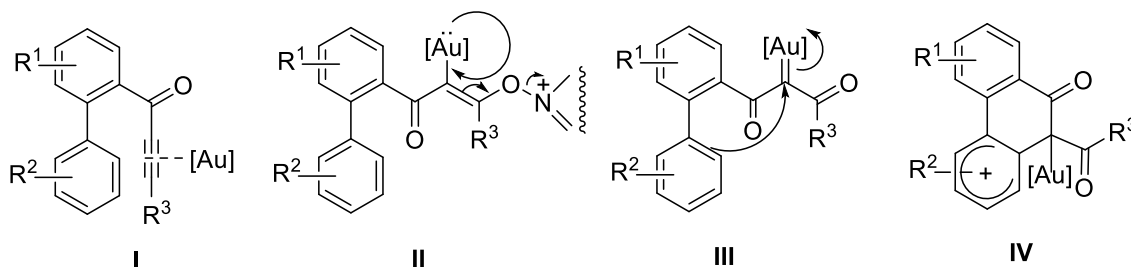
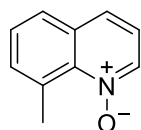

Wender and co-workers described an intramolecular [5+2] cycloaddition of compound **44**, catalyzed by the Rh complex $[\text{Rh}(\text{CO})_2\text{Cl}]_2$ in 1,2-dichloroethane, which furnished a tricyclic ketone (**675**) containing the skeleton of cythiane diterpenes (Scheme 297).⁴³ The proposed mechanism involves first an oxidative addition to give intermediate **I**, which by ring opening of the cyclopropane affords intermediate **II**. Final reductive elimination yields the tricyclic product.

Scheme 297. Preparation of Tricycle **675** by [5+2] Cyclization of **44**

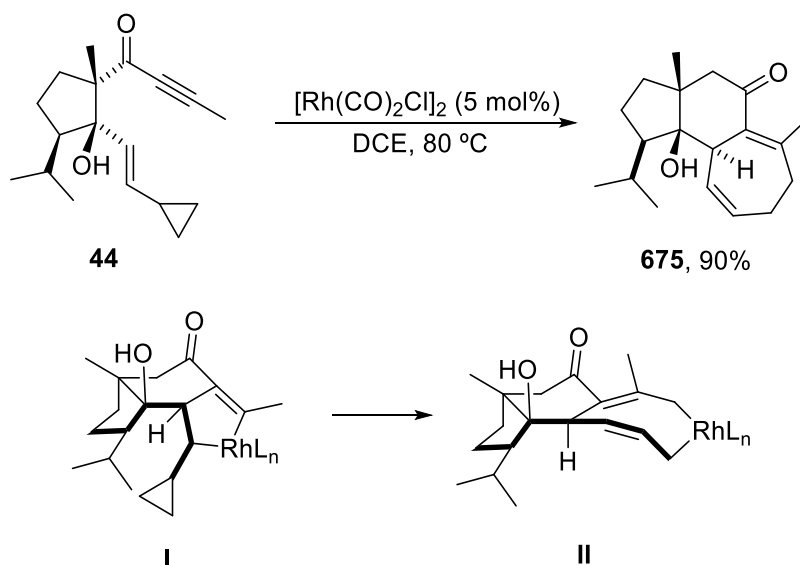

Transformation of diyones **56** into the corresponding 1,6- and 1,8-naphthalenophanes **676** and **677** has been achieved by Wessig and Matthes photochemically, conceivably via diradicals **I** and **II** (Scheme 298).⁵⁸

Scheme 298. Photochemical Transformation of Diyones 56 into Naphthalenophanes 676 and 677

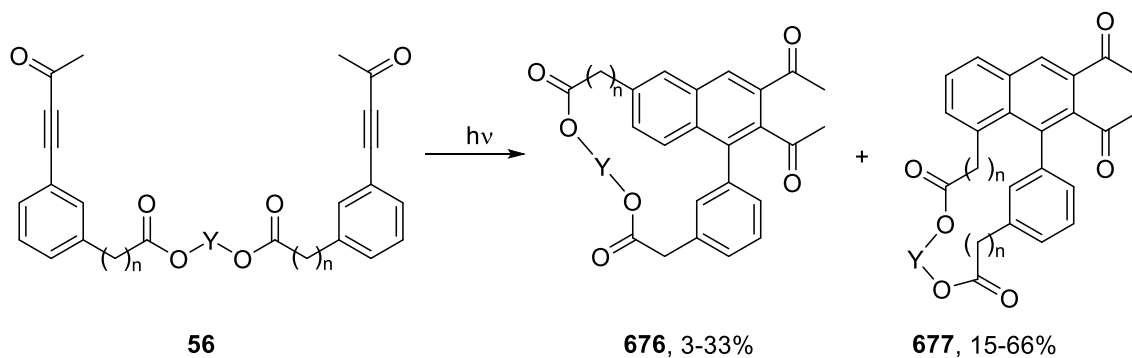

$n = 0, 2$

$Y = (\text{CH}_2)_2, (\text{CH}_2)_4, (\text{CH}_2)_6, (\text{CH}_2\text{CH}_2\text{O})_2(\text{CH}_2)_2$

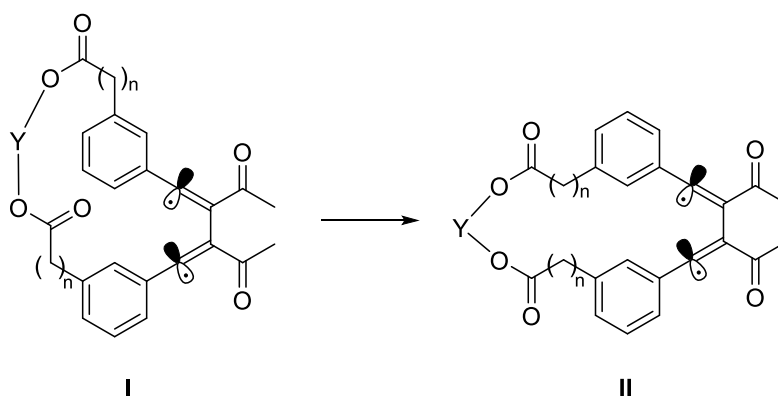

A straightforward radical cascade cyclization was described by Pattenden and co-workers in which a monocyclic ynone (**678** or **679**) was treated with a tin hydride in the presence of AIBN giving tetracyclic products **680/681** and **682**, respectively, with the estrone skeleton (Scheme 299).⁵⁰⁷ Actually, compound **681** was transformed into (\pm)-14-*epi*-estrone in a five-step synthesis with a 3% overall yield. Remarkably, the stereochemistry of the final products is defined by the geometry of one of the double bonds of the starting ynone.

Scheme 299. Radical Cascade Annulation of Ynones 678 and 679 to Tetracyclic Products 680-682 with Estrone Skeleton

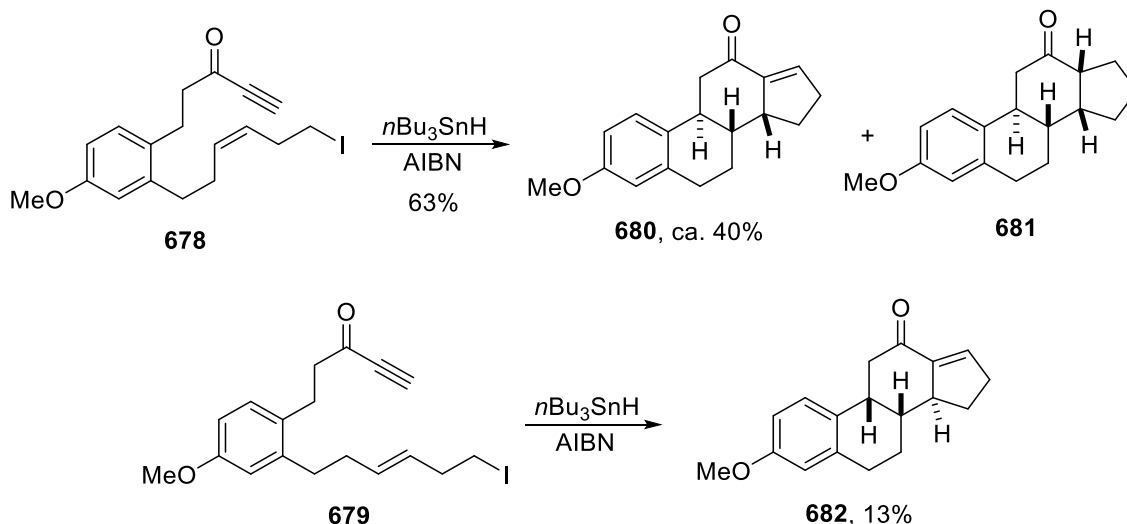

An asymmetric [3+2] cycloaddition took place when a mixture of 3-amino oxindoles (**683**), aldehydes, and aromatic ynones (**71**) was subjected to a chiral phosphoric acid (**577**; Ar = 9-phenanthryl) and furnished spirocompounds **684** (Scheme 300).⁵⁰⁸ Dehydrogenation of these compounds with DDQ afforded the expected pyrroles, which are of importance in medicinal chemistry.

Scheme 300. Reaction of Aminoxindoles (683), Aldehydes, and Ynones (71) to Yield Spirocompounds 684 by CPA (577) Catalysis

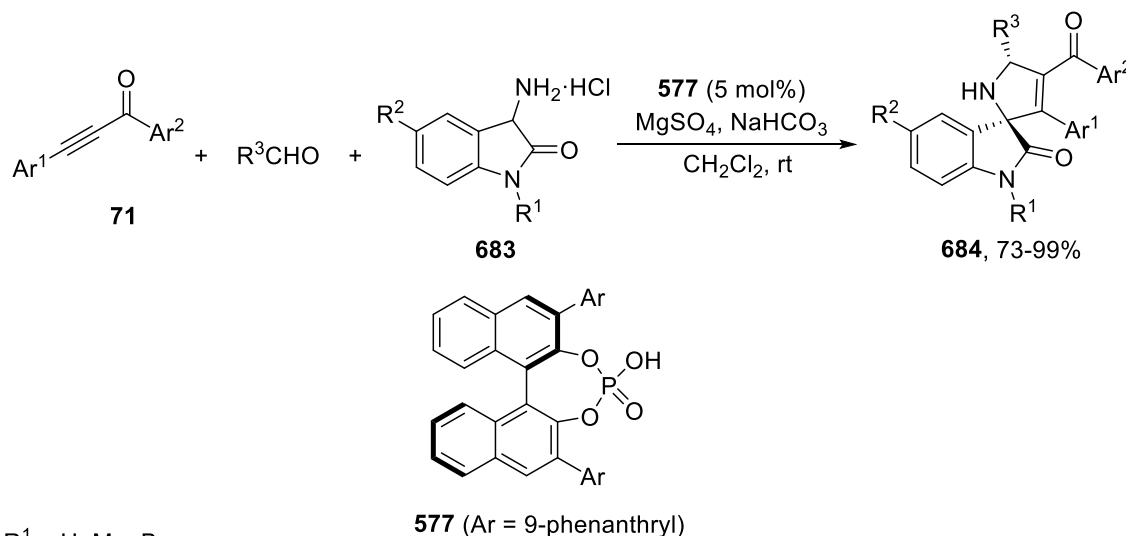

$\text{R}^1 = \text{H, Me, Bn}$

$\text{R}^2 = \text{H, Me, F}$

$\text{R}^3 = \text{Ph, 4-FC}_6\text{H}_4, 3,4\text{-Cl}_2\text{C}_6\text{H}_3, 4\text{-BrC}_6\text{H}_4, 4\text{-O}_2\text{NC}_6\text{H}_4, 3\text{-MeC}_6\text{H}_4, 4\text{-MeOC}_6\text{H}_4, 2\text{-naphthyl, 2-thienyl}$

$\text{Ar}^1 = \text{Ph, 4-FC}_6\text{H}_4, 4\text{-ClC}_6\text{H}_4, 4\text{-MeC}_6\text{H}_4, 3\text{-MeC}_6\text{H}_4, 4\text{-MeOC}_6\text{H}_4, 2\text{-thienyl}$

$\text{Ar}^2 = \text{Ph, 4-FC}_6\text{H}_4, 3\text{-ClC}_6\text{H}_4, 4\text{-BrC}_6\text{H}_4, 4\text{-O}_2\text{NC}_6\text{H}_4, 3\text{-MeC}_6\text{H}_4, 2\text{-naphthyl}$

3.2.4.2. Heterocyclizations. In this section cyclization of ynones to give nitrogen- and oxygen-containing heterocycles will be considered.

3.2.4.2.1. Nitrogen-Containing Heterocycles. A series of substituted indolizidines (**686** or **687** as ZnCl_2 complexes) were prepared by treatment of ynones (**685**) with

MeSO₃H or ZnCl₂, respectively (Scheme 301).⁵⁰⁹ In the first case a Meyer-Schuster rearrangement took place, in the second the ZnCl₂ complexes were further reduced (NaBH₄) to 3-alkynylindolizidines.

Scheme 301. Preparation of Compounds 686 and 687 from Ynone 685

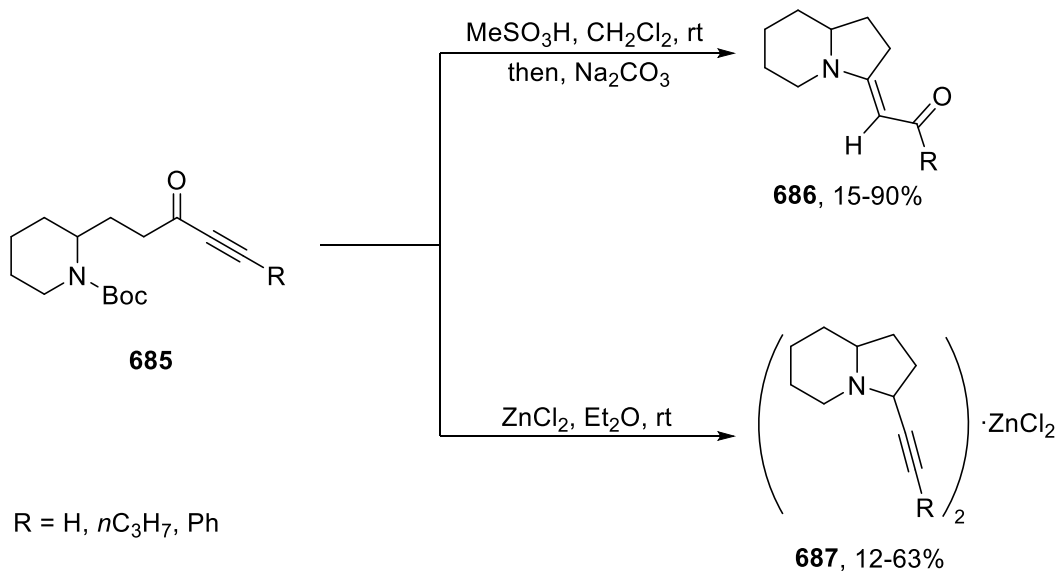

Depending on the size of the nitrogen-containing ring in cyclic sulfonamides (**688**), their treatment with a gold(I) complex gave bicyclic enones (**689**) (*n* = 1), or pyrroles (**690**) (*n* = 2) or **691** (*n* = 3) by a *N*-desulfonylative amination (Scheme 302). This substrate-dependent divergent synthesis has been applied to the formal synthesis of the possible antileukemic agent (+)-*nor*-NP25302.⁵¹⁰ Vinylgold intermediate **I** has been proposed as a transient species in the reaction.

Scheme 302. Transformation of Cyclic Sulfonamides 688 into Compounds 689-691

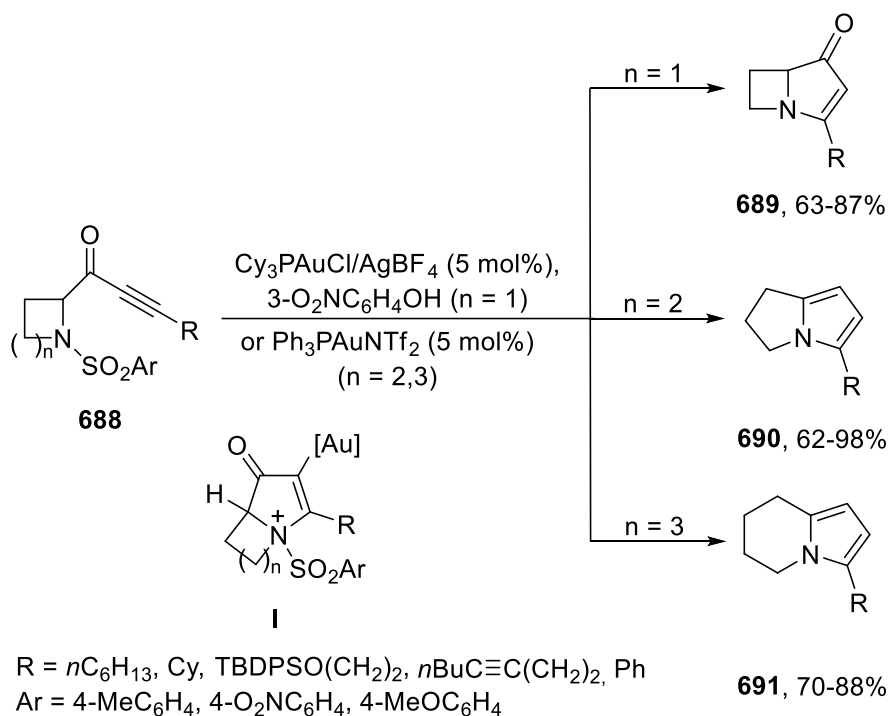

It is also possible to prepare heterocycles containing two nitrogen atoms starting from ynones (Section 3.1.3.1.3.1). Treatment of trifluoro ynones **363** with phenylhydrazine, depending on the reaction conditions, gave pyrazoles **365** or their regioisomers **364** (Scheme 303).³⁷⁶ This regiodivergent synthesis has been successfully applied to the preparation of Celebrex, a non-steroidal anti-inflammatory drug (Section 3.1.3.1.3).

Scheme 303. Preparation of Regioisomers **364** and **365** from Ynones **363**

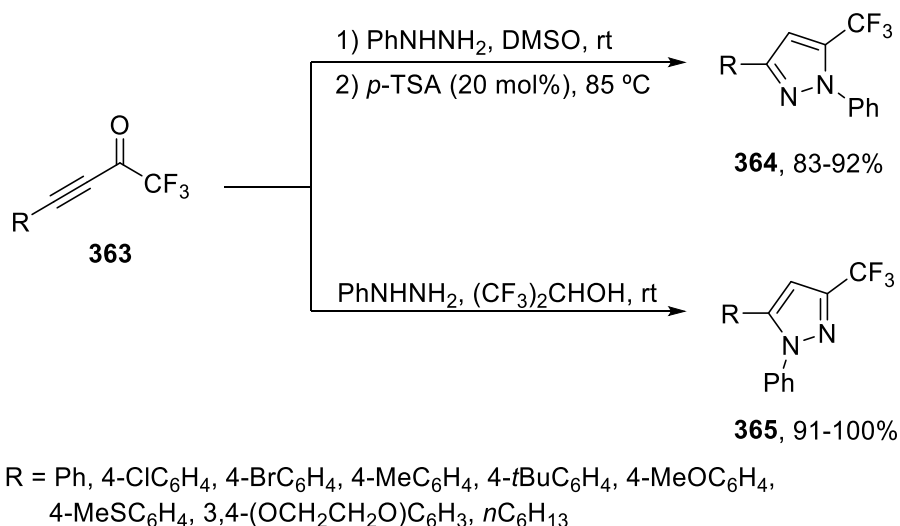

When the ynone has a BF_3K substituent attached to the triple bond (**19**), the boron group is transferred to the pyrazole formed in a regioselective manner by treatment with hydrazines. Thus, **19** (easily available from the corresponding terminal alkynes) were transformed into pyrazoles **362** by reaction with methyl or phenylhydrazine (Scheme 304).²⁸ The reaction also worked properly with unsubstituted hydrazine yielding the

expected products **362** with R= H. The boron group allows easy functionalization at its location in the molecule, mainly by cross-coupling reactions (Section 3.1.3.1.3).

Scheme 304. Preparation of Pyrazoles 362 from Ynones 19

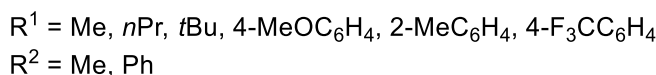
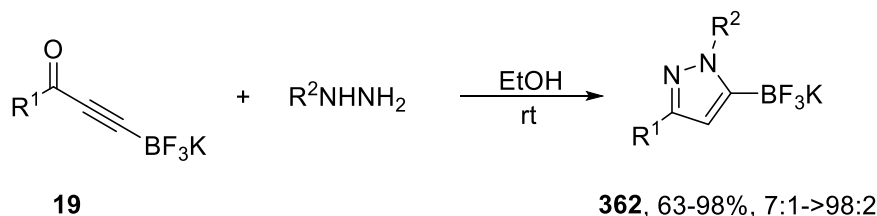

A silver-catalyzed oxidative coupling of anilines with ynones **71** has been shown by Zhang and Xu to be an efficient route for the synthesis of quinolines (**263**) (Scheme 305).⁵¹¹ The mechanistic proposal put forward starts with formation of imine **I** followed by cyclization through the silver-activated alkyne **II**.

Scheme 305. Preparation of Quinolines (263) from Anilines and Ynones (71)

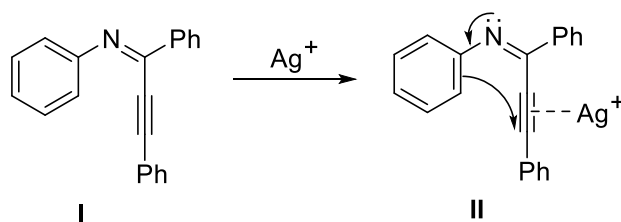
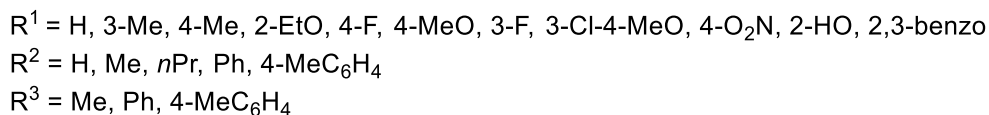
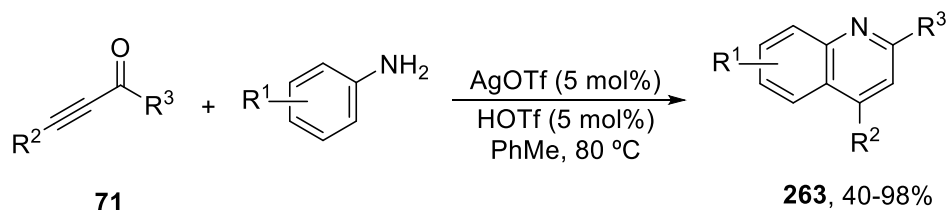

3.2.4.2.2. *Oxygen-Containing Heterocycles*. The groups of Xie⁵¹² and Bolshan¹²⁵ described the cyclization of *o*-hydroxyphenyl ynones (**423**) to yield aurones **692** under different reaction conditions, using either a phosphine⁵¹² or Cs₂CO₃¹²⁵ as reagent (Scheme 306). However, under acidic conditions the corresponding flavones **424** (Section 3.1.3.2.1) were isolated.¹²⁵ For the phosphine-promoted reaction, intermediate **I** has been proposed to take part in the formation of **692** through a kinetically favorable 5-*exo-dig* cyclization.⁵¹²

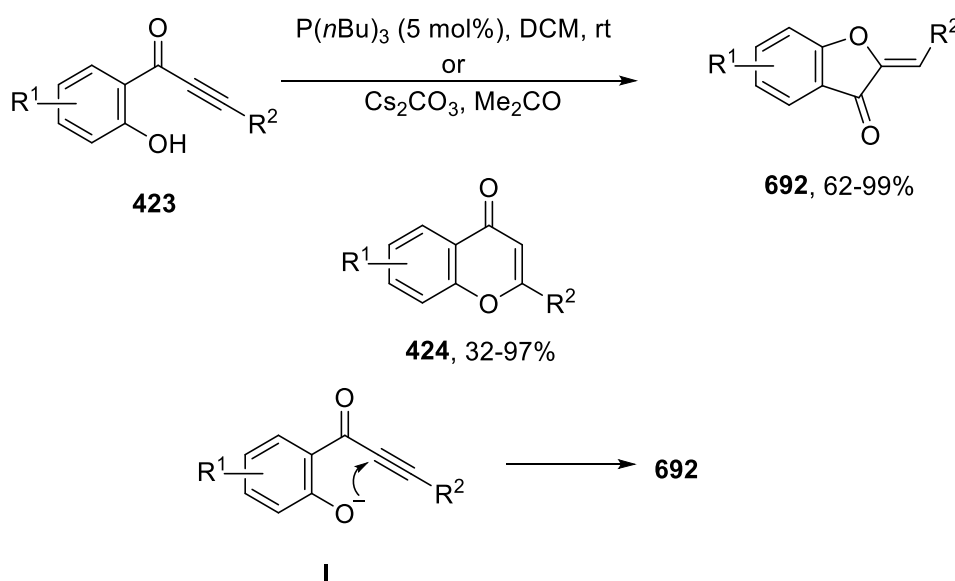
Scheme 306. Conversion of Yrones 423 into Furanones 692 and Flavones 424

Anthracene-derived yrones (**52**) have been converted into the corresponding pyranones **693** by simple treatment with sulfuric acid.⁵⁴ A couple of examples from Stewart and co-workers is depicted in Scheme 307 (see also Section 3.1.3.2.1). Under different reaction conditions (just heating in toluene) the products are the corresponding furan derivatives **694**. The biological activity of both series of compounds has been investigated by the same group.

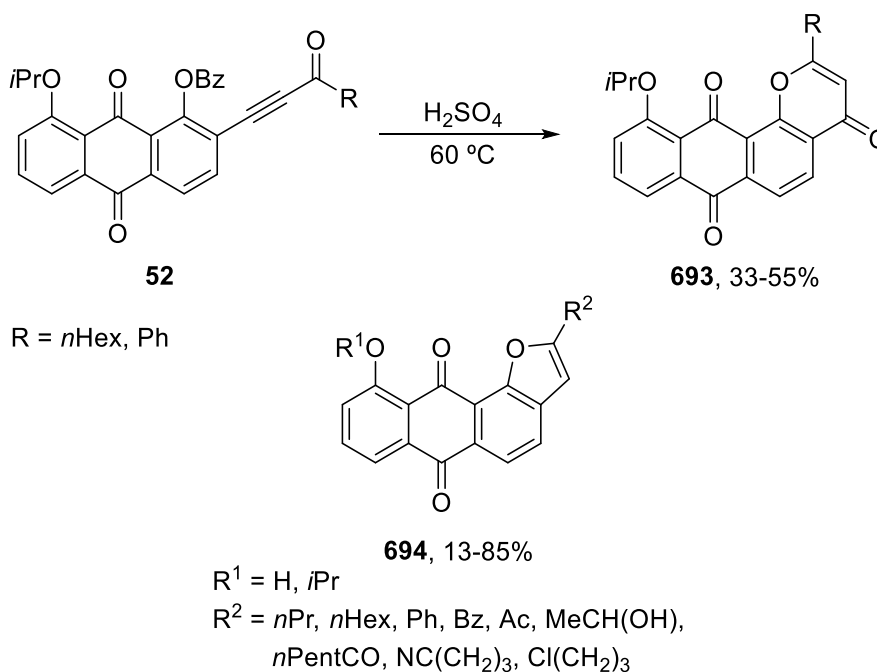
Scheme 307. Conversion of Yrones 52 into Pyranones 693 or Furans 694

Yrones **71** react with different aldehydes in the presence of Cr(II) chloride and TMSCl and afford furans **525** in a direct way (Scheme 308).⁵¹³ A series of intermediates (**I-V**),

resulting from initial electron transfer, have been put forward as possible intermediates to explain the results obtained.

Scheme 308. Reaction of Ynones 71 with Aldehydes to Give Furans 525

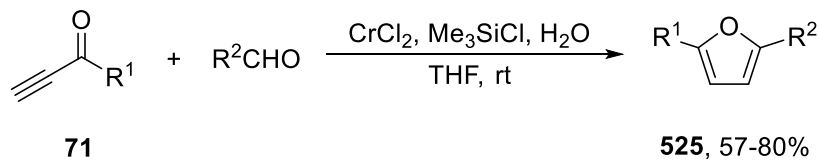

$\text{R}^1 = n\text{C}_8\text{H}_{17}, \text{Cy}, \text{Ph}, \text{MeCO}(\text{CH}_2)_8, \text{Ph}(\text{CH}_2)_2$

$\text{R}^2 = \text{Cy}, \text{Ph}(\text{CH}_2)_2$

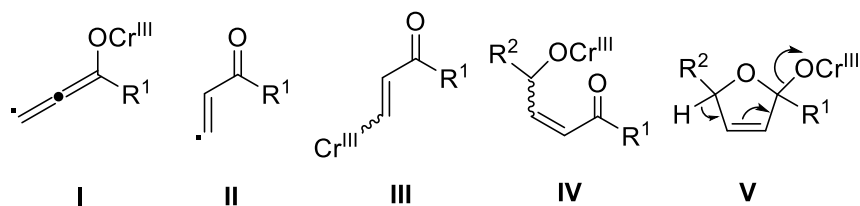

Another way to prepare substituted furans is to react ynones (**71**) with oxabicycles (**695**) under palladium catalysis by palladacycle **696** which leads to formation of tricyclic furans (**697**) in moderate to good yields (Scheme 309).⁵¹⁴ The reaction has been extended to non-oxygenated bicyclic substrates, such as norbornene and norbornadiene with similar results. From a mechanistic point of view, three intermediates (**I-III**) have been proposed to explain the course of reaction.

Scheme 309. Preparation of Furans 697 from Bicycles 695 and Ynones 71

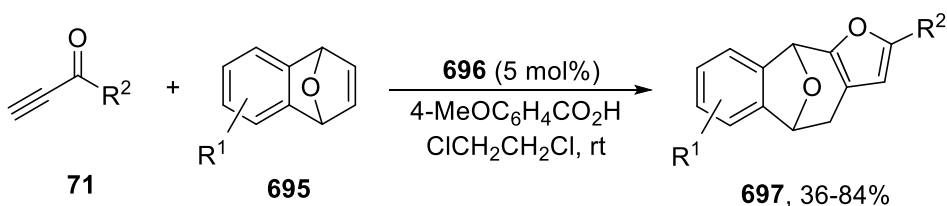

$\text{R}^1 = \text{H}, 2,5\text{-Me}_2, 3,4\text{-(MeO)}_2, 2,5\text{-(MeO)}_2$

$\text{R}^2 = \text{Ph}, 4\text{-MeOC}_6\text{H}_4, 3\text{-MeC}_6\text{H}_4, 4\text{-MeC}_6\text{H}_4, 3\text{-ClC}_6\text{H}_4, 2\text{-MeC}_6\text{H}_4, 1\text{-naphthyl}, 2\text{-furyl}, \text{Me}$

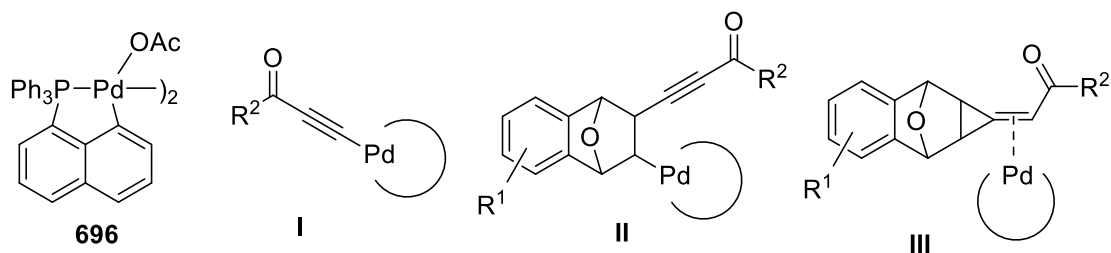

Shi and Lian reported a catalyst-dependent regiodivergent reaction of ynone **71** with isatins (**600**).⁴⁶⁹ When 1,4-dioxabicyclo[2.2.2]octane (DABCO) was used, endocyclic spirooxindoles (**698**) were isolated, but with methyl diphenylphosphine as catalyst, *exo* derivatives **601** (Section 3.2.2.7) were the reaction products (Scheme 310). Mechanistic proposals for both reactions have been put forward; the first process is envisaged to involve intermediates **I** and **II**, the second transients **III-VI**.

Scheme 310. Transformation of Isatins (600**) into Spirooxindoles (**698** and **601**)**

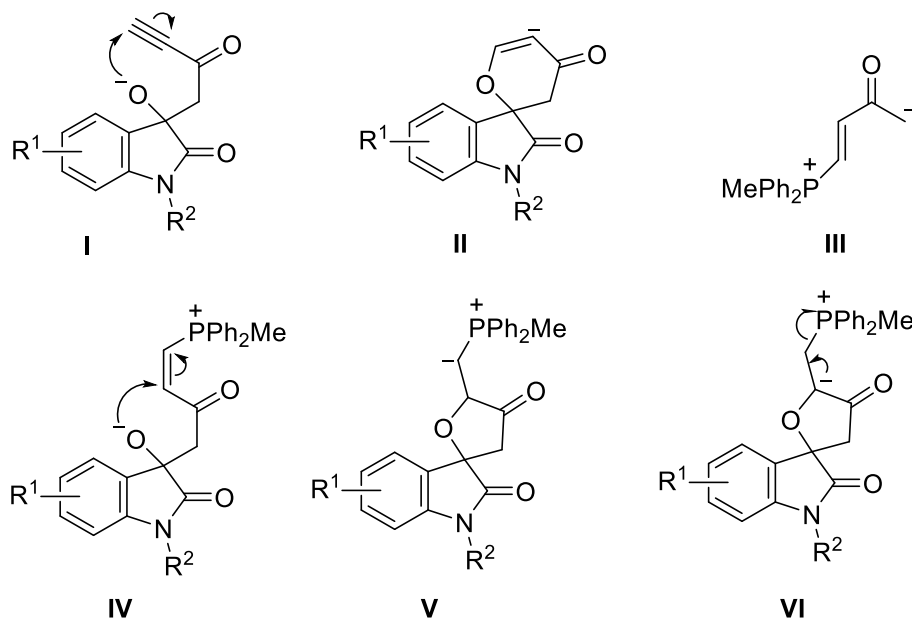
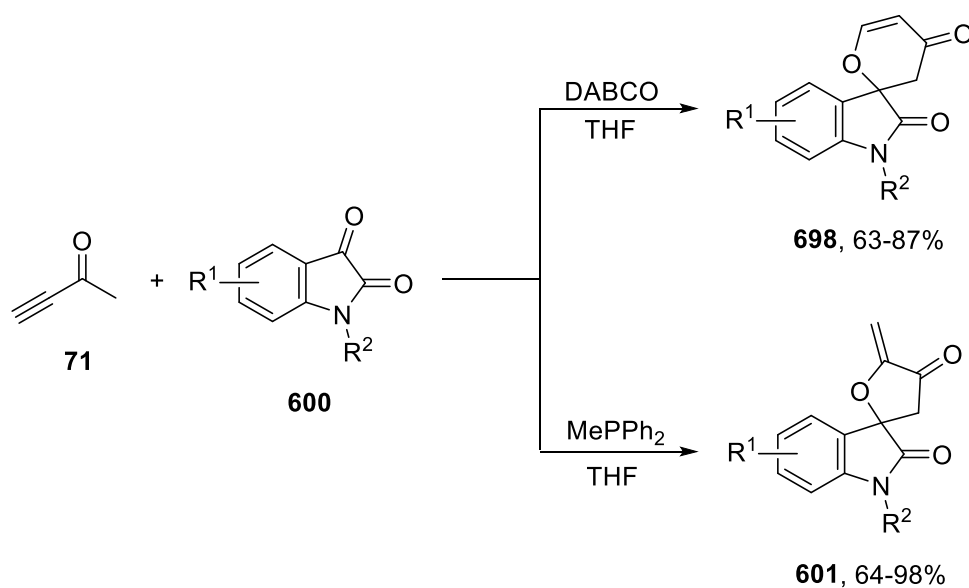

A related contribution from Huang's group reported the same process shown in Scheme 310 but with somewhat different ynones and catalyst ($\text{ArC}\equiv\text{CCOMe}$; $\text{EtPPh}_2/\text{PhCO}_2\text{H}$ in chloroform). The products were derivatives of **601**. It is noteworthy

that an asymmetric version with a BINOL-derived phosphine as catalyst gave poor enantioselectivity.⁴⁷²

Finally, oxaruthena- and oxaosmacyclopentadiene complexes of structures **699** and **700** were easily prepared by mixing the corresponding metal dichlorides with PhCOC≡CH in methanol (Figure 12).⁵¹⁵

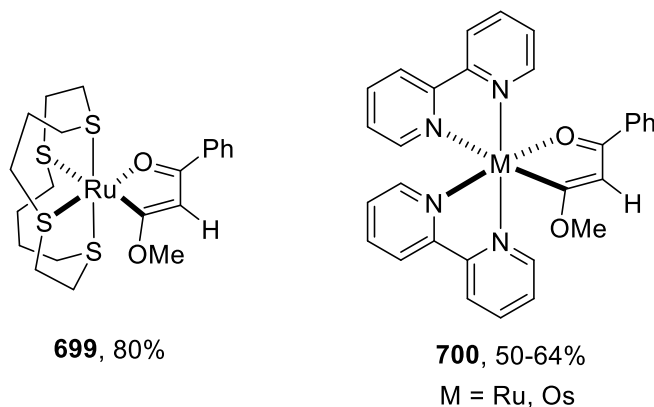

Figure 12. Metalafurans **699** and **700**.

In conclusion, carbo- and hetero-cyclizations, mainly in an intramolecular fashion, have been reported using different promoting agents, such as iodine, light, acids, bases, phosphines and several organometallic reagents. For heterocyclizations, nitrogen- and oxygen-containing products have been easily achieved.

3.3. Reduction of the Triple Bond

Although hydrogenation of alkynes to alkanes can be easily achieved by catalytic (Pd, Pt, Ni) hydrogenation,⁵¹⁶ semi-hydrogenation to give *Z*-alkenes is normally performed using the Lindlar's catalyst,^{517,518} and to *E*-alkenes by using dissolving metals.⁵¹⁹ These methodologies have problems when they are applied to alkynes with additional functionalities that are also susceptible to being hydrogenated. This is the case with ynones, for which the selective reduction of the triple bond in the presence of the carbonyl group is difficult.

Yeh and co-workers reported the use of triphenylphosphine and water for the semi-hydrogenation of ynones (**701**) with an ether functionality in propargylic position giving the corresponding (*E*)-alkenones (**702**) in moderate to good yields (Scheme 311).⁵²⁰ The proposed mechanism involves a conjugate addition of the phosphine to the triple bond producing a zwitterionic intermediate (**I**), which reacts with water to give exclusively the corresponding *trans*-product **702**, through a second intermediate (**II**).

Scheme 311. Formal Semi-Hydrogenation of Ynones 701 to Give (*E*)-Enones 702

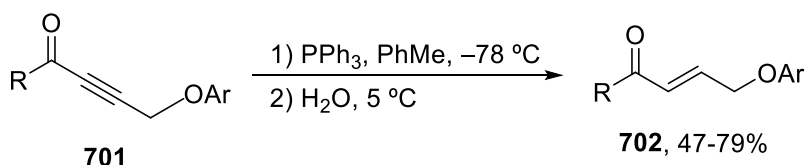

Ar = 4-MeOC₆H₄

R = Me, Ph, (*E*)-MeCH=CH, (*E,E*)-MeCH=CH-CH=CH

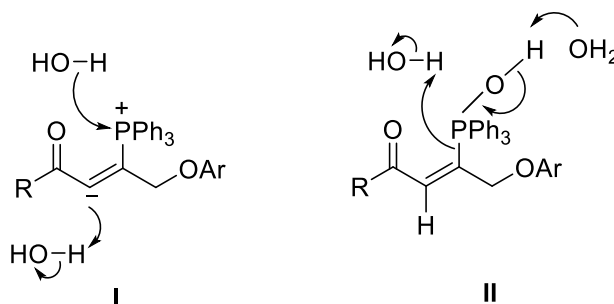

Ynones react with Ru₃(CO)₁₂ in toluene at 90 °C to give a series of ruthenium-carbonyl clusters (Section 3.2.1), whose structures depend on the stoichiometry of the reaction, but in all cases the corresponding enone is attached to one of the Ru atoms.⁴³⁶ No further reactivity of these complexes has been investigated. In a reaction of an ynone with a Rh(I) complex, the same type of compound bearing an enone moiety as ligand of the metal has been isolated.⁵²¹

Sydnés and co-workers reported on the semi-hydrogenation of a functionalized ynone (**703**) by means of the Lindlar's catalyst, which gave the corresponding *cis*-product (**704**) in excellent yield and diastereoselectivity (Scheme 312).⁵²²

Scheme 312. Semi-Hydrogenation of Functionalized Ynone **703** to Enone **704**

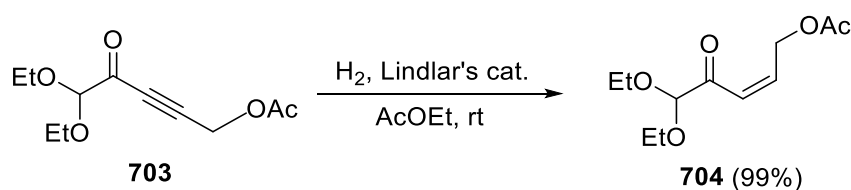

As a conclusion, few reports have been published on the semi-hydrogenation of functionalized ynones: with PPh₃/H₂O (*E*)-enones were obtained whereas the Lindlar's catalyst gave the expected (*Z*)-diastereomers.

3.4. Addition to the Carbonyl Group

The selective addition of carbon and heteroatom nucleophiles to the carbonyl group of ynones and related compounds, as well as the reduction of this functionality, will be considered in this section.

3.4.1. Carbon Nucleophiles. In this case a new carbon-carbon bond is formed and at the same time an alcohol functionality is generated, so a propargyl alcohol is initially formed.

Vicario and co-workers reported the reaction of ynones **71** with aldehydes in the presence of a substoichiometric amount of chiral carbene precursor **705** under basic conditions, which gave the corresponding chiral products **706** in high yields with high enantioselectivities (Scheme 313).⁵²³ *E*-Breslow intermediate **I** reacts preferentially through the topicity showed in **II**, compared to **III**, to give the major enantiomer.

Scheme 313. Enantioselective Cross-Benzoin Reaction of Ynones **71 with Aldehydes to Give Alcohols **706****

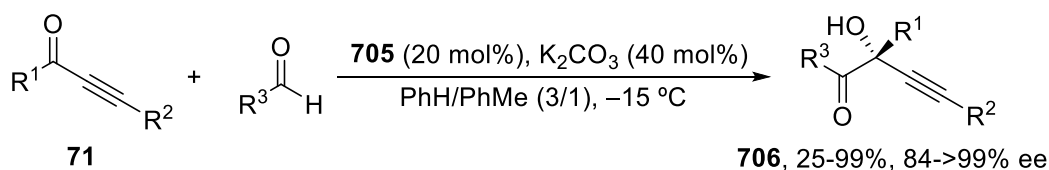

$\text{R}^1 = \text{Me, CF}_3, \text{Et}$

$\text{R}^2 = n\text{Pr, Cy, Ph, 4-MeC}_6\text{H}_4, 4\text{-MeOC}_6\text{H}_4, 4\text{-BrC}_6\text{H}_4, 2\text{-thienyl, Si/Pr}_3$

$\text{R}^3 = \text{Et, } c\text{C}_3\text{H}_5, n\text{Pr, Ph, 4-BrC}_6\text{H}_4, 4\text{-FC}_6\text{H}_4, 4\text{-F}_3\text{CC}_6\text{H}_4, 2\text{-thienyl, 2-furyl}$

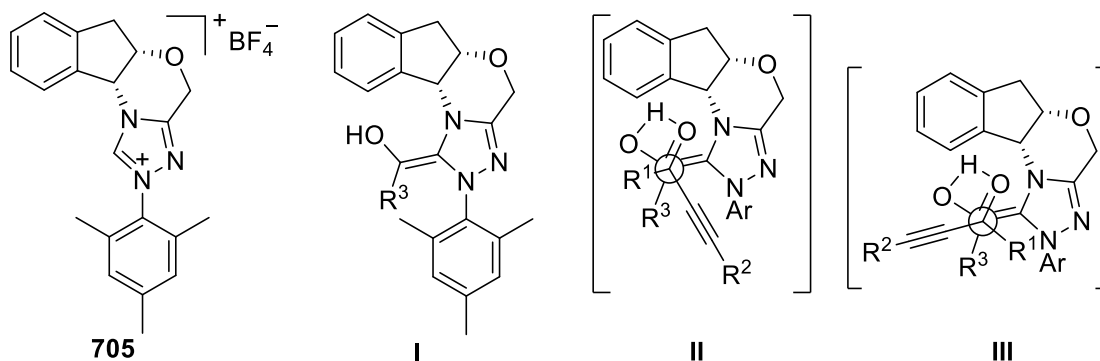

Hoveyda's group has studied the enantioselective addition of dimethylzinc and diethylzinc to a series of pyridine-derived ynones (**707**) promoted by aluminum triisopropoxide and a chiral ligand (**708** or **709**) (Scheme 314). For diethylzinc ligand **708** was the most efficient, whereas **709** gave the best results when dimethylzinc was used. The resulting chiral alcohols (**710**) were easily transformed into chiral indolizidines by treatment with a catalytic amount of copper(I) iodide.⁵²⁴ A computational study supports a rationale for these results.

Scheme 314. Enantioselective Addition of Dialkylzinc Reagents to Ynones **709**

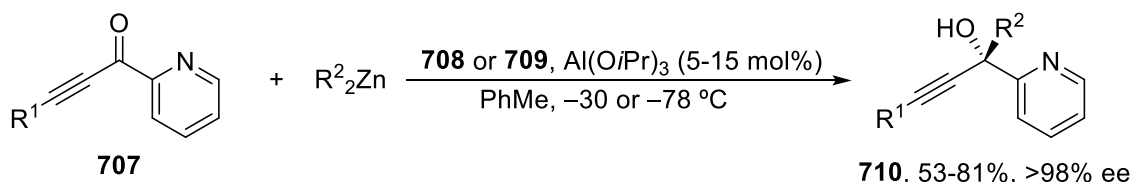

R^1 = Ph, 2-MeC₆H₄, 3-MeC₆H₄, 4-MeC₆H₄, 4-MeOC₆H₄, 4-F₃CC₆H₄, 4-IC₆H₄, 3,4-Cl₂C₆H₃,
2-BrC₆H₄, 3-thienyl, *n*C₆H₁₃, Cy, *i*Pr₃Si
 R^2 = Me, Et,

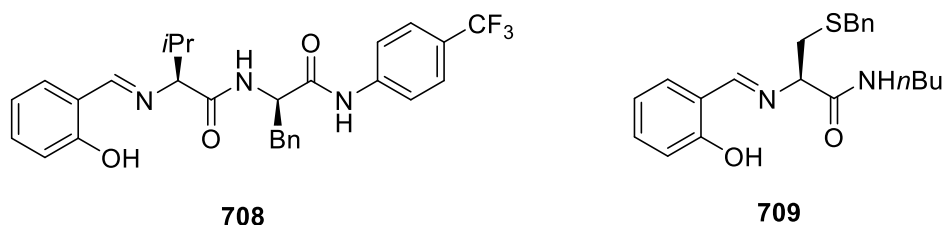

The enantioselective condensation of aldehydes with α -alkynyl aldehydes was extended to ynones **187** bearing an extra ester functionality attached to the carbonyl group. By using chiral ligand **711** and benzoic acid in substoichiometric amounts the corresponding products (**712**) were isolated after acetalization (Scheme 315). When the aldehyde has a C=C bond in the chain [$R = \text{CH}_2=\text{CH}(\text{CH}_2)_2$] a Pauson-Khand reaction gave the expected cyclopentenone derivatives in an enantiomerically almost pure products.⁵²⁵

Scheme 315. Condensation of Aldehydes with Keto Esters **187**

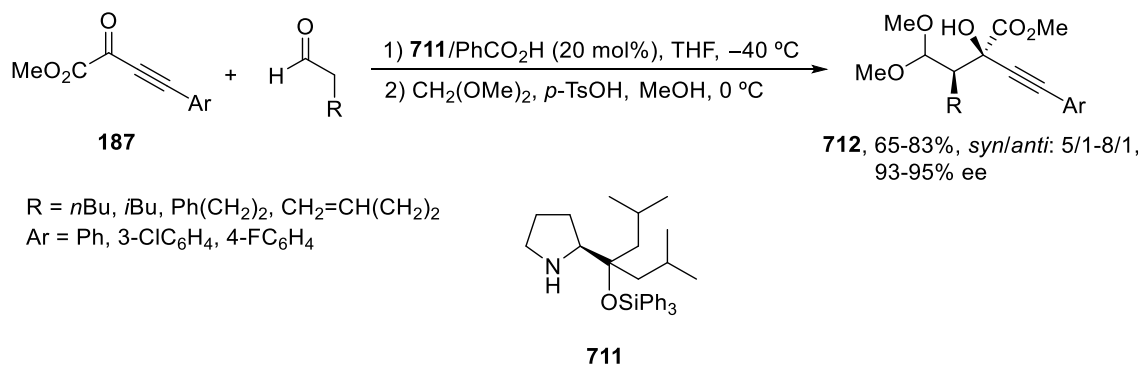

The Pauson-Khan cyclization was the key step in the formation of a tetracyclic system from the reaction of ynone **713** with cyclobutene acyloin **714**. The process starts with conversion of the ynone into cyclopentadione **715** by reaction with **714** promoted by boron trifluoride (Scheme 316).⁵²⁶ Diketone **715** was then reduced to **716**, which was subjected to the Pauson-Khan protocol and after two more steps afforded the desired tetracyclic compound **717**.¹⁰⁰

Scheme 316. Transformation of Ynone **713** into Product **717**

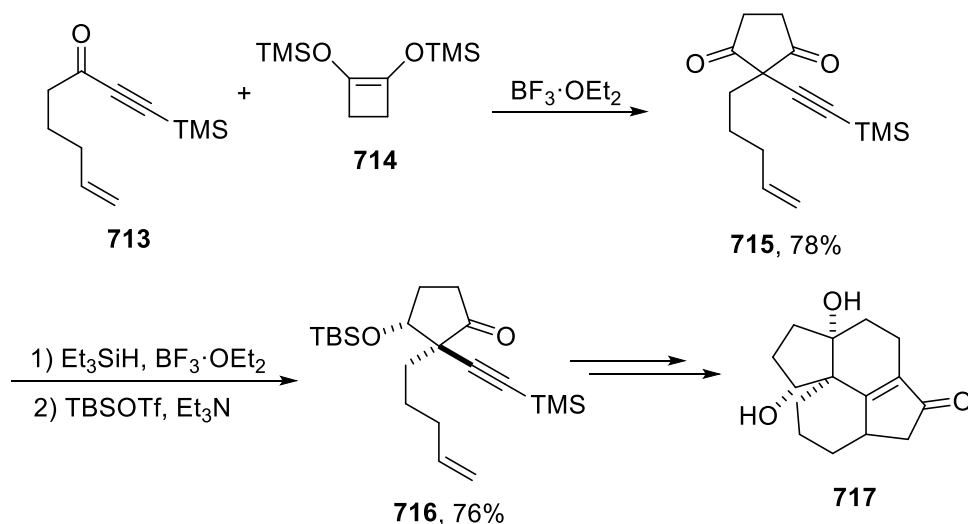

A reductive acylation has been reported for the reaction of ynones with an acid chloride promoted by magnesium metal. Thus, both substrates **71** and an acyl chloride react with Mg in DMF to give mainly conjugated enyne **718** via intermediates **I-IV** resulting from an electron transfer and reaction of the generated anion with the electrophile (Scheme 317).⁵²⁷

Scheme 317. Reaction of Ynones **71** with Acyl Chlorides and Magnesium

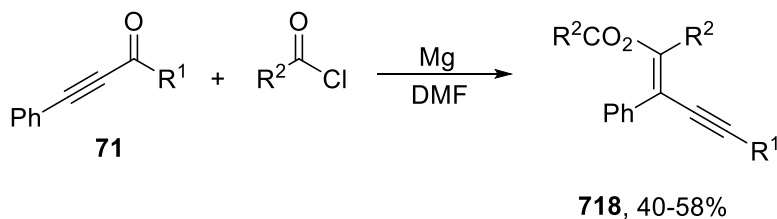

$\text{R}^1 = \text{Me, Et, } n\text{Bu, Cy, Ph, Ph}(\text{CH}_2)_2, 2\text{-furyl}$
 $\text{R}^2 = \text{Me, Et, } n\text{Pr, } n\text{Bu, } i\text{Bu, Cy, Cl}(\text{CH}_2)_3, \text{Ph}$

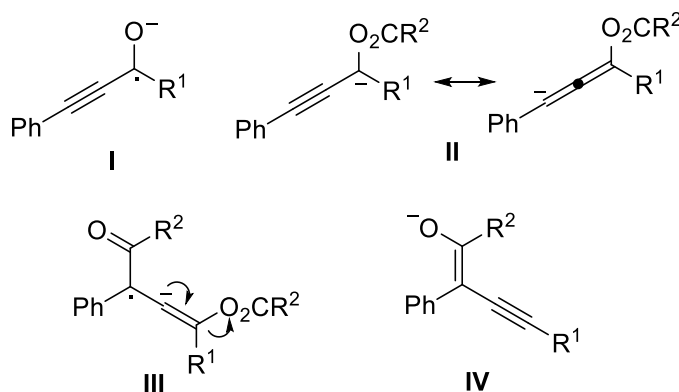

When ynones **71** were allowed to react with malononitrile in toluene at 120 °C polysubstituted anilines **719** were isolated (Scheme 318). The reaction starts with a condensation of both reagents to give intermediate **720**, which suffers a Michael-type

addition affording **721**, that reacts with a third molecule of the dinitrile to yield **722**, a direct precursor of the final product **719**.⁵²⁸

Scheme 318. Preparation of Substituted Anilines 719 from Yrones 71

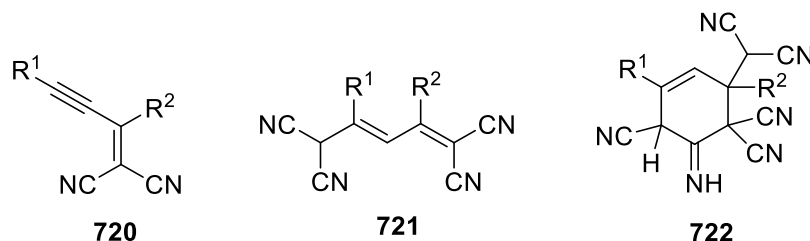
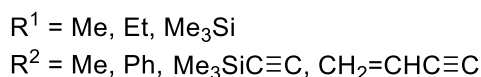
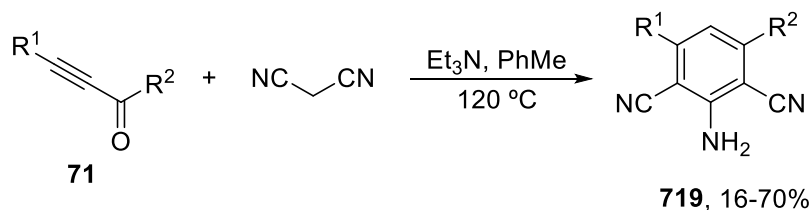

In the way to prepare polyynes, Tykwinski and co-workers reacted silylated yrones **16** with CBr₄ in the presence of PPh₃, so the corresponding enynes **723** were prepared, which after desilylation gave deprotected compounds **724** (Scheme 319). These products could be easily transformed into dienyne ketones **725** through a three-step process including (a) a Fritsch-Buttenburg-Wiechell (FBW) rearrangement giving a lithium acetylide; (b) lithium/tin transmetalation to afford the corresponding tin acetylide; and (c) a Stille coupling reaction.⁵²⁹

Scheme 319. Transformation of Yrones 16 into Diynes 725

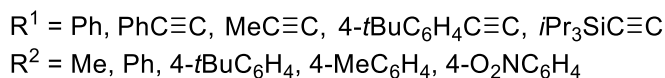
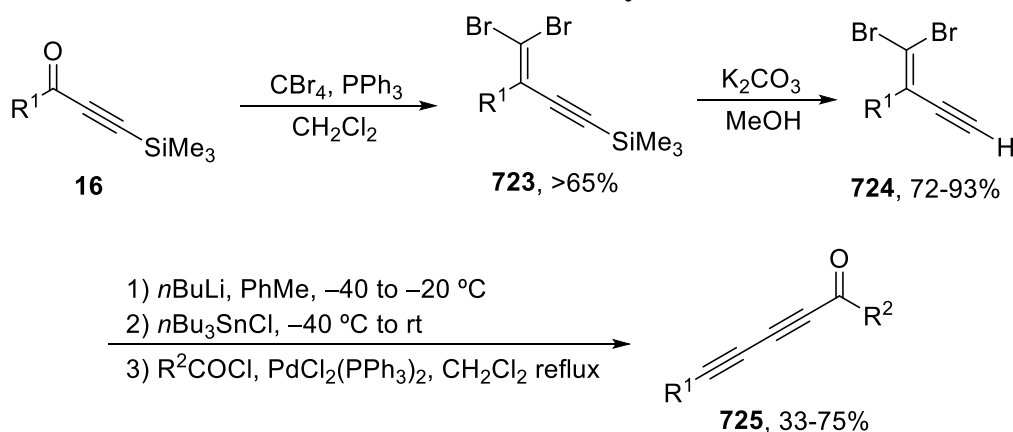

When the ynone contains an ester functionality at the α -position as in **187**, its reaction with 1,3-diketones in the presence of catalytic amounts of silver triflate and (*R*)-BINAP

allows the direct synthesis of chiral substituted dihydrofurans (**726**) (Scheme 320). These compounds can be easily transformed into the corresponding furans. The formation of **726** can be explained by a first 1,2-addition to the activated carbonyl group to give the intermediate **727**, which suffers a 6-*exo-dig* cyclization to give the final heterocycles **726**.⁵³⁰

Scheme 320. Reaction of Yrones 187 with 1,3-Diketones to Dihydrofurans 726

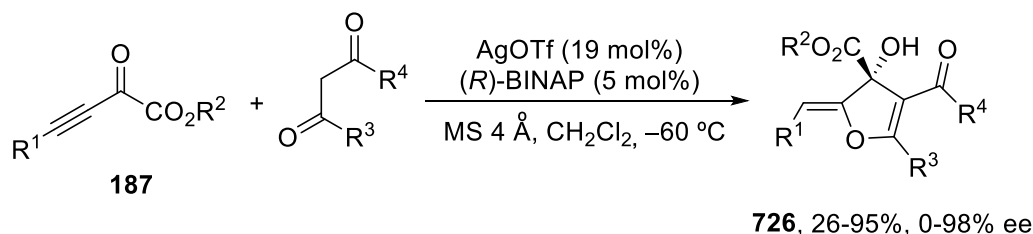

R¹ = Ph, 4-O₂NC₆H₄, 4-BrC₆H₄, 4-FC₆H₄, 4-MeC₆H₄, 2-Me, 4-MeOC₆H₄, 1-naphthyl, 2-thienyl, *n*Bu

R² = Me, Et

R³-R⁴ = CMe₂(CH₂)₂, CH₂CMe₂CH₂, (CH₂)₃, (CH₂)₂; R³ = R⁴ = Me

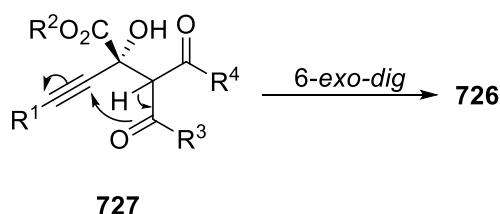

Another type of activated yrones are trifluoromethyl derivatives **363**, which are able to react with substituted indoles in the presence of a catalytic amount of benzoic acid to afford the expected 3-substituted indoles **728** (Scheme 321). When the 3-position is occupied (for instance with a methyl group) the reaction took place at the 2-position, but the yield was lower.⁵³¹

Scheme 321. Preparation of Indoles 728 from Yrones 363

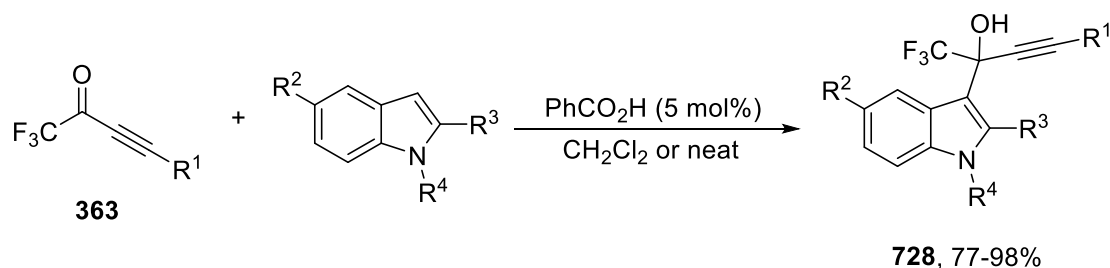

R¹ = *n*Bu, Ph, 4-MeC₆H₄, 4-MeOC₆H₄, 4-ClC₆H₄, 4-MeO₂CC₆H₄

R² = H, Me, MeO, Br, MeO₂C, NC

R³ = H, Me

R⁴ = H, Me

The 3-position of the indole can be activated for nucleophilic attack of an ynone (**16**) by forming the corresponding organolithium intermediate by bromine/lithium exchange.

Thus, starting from bromo derivative **729**, double addition of BuLi allows formation of compounds **730** albeit in low yields (Scheme 322). These compounds were generated by initial nucleophilic addition to the carbonyl group to yield alkoxide **I**, which eliminates lithium oxide and gives enyne **II** that finally added a second molecule of the lithiated indole to afford the obtained reaction product.⁵³²

Scheme 322. Preparation of Compounds 730 from Indole 729 and Ynones 16

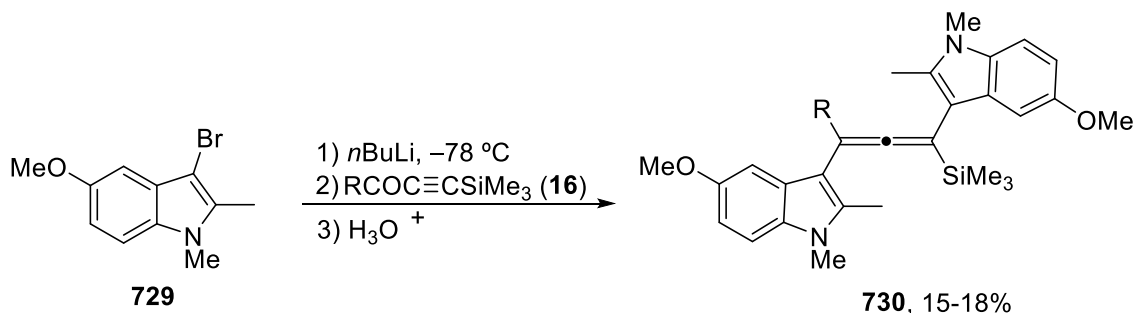

R = Ph, Me₃SiC≡C

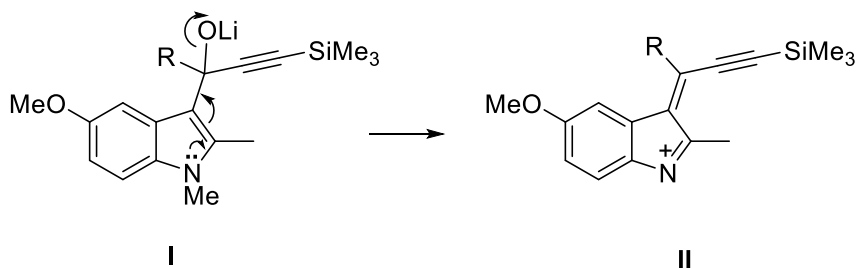

Knight and co-workers reported that the use of a tin enolate derived from glycinate **731** in reactions with ynones **71** in THF at temperatures from -78 °C to room temperature gave mainly *anti*-**732** (Scheme 323). A transition state (**I**) rationalizes the stereochemistry observed in this reaction.³¹⁰

Scheme 323. Preparation of Amino Esters 732 from Ynones 71

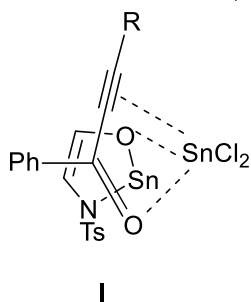
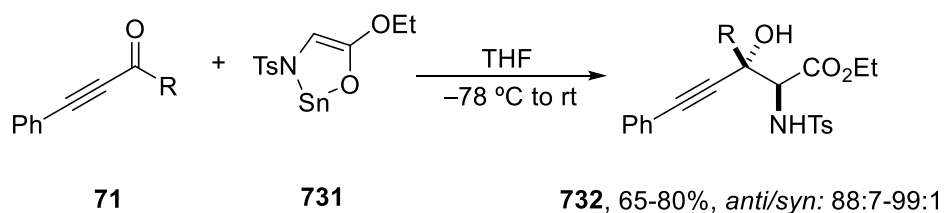

3.4.2. Heteronucleophiles. By applying heteronucleophiles, new carbon-heteroatom bonds are formed and open up new opportunities to prepare a variety of heterocyclic compounds with control of the substitution pattern.

Perumal and co-workers described the preparation of a series of isoxazoles (**379**) in good to excellent by treatment of (*Z*)-oximes (**733**; easily prepared by reaction of the corresponding ynones (**71**) with hydroxylamine) with AuCl₃ in dichloromethane under reflux (Scheme 324).⁵³³ The mechanistic proposal put forward involves intermediates **I** and **II**. Conversion of **I** to **II** requires *Z* geometry and this conceivably explains why attempts to make isoxazoles from (*E*)-oximes failed.

Scheme 324. Preparation of Isoxazoles (379) from Z-Oximes (733)

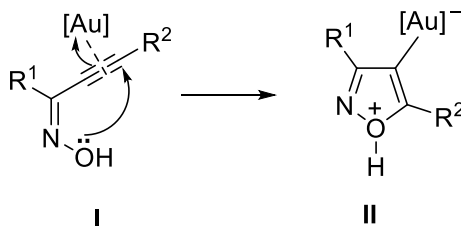
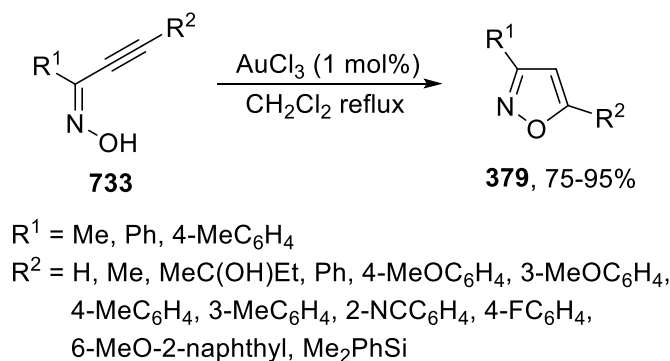

Isoxazoles **379** were also formed as by-products in reactions of mixtures of *Z/E-O*-tosyloximes **734** (easily prepared by treating the corresponding oximes **733** with *p*-toluenesulfonyl chloride and triethylamine) with *in-situ* generated NaSeH (prepared by reaction of elemental selenium with sodium borohydride in ethanol), which mainly gave selenium-containing heterocycles **735** in moderate yields (Scheme 325). The same reaction with tellurium failed.⁴²⁰ The authors propose the intervention of species **I** and **II** in the reaction pathway.

Scheme 325. Preparation of Isoselenazoles 735 from O-Tosyloximes 734

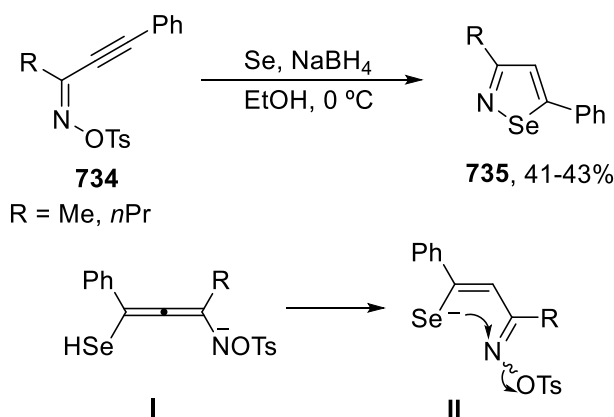

Another heteroatom able to act as nucleophile toward the carbonyl group of an ynone is phosphorous. Thus, enantioselective hydrophosphonylation of ynone **71** has been achieved by *in-situ* generated chiral tetraaminophosphonium chloride **736**, which forms enantioenriched α -hydroxy phosphonates **737** in good to excellent yield (Scheme 326). The intermediacy of species **I-III** has been envisaged to explain the formation of the products.⁵³⁴

Scheme 326. Preparation of Chiral Hydroxy Phosphonates (**737**) from Ynone **71**

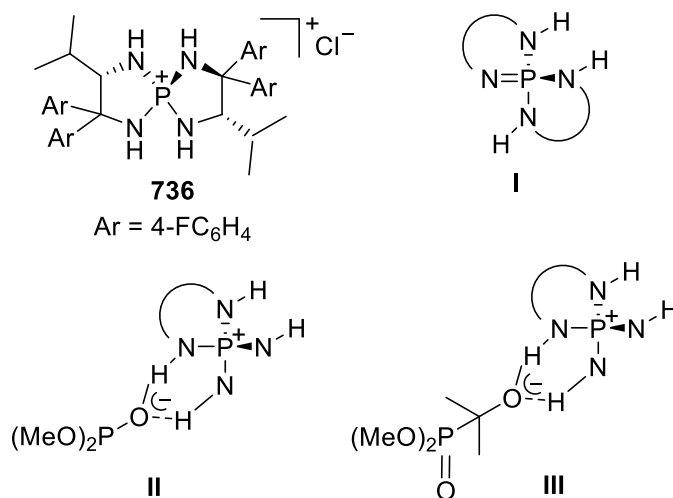
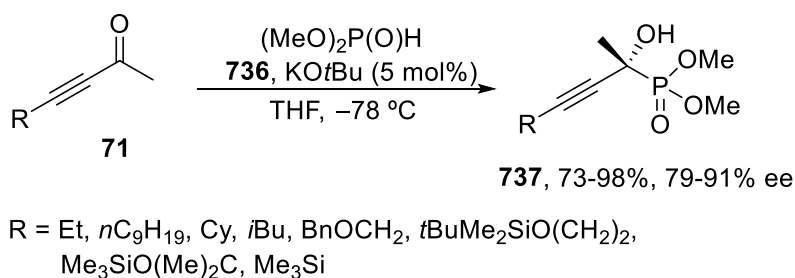

An interesting case of structure-dependent intermolecular cyclization starting from ynone **71** is shown in Scheme 327. In the reaction of alkyl-substituted β -hydroxyethyl azides **738** with ynone, the phosphine-promoted cyclization afforded 1,4-oxazepines (**739**), whereas with aryl-substituted analogues **740** the corresponding 1,3-oxazines **741**

were obtained under the same reaction conditions. This different behavior can be explained considering an initial imine formation giving intermediate **I**, which via a Michael-type addition gives oxazepines **739**. On the other hand, the formation of the corresponding oxazines **741** would involve intermediates **II-IV**.⁵³⁵

Scheme 327. Divergent Preparation of Oxazepines 739 and Oxazines 741

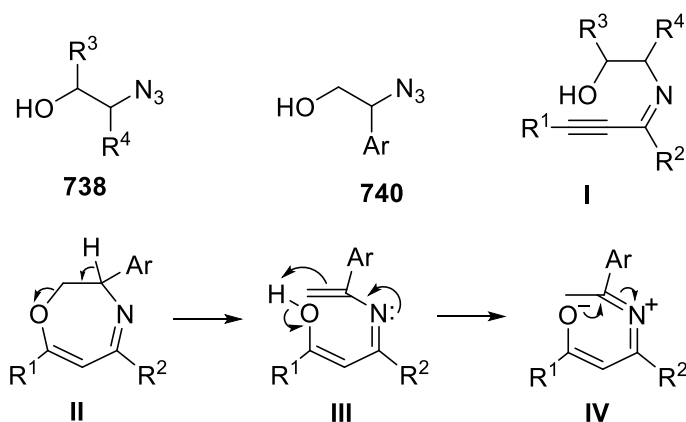
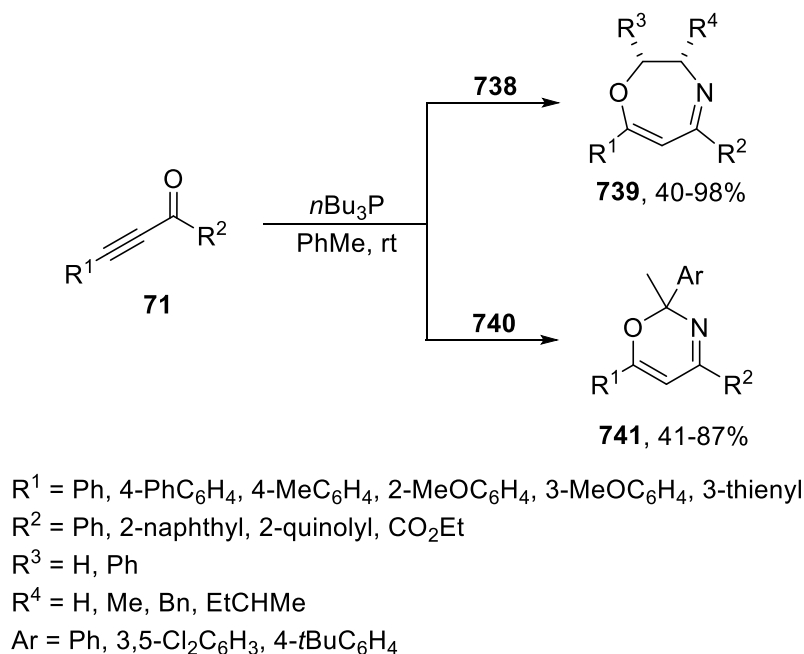

Concerning intramolecular cyclizations, when Boc-protected chiral amino ynones **742** (easily prepared from L-pyrroglutamic acid) were treated with a dichloromethane solution of MeSO_3H at room temperature, heterocycles **743** were formed due to a cyclization followed by a Meyer-Schuster rearrangement (Scheme 328). Intermediates **I** and **II** have been postulated to be involved in the process. It is noteworthy that *E*-**743** easily isomerizes to the corresponding *Z*-isomer by acid-base treatment.⁵³⁶

Scheme 328. Cyclization of Ynones 742 to Give Chiral Pyrrolidines 743

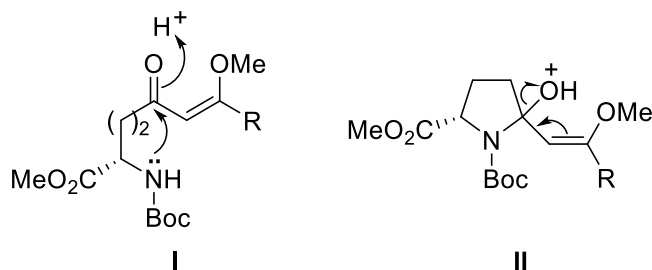
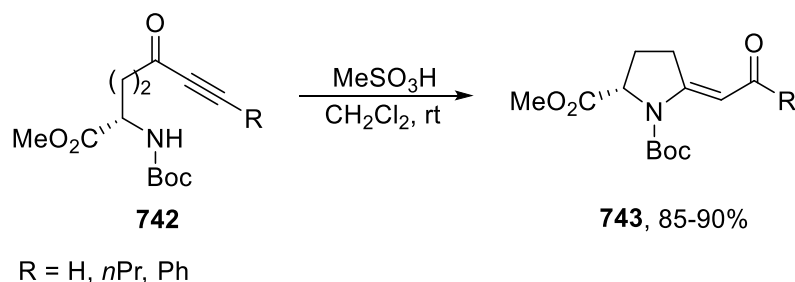

The same group has also reported the intramolecular cyclization of amino ynones **742** promoted by zinc dichloride in diethyl ether at room temperature to give acetylenic cyclic imines **744** in variable yields (Scheme 329). In this case, the alcohol initially formed (**745**) suffers dehydration, after deprotection, to afford the final imine.⁵³⁷ This chemistry has also been extended to the corresponding six-membered rings.

Scheme 329. Conversion of Ynones (**742**) into Pyrrolines (**744**)

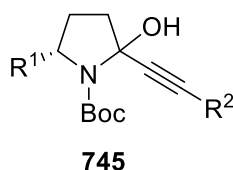
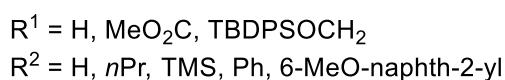
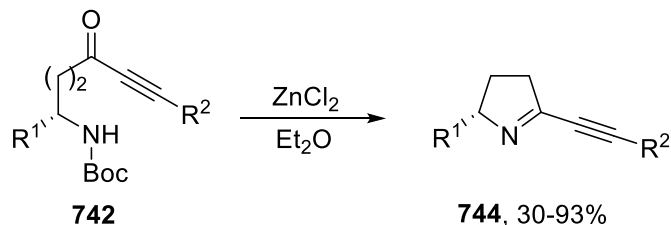

In their study of the synthesis of the antibiotic kendomycin, Tanaka and co-workers utilized the reactivity of the carbonyl group in the ynone moieties in **746** and **747** to construct the tetrahydropyran ring required to reach the goal. This was achieved by regioselective reduction to the corresponding secondary alcohols, followed by deacetalization and diol formation, and completed by dehydration and ether formation to give products **748** and **749**, respectively (Scheme 330).⁵⁹ The overall yields correspond to a yield of about 75% in each step.

Scheme 330. Formation of Tetrahydropyran Derivatives 748 and 749

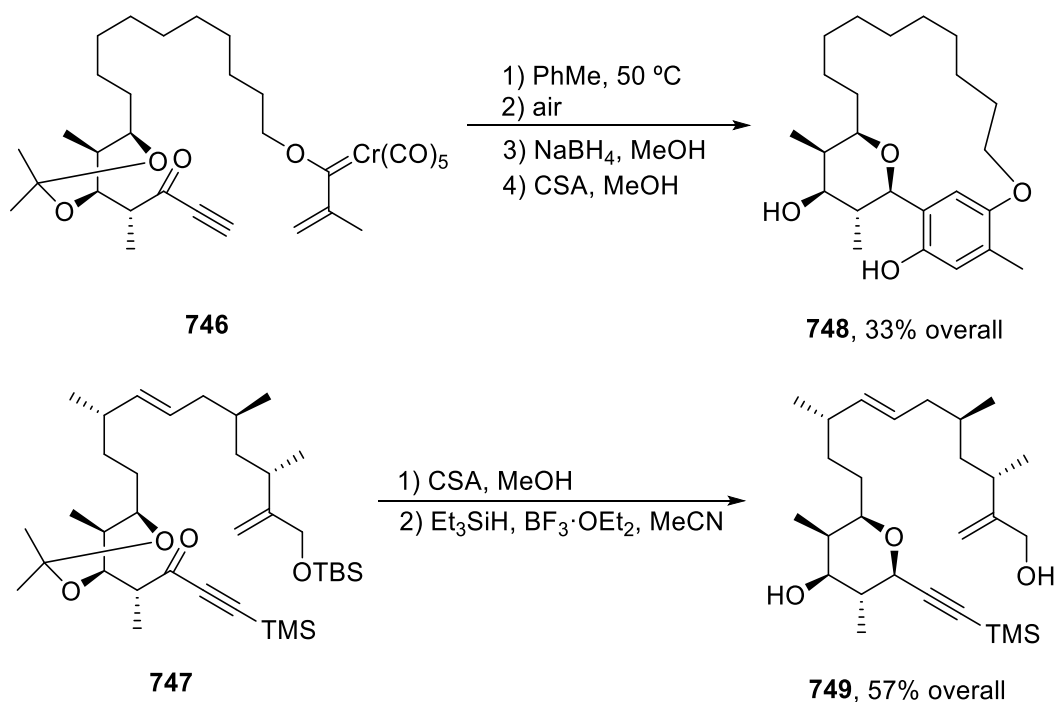

3.4.3. Reductions. Most of the methodologies developed for the selective reduction of the carbonyl group of ynones are based on boron reagents and hydrogen transfer processes.

3.4.3.1. Boron Reagents. The complex $\text{BH}_3 \cdot \text{SMe}_2$ combined with the so-called Corey-Bakshi-Shibata (CBS) catalyst (*R*)-**750** in THF reduced selectively the carbonyl group of ynone **59** to give the propargyl alcohol (*R*)-**751** with excellent result (Scheme 331). Using the catalyst (*S*)-**750** the corresponding (*S*)-product was obtained.⁶¹

Scheme 331. Selective Reduction of Ynone 59 to Alcohol 751

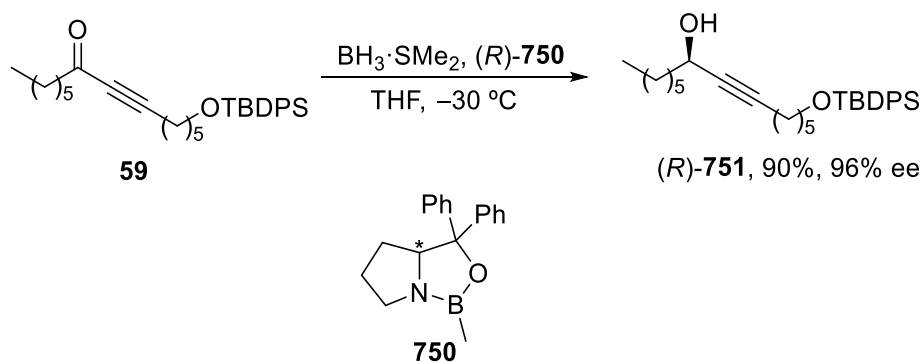

Furthermore, (*S*)-**750** together with $\text{BH}_3 \cdot \text{DMF}$ resulted in efficient conversion of the ynone moiety in **752** to the corresponding propargylic alcohol in **753** (Scheme 332).⁵³⁸

Scheme 332. Transformation of the Ynone 752 into the Alcohol 753

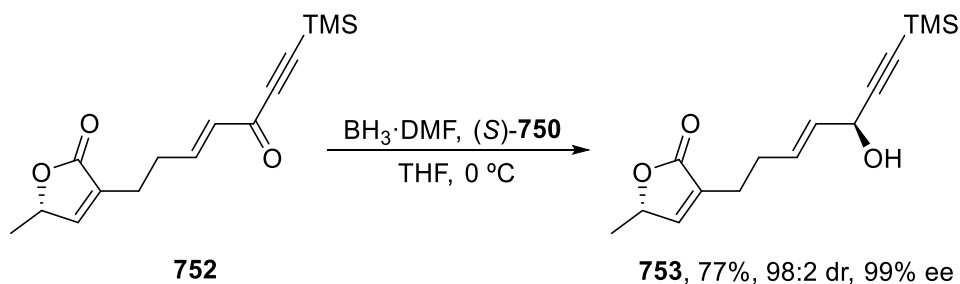

Also, catalyst (*S*)-**750** was used in combination with catecholborane (**755**) in nitroethane for the selective reduction of ynones **754** with a propargylic methoxy group to the corresponding enantioenriched propargylic alcohols **756** with excellent results (Scheme 333).⁵³⁹

Scheme 333. Reduction of Ynones 754 to Chiral Alcohols 756

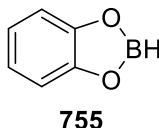
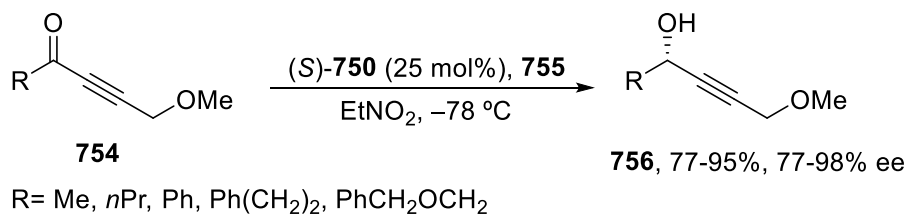

In the case of the terminal ynone **757** its transformation into the (*R*)-alcohol **759** was carried out with (*R*)-Alpine borane ((*R*)-**758**) in THF at $-10\text{ }^\circ\text{C}$ (Scheme 334). This reduction introduced the first stereocenter in the total synthesis of the alkaloid (–)-stemospirone.⁵⁴⁰

Scheme 334. Reduction of Ynone 757 to Alcohol 759

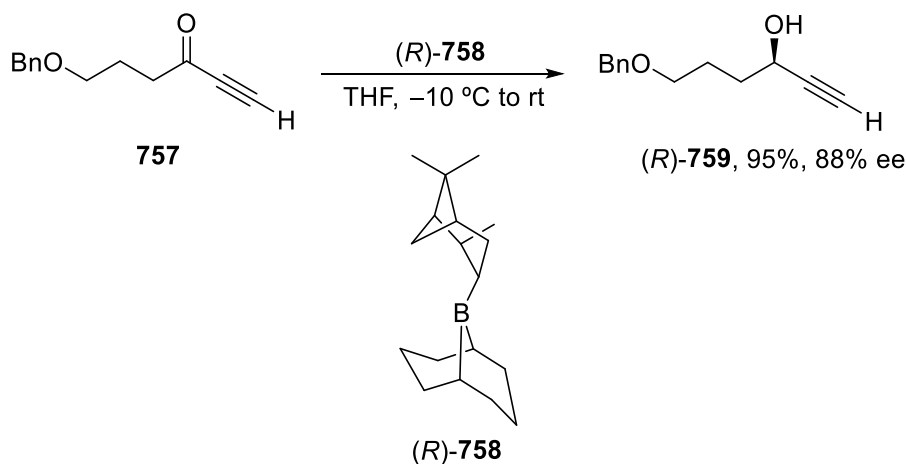

A key step in the total synthesis of (+)-phomopsidin used a combination of α -pinene and 9-borabicyclo[3.3.1]nonane (9-BBN) in THF at room temperature for the reduction of ynone **83** to the corresponding alcohol (**760**) (Scheme 335).⁸⁷

Scheme 335. Reduction of the Ynone 83 to the Alcohol 760

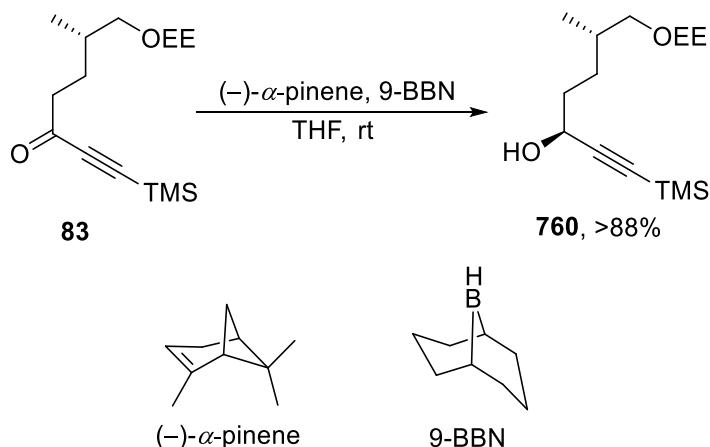

The enantiomeric boron reagent (*S*)-Alpine borane ((*S*)-**758**) shown in Scheme 334 was used to convert ynone **71** to the corresponding alcohol with *S* configuration ((*S*)-**761**) (Scheme 336).⁵⁴¹

Scheme 336. Reduction of Ynone 71 to the Propargylic Alcohol 761

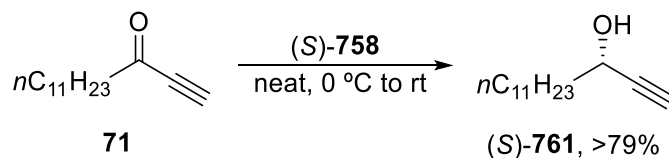

A combination between L-TarB-NO₂ (**762**) and NaBH₄ was used for the selective reduction of ynones **71** in THF at room temperature to give the corresponding alcohols **70** (Scheme 337). The variation in ee was significant (6-90%), and a lot of experimental and computational work was done sort out the reasons for this considerable substituent impact.⁵⁴²

Scheme 337. Reduction of Ynones 71 to Alcohols 70

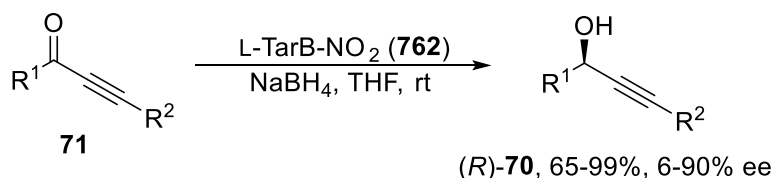

$R^1 = \text{Me, Et, } i\text{Pr, } t\text{Bu, Cy, Ph, 3-furyl}$

$R^2 = n\text{Bu, Ph, TMS}$

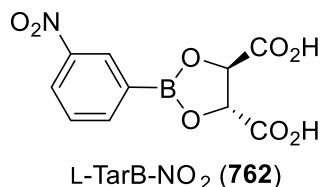

3.4.3.2. Hydrogen Transfer. In order to avoid the use of dangerous molecular hydrogen, the hydrogen-transfer technology is carried out using isopropanol or formic acid as the hydrogen source in combination with a transition metal catalyst.

When *i*PrOH is used, the most useful catalyst is the Noyori's catalyst **763**. For instance, in the preparation of an appropriate substrate for a ring-closing metathesis, ynone **97** was reacted with (*S,S*)-**763** and *i*PrOH at room temperature to give the expected alcohol **764** (Scheme 338).⁹³

Scheme 338. Reduction of Ynone 97 to Alcohol 764

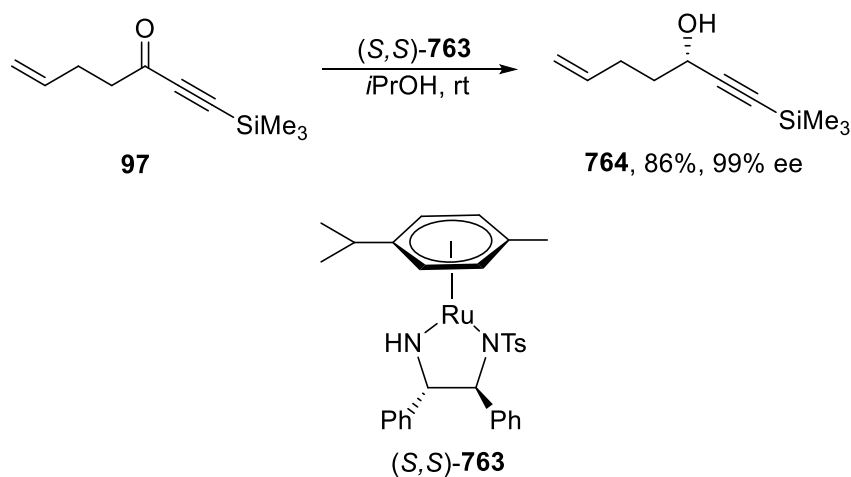

The same catalyst (or its enantiomer) was successfully used for the transformation of ynones **16**,²⁵ **115**,¹⁰⁵ **61**⁶⁴ and **9**¹⁹ into the corresponding chiral alcohols **765-767** and **8**, in all cases using *i*PrOH as the hydrogen source. This step has been of great importance for the introduction of new stereocenters in many molecules (Scheme 339).

Scheme 339. Transformation of Ynones 9, 16, 61 and 115 into Alcohols 8, 765-767

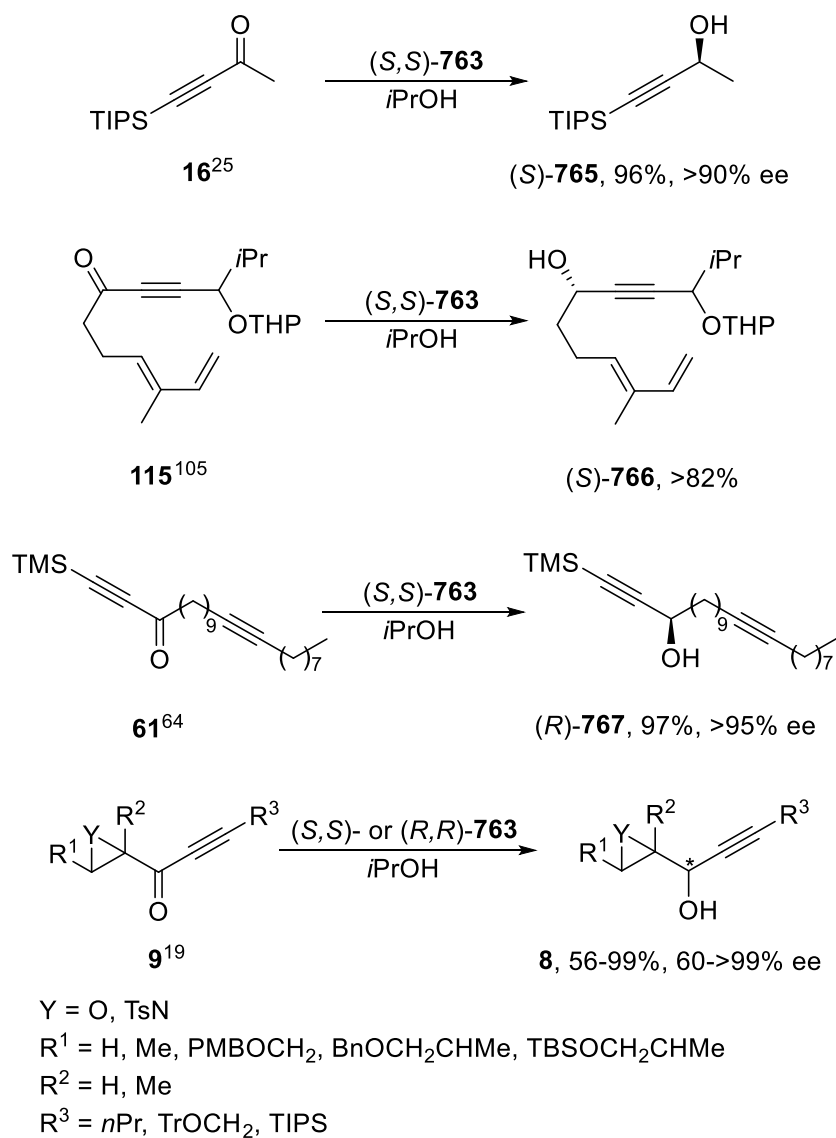

When the source of hydrogen was formic acid, the catalyst was in all cases Noyori's catalyst (**763**) or its analogue **768**. Scheme 340 presents the use of this technology for the enantioselective^{26,94,120,543} or diastereoselective⁶⁰ hydrogenation of ynones **98**,⁹⁴ **26**,²⁶ **131**,¹²⁰ **769**,⁵⁴³ and **770**⁶⁰ to yield chiral alcohols **771-775**, respectively, which have been used in several total syntheses of natural products.

Scheme 340. Hydrogen-Transfer Reduction of Ynones 26, 98, 131, 769 and 770

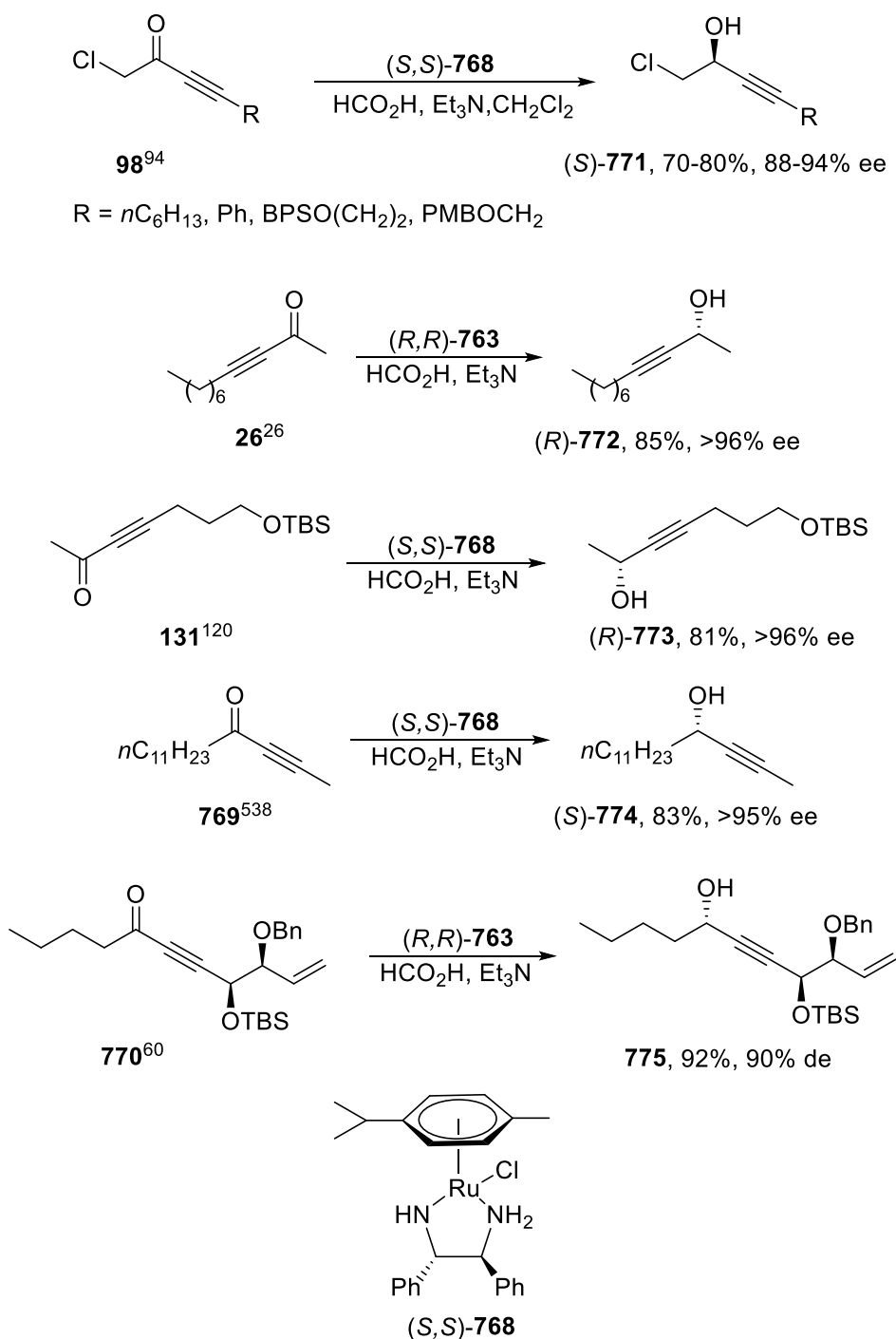

3.4.3.3. Other Reagents. The reduction of both functionalities, namely the carbonyl group and the triple bond to an *E*-olefin, could be easily performed with lithium aluminum hydride in refluxed THF. Thus, starting from ynones **20** the corresponding racemic alcohols **776** were diastereoselectively obtained (Scheme 341). Dienols of type **776** have been used for the preparation of some natural odorants.²⁹

Scheme 341. Diastereoselective Reduction of Ynones **20 to Alcohols **776****

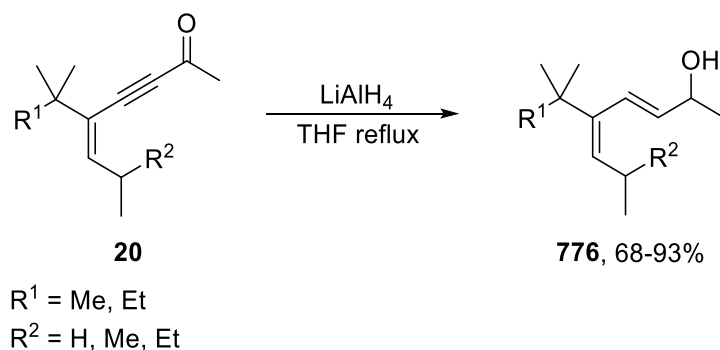

In conclusion, carbon and heteronucleophiles (such as organometallics, aldehydes and stabilized carbanions) have been added to the carbonyl group of ynones in an inter- or intramolecular way, in many cases being applied to asymmetric processes. In addition, the reduction of the C=O bond has been successfully performed using boranes or Ru-catalyzed hydrogen transfer with isopropanol (the last process being especially interesting from a synthetic point of view) for enantioselective reactions.

3.5. Other Reactions

This section is devoted to reactions not included in former sections, such as the aldol reaction, carbo- and heterocyclizations, and isomerization processes, paying special attention to carbon-carbon bond formation reactions.

3.5.1. Aldol Reactions. The enantioselective aldol reaction between ynones (**71**) and isatins (**600**) in the presence of a chiral thiourea (**777**) and CaCl_2 in water at $-10\text{ }^\circ\text{C}$ gave the corresponding chiral tertiary alcohols **778** (Scheme 342). The reaction was extended to acyclic α -keto esters (**779**) with similar results.⁵⁴⁴ Other substituents at the N atom of isatin (Me, $\text{CH}_2=\text{CHCH}_2$, *n*Pr, and Ph) afforded the same yields and enantioselectivities, but the absolute configuration of the new stereocenter was not assigned.

Scheme 342. Transformation of Ynone **71** into Tertiary Alcohols **778**

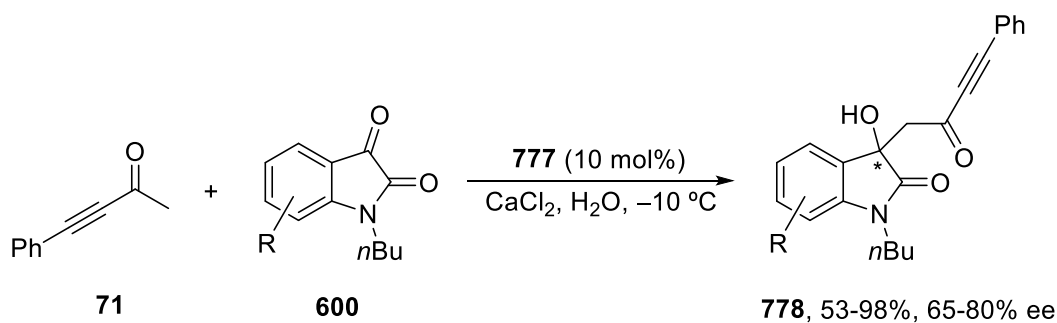

R = H, 4-Cl, 4-Br, 5-Me, 5-F, 5-Cl, 5-Br, 5-O₂N, 5-MeO, 6-Br, 7-F

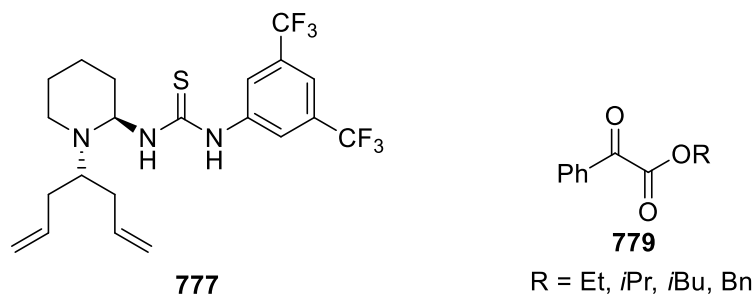

Trost and Quintard⁵⁴⁵ have studied the aldol reaction of ynone **16** with octanal in the presence of Et₂Zn and the chiral ligand ProPhenol (**780**) which furnished dehydrated ketone **781** in good yield (Scheme 343).⁵³⁸

Scheme 343. Aldol Reaction of Ynone 16 with Octanal

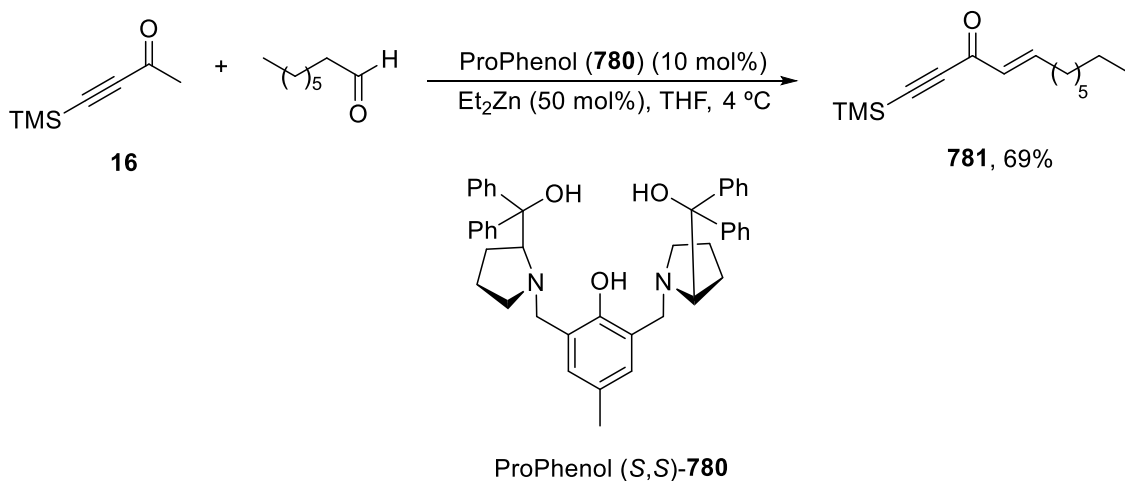

When there is no hydrogen at the α -position of the aldehyde, the corresponding aldol product is isolated. Thus, the reaction of ynone **781** with acetals **782** under the conditions used by Trost and Quintard (Scheme 343) gave aldols **783** with excellent enantioselectivities (Scheme 344).⁵⁴⁶ Reversal of the stereoselection⁵⁴⁷ was observed when the reaction was carried out during only 5 min at 0 °C instead of during 4-24 h at rt.

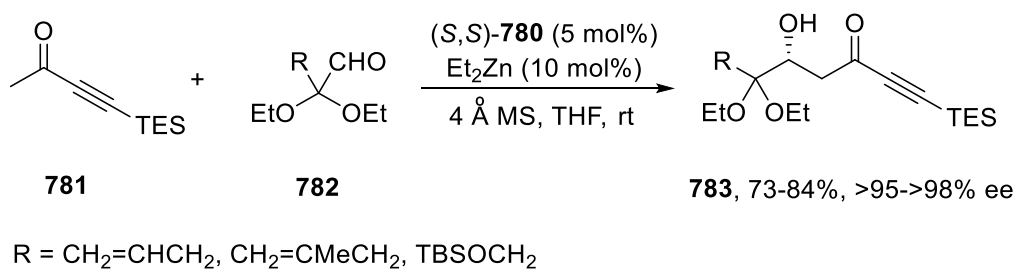
Scheme 344. Enantioselective Aldol Reaction of Ynone 781 and Acetals 782

The same catalytic combination was successfully used by Trost and Hung for catalytic diastereo- and enantioselective Mannich-type reactions. Ynones (**71**) were reacted with protected imines (**784**) in the presence of (*S,S*)-**780** and diethylzinc to give the corresponding β -amino ynones (**785**) with good yields and enantioselectivities (Scheme 345).⁵⁴⁸ Amino ketones **785** are interesting precursors for the preparation of a series of chiral polyfunctionalized molecules, including the total synthesis of (–)-lasubine II. A mechanistic proposal explaining the stereochemistry in **785** has been put forward.

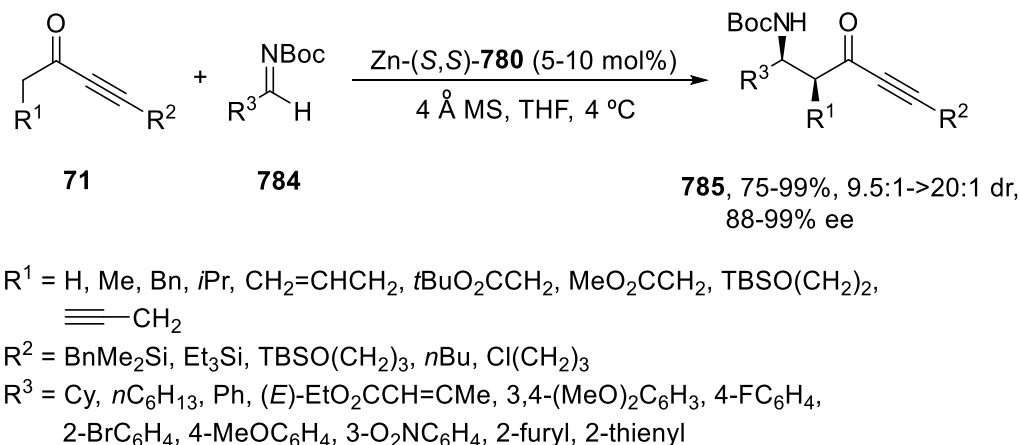
Scheme 345. Mannich-Type Reaction of Ynones 71 with Imines 784

The enantioselective reaction of ynones (**786**) with nitro olefins was performed by Shao, Wang, Peng and co-workers using thiourea **787** as the chiral auxiliary. After one-pot treatment with TsOH the structures of the final products strongly depend on the amount of the acid: with only 0.2 eq of TsOH, nitro ynones **788** were obtained, but when 2 eq were used, nitro diketones **789** were isolated (Scheme 346). A tentative model to explain the stereochemistry has been proposed.⁵⁴⁹

Scheme 346. Divergent Reaction of Ynones 786 with Nitroalkenes

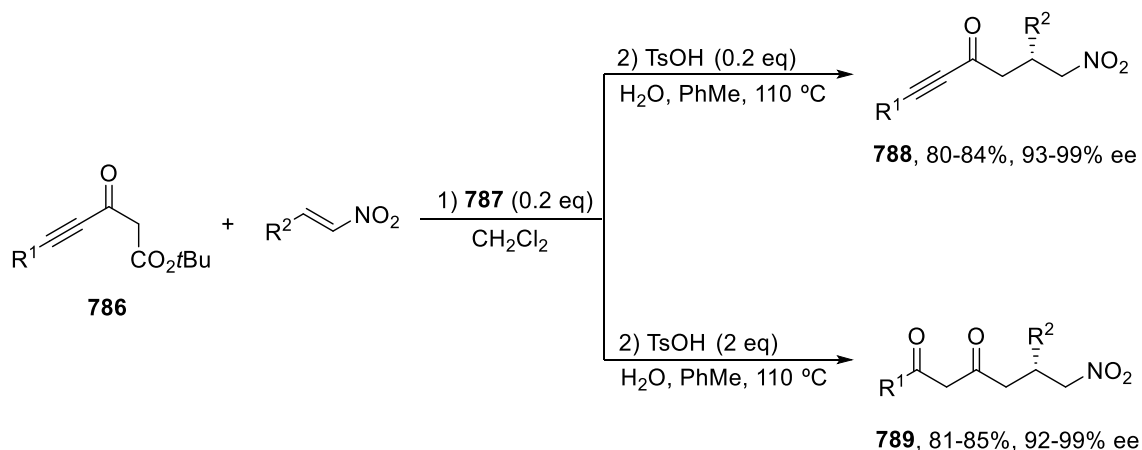

$\text{R}^1 = n\text{Bu}, n\text{C}_6\text{H}_{13}, \text{Ph}, 4\text{-MeC}_6\text{H}_4, 4\text{-FC}_6\text{H}_4$

$\text{R}^2 = i\text{Bu}, \text{Ph}, 4\text{-MeC}_6\text{H}_4, 3\text{-MeC}_6\text{H}_4, 4\text{-MeOC}_6\text{H}_4, 2\text{-MeOC}_6\text{H}_4, 4\text{-BrC}_6\text{H}_4, 2\text{-BrC}_6\text{H}_4,$

$4\text{-F}_3\text{CC}_6\text{H}_4, 2\text{-furyl}, 2\text{-thienyl}$

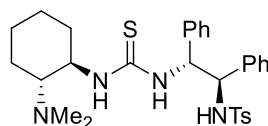

787

3.5.2. Cyclizations. Taylor, Unsworth and co-workers reported the transformation of indolyl ynones **270** into three types of carbocycles, namely spirocycles, carbazoles, or quinolines, depending on the catalyst and the reaction conditions applied (Section 3.1.2.2). Thus, with AgOTf in CH_2Cl_2 at room temperature spiranes **271** were obtained, but with $\text{Ph}_3\text{PAuNTf}_2$ under the same conditions the reaction rendered carbazoles **272**. And application of AgOTf followed by hydrated aluminum trichloride in *i*PrOH at 100 °C afforded quinolines **790** (Scheme 347).³²² Concerning possible mechanisms to explain these results (for $\text{R}^1 = \text{Ph}$, $\text{R}^2 = \text{R}^3 = \text{R}^4 = \text{H}$), the formation of compounds **271** would involve intermediates **I** and **II**, whereas for compounds **272** intermediates **III-IV** conceivably participate. Finally, intermediates **VI-VIII** would explain the formation of compounds **790**.

Scheme 347. Preparation of Spirocycles 271, Carbazoles 272 and Quinolines 790 from Ynones 270

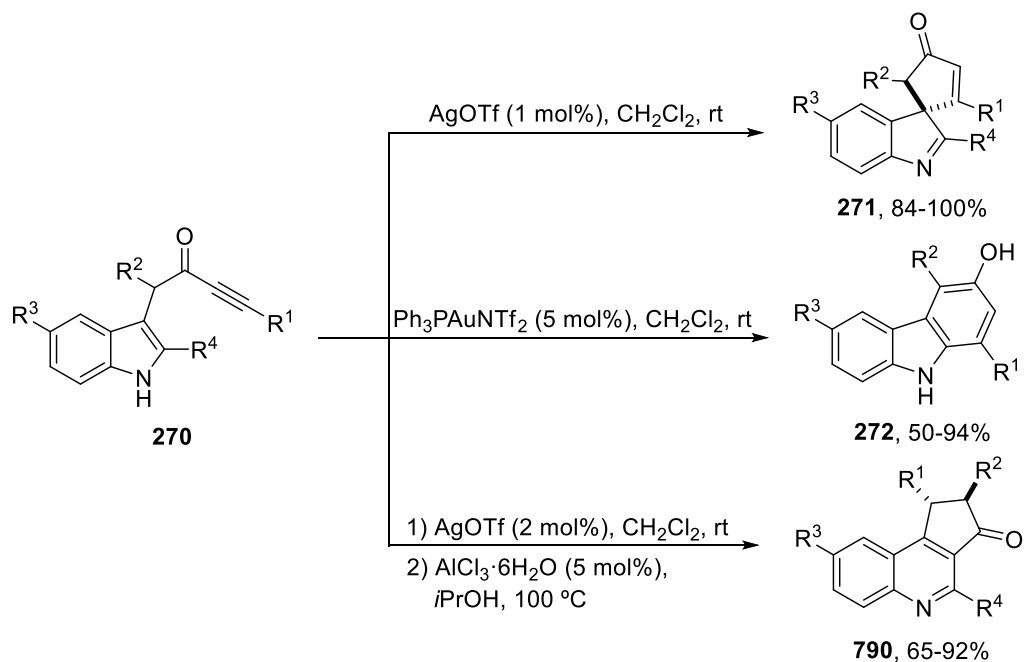

$\text{R}^1 = n\text{Bu}, \text{BocNMe}(\text{CH}_2)_2, \text{TBSO}(\text{CH}_2)_2, \text{TBSO}(\text{CH}_2)_3, \text{Ph}, 4\text{-BrC}_6\text{H}_4, 4\text{-MeOC}_6\text{H}_4, 4\text{-Me}_2\text{NC}_6\text{H}_4$
 $\text{R}^2 = \text{H}, \text{Bn}$
 $\text{R}^3 = \text{H}, \text{Br}$
 $\text{R}^4 = \text{H}, \text{Me}, \text{Ph}, \text{PhS}$

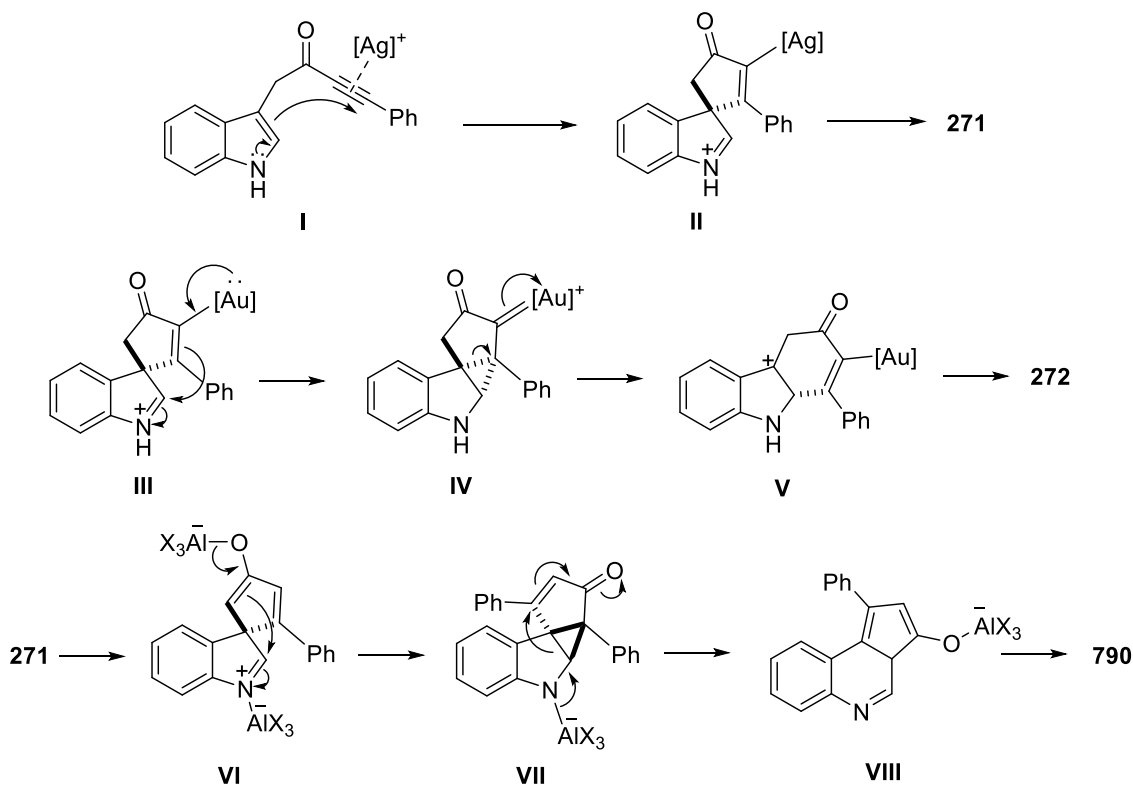

In the case of dienynone **791**, cyclization under optimized conditions using a Rh catalyst and (*R*)-BINAP in combination with AgBF_4 yielded cyclopentanone **792** with excellent results (Scheme 348). This product was converted to a PGJ₂ prostaglandin derivative in six more reaction steps.⁵⁵⁰

Scheme 348. Enantioselective Cyclization of Ynone 791 to Cyclopentanone 792

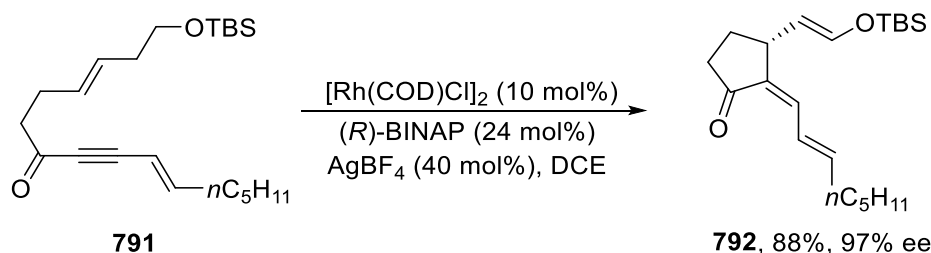

Wender and co-workers⁵⁵¹ reported the one-pot intermolecular cycloaddition of ynones (**793**) with vinylcyclopropane **794** followed by Nazarov cyclization to give cyclopentenones **796** (Scheme 349). In the first process a Rh-catalyzed cycloaddition took place giving dienones **795**, which underwent the Nazarov reaction under Ag-catalysis. The transformation can be also performed in a sequential mode isolating dienones **795** in good yields (65-95%).

Scheme 349. Intermolecular [5+2] Cycloaddition/Nazarov Reaction of Ynones (793) with Vinylcyclopropane 794

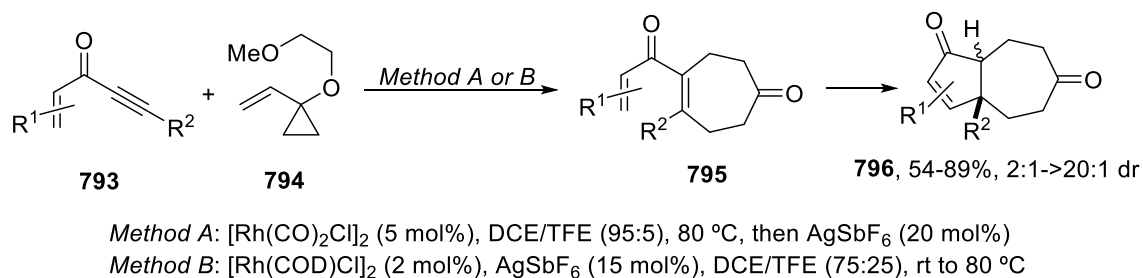

Ynones

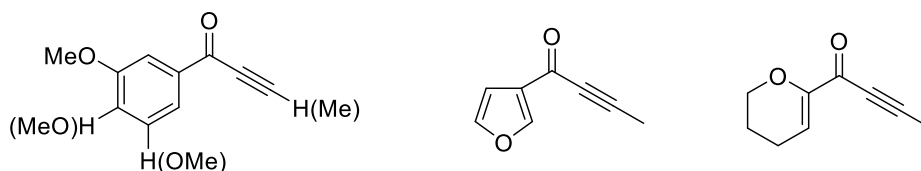

Cyclic *N*-sulfimines (**797**) also react with ynones (**71**) in the presence of chiral organocatalyst **798** and 2-fluorobenzoic acid in toluene at room temperature to yield enantioenriched piperidinones (**799**) in good yields with good enantioselectivity (Scheme 350).⁵⁵²

Scheme 350. Preparation of Piperidinones (799) from Ynones (71)

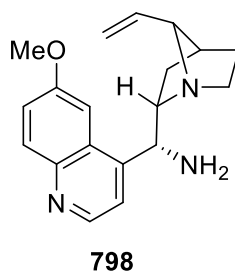
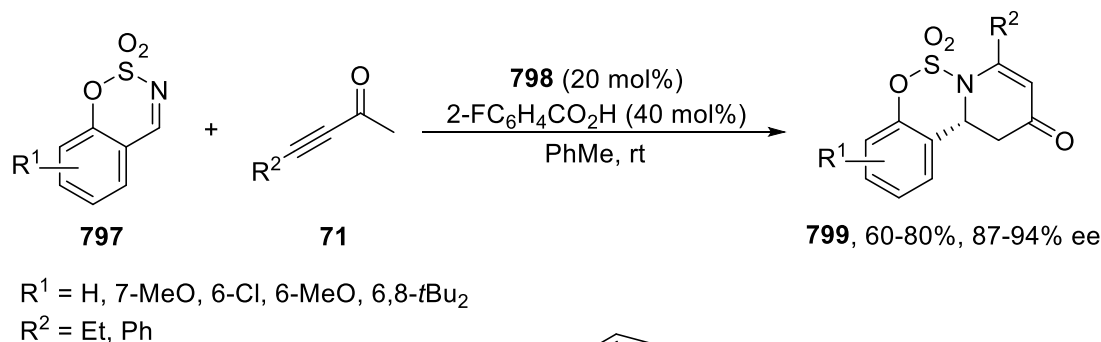

A simple access to chiral spiroindoles (**800**) was reported by Ramachary and co-workers who used the catalyst mixture shown in Scheme 351 to react ynones (**71**) with isatin derivatives (**605**) (Scheme 351).⁴⁷⁴ A complex transition-state model was proposed to explain the observed stereochemistry.

Scheme 351. Enantioselective Preparation of Spirocompounds (800**) from Ynones (**71**) and Oxindoles (**605**)**

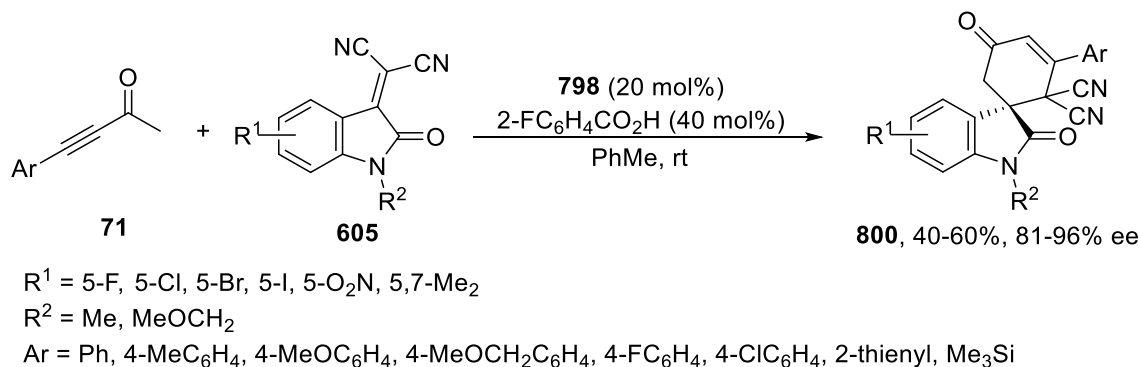

Guo, Zheng and co-workers reported the phosphine-promoted [3+2] annulations of barbiturate-derived alkenes (**801**) with ynones (**71**) in the presence of phenol to afford spirocompounds (**802**) (Scheme 352). The asymmetric version of this reaction using a chiral phosphine gave poor enantioselectivity.⁵⁵³ A possible mechanism for the reaction was envisaged to involve intermediates **I-V** for a model with $\text{Ar}^1 = \text{Ar}^2 = \text{Ph}$.

Scheme 352. Reaction of Ynones (71**) with Barbiturate-Derived Alkenes (**801**)**

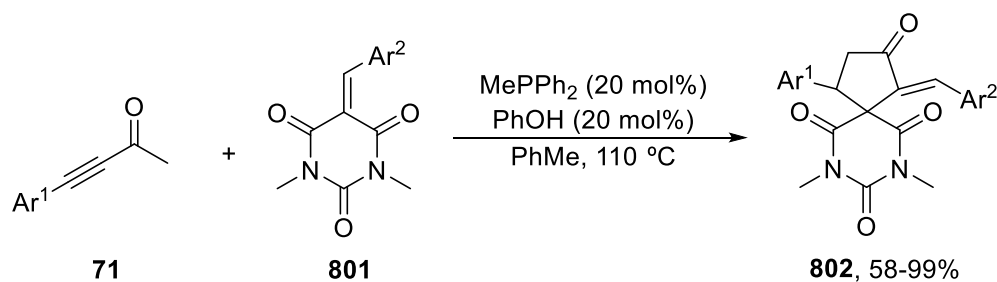

Ar¹ = Ph, 2-MeC₆H₄, 3-MeC₆H₄, 4-MeC₆H₄, 4-EtC₆H₄, 4-*n*PrC₆H₄, 4-*n*BuC₆H₄, 4-MeOC₆H₄, 4-FC₆H₄, 3-ClC₆H₄, 4-ClC₆H₄

Ar² = Ph, 2-MeC₆H₄, 3-MeC₆H₄, 4-MeC₆H₄, 2,4-Me₂C₆H₃, 4-EtC₆H₄, 2-MeOC₆H₄, 3-MeOC₆H₄, 4-MeOC₆H₄, 2-FC₆H₄, 4-FC₆H₄, 2-ClC₆H₄, 3-ClC₆H₄, 4-ClC₆H₄, 3,4-Cl₂C₆H₃, 4-BrC₆H₄, 4-F₃CC₆H₄, 4-NCC₆H₄, 2-O₂NC₆H₄, 1-naphthyl, 2-naphthyl, 2-furyl

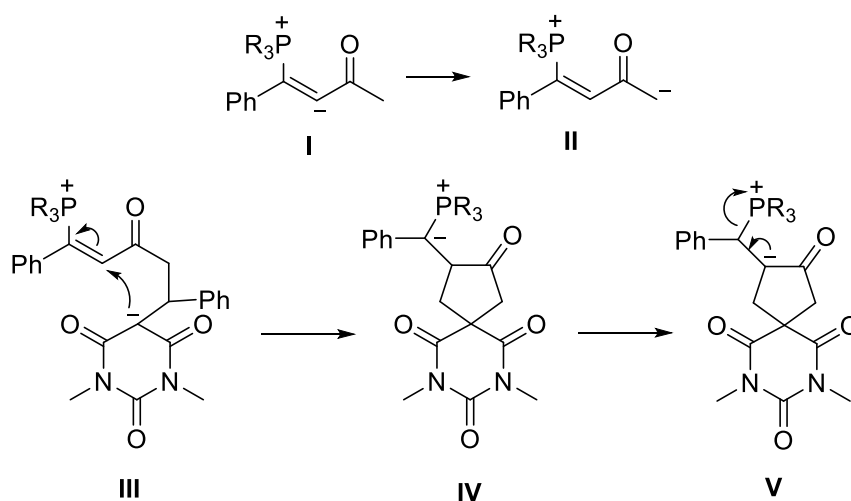

The group of Ji studied the annulation of several ynones (**803**) with quinoline *N*-oxides (**62**) promoted by iodine in DMSO at 130 °C to give phenanthrene derivatives (**804**) (Scheme 353). A rather complicated mechanism has been proposed for this reaction.⁵⁵⁴

Scheme 353. Conversion of Ynones (**803**) to Phenanthrenes (**804**)

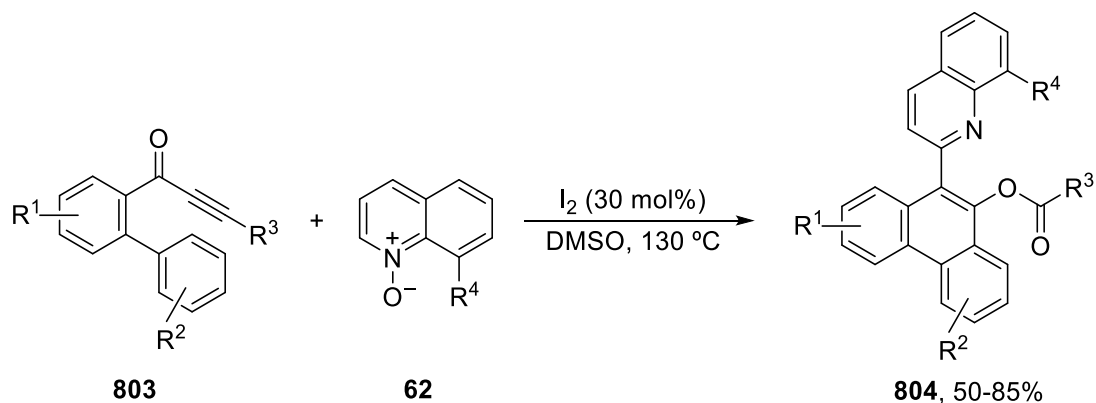

$R^1 = \text{H, 2-MeO, 3-F}$

$R^2 = \text{H, 4-MeO}$

$R^3 = \text{cC}_3\text{H}_5, \text{Ph, 4-MeOC}_6\text{H}_4, \text{3,4,5-(MeO)}_3\text{C}_6\text{H}_2, \text{2-MeC}_6\text{H}_4, \text{2-BrC}_6\text{H}_4$

$R^4 = \text{H, Me}$

Some 5-membered oxygen-containing heterocycles, namely tetronic acid derivatives **806**, were prepared by silver-catalyzed carbonation of ynones (**71**) in the presence of a base (**805**) (Scheme 354). The mechanism assumes the formation of an enolate (**I**) which captures CO_2 and forms an intermediate that is activated by silver (in **II**) and cyclizes to **III**, a precursor to **806** which is formed by abstraction of a hydrogen from the protonated base.⁵⁵⁵

Scheme 354. Carbonation of Ynones (**71**) to Give Lactones **806**

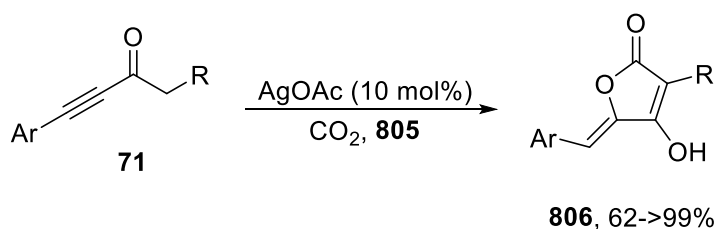

$\text{Ar} = \text{Ph, 2-MeC}_6\text{H}_4, \text{3-MeC}_6\text{H}_4, \text{4-MeC}_6\text{H}_4, \text{4-MeOC}_6\text{H}_4, \text{4-NCC}_6\text{H}_4$

$\text{R} = \text{H, Me, } i\text{Pr, Cy, } n\text{C}_6\text{H}_{13}, \text{Ph}$

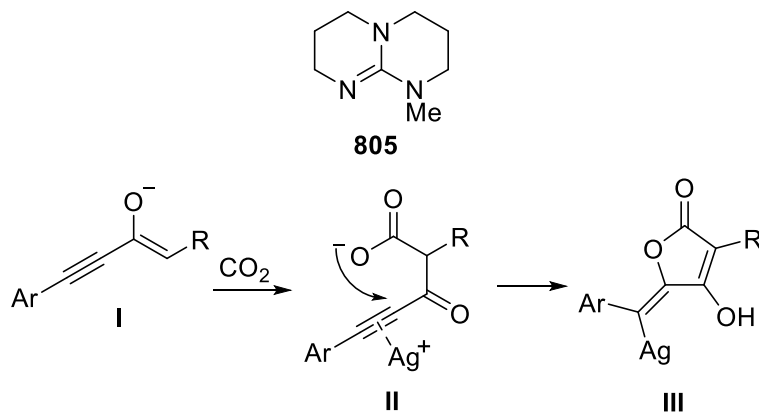

A two-step reaction of ynones **71** with 4-substituted benzaldehydes in the presence of a chiral catalyst **807** afforded enantioenriched dihydroxy ynone derivatives **808**, which by treatment with the diphosphine dppp suffer cyclization to give **809**, the precursor of substituted tetrahydrofuranones **810** (Scheme 355).⁵⁵⁶

Scheme 355. Conversion of Ynones (71) to Chiral Tetrahydrofuranones (810)

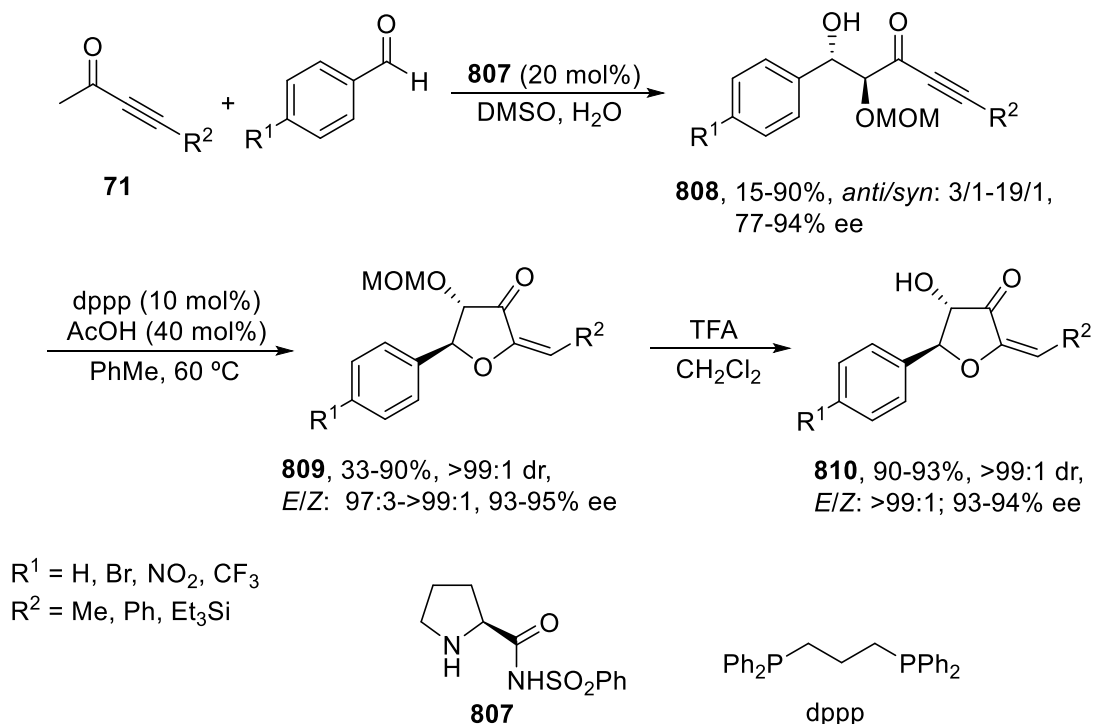

García-Tellado and co-workers reacted ynone **71** with carbonyl compounds in the presence of triethylamine in dichloromethane at -78 °C and obtained 1,3-dioxolanes (**811**) as a mixture of diastereomers (Scheme 356). The possible intervention of intermediates **I** and **II** would explain the obtained results.⁵⁵⁷

Scheme 356. Preparation of Dioxolanes (811) from Ynone 71

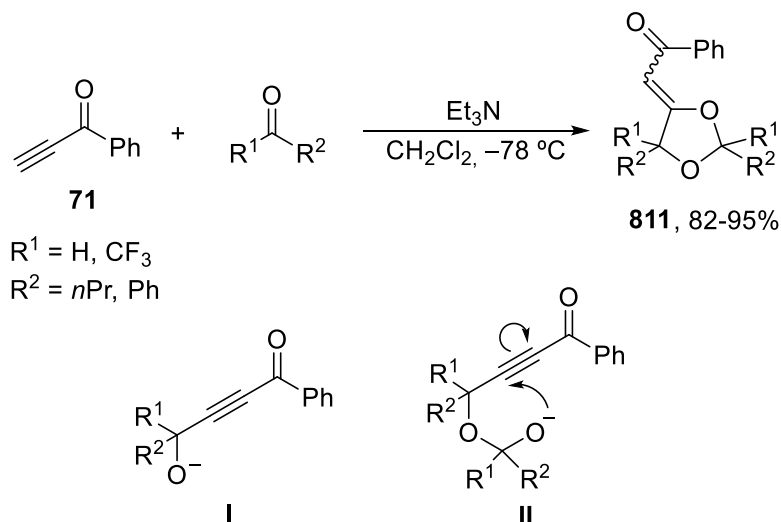

Chiral six-membered oxygenated heterocycles (**462**) could be prepared in a two-step enantioselective process by successive treatment of ynones (**71**) with aldehydes in the presence of copper(I) trifluoroethoxide and the chiral ligand [(*R*)-DTBM-SegPhos] followed by reaction with silver triflate in dichloromethane (Scheme 357). Intermediate **I-III** are believed to take part in the reaction.⁴⁰¹

Scheme 357. Preparation of Dihydropyranones (462) from Ynones (71)

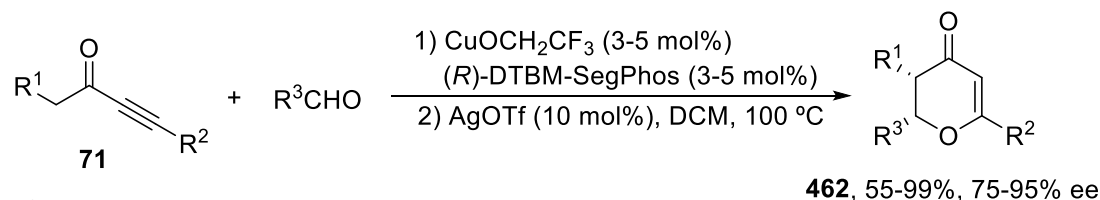

R¹ = H, Me

R² = Me, Et, Ph, HOCH₂

R³ = *i*Pr, Cy, *t*Bu, Ph(CH₂)₂, Ph, 2-naphthyl, *N*-Boc-3-indolyl, 4-EtO₂CC₆H₄, (*E*)-PhCH=CH

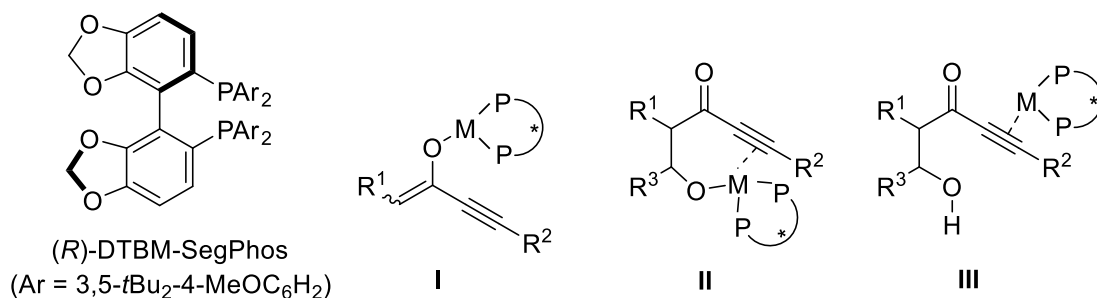

As already mentioned (Section 3.1.3.2.1), Gouverneur and co-workers used the reaction conditions shown in Scheme 357 to prepare dihydropyranones **475** but starting from hydroxy ynones **468** formed in the reaction of ynones **71** with aldehydes (Scheme 358). These hydroxy ynones react with ethyl acrylate to give **475** in a palladium-catalyzed process. Intermediates **I-IV** are believed to be involved in the conversion, and this is in accordance with the observation that when **468** is optically active, the chirality is fully transferred to **475**.⁴⁰⁴

Scheme 358. Conversion of β -Hydroxy Ynones (468) to Compounds 475

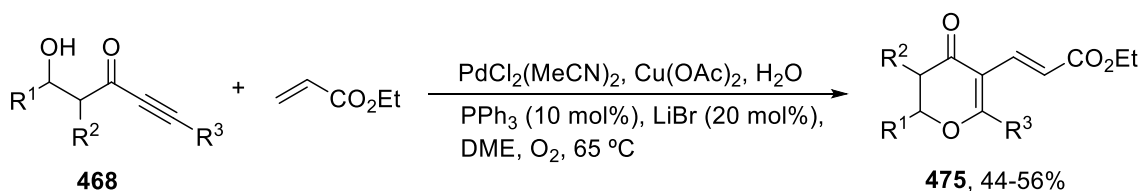

$\text{R}^1 = 4\text{-O}_2\text{NC}_6\text{H}_4, 4\text{-MeOC}_6\text{H}_4$
 $\text{R}^2 = \text{H}; \text{R}^1\text{-R}^2 = (\text{CH})_4$
 $\text{R}^3 = \text{Me, Et}$

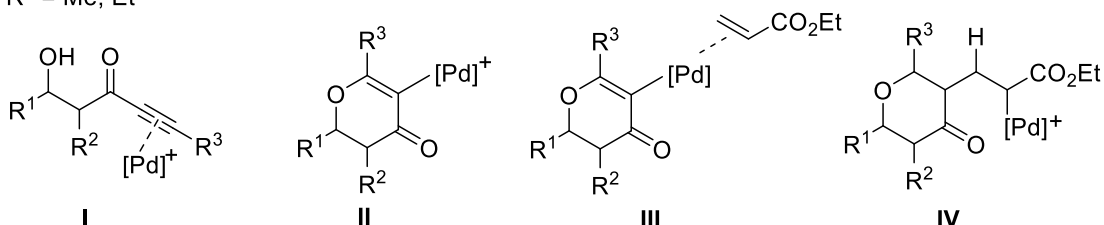

As shown in Scheme 197 (Section 3.1.3.2.1), also eight-membered oxygen-containing rings can be prepared from ynone **71**. These starting materials reacted with α -cyano enones (**449**) in the presence of DABCO in a mixture of ethylene glycol/toluene and gave oxygen heterocycles **450** (Scheme 359). The authors proposed that the reaction involved intermediates **I-IV** in the course of the reactions.³⁹⁷

Scheme 359. Reaction of Ynone (**71**) with Cyanoenones (**449**) to Give Compounds **450**

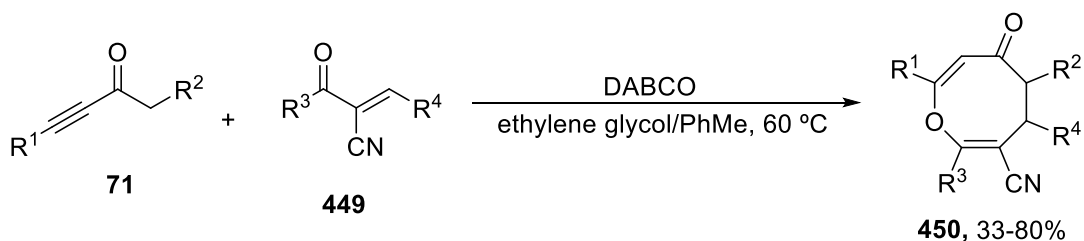

$\text{R}^1 = \text{Ph, } 4\text{-MeC}_6\text{H}_4, 4\text{-FC}_6\text{H}_4$
 $\text{R}^2 = \text{H, Me, Me}_2$
 $\text{R}^3 = \text{Ph, } 4\text{-BrC}_6\text{H}_4, 4\text{-MeC}_6\text{H}_4$
 $\text{R}^4 = \text{Ph, } 4\text{-BrC}_6\text{H}_4, 3\text{-BrC}_6\text{H}_4, 2\text{-BrC}_6\text{H}_4, 4\text{-MeC}_6\text{H}_4, 3\text{-MeC}_6\text{H}_4, 2\text{-MeC}_6\text{H}_4, 4\text{-ClC}_6\text{H}_4, 4\text{-FC}_6\text{H}_4, 4\text{-MeOC}_6\text{H}_4, 2,4\text{-Cl}_2\text{C}_6\text{H}_3, 4\text{-F}_3\text{CC}_6\text{H}_4, 1\text{-naphthyl, } 2\text{-naphthyl, } 2\text{-furyl, } 2\text{-thienyl, Cy}$

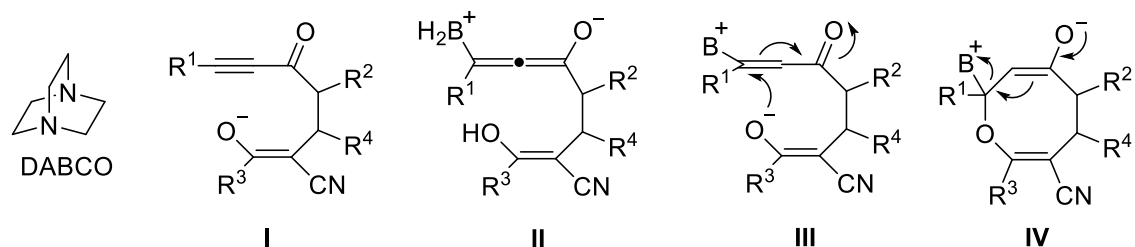

Concerning nitrogen-containing heterocycles, Arcadi, Rossi and co-workers reported on the electro-synthesis of substituted quinolines **304** from electro-generated carbanions derived from nitroalkanes (Section 3.1.2.4), methanol or 1,3-dicarbonyl compounds and

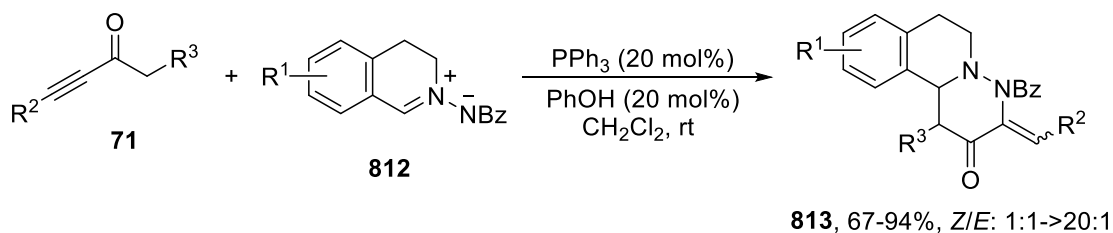

R¹ = H, 5-Me, 7-Me, 8-Me, 7-Cl, 5-Br, 7-Br

R² = Ph, 3-MeC₆H₄, 4-MeC₆H₄, 4-EtC₆H₄, 4-*n*PrC₆H₄, 4-*n*BuC₆H₄, 4-MeOC₆H₄, 3-FC₆H₄, 4-FC₆H₄,
3-ClC₆H₄, 4-ClC₆H₄, 4-BrC₆H₄, 4-NCC₆H₄, 4-PhC₆H₄, 7-MeO-2-naphthyl, 2-thienyl

R³ = H, Me, Et

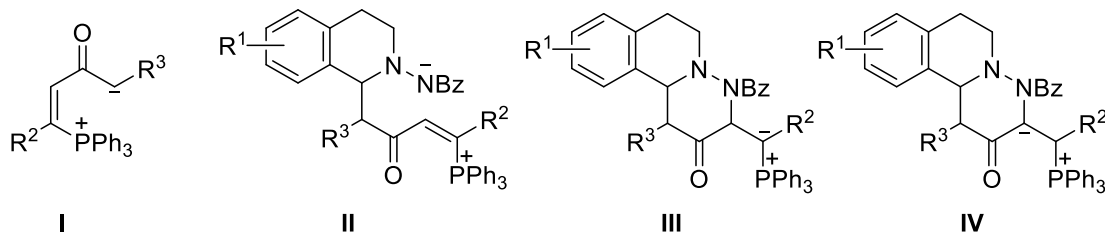

Finally, Patil and coworkers studied the reaction of ynone **814** with 2-aminophenylpyrrole catalyzed by a gold complex (Ph₃PAuOTf), which afforded a tricyclic heterocycle (**815**) in low yield (Scheme 362). The product is what would be expected from a reaction between **815** and acetophenone, which means that the substrate suffered a deep-seated cleavage of the triple bond during the reaction. No mechanistic proof of the transformation was given.⁵⁵⁹

Scheme 362. Surprising Formation of Tricyclic Heterocycle **815** from Ynone **814**

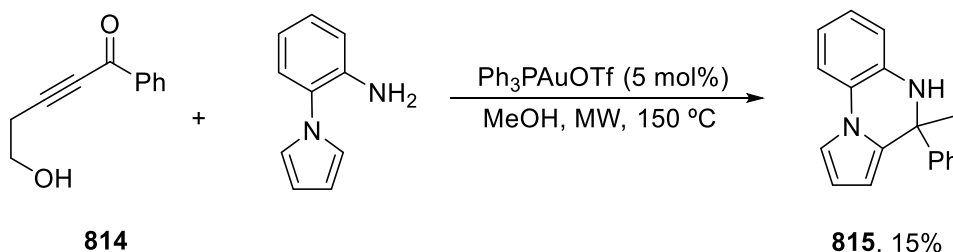

3.5.3. Isomerizations. The conversion of conjugated ynones into $\alpha,\beta,\gamma,\delta$ -dienones by applying phosphines is a well-known transformation that continues to be studied and applied. Jiang and co-workers have used polymeric phosphines such as *JJ*-PP⁵⁶⁰ or PS-TPP⁵⁶¹ to convert ynones **71** into dienyl ketones **816** either under solvent-free conditions or in toluene at 80 °C, respectively (Scheme 363). A noteworthy feature is the observation that the polymer-bound catalyst could be recovered by simple filtration and reused several times with moderate loss of activity, but the catalyst loading had to be kept rather high (20 mol%) and the reaction time long to achieve better than 80% conversion.

Scheme 363. Isomerization of Ynones **71** to Dienones **816**

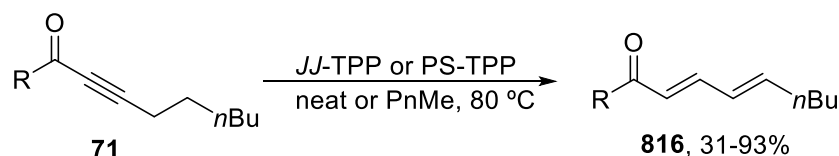

R = Me, *n*Bu, *c*C₆H₁₁, Ph, 4-ClC₆H₄, 4-O₂NC₆H₄, 3-O₂NC₆H₄, 2-furyl

The phosphine-catalyzed isomerization of alkynes to 1,3-dienes has been applied to synthesize a number of natural products. In the synthesis of several macrolactin analogues, Takemoto and co-workers introduced a conjugate dienyl ketone moiety in **817** by successive treatment of the ynone **87** with the diphosphine dppb and acetic acid (Scheme 364).⁸⁸ The same strategy was adopted to obtain the C4-C24 fragment of macrolactin A.⁵⁶²

Scheme 364. Isomerization of the Ynone **87** into Dienone **817**

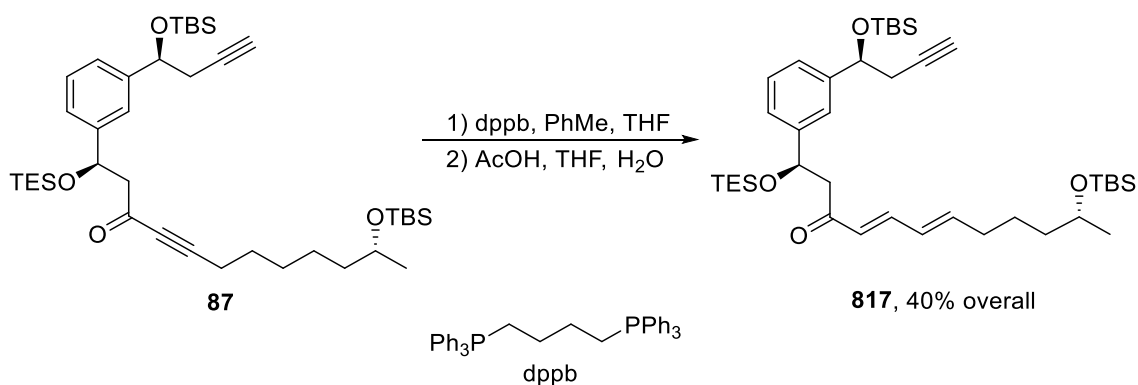

With a different perspective, Ru-complexes were treated with an ynone PhC≡CCOPh (**71**) to afford vinylidene complexes **818**⁵⁶³ and **819**⁵⁶⁴ (Figure 13). The ynone was also reacted with Sc and Lu complexes **820**, but in these cases 1,4-addition occurred and gave dienolates **821** in good yield (Scheme 365).⁵⁶⁵

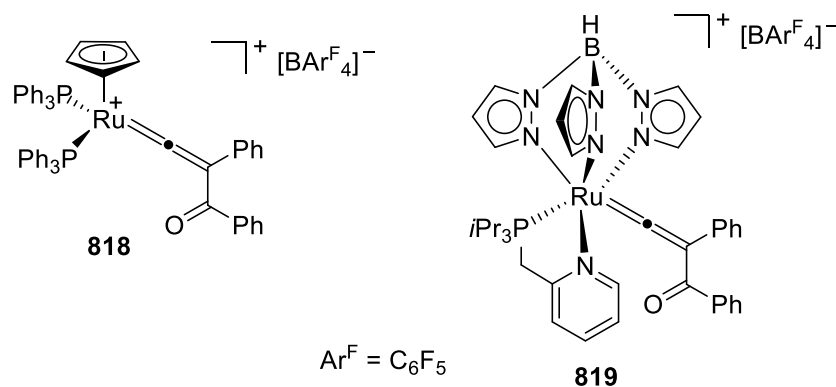
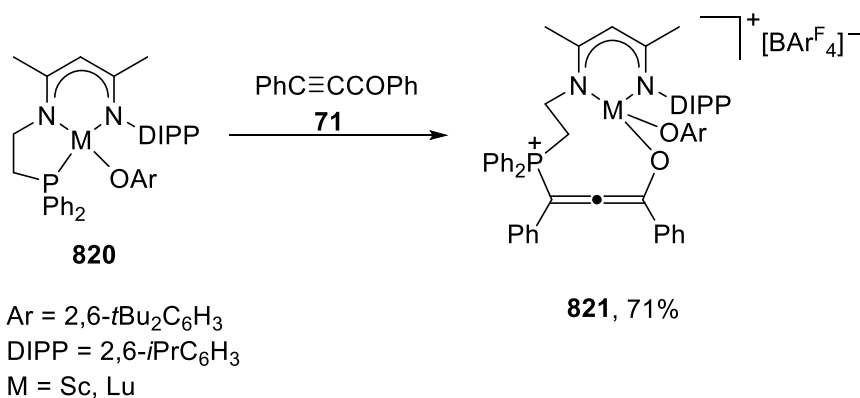

Figure 13. Ru-Complexes **818** and **819**.

Scheme 365. Isomerization of Ynone 71 in Complexes 821



Finally, when 1-phenyl-3-propyn-1-one (**71**) was subjected to Fischer's carbene complexes, the corresponding vinylidene metalpentacarbonyls (**822**) were isolated in low to moderate yields (Scheme 366).⁵⁶⁶

Scheme 366. Preparation of Metal Carbenes 822

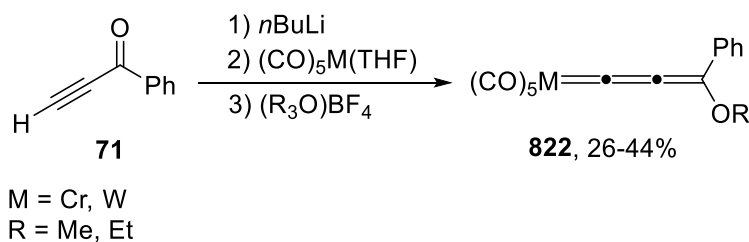

3.5.4. Other Processes. A series of ynones have proven to be efficient ligands for copper in the coupling between aryl iodides and terminal alkynes (**127**) to give compounds **823**, the most efficient being ynone **824** (Scheme 367). This transformation requires the use of an equimolecular amount the copper(I) salt.⁵⁶⁷

Scheme 367. Sonogashira Reaction of Aryl Iodides and Acetylenes 127 Catalyzed by Ynone 824

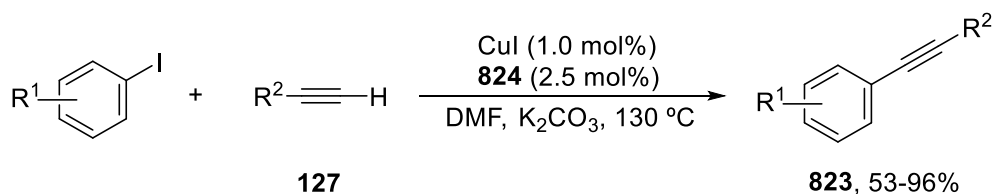

R¹ = H, 4-MeO, 4-Me, 4-O₂N, 4-Et, 4-MeCO, 4-EtO₂C, 4-F₃C, 4-F₃CO, 4-Br, 4-Cl,
2-MeO, 2-Me, 2-F₃C, 2-Cl, 3-I, 3-MeO, 3-Me, 3-F₃C, 1-naphthyl

R² = Ph, Me(CH₂)₅, 4-MeC₆H₄, 4-EtC₆H₄, 4-*n*BuC₆H₄, 4-MeOC₆H₄, 4-H₂NC₆H₄,
3-MeC₆H₄

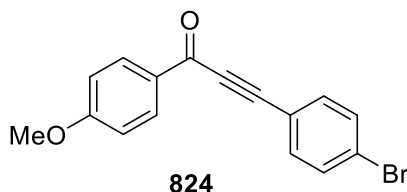

Yadav and co-workers reported on the reaction of electron-rich arenes with ynones (**71**) catalyzed by gallium(III) chloride, which gave the corresponding (*E*)-enones (**236**) in good yield as the only product (Scheme 368).⁵⁶⁸

Scheme 368. Preparation of Enones **236** by Reaction of Ynones **71** with Arenes

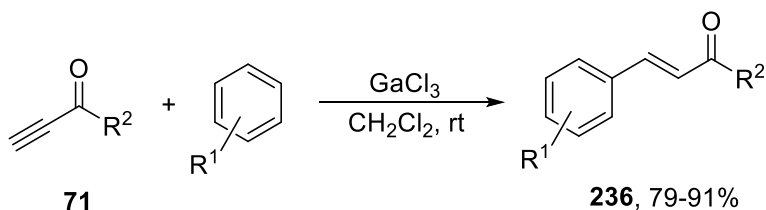

R¹ = 3,4-(MeO)₂, 3-Me-4-HO, 2-Me-4-HO, 4-HO, 2-Me-5-Br, 4-MeO

R² = Me, *n*C₅H₁₁

α,α -Dibromoketones (**224**, easily obtained from ethyl acetylene carboxylates; Scheme 99, Section 2.4.2) can be transformed into the corresponding silyl enol ethers (**825**) and 1-(1-alkynyl)-2,2-dibromovinyl acetates **826** in good yields (Scheme 369). Acetates **826** appeared to be excellent substrates for the synthesis of several tri(1-alkynyl)vinyl acetates **827** and some 1-(1-alkynyl)-2,2-diarylvinyl acetates **828** following standard methodologies (Scheme 369).²⁹³

Scheme 369. Preparation of Dibromoenynes Acetates **826** and Subsequent Palladium-Catalyzed Transformations

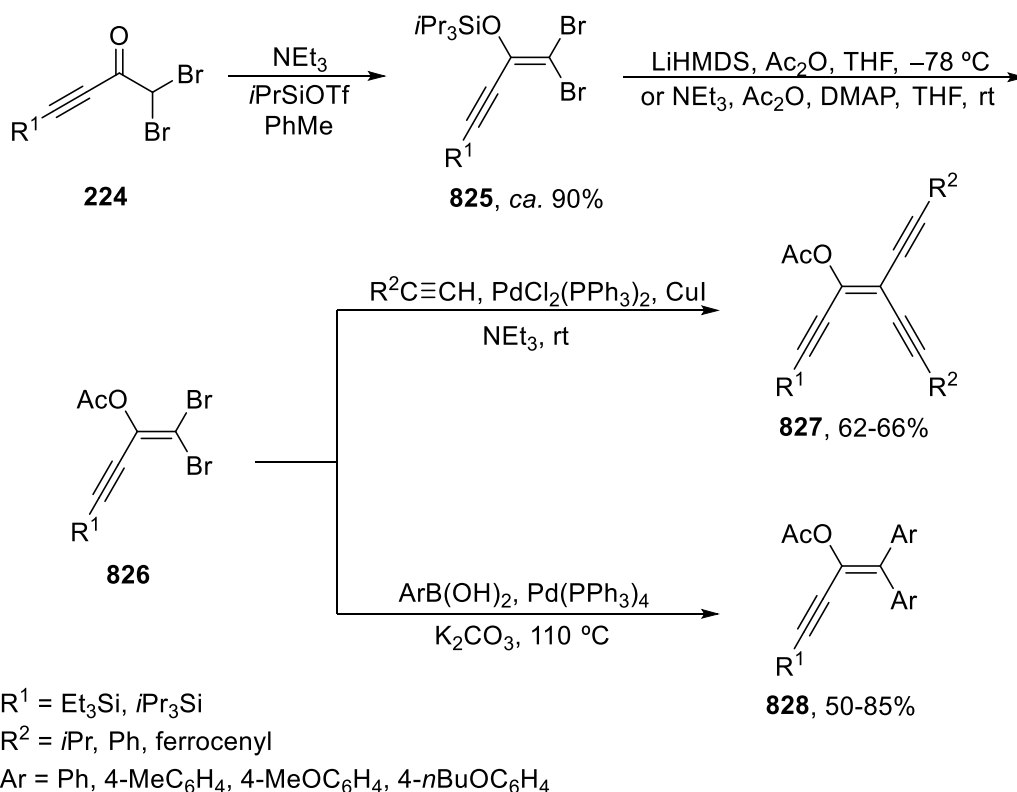

Another type of dihaloketones are α,β -derivatives **829/830**, which are prepared by addition of HalCl (Hal = Br, I) to ynones **71** in dichloromethane and isolated in a variable ratio depending on the reaction conditions used (Scheme 370).⁵⁶⁹ A mechanistic proposal involves intermediates **I-III**, of which the last is able to react with HalCl to yield products **829** and **830**.

Scheme 370. Transformation of Ynones **71** into Dihaloketones **829** and **830**

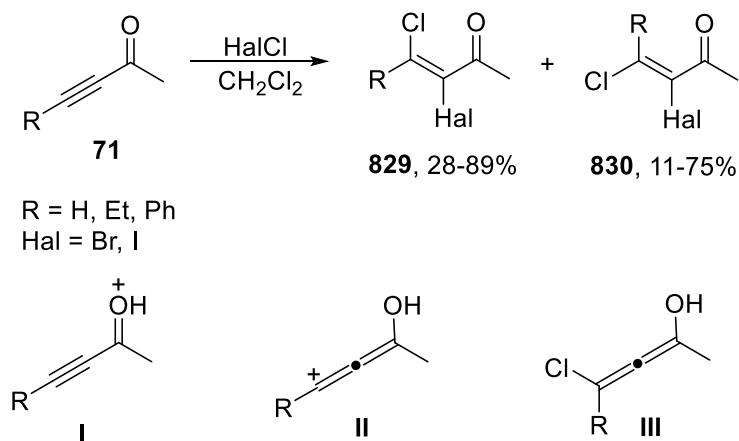

Acylation of ynones can take place at the oxygen or at the β -position. The first of the two options took place when ynone **831** was reacted with acetic anhydride in the presence of an amine and gave *Z/E* mixtures of conjugated enyne **832** (Scheme 371).¹⁰¹ The *Z/E* ratio depended on the reaction conditions. This enyne was then desilylated to yield the terminal alkyne **833**, which was converted into the diyne **834** (by reaction with the

iodoalkyne **835**) that was subsequently used in the total synthesis of peyssonenyne (Scheme 371).¹⁰¹

Scheme 371. Preparation of Endiyne **834** from Ynone **831**

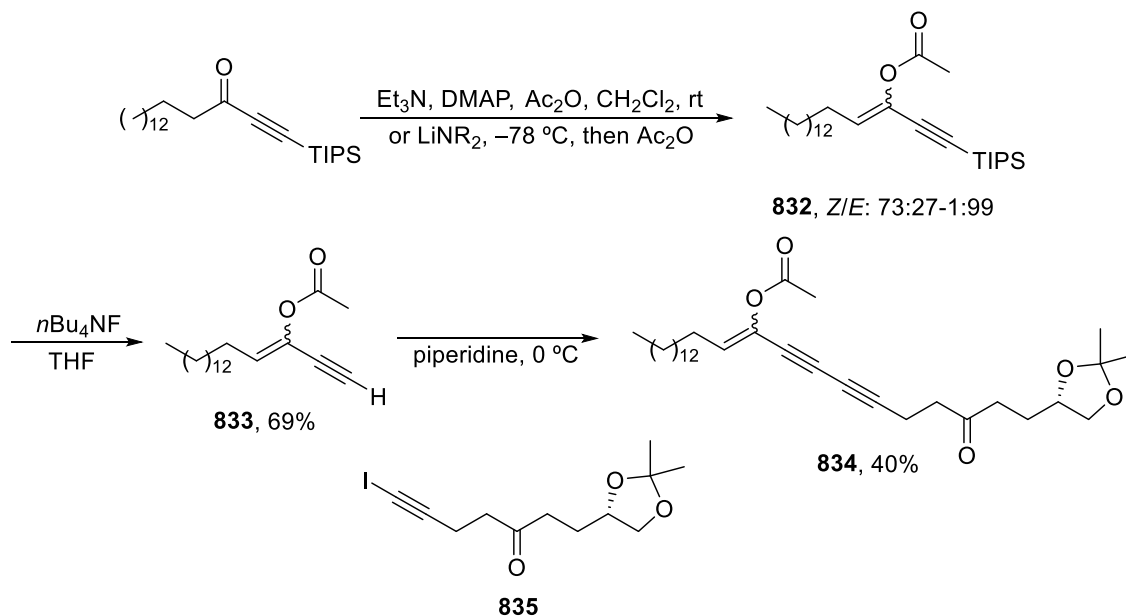

As commented in Section 3.1.2.2, the β -acylation of ynones was accomplished by a Pd-catalyzed reaction of ynones **71** with acylzirconocene complex **258**. The corresponding β -acylenones (**259**) were obtained in up to excellent yield with a predominance of the Z-isomer (Scheme 372).³¹⁷ A mechanistic proposal for the reaction, involving intermediates **I** [using Pd(II)] and **II** in the catalytic cycle, has been put forward.

Scheme 372. β -Acylation of Ynones **71** to give Enediones **259**

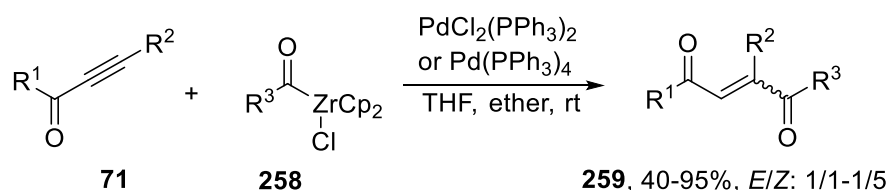

R¹ = Me, *t*Bu, Ph

R² = *n*Bu, *t*Bu, BnO(CH₂)₂, Ph

R³ = *n*C₈H₁₇, CyCH₂, Cy, *t*Bu(CH₂)₂

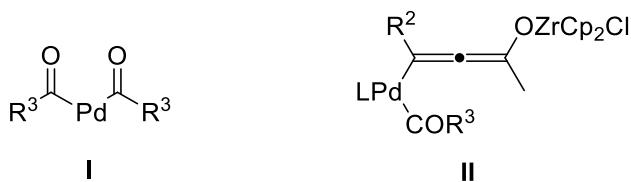

An interesting reaction, both from a mechanistic and synthetic point of view, is the decarbonylation of diyones (**48**). Dong and co-workers discovered that Rh(I) complexes are able to decarbonylate **48** and obtain diyne **836** in refluxing chlorobenzene in the

presence of diphosphine dppf (Scheme 373).^{570,571} Intermediates **I-III** can explain the course of the decarbonylation.

Scheme 373. Decarbonylation of Compounds **48** to give Diynes **836**

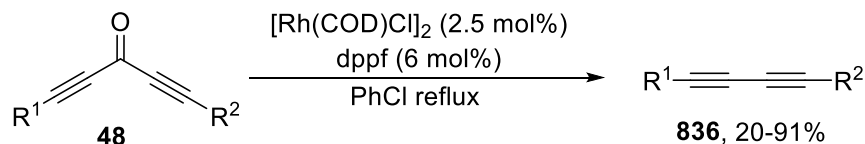

$\text{R}^1 = \text{R}^2 = \text{Ph}$, 4-MeC₆H₄, 4-MeOC₆H₄, 4-ClC₆H₄, 4-FC₆H₄, 1-naphthyl, 2,4,6-Me₃C₆H₂, 1-cyclohexenyl, Cy, PMBO(CH₂)₂

$\text{R}^1 = \text{Ph}$; $\text{R}^2 =$ 4-MeOC₆H₄, 2,4,6-Me₃C₆H₂, 1-cyclohexenyl, 4-ClC₆H₄, 2-naphthyl, PMBO(CH₂)₂, *N*-tosyl-3-indolyl

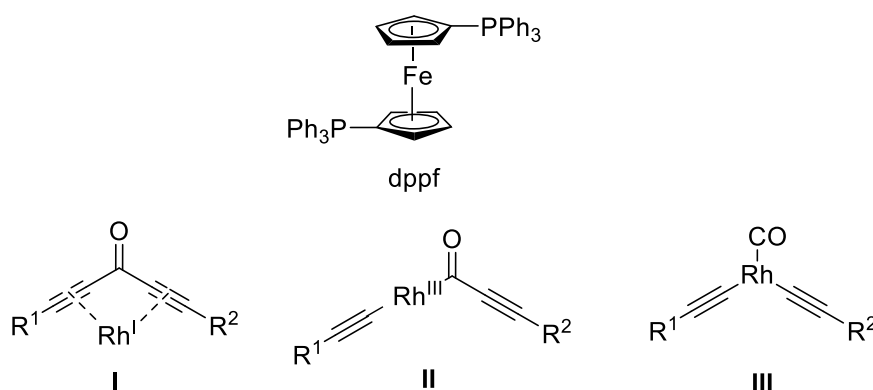

The Nicholas reaction of alkynes represents a protection of the triple bond and also an activation at the propargylic position. When protected ynones react with Co₂(CO)₆, the corresponding complexes **837** were easily produced, and these compounds reacted with different nucleophiles to give a range of γ -substituted products (**838**) in good yields (Scheme 374).⁵⁷² The final deprotection of **838** with (NH₄)₂Ce(NO₃)₆ (CAN) in acetone gave the corresponding ynones in >80% yield.

Scheme 374. Regio- and Diastereoselective Reaction of Complexes **837** with Nucleophiles

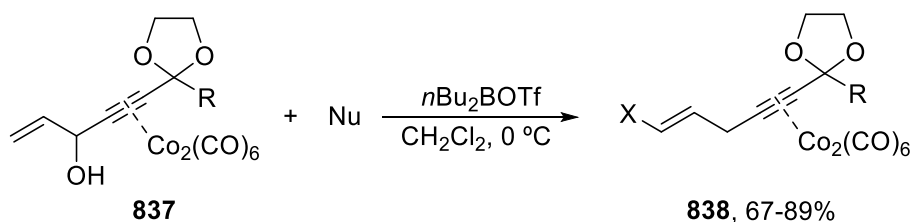

$\text{R} = t\text{Bu}$, $n\text{C}_6\text{H}_{13}$

$\text{Nu} = \text{MeOH}$, 1,3,5-(MeO)₃C₆H₃, CH₂=CHCH₂SiMe₃, thiophene, 1,3,5-Me₃C₆H₃, *N*-methylpyrrole

$\text{X} = \text{MeO}$, 2,4,6-(MeO)₃C₆H₂, CH₂=CHCH₂, 2-thienyl, 2,4,6-Me₃C₆H₂, *N*-methyl-2-pyrrolyl

The so-called P/B-frustrated Lewis pairs⁵⁷³ can be added to conjugated ynones in a 1,4-fashion. For instance, ynone **71** reacted with compound **839** [in situ prepared by reaction of $\text{Mes}_2\text{PCH}=\text{CH}_2$ with $\text{HB}(\text{C}_6\text{F}_5)_2$ in heptane] to yield the eight-membered zwitterionic heterocycles **840** (Scheme 375).⁵⁷⁴ It was assumed that the product was formed in a step-wise reaction that probably is initiated by conjugate P-addition to give allenic enolate **I**. Subsequent tautomerization to the exocyclic enolate may allow ring closure by oxygen-boron bond formation to afford the obtained product **840**.

Scheme 375. 1,4-Addition of Compound 839 to the Ynone 71

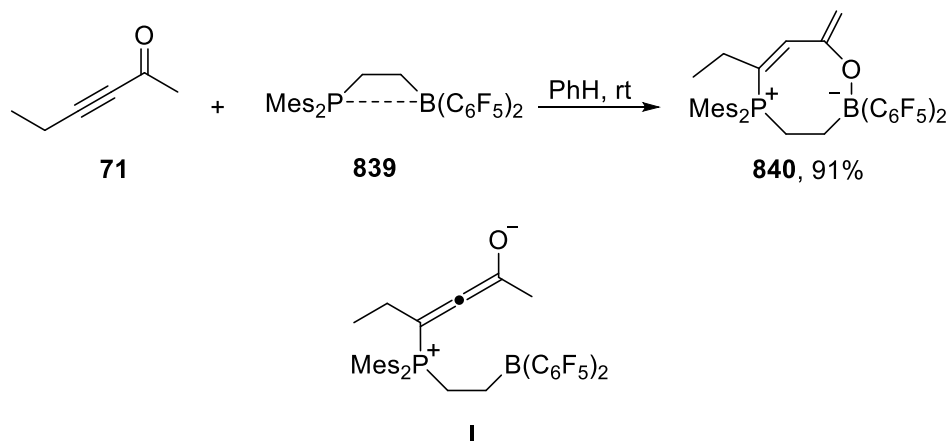

In conclusion, the aldol, Mannich and Michael reactions of ynones are very productive under both metal and organocatalysis. Concerning carbo- and heterocyclizations, either intra or intermolecular processes are reported being also metal or organocatalyzed. Isomerizations of ynones to dienones can be easily achieved by means of a phosphine. Finally, the 1,4-addition of a P/B frustrated Lewis pair to an ynone allows the formation of an eight-membered zwitterionic heterocycle.

4. Conclusions

The review documents that α,β -unsaturated acetylenic ketones are easy to prepare even on a large scale and undergo quite a few useful transformations in a predictable fashion. However, the scope of many of the reactions have not been thoroughly investigated, so easy access and rich chemistry should be a promising starting point for turning ynones into attractive reactants in organic synthesis.

Many methods are available for their preparation. The standard approach in the past was to oxidize propargylic alcohols, a transformation which can be achieved by a variety of reagents under conditions that vary from strongly acidic to basic. Due to the broad reactivity of most of these reagents, their scope was somewhat limited, and this triggered lots of efforts to develop new and selective methods that would expand the range of easily available functionalized, conjugated ynones. And this was indeed achieved. Acylation of alkynylmetal reagents represented some improvement; particularly the reactions with Weinreb and similar amides, but a considerable step forward did not come before the

catalytical capabilities exhibited by metal complexes and clusters gradually were uncovered. This knowledge led to the development of a good number of reactions that perform alkynylation of acid derivatives and carbonylation of terminal alkynes by metal catalysts, mainly containing Cu and Pd, with an expanded tolerance of functional groups in the reactants. Consequently, today synthetic methods are available for the synthesis of α,β -unsaturated ynones with significant structural variations in the substituents attached to both the β -carbon and the carbonyl.

From this review, it is clear that the electrophilicity and the polarization of the triple bond are two factors that influence the reactivity of conjugated ynones a lot. The ynone chemistry is therefore predominated by cycloaddition reactions and reactions with nucleophiles. The latter group of transformations consists of straightforward reactions at the carbonyl group (1,2 addition) and more complex reactions, initiated by 1,4 addition to the conjugated system (1,4-addition), and leading to allenolate formation (Michael reactions). Of these, the Michael reactions are the most attractive, not only because many simple addition products are useful in their own right, but also because secondary reactions may take place. Such reactions can materialize 1) if allenolate intermediates from ynones undergo intramolecular secondary reactions with an electrophilic moiety (e.g. an electron-deficient C=C bond or an electron-poor aryl group) properly located elsewhere in the molecule; and 2) if α,β -unsaturated enones formed in the first step suffer Michael addition because a nucleophile (e.g. a hydroxyl or an amino group) is available elsewhere in the molecule. This secondary reactivity has been utilized somewhat to synthesize nitrogen and oxygen heterocycles and prepare spiro compounds, but it is envisaged that incorporation of a variety of other reactive moieties can be a useful approach to target a range of other cyclic compounds as well.

The formation of many of the products obtained from conjugate additions to ynones is initiated by intramolecular nucleophilic attack of the triple bond, if necessary made possible by electrophilic activation by complexation with metals such as Ag(I), Au(III), Cu(I) and Pt(II). In some of these reactions chiral ligands have been added and resulted in enantioselective reactions with ee values that have been difficult to rationalize and worse to predict. However, the results reported so far can be regarded as a proof of concept, and it is therefore not unlikely that other combinations of cation(s), ligand(s) and substrate(s) will turn ynones into attractive synthons for introduction of chiral entities into complex molecules.

In addition, the review shows that relatively few studies of cycloadditions with conjugated ynones have been performed. A reason may be that quite a few of the cycloadducts reported are thermally unstable. However, the end product in several of these cases are aromatic compounds, and by introducing functionalized, synthetically useful substituents in key positions, ynones may turn out to be excellent starting materials for targeted synthesis of specific aromatic motifs for various purposes, for instance for use in medicinal chemistry.

As documented in the review, reactions between ynones and dinucleophiles, and between simple nucleophiles and ynones with a nucleophilic center well positioned to attack any enone formed in the first reaction, are excellent approaches to synthesize a variety of heterocycles that might be of medicinal significance. However, again the substituent variation has been rather limited, making the scope of these reaction an obvious target for research.

Few reports have been published on the selective reduction of the triple bond of ynones. However, the chemoselective addition to the carbonyl group has been well documented even in an asymmetric fashion giving enantiomerically enriched propargylic alcohols. As nucleophiles, carbon- and hetero-nucleophiles have been successfully used, as well as different types of hydrides or by hydrogen transfer.

Finally, in the last part of this review article other reactions are included concerning aldol processes, intra- and inter-molecular cyclizations and isomerizations to yield conjugated dienones.

Throughout this paper special attention is paid to the applications of the different methodologies involving conjugated ynones to the total synthesis of several natural products. With an expansion of the scope of (some of) the reactions ynones undergo, it is likely that α,β -unsaturated alkynones will become more important in the synthesis of complex molecules.

AUTHOR INFORMATION

Corresponding Author

Phone: +4755583450 E-mail: leiv.sydnes@uib.no

ORCID[®]

Carmen Nájera: 0000-0003-0063-5527

Leiv K. Sydnes: 0000-0001-7859-277X

Miguel Yus: 0000-0003-1088-6944

Notes

The authors declare no competing financial interest.

Biographies

Carmen Nájera was born in Nájera (La Rioja) in 1951 and graduated from the University of Zaragoza in 1973, obtaining her doctorate in chemistry from the University of Oviedo

in 1979. She spent postdoctoral stays at the ETH Zurich), the Dyson Perrins Laboratory (Oxford), Harvard University, and Uppsala University. She became Associate Professor in 1985 at the University of Oviedo and Full Professor in 1993 at the University of Alicante. She is coauthor of more than 400 papers (h 68), 6 papers and 30 book chapters and has supervised more than 45 Ph.D. students. She has been awarded with the 2006 Organic Chemistry Prize from the Spanish Royal Chemical Society, the 2006 Rosalind Franklin International Lectureship from the English Royal Society, the SSCF 2010 French-Spanish Prize from the Société Chimique de France, the IUPAC 2015 Distinguished Women in Chemistry or Chemical Engineering Award, the 2018 Serratosa Lectureship. In 2012 was named full Member of the Spanish Royal Academy of Science and was as Active Member of the European Academy of Sciences and Arts. Professor Nájera has been in the Advisory Board of several international journals, among others *Tetrahedron*, *Tetrahedron Letters*, *Tetrahedron: Asymmetry*, *Synthesis*, *European Journal of Organic Chemistry*, *Chemistry Letters* and *ChemCatChem* and in 2016-2017 was named ChemPubSoc Europe Fellow. Professor Nájera has been founder and Manager Director of the chemical company MEDALCHEMY S.L. for the development of APIs.

Leiv K. Sydnes was born in Haugesund (Norway) in 1948 and received his education at University of Oslo, Norway, where he obtained his Cand. real. degree (1974) and the Doctor of Philosophy degree (1978), both in organic chemistry. He then worked with photochemistry as a Postdoctoral Fellow at the University of Western Ontario (Canada) under the guidance of Professor Paul de Mayo. In 1980 he was appointed Associate Professor at University of Tromsø (Norway) where he was promoted to Full Professor in 1987. In 1993 he became Full Professor at University of Bergen (Norway), where he has been Professor Emeritus since August 2018. Over the years Professor Sydnes has been visiting professor at a number of institutions including Iowa State University, Australian National University, University of New South Wales, Victoria University, Universität Wien, La Laguna University, and University of Alicante. His research has focused on organic synthesis with emphasis on development of synthetic methodology based on cyclopropanes and photochemistry. Photochemistry has also been central in his participation in integrated environmental research related to degradation of natural and anthropogenic organic compounds in the marine environment. This has resulted in more than 150 publications (and six patents) and 15 contributions to books, most extensively to volumes of *Houben-Weyl Methoden der Organischen Chemie*. Sydnes has for decades been referee for a number of chemical journals and been actively involved as a conference organizer in Norway and abroad. He has also been heavily engaged for years in IUPAC, on the Board and as Vice President, President and Past President 2002-2007, and worked with several international organizations including UNESCO, ICSU, and OPCW. Sydnes has a considerable body of outreach activities to his merit, including public lectures, interactive experimentation for school children, and making TV programs for the general public. He has received international awards and is an elected member of several academies.

Miguel Yus was born in Zaragoza (Spain) in 1947 and received his BSc(1969), MSc (1971) and Ph.D. (1973) degrees from the University of Zaragoza. After spending two years as a Postdoctoral Fellow at the Max Planck Institut für Kohlenforschung in Mülheim a. d. Ruhr, he returned to Spain to the University of Oviedo where he became Associate Professor in 1977 and promoted to Full Professor in 1987. In 1988 he moved to a chair in Organic Chemistry at the University of Alicante. Professor Yus has been visiting professor at different institutions and universities, among them ETH-Zentrum, Oxford, Harvard, Uppsala, Marseille, Tucson, Okayama, Paris, Strasbourg, Bolonia, Sassari, Tokyo and Kyoto. He is coauthor of more than 600 papers, (h 73) and 5 patents, and he has supervised more than 60 Doctoral Theses. He has delivered more than 200 lectures, most of them abroad. Among other, he has received the Spanish-French Prize (1999), the Japan Society for the Promotion of Science (Okayama 2000, Kyoto 2007), the Stiefvater Memorial Lectureship Award (Lincoln 2001), the Nagase Science and Technology Foundation Fellowship (Kyoto 2003), the Cellchem Lectureship (Sheffield 2005), the Singenta Lectureship (Base 2007), the Fundeun-Iberdrola Prize (Alicante 2007), the Serratosa Lectureship (Barcelona 2010), the Conferencia Lourenço-Madinaveitia (Lisboa 2012), the Medalla Félix Serratosa from the RSEQ (Madrid 2012), being also named Active Academician from the European Academy of Sciences and Arts (Salzburg 2012) and Academic Member of the Athens Institute for Education and Research. Professor Yus has been on the Advisory Board of 30 international journals, among others *Tetrahedron*, *Tetrahedron Letters*, *European Journal of Organic Chemistry*, *Chemistry Letters*, *The Chemical Record*, *Current Organic Chemistry*, *Current and Chemical Biology*, being also Editor in Chief of *Letters in Organic Chemistry* and *Open Chemistry*, as well as Regional Editor of the *World Journal of Chemistry*. Professor Yus founded the new Chemical Company MEDALCHEMY S.L. for the development of APIs.

ACKNOWLEDGEMENTS

We thank to the Spanish Ministerio de Economía, Industria y Competitividad, Agencia Estatal de Investigación (AEI) and Fondo Europeo de Desarrollo Regional (FEDER, EU) (projects CTQ2016-76782-P, CTQ2016-81797-REDC, and CTQ2017-85093-P), the Generalitat Valenciana (PROMETEOII/ 2014/017) and the University of Alicante for financial support. Likewise, financial support from the Research Council of Norway, the University of Bergen, and the Meltzer Research Fund is highly appreciated.

ABBREVIATIONS

Ac: acetyl

acac: acetylacetonate

AAC: azide-alkyne cycloaddition

Ad: 1-adamantyl

AH-1763: antiherpetic anthrapyran antibiotic

AIAC: azomethine ylide-imine cycloaddition

AIBN: azobis(isobutyronitrile)

All: allyl
APTES: (3-aminopropyl)triethoxysilane
Ar: aryl
Ar^F: pentafluorophenyl
ASM: (3-aminopropyl)trimethoxysilane
atm: atmosphere
B: base
BBN: borabicyclo[3.3.1]nonane
BBP: 1,2-bis(diphenylphosphono)benzene
BHT: 2,6-di(*tert*-butyl)-4-methylphenol
BINOL: 1,1'-bi-2-naphthol
BI-OAc: benziodoxole acetate
BIPy: bipyridine
bmim: 1-butyl-3-methylimidazolium
Bn: benzyl
Boc: *tert*-butoxycarbonyl
BOR: Bestman–Ohira reagent (dimethyl 1-diazo-2-oxopropyl phosphonate)
BPin: pinacolatoboryl
BPO: benzoyl peroxide
BPS: *tert*-butyldiphenylsilyl
bpy: 2,2'-bipyridine
Bz: benzoyl
ca.: *circa*
CAN: cerium ammonium nitrate
cat.: catalyst
CBS: Corey-Bakshi-Shibata
Cbz: benzyloxycarbonyl
COD: 1,5-cyclooctadiene
Cp*: pentamethylcyclopentadienyl
CPA: chiral phosphoric acid
CSA: camphorsulfonic acid
Cy: cyclohexyl
DABCO: 1,4-diazabicyclo[2.2.2]octane
dba: dibenzylideneacetone
DBU: 1,8-diazabicyclo[5.4.0]undec-7-ene
DCE: 1,2-dichloroethane
DCM: dichloromethane
DDQ: 2,3-dichloro-5,6-dicyano-1,4-quinone
dF(CF₃)PPy: 2-(2,4-difluorophenyl)-5-(trifluoromethyl)pyridine
DFT: density functional theory
[DHQ]₂PHAL: hydroquinine 1,4-phthalazinediyl diether
DIOP: 4,5-bis[(diphenylphosphino)methyl]-2,2-dimethyl-1,3-dioxolane
DIPEA: diisopropylethylamine
DIPP: 2,6-diisopropylphenyl

DMA: *N,N*-dimethylacetamide
DMF: dimethylformamide
DMI: 1,3-dimethyl-2-imidazolidine
DMP: Dess–Martin periodinane
DMPA: 4-dimethylaminopyridine
DMPP: dimethylphenoxaphosphino
DMSO: dimethylsulfoxide
DNA: deoxyribonucleic acid
dppb: 1,4-bis(diphenylphosphino)butane
dppe: 1,2-bis(diphenylphosphino)ethane
dppf: 1,1'-ferrocenediyl-bis-(diphenylphosphine)
dppp: diphenylpropylendiphosphine
dtbbPy: 4,4'-di-*tert*-butyl-2,2'-bipyridine
DTBM-SegPhos: 5,5'-bis[di(3,5-di-*tert*-butyl-4-methoxyphenyl)phosphino]-4,4'-bi-1,3-benzodioxole
DTBP: 2,6-di-(*tert*-butyl)pyridine
DVB: divinylbenzene
EAA: ethyl acetoacetate
EBX: ethylbenziodoxolane(s)
EE: ethoxyethyl
EPA: eicosapentaenoic acid
eq: equivalent(s)
FBW: Fritsch-Buttenburg-Wiechell
FOXAP: ferrocenyl oxazolinyldiphosphine
Hept: heptyl
Hex: hexyl
hfac: hexafluoroacetylacetone
HFIP: hexafluoroisopropanol
HMDS: hexamethyldisilazide
IBX: 2-iodoxybenzoic acid
IL: ionic liquid
IRA: ion exchange resin
JJ-PP: polymeric phosphine
JohnPhos: (2-biphenyl)di-*tert*-butylphosphine
L: ligand
LA: Lewis acid
LDA: lithium diisopropylamide
LED: light-emitting diode
MAA: methyl acetoacetate
Mbs: 4-methoxybenzenesulfonyl
MCM-41: metal modified mesoporous silicate
Mes: mesityl
MOE: methoxyethyl
MOF: metalorganic framework

MP: mesoporous
MPM: methoxybenzyl
MS: molecular sieves
MW: microwaves
MWNT: multiwalled carbon nanotubes fluoride
NBS: *N*-bromosuccinimide
NCS: *N*-chlorosuccinimide
nd: not determined/not given
Neophyl: 2,2-dimethyl-2-phenylethyl
NIS: *N*-iodosuccinimide
NfF: nonafluorobutanesulfonyl
NHC: *N*-heterocyclic carbene
NMP: *N*-methylpyrrolidinone
Non: nonyl
NP: nanoparticle
NP25 302: antileukemic agent
Ns: 4-nitrobenzenesulfonyl
NS: nanosized
Nu: nucleophile
PA-Ph: 1,3,5,7-tetramethyl-2,4,8-trioxa-6-phenyl-6-phosphadamantane
PCC: pyridinium chlorochromate
PDC: pyridinium dichromate
PDDA: photo-dehydro-Diels–Alder
PDIPA: pinacolate diisopropanolaminato diboron
PEG: polyethyleneglycol
Pent: pentyl
PG: protecting group, prostaglandin
Piv: *tert*-butylcarbonyl
PMB: 4-methoxybenzyl
PMHS: polymethylhydrosilane
PMP: 4-methoxyphenyl
PPS: poly-1,4-phenylene sulfide
ProPhenol: 2,6-bis[2-(hydroxydiphenyl)-1-pyrrolidinylmethyl]-4-methylphenol
PS: polystyrene, mesoporous tin silicate
psi: pounds per square inch
PS-TPP: polymeric phosphine
PTSA, *p*-TSA: *p*-toluenesulfonic acid
Py: pyridyl
PyH: pyridine
rt: room temperature
SBA: mesoporous silica
Sc: salicylaldehyde
SDS: sodium dodecyl sulphate
Selectfluor: 1-chloromethyl-4-fluoro-1,4-diazoniabicyclo[2.2.2]octane

SPhos: bistetrabluoroboratedicyclohexyl[2-(2,6-dimethoxyphenyl)]phosphine
 SS4305-e': anthrapyran metabolite
 SWNT: single-walled carbon nanotubes
 TarB: 2 phenyl-1,3,2-dioxaborolane-4*R*,5*R*-dicarboxylic acid
 TASF: tris(dimethylamino)sulfonium difluorotrimethylsilicate
 TBAF: tetra-*n*-butylammonium fluoride
 TBDPS: *tert*-butyldiphenylsilyl
 TBHP: *tert*-butyl hydroperoxide
 TBS, TBDMS: *tert*-butyldimethylsilyl
 TCT: 2,4,6-trichloro-1,3,5-triazine
 TEATFB: tetraethylammonium tetrafluoroborate
 TES: triethylsilyl
 Tf: trifluoromethylsulfonyl
 TFA: trifluoroacetate, trifluoroacetic acid
 TFAA: trifluoroacetic anhydride
 TFE: trifluoroethanol
 TFP: tri(2-furyl)phosphine
 THF: tetrahydrofuran
 THP: tetrahydropyranyl
 TIPS: triisopropylsilyl
 TMEDA: tetramethyl ethylenediamine
 TMHD: bis(2,2,6,6)-tetramethyl-3,5-heptadioate
 TMS: trimethylsilyl
 Tol: tolyl (4-methylphenyl)
 Tp: hydrotris(pyrazolyl)borate
 TPE: tetraphenylethylene
 TPGS-750-M: D- α -tocopherol polyethyleneglycol
 TPS: triphenylsilyl
 Tr: triphenylmethyl
 TRPTC: thermoregulated liquid/liquid catalytic
 Ts: 4-methylphenylsulfonyl
 Tz; 1,2,3-triazol-5-ylidene
 TZC: Tomita–Zipper cyclization
 W: watio(s)
 XantPhos: 4,5-bis(diphenylphosphino)-9,9-dimethylxanthene
 XPhos: dicyclohexyl[2-(2,4,6-triisopropylphenyl)]phosphine

REFERENCES

- (1) Whittaker, R. E.; Dermenci, A.; Dong, G. Synthesis of Ynones and Recent Application in Transition-Metal-Catalyzed Reactions. *Synthesis* **2016**, *48*, 161–183.
- (2) Listunov, D.; Maraval, V.; Chauvin, R.; Génisson, Y. Chiral Alkynylcarbinols from Marine Sponges: Asymmetric Synthesis and Biological Relevance. *Nat. Prod. Rep.* **2015**, *32*, 49–75.
- (3) Nelson, A. Product Class 7: Ynones. *Science of Synthesis* **2005**, *26*, 971–988.

- (4) Rulev, A. Y.; Romanov, A. R. Unsaturated Polyfluoroalkyl Ketones in the Synthesis of Nitrogen-Bearing Heterocycles. *RSC Adv.* **2016**, *6*, 1984–1998.
- (5) Salvio, R.; Moliterno, M.; Bella, M. Alkynes in Organocatalysis. *Asian J. Org. Chem.* **2014**, *3*, 340–351.
- (6) Fraile, A.; Parra, A.; Tortosa, M.; Alemán, J. Organocatalytic Transformations of Alkynals, Alkynones, Propiolates, and Related Electron-Deficient Alkynes. *Tetrahedron* **2014**, *70*, 9145–9173.
- (7) Abbiati, G.; Arcadi, A.; Marinelli, F.; Rossi, E. Sequential Addition and Cyclization Processes of α,β -Ynones and α,β -Ynoates Containing Proximate Nucleophiles. *Synthesis* **2014**, *46*, 687–721.
- (8) Fustero, S.; Sánchez-Roselló, M.; Barrio, P.; Simón-Fuentes, A. From 2000 to Mid-2010: A Fruitful Decade for the Synthesis of Pyrazoles. *Chem. Rev.* **2011**, *111*, 6984–7034.
- (9) Arai, T.; Ikematsu, Y.; Suemitsu, Y. Nickel-Catalyzed Multicomponent Coupling Reactions Using Ynones. *Pure Appl. Chem.* **2010**, *82*, 1485–1490.
- (10) Müller, T. J. J. Palladium-Copper Catalyzed Alkyne Activation as an Entry to Multicomponent Synthesis of Heterocycles. *Top. Heterocycl. Chem.* **2010**, *25*, 25–94.
- (11) Yus, M.; Nájera, C. Synthesis by Reduction of 1,2-Diketones and α -Diazoketones, α,α -Dihetero, and α -Hetero-Substituted Ketones, Enones and Ynones. *Science of Synthesis* **2005**, *26*, 153-241.
- (12) Isele, G. L.; Schreib, K. 1-Amino-2,6-hexacosamethylen-4-pyridon, Ein Ausgangsverbindung für Eine Mögliche Catenan-Synthese. *Chem. Ber.* **1975**, *108*, 2312–2319.
- (13) Cornelius, L. A. M.; Bone, R. G. A.; Hastings, R. H.; Deardorff, M. A.; Scharlach, R. A.; Hauptmann, B. E.; Stankovic, C. S.; Pinnick, H. W. Synthesis of 2-Acetylbicyclo[2.2.1]hept-2-ene. *J. Org. Chem.* **1993**, *58*, 3188–3190 (Corrigendum: *J. Org. Chem.* **1993**, *50*, 4744).
- (14) Yalovleva, E. A.; Ivanchikova, I. D.; Shvartsberg, M. S. Synthesis of Substituted Benzo[*g*]indole-6,9-diones and Benzo[*h*]quinoline-7,10-naphthoquinones. *Russ. Chem. Bull., Int. Ed.* **2005**, *54*, 421–427.
- (15) Sardina, F. J.; Mouriño, A.; Castedo, L. Studies on the Synthesis of Side-Chain Hydroxylated Metabolites of Vitamin D2. Stereocontrolled Synthesis of 25-Hydroxyvitamin D2. *J. Org. Chem.* **1986**, *51*, 1264–1269.
- (16) Axelrod, A.; Eliassen, A. M.; Chin, M. R.; Zlotkowski, K.; Siegel, D. Synthesis of Xanthofulvin and Vinaxanthone, Natural Products Enabling Spinal Cord Regeneration. *Angew. Chem., Int. Ed.* **2013**, *52*, 3421–3424.
- (17) Yoshimatsu, M.; Oh-Ishi, K.; Tanabe, G.; Muraoka, O. The First Isolation and Characterization of Sulfonylbuta-1,3-diyne. *J. Chem. Soc., Perkin Trans. 1* **2002**, 1413–1416.
- (18) Menon, R. S.; Banwell, M. G. Total Synthesis of the Furanosquiterpenes Crassifolone and Dihydrocrassifolone via an Au(I)-Catalyzed Intramolecular Michael Addition Reaction. *Org. Biomol. Chem.* **2010**, *8*, 5483–5485.

- (19) Druais, V.; Meyer, C.; Cossy, J. Catalytic Diastereoselective Reduction of α,β -Aziridinyl Ynones. *Org. Lett.* **2012**, *14*, 516–519.
- (20) Cao, Z.; Zhu, H.; Meng, X.; Guan, J.; Zhang, Q.; Tian, L.; Sun, X.; Chen, G.; You, J. Metal-Free Reaction of *ortho*-Carbonylated Alkynyl-Substituted Arylaldehydes with Common Amines: Selective Access to Functionalized Isoindoline and Indeamine Derivatives. *Chem. – Eur. J.* **2016**, *22*, 16979–16985.
- (21) Bao, W. L.; Wang, Q.; Zheng, Y. F. A Facile and Efficient Oxidation of α,β -Unsaturated Alcohols with Manganese Dioxide in Ionic Liquids under Mild Conditions. *Chin. Chem. Lett.* **2004**, *15*, 1029–1032.
- (22) Okamura, W. H.; Peter, R.; Roischl, W. Allenyldiene Electrocyclization: A Stereospecific Tandem Center-Axis-Center Chirality Transfer: Synthesis of Drimatrienes and Related *trans*-Decalins. *J. Am. Chem. Soc.* **1985**, *107*, 1034–1041.
- (23) Aiguade, J.; Hao, J.; Forsyth, C. J. Synthesis of a 2,9-Dioxabicyclo[3.1.1]nonane via Double Intramolecular Hetero-Michael Addition: Entry to the f-g Ring System of the Azaspiracids. *Org. Lett.* **2001**, *3*, 979–982.
- (24) Forsyth, C. J.; Xu, J.; Nguyen, S. T.; Samdal, I. A.; Briggs, L. R.; Rundberget, T.; Sandvik, M.; Miles, C. O. Antibodies with Broad Specificity to Azaspiracids by Use of Synthetic Haptens. *J. Am. Chem. Soc.* **2006**, *128*, 15114–15116.
- (25) Marshall, J. A.; Eidam, P.; Eidam, H. S. (*R*)- and (*S*)-4-TIPS-3-butyn-2-ol. Useful Precursor of Chiral Allenylzinc and Indium Reagents. *J. Org. Chem.* **2006**, *71*, 4840–4844.
- (26) Xing, Y.; O'Doherty, G. A. De Novo Asymmetric Synthesis of Cladospolide B-D: Structural Reassignment of Cladospolide D via the Synthesis of its Enantiomer. *Org. Lett.* **2009**, *11*, 1107–1110.
- (27) Zhao, T.; Xu, B. Palladium-Catalyzed Tandem Amination Reaction for the Synthesis of 4-Quinolones. *Org. Lett.* **2010**, *12*, 212–215.
- (28) Kirkham, J. D.; Edeson, S. J.; Stokes, S.; Harrity, J. P. A. Synthesis of Ynone Trifluoroborates Toward Functionalized Pyrazoles. *Org. Lett.* **2012**, *14*, 5354–5357.
- (29) Kraft, P.; Ahlin, J. S. E.; Buchel, M.; Sutter, P. On the Crossroad of Dienone Musks and Cassyrane: Synthesis and Olfactory Properties of New High-Impact Orris Odorants. *Synthesis* **2012**, *44*, 2985–2998.
- (30) Rode, N. D.; Arcadi, A.; Chiarini, M.; Marinelli, F. An Improved Environmentally Friendly Approach to 4-Nitro-, 4-Sulfonyl-, and 4-Aminoquinolines and 4-Quinolones through Conjugate Addition of Nucleophiles to β -(2-Aminophenyl)- α,β -ynones. *Synthesis* **2017**, *49*, 2501–2512.
- (31) Boger, D. L.; Ichikawa, S.; Jiang, H. Total Synthesis of the Rubrolone Aglycon. *J. Am. Chem. Soc.* **2000**, *122*, 12169–12173.
- (32) Gardiner, J. M.; Giles, P. E.; Martín, M. L. M. An Approach towards C12 Oxo Analogues of the side Chain of Pumiliotoxin B/Allopumiliotoxin 339 A and B. *Tetrahedron Lett.* **2002**, *43*, 5415–5418.
- (33) Shapland, P. D. P.; Thomas, E. J. Synthesis of Precursors of Phomactins using [2,3]-Wittig Rearrangements. *Tetrahedron* **2009**, *65*, 4201–4211.

- (34) Castillo-Contreras, E. B.; Dake, G. R. DMAP Promoted Tandem Addition Reactions Forming Substituted Tetrahydroxanthenes. *Org. Lett.* **2014**, *16*, 1642–1645.
- (35) García-Dominguez, P.; Lepore, I.; Erb, C.; Gronemeyer, H.; Altuca, L.; Álvarez, R.; de Lera, A. R.; Total Synthesis of the Proposed Structures of the DNA Methyl Transferase Inhibitors Peyssonenyne and Structural Revision of Peyssonenyne B. *Org. Biomol. Chem.* **2011**, *9*, 6979–6987.
- (36) Nicola, T.; Vieser, R.; Eberbach, W. Anionic Cyclizations of Pentynones and Hexynones: Access to Furan and Pyran Derivatives. *Eur. J. Org. Chem.* **2000**, 527–538.
- (37) De Luca, L.; Giacomelli, G.; Porcheddu, A. A Mild and Efficient Alternative to the Classical Swern Oxidation. *J. Org. Chem.* **2001**, *66*, 7907–7909.
- (38) Parikh, J. R.; Doering, W. V. E. Sulfur Trioxide in the Oxidation of Alcohols by Dimethyl Sulfoxide. *J. Am. Chem. Soc.* **1967**, *89*, 5505–5507.
- (39) Nonaka, H.; Maeda, N.; Kobayashi, Y. Improved Synthesis of the Polyhydroxylated Central Part of Phoslactomycin B. *Tetrahedron Lett.* **2007**, *48*, 5601–5604.
- (40) Wu, H.-H.; Hsu, S.-C.; Hsu, F.-L.; Uang, B.-J. Asymmetric Synthesis of (–)-Pterosin N from a Chiral 1,3-Dioxolanone. *Eur. J. Org. Chem.* **2014**, 4351–4355.
- (41) Meger, S. D.; Schreiber, S. L. Acceleration of the Dess-Martin Oxidation in Water. *J. Org. Chem.* **1994**, *59*, 7549–7552.
- (42) Ghosh, A. K.; Wang, Y. Total Synthesis of (–)-Laulimalide. *J. Am. Chem. Soc.* **2000**, *122*, 11027–11028.
- (43) Wender, P. A.; Bi, F. C.; Brodney, M. A.; Gosselin, F. Asymmetric Synthesis of the Tricyclic Core of NGF-Inducing Cyathane Diterpenes via a Transition-Metal-Catalyzed [5+2] Cycloaddition. *Org. Lett.* **2001**, *3*, 2105–2108.
- (44) Quesnelle, C. A.; Grill, P.; Dodier, M.; St Laurent, D.; Serrano-Wu, M.; Marinier, A.; Martel, A.; Mazzucco, C. E.; Stickle, T. M.; Barret, J. F.; Vyas, D. M.; Balasubramanian, B. N. Sordaricin Antifungal Agents. *Bioorg. Med. Chem. Lett.* **2003**, *13*, 519–524.
- (45) Gaunt, M. J.; Sneddon, H. F.; Hewitt, P. R.; Orsini, P.; Hook, D. F.; Ley, S. V. Development of β -Keto 1,3-Dithianes as α,β -Versatile Intermediates for Organic Synthesis. *Org. Biomol. Chem.* **2003**, *1*, 15–16.
- (46) Gaunt, M. J.; Hook, D. F.; Tanner, H. R.; Ley, S. V. A Practical and Efficient Synthesis of the C16-C28 Spiroketal Fragment (CD) of Spongistatins. *Org. Lett.* **2003**, *5*, 4815–4818.
- (47) Gaunt, M. J.; Jessiman, A. S.; Orsini, P.; Tanner, H. R.; Hook, D. F.; Ley, S. V. Synthesis of the C1-C28 ABCD Unit of Spongistatin 1. *Org. Lett.* **2003**, *5*, 4819–4822.
- (48) Sneddon, H. F.; Gaunt, M. J.; Ley, S. V. Addition of Dithiols to Bis-Ynones: Development of a Versatile Platform for the Synthesis of Polyketide Natural Products. *Org. Lett.* **2003**, *5*, 1147–1150.
- (49) Tello-Aburto, R.; Ochoa-Teran, A.; Olivo, H. F. Model Studies on the Ring Construction of the Auriside Macrolactone. *Tetrahedron Lett.* **2006**, *47*, 5915–5917.
- (50) Tello-Aburto, R.; Olivo, H. F. A Formal Synthesis of the Auriside Aglycon. *Org. Lett.* **2008**, *10*, 2191–2194.

- (51) Tietze, L. F.; Gericke, K. M.; Singidi, R. R. Enantioselective Total Synthesis and Structure Determination of the Antiherpetic Anthrapyran Antibiotic AH-1763IIa. *Angew. Chem., Int. Ed.* **2006**, *45*, 6990–6993.
- (52) Tietze, L. F.; Singidi, R. R.; Gericke, K. M. First Enantioselective Total Synthesis and Structure Determination of the Anthrapyran Metabolite γ -Indomycinone. *Org. Lett.* **2006**, *8*, 5873–5876.
- (53) Tietze, L. F.; Gericke, K. M.; Singidi, R. P.; Schubert, I. Novel Strategies for the Synthesis of Anthrapyran Antibiotics: Discovery of a New Antitumor Agent and Total Synthesis of (*S*)-Epicufolin. *Org. Biomol. Chem.* **2007**, *5*, 1191–1200.
- (54) Rixon, J. E.; Abraham, J. R.; Egoshi, Y.; Skelton, B. W.; Young, K.; Gilbert, J.; Sakoff, J. A.; Gericke, K. M.; McCluskey, A.; Stewart, S. G. The Synthesis and Biological Activity of Novel Anthracenone-Pyranones and Anthracenone-Furans. *Bioorg. Med. Chem.* **2015**, *23*, 3552–3565.
- (55) Pattenden, G.; Stoker, D. A.; Thomson, N. M. Cascade Radical-Mediated Cyclizations with Conjugates Ynone Electrophores. An Approach to the Synthesis of Steroids and other Novel Ring-Fused Polycyclic Carbocycles. *Org. Biomol. Chem.* **2007**, *5*, 1776–1778.
- (56) Jung, Y. C.; Yoon, C. H.; Turos, E.; Yon, E. T.; Yoo, K. S.; Jung, K. W. Total Synthesis of (-)- α -Kainic Acid and (+)- α -Allokainic Acid via Stereoselective C-H Insertion and Efficient 3,4-Stereocontrol. *J. Org. Chem.* **2007**, *72*, 10114–10122.
- (57) Trygstad, T. M.; Pang, Y.; Forsyth, C. J. Versatile Synthesis of the C3-C14 Domain of 7-Deoxyokadaic Acid. *J. Org. Chem.* **2009**, *74*, 910–913.
- (58) Wessig, P.; Matthes, A. Photochemical Synthesis and Properties of 1,6- and 1,8-Naphthalenophanes. *Molecules* **2013**, *18*, 1314–1324.
- (59) Tanaka, K.; Matsuyama, H.; Watanabe, M.; Fujimori, M. Synthesis and Biological Evaluation of Kendamycin and its Analogues. *J. Org. Chem.* **2014**, *79*, 9922–9947.
- (60) Sabitha, G.; AnkiReddy, P.; Das, S. K. The First Total Synthesis of Pectinolides D and E and Total Synthesis of Pectinolides D and E and Total Synthesis of Pectinolides A and C. *Synthesis* **2015**, *47*, 330–342.
- (61) Manikanta, G.; Nagarajum T.; Krishna, P. R. Total Synthesis of the Proposed Structures of the Novel Antimalarial Pyranone Crytorigidifoliol E. *Synthesis* **2016**, *48*, 4213–4220.
- (62) Ozanne, A.; Ponységu, L.; Depernet, D.; François, B.; Quideau, S. A Stabilized Formulation of IBX (SIBX) for Safe Oxidation Reactions Including a New Oxidative Demethylation of Phenolic Methyl Aryl Ethers. *Org. Lett.* **2003**, *5*, 2903–2906.
- (63) Kirkham, J. E. D.; Courtney, T. D. L.; Lee, V.; Baldwin, J. E. Asymmetric Synthesis of Cytotoxic Sponge Metabolites (*R*)-Strongylodiols A and B. *Tetrahedron Lett.* **2004**, *45*, 5645–5647.
- (64) Kirkham, J. E. D.; Courtney, T. D. L.; Lee, V.; Baldwin, J. E. Asymmetric Synthesis of Cytotoxic Sponge Metabolites (*R*)-Strongylodiols A and B and an Analogue. *Tetrahedron* **2005**, *61*, 7219–7232.

- (65) Tietze, L. F.; Singidi, R. R.; Gericke, K. M. Böckemeir, H.; Laatsch, H. Isolation, Enantioselective Total Synthesis and Structure Determination of the Anthrapyran Metabolite SS43405-e. *Eur. J. Org. Chem.* **2007**, 5875–5878.
- (66) Choi, P. J.; Rathwell, D. C. K.; Brimble, M. A. Synthesis of 6,6-Bisbenzanulated Spiroketal Related to the Rubromycins using a Double Intramolecular Hetero-Michael Addition (DIHMA). *Tetrahedron Lett.* **2009**, *50*, 3245–3248.
- (67) Fuwa, H.; Hirota, K.; Sasaki, M. A Concise Synthesis of the AB-Ring Fragment of (–)-Gambierol. *Heterocycles* **2012**, *86*, 127–132.
- (68) Novokshonova, I. A.; Novokshonov, V. V.; Medvedeva, A. S. An Efficient Oxidation of Element-Containing Propargyl Alcohols and Acetylenic γ -Diols by 2-Iodoxybenzoic Acid (IBX). *Synthesis* **2008**, 3797–3800.
- (69) Maeda, Y.; Kakiuchi, N.; Matsumura, S.; Nishimura, T.; Uemura, S. Oxovanadium Complex-Catalyzed Oxidation of Propargylic Alcohols Using Molecular Oxygen. *Tetrahedron Lett.* **2001**, *42*, 8877–8879.
- (70) Maeda, Y.; Kakiuchi, N.; Matsumura, S.; Nishimura, T.; Kawamura, T.; Uemura, S. Oxovanadium Complex-Catalyzed Aerobic Oxidation of Propargylic Alcohols. *J. Org. Chem.* **2002**, *67*, 6718–6724.
- (71) Maeda, Y.; Washitake, Y.; Nishimura, T.; Iwai, K.; Yamaguchi, T.; Uemura, S. Calcium Phosphate-Vanadate Apatite (CPVAP)-Catalyzed Aerobic Oxidation of Propargylic Alcohols with Molecular Oxygen. *Tetrahedron* **2004**, *60*, 9031–9036.
- (72) Shaina, V. B.; Jain, S. L.; Sain, B. Cobalt Phthalocyanine Catalyzed Aerobic Oxidation of Secondary Alcohols: An Efficient and Simple Synthesis of Ketones. *Tetrahedron Lett.* **2003**, *44*, 383–386.
- (73) Blay, G.; Cardona, L.; Fernández, I.; Pedro, J. R. Cobalt(III) Complex Catalyzed Aerobic Oxidation of Propargylic Alcohols. *Synthesis* **2007**, 3329–3332.
- (74) Shen, Y.-L.; Wu, W.-T.; Liu, Q.; Wu, G.-L.; Wu, L.-M. Reactions of Propargylic Alcohols with Nitric Oxide. *J. Chem. Res.* **2006**, 545–546.
- (75) Han, C.; Yu, M.; Sun, W.; Yao, X. Ligand-Promoted Copper Nanoparticles Catalyzed Oxidation of Propargylic Alcohols with TBHP or Air as Oxidant. *Synlett* **2011**, 2363–2368.
- (76) Han, Z.; Shinokubo, H.; Oshima, K. Selective Oxidation of Propargylic Alcohols into α,β -Acetylenic Aldehydes with a $\text{TiCl}_4/\text{Et}_3\text{N}$ System. *Synlett* **2001**, 1421–1422.
- (77) Schmieder-van der Vondervoort, L.; Bouttemy, S.; Padrón, J. M.; Le Bras, J.; Mouzart, J.; Alsters, P. L. Chromium Catalyzed Oxidation of (Homo)Allyl and (Homo)Propargylic Alcohols with Sodium Periodate to Ketones or Carboxylic Acids. *Synlett* **2002**, 243–246.
- (78) Luo, Q.-L.; Nan, W.-H.; Li, Y.; Chen, X. Oxidation of Alcohols to Carbonyl Compounds with Molecular Iodine in the Presence of Potassium *tert*-Butoxide. *ARKIVOC* **2014**, (iv) 350–361.
- (79) Yamaguchi, J.-i.; Sugiyama, S. Conjugate Addition of an Ynone Containing Azulene with a Tertiary Amine. *Tetrahedron Lett.* **2016**, *57*, 4514–4518.

- (80) Cupps, T. L.; Boutin, R. H.; Rapoport, H. α -Amino Acids as Chiral Educs for Asymmetric Products. The Synthesis of α -Amino- α,β -ynones. *J. Org. Chem.* **1985**, *50*, 3972–3979.
- (81) Adlington, R. M.; Baldwin, J. E.; Catterick, D.; Pritchard, G. J. The Synthesis of Pyrimidin-4-yl Substituted α -Amino Acids. A Versatile Approach from Alkynyl Ketones. *J. Chem. Soc., Perkin Trans. 1* **1999**, 855–866.
- (82) Alemany, C.; Bach, J.; Garcia, J.; López, M.; Rodríguez, A. B. A Synthetic Approach to 3-Hydroxy 4-Substituted Carboxylic Acids Based on the Stereoselective Reduction of 1-Trimethylsilyl-1-alkyn-2-ones. *Tetrahedron* **2000**, *56*, 9305–9312.
- (83) Carter, R. G.; Weldon, D. J. Studies Directed toward the Total Synthesis of Azaspiracid: Stereoselective Construction of C₁-C₁₂, C₁₃-C₁₉, and C₂₁-C₂₅ Fragments. *Org. Lett.* **2000**, *2*, 3913–3916.
- (84) Haddad, N.; Tan, J.; Farina, V. Convergent Synthesis of the Quinolone Substructure of BILN 2061 via Carbonylative Sonogashira Coupling/Cyclization. *J. Org. Chem.* **2006**, *71*, 5031–5034.
- (85) Jackson, M. M.; Leverett, C.; Toezko, J. F.; Roberts, J. C. An Unexpected Equilibrium Process Associated with a Standard Approach to Ynone Synthesis. *J. Org. Chem.* **2002**, *67*, 5032–5035.
- (86) Rauhala, V.; Nevalainen, M.; Koskinen, A. M. P. An Expedient Synthesis of Spiroketal: Model Studies for the Calyculin C₁₆-C₂₅ Fragment. *Tetrahedron* **2004**, *60*, 9199–9204.
- (87) Suzuki, T.; Usui, K.; Miyake, Y.; Namikoshi, K.; Nakada, M. First Total Synthesis of Antimitotic Compound (+)-Phomopsidin. *Org. Lett.* **2004**, *6*, 553–556.
- (88) Kobayashi, Y.; Fukuda, A.; Kimachi, T.; Ju-ichi, M.; Takemoto, Y. Asymmetric Synthesis of Macrolactin Analogue. *Tetrahedron Lett.* **2004**, *45*, 677–680.
- (89) Turunen, B. J.; Georg, G. I. Amino Acid-Derived Enaminones: A Study in Ring Formation Providing Valuable Asymmetric Synthons. *J. Am. Chem. Soc.* **2006**, *128*, 8702–8703.
- (90) Niphakis, M. J.; Turunen, B. J.; Georg, G. I. Synthesis of 6- and 7-Membered Cyclic Enaminones: Scope and Mechanism. *J. Org. Chem.* **2010**, *75*, 6793–6805.
- (91) Brummond, K. M.; Chen, D.; Painter, T. O.; Mao, S.; Seifried, D. D. A Rh(I)-Catalyzed Cycloisomerization Reaction Affording Cyclic Trienones. *Synlett* **2008**, 759–764.
- (92) Trost, B. M.; Li, Y. A New Catalyst for the Pd Catalyzed Alder Ene Reaction. A Total Synthesis of (+)-Cassiol. *J. Am. Chem. Soc.* **1996**, *118*, 6625–6633.
- (93) Gonçalves-Martin, M. G.; Saxer, A.; Renaud, P. A Practical Synthesis of (*S*)-Cyclopent-2-enol. *Synlett* **2009**, 2801–2802.
- (94) Raghavan, S.; Mustafa, S.; Sridhar, B. A Versatile Route to (*E*)- and (*Z*)-Hydroxy-3,4-unsaturated Disubstituted Sulfilimines and Their Haloamination Reaction. *J. Org. Chem.* **2009**, *74*, 4499–4507.
- (95) Ward, T. R.; Turunen, B. J.; Haack, T.; Neuenswander, B.; Shadrick, W.; Georg, G. I. Synthesis of a Quinolone Library from Ynones. *Tetrahedron Lett.* **2009**, *50*, 6494–6497.

- (96) Gouault, N.; Le Roch, M.; Cornée, C.; David, M.; Uriac, P. Synthesis of Substituted Pyrrolin-4-ones from Amino Acids in Mild Conditions via a Gold-Catalyzed Approach. *J. Org. Chem.* **2009**, *74*, 5614–5617.
- (97) Curran, D. P.; Sui, B. A “Shortant” Mosher Ester Method to Assign Configurations of Stereocenters in Nearly Symmetric Environments. Fluorous Mixture Synthesis and Structure Assignment of Petrocortyne A. *J. Am. Chem. Soc.* **2009**, *131*, 5411–5413.
- (98) Reddy, C. R.; Srikanth, B. Synthesis of the Tetrahydropyran Subunit C8-C20 Fragment) of (–)-Dactylolide and (–)-Zampanolide. *Synlett* **2010**, 1536–1538.
- (99) Reddy, C. R.; Reddy, G. B.; Srikanth, B. Stereoselective Synthesis of a Tetrahydropyranyl Diarylheptanoid, *ent*-Diospongin A. *Tetrahedron: Asymmetry* **2011**, *22*, 1725–1728.
- (100) Thornton, P. D.; Cameron T. S.; Burnell, D. J. Vinylogous Anionic Processes in the Formation and Interconversion of Tetracyclic Ring Systems. *Org. Biomol. Chem.* **2011**, *9*, 3447–3456.
- (101) García-Domínguez, P. Alvarez, R.; de Lera, A. R. Survey of Synthetic Approaches to Natural (Peyssonenyne) and Unnatural Acetoxyenediynes. *Eur. J. Org. Chem.* **2012**, 4762–4782.
- (102) Šenica, L.; Grošelj, U.; Kasunič, M.; Kočar, D.; Stanovnik, B.; Svete, J. Synthesis of Enaminone-Based Vinylogous Peptides. *Eur. J. Org. Chem.* **2014**, 3067–3071.
- (103) Pirc, S.; Bevk, D.; Golobič, A.; Stanovnik, B.; Svete, J. Transformation of Amino Acids into Nonracemic 1-(Heteroaryl)ethanamides by Enamino Ketone Methodology. *Helv. Chim. Acta* **2006**, *89*, 30–44.
- (104) Koswatta, P. B.; Das, J.; Yousufuddin, M.; Lovely, C. J. Studies towards the *Leucetta*-Derived Alkaloids Spirocalcaridine A and B – Possible Biosynthetic Implications. *Eur. J. Org. Chem.* **2015**, 2603–2613.
- (105) Nelson, R.; Gulías, M. Mascareñas, J. L.; López, F. Concise Enantioselective, and Versatile Synthesis of (–)-Englerin A Based on a Platinum-Catalyzed [4C+3C] Cycloaddition of Allenediene. *Angew. Chem., Int. Ed.* **2016**, *55*, 14359–14363.
- (106) Vu, H.-D.; Renault, J.; Roisnel, T.; Gouault, N.; Uriac, P. Synthesis of 3-Substituted Indolizidines from Amino-Ynones Derivatives. *Tetrahedron Lett.* **2016**, *57*, 3036–3038.
- (107) Chabala, J. C.; Vicent, J. E. The Preparation of α,β -Acetylenic Ketones by Condensation of Lithium Acetylides with Lactones. *Tetrahedron Lett.* **1978**, *41*, 1819–1823.
- (108) Shimizu, Y.; Kiyota, H.; Oritani, T. Synthesis of the Spiroacetal Parts of Spirofungin A and B. *Tetrahedron Lett.* **2000**, *41*, 3141–3144.
- (109) Leuwenburg, M. A.; Picasso, S.; Overkleeft, H. S.; van der Marel, G. A.; Vogel, P.; van Boom, J. H. A Short and Flexible Route to Aza- β -(1 \rightarrow 6)-C-disaccharides: Selective α -Glycosidase Inhibitors. *Eur. J. Org. Chem.* **1999**, 1185–1189.
- (110) Sánchez-Obregón, R.; Ortiz, B.; Walls, F.; Yuste, F.; García-Ruano, J. L. Asymmetric Synthesis of α -Acetylenic Epoxides. *Tetrahedron: Asymmetry* **1999**, *10*, 837–955.

- (111) Sakamoto, K.; Honda, E.; Ono, N. A Novel Synthetic Approach to Benzo[*h*]chromanes via Sequential Intramolecular Alkynoyl Transfer Followed by 6-*endo* Ring Closure. *Tetrahedron Lett.* **2000**, *41*, 1819–1823.
- (112) Dounay, A. B.; Urbanek, R. A.; Frydrychowski, V. A.; Forsyth, C. J. Expedient Access to the Okadaic Acid Architecture: A Novel Synthesis of the C1-C27 Domain. *J. Org. Chem.* **2001**, *66*, 925–938.
- (113) Wessig, P.; Müller, G.; Pick, C.; Matthes, A. The Photo-Dehydro-Diels–Alder (PDDA) Reaction—A Powerful Method for the Preparation of Biaryls. *Synthesis* **2007**, 464–477.
- (114) Kim, B. R.; Lee, H.-G.; Kang, S.-B.; Jung, K.-J.; Sung, G. H.; Kim, J.-J.; Lee, S.-G.; Yoon, Y.-J. Synthesis of β -Ketonitriles, α,β -Alknonones and Biscabinols from Esters using *tert*-Butoxide-Assisted (C=O)–C (i.e., Acyl–C) Coupling under Ambient Conditions. *Tetrahedron* **2013**, *69*, 10331–10336. Corrigendum: *Tetrahedron* **2014**, *70*, 1016.
- (115) Hsieh, M. T.; Lin, H.-C.; Kuo, S.-C. Synthesis of Fluazolone via the Application of Regioselective [3+2] Cyclocondensation and Nucleophilic Substitution-Cyclization Strategies. *Tetrahedron* **2016**, *72*, 5880–5885.
- (116) Morales-Serna, J. A.; Sauza, H.; Padrón de Jesús, G.; Gaviño, R.; García de la Mora, G.; Cárdenas, J. Facile and Efficient Addition of Terminal Alkynes to Benzotriazole Esters: Synthesis of *D-erythro*-Sphingosine Using Ynones as the Key Intermediate. *Tetrahedron Lett.* **2013**, *54*, 7111–7114.
- (117) Rad, M. N. S.; Bchrouz, S. Highly Efficient Copper- and Palladium-Free One-Pot Coupling of Alkynes with Sodium Carboxylate Salts Using Cyanuric and Magnesium Chloride. *Synlett* **2011**, 2562–2566.
- (118) Dieter, R. K. Reaction of Acyl Chlorides with Organometallic Reagents: A Banquet Table of Metals for Ketone Synthesis. *Tetrahedron* **1999**, *55*, 4177–4236.
- (119) Ashburn, B. O.; Carter, R. G.; Zakharov, L. N. Synthesis of Tetra-*ortho*-Substituted, Phosphorous-Containing and Carbonyl-Containing Biaryls Utilizing a Diels–Alder Approach. *J. Am. Chem. Soc.* **2007**, *129*, 9109–9116.
- (120) Guo, H.; La Clair, J. J.; Masler, E. P.; O’Doherty, G. A.; Xing, V. De Novo Asymmetric Synthesis and Biological Analysis of the Daumone Pheromones in *Cenorhabditis elegans* and in the Soybean Cyst Nematode *Heterodera glycines*. *Tetrahedron* **2016**, *72*, 2280–2286.
- (121) Smith, C. D.; Tehabnenko, K.; Adlington, R. M.; Baldwin, J. E. Synthesis of Linked Heterocycles via Use of Bis-Acetylenic Compounds. *Tetrahedron Lett.* **2006**, *47*, 3209–3212.
- (122) Wang, B.; Bonin, M.; Micouin, L. A Straightforward Synthesis of Ynones by Reaction of Dimethylalkynylaluminum Reagents with Acyl Chlorides. *J. Org. Chem.* **2005**, *70*, 6126–6128.
- (123) Taylor, C.; Bolshan, Y. Metal-Free Synthesis of Ynones from Acyl Chlorides and Potassium Alkynyltrifluoroborate Salts. *Org. Lett.* **2014**, *16*, 488–491.
- (124) Taylor, C. L.; Bolshan, Y. Metal-Free Synthesis of Ynones from Acyl Chlorides and Potassium Alkynyltrifluoroborate Salts. *J. Visual. Exp.* **2015**, *96*, 1–9.

- (125) Taylor, C.; Bolshan, Y. Metal-free Methodology for the Preparation of Sterically Hindered Alkynylphenols and its Application to the Synthesis of Flavones. *Tetrahedron Lett.* **2015**, *56*, 4392–4396.
- (126) Kim, B. J.; Matteson, D. S. Conversion of Alkyltrifluoroborates into Alkyldichloroboranes with Tetrachlorosilane in Coordinating Solvents. *Angew. Chem., Int. Ed.* **2004**, *43*, 3056–3058.
- (127) Nayyar, N. K.; Hutchinson, D. R.; Martinelli, M. J. Approach for the General Synthesis of Oxotetrahydroindoles via Intramolecular Cycloadditions of Azomethine Ylides with Tethered Alkynes. *J. Org. Chem.* **1997**, *62*, 982–991.
- (128) Allard, M.; Barnes, K.; Chen, X.; Cheung, Y.-Y.; Duffy, B.; Heap, C.; Inthavongsay, J.; Johnson, M.; Krishnamoorthy, R.; Manley, C.; Steffke, S.; Varughese, D.; Wang, R.; Wang, Y.; Schwartz, C. E. Total Synthesis of Resolvin E1. *Tetrahedron Lett.* **2011**, *52*, 2623–2626.
- (129) Zhu, S.; Wu, Y. Synthesis of the Anti-Melanogenic Glycerol Fatty Acid Ester Isolated from the Tuber-Barks of *Colocasia antiquorum* var. *esculeta*. *Synlett* **2014**, *25*, 261–264.
- (130) Koldobskii, A. B.; Solodova, F. V.; Godonikov, I. A.; Kalinin, V. N. 1-Ethoxyoxalyl-2-chloroacetylene as a New Dienophile in Diels-Alder Reactions. *Doklady Akad. Nauk SSSR* **2008**, *420*, 147–149.
- (131) Tian, S.-K.; Hong, R.; Deng, L. Catalytic Asymmetric Cyanosilylation of Ketones with Chiral Lewis Base. *J. Am. Chem. Soc.* **2003**, *125*, 9900–9901.
- (132) Chinchilla, R.; Nájera, C. The Sonogashira Reaction: A Booming Methodology in Synthetic Organic Chemistry. *Chem. Rev.* **2007**, *107*, 874–922.
- (133) Doucet, H.; Hierso, J.-C. Palladium-Based Catalytic Systems for the Synthesis of Conjugated Enynes by Sonogashira Reactions and Related Alkynylations. *Angew. Chem., Int. Ed.* **2007**, *46*, 834–871.
- (134) Chinchilla, R.; Nájera, C. Recent Advances in Sonogashira Reactions. *Chem. Soc. Rev.* **2011**, *40*, 5084–5121.
- (135) Bakherad, M. Recent Progress and Current Applications of Sonogashira Coupling Reaction in Water. *Appl. Organomet. Chem.* **2013**, *27*, 125–140.
- (136) Chinchilla, R.; Nájera, C. Chemicals from Alkynes with Palladium Catalysis. *Chem. Rev.* **2014**, *114*, 1783–1826.
- (137) Heravi, M. M.; Ghanbarian, M.; Ghalavand, N.; Nazari, N. Current Applications of the Sonogashira Reaction in the Synthesis of Heterocyclic Compounds: An Update. *Curr. Org. Chem.* **2018**, *22*, 1420–1457.
- (138) Tohda, Y.; Sonogashira, K.; Hagihara, N. A Convenient Synthesis of 1-Alkynyl Ketones and 2-Alkynamides. *Synthesis* **1977**, 777–778.
- (139) Karpov, A. S.; Müller, T. J. J. New Entry to a Three-Component Pyrimidine Synthesis by TMS-Ynones via Sonogashira Coupling. *Org. Lett.* **2003**, *5*, 3451–3454.
- (140) Karpov, A. S.; Müller, T. J. J. Straightforward Novel One-Pot Enaminone and Pyrimidine Synthesis by Coupling-Addition-Condensation Sequences. *Synthesis* **2003**, 2815–2826.

- (141) Karpov, A. S.; Oeser, T.; Müller, T. J. J. A Novel One-Pot Four-Component Access to Tetrahydro- β -Carbolines by a Coupling-Amination-aza-Annulation-Pictet–Spengler Sequence (CAAPS). *Chem. Commun.* **2004**, 1502–1503.
- (142) Yin, J.; Wang, X.; Liang, Y.; Wu, X.; Chem, B.; Ma, X. Synthesis of Ferrocenylethynyl Ketones by Coupling of Ferrocenylethyne with Acyl Chlorides. *Synthesis* **2004**, 331–333.
- (143) Chen, L.; Li, C.-J. A Remarkably Efficient Coupling of Acid Chlorides with Alkynes in Water. *Org. Lett.* **2004**, *6*, 3151–3153.
- (144) Cox, R. J.; Ritson, D. J.; Dane, T. A.; Berge, J.; Charmant, J. P. H.; Kantacha, A. Room Temperature Palladium Catalyzed Coupling of Acyl Chlorides with Terminal Alkynes. *Chem. Commun.* **2005**, 1037–1039.
- (145) Karpov, A. S.; Merkul, E.; Oeser, T.; Müller, T. J. J. A Novel One-Pot Three-Component Synthesis of 3-Halofurans and Sequential Suzuki Coupling. *Chem. Commun.* **2005**, 2581–2583.
- (146) Karpov, A. S.; Merkul, E.; Oeser, T.; Müller, T. J. J. One-pot Three-Component Synthesis of 3-Halofurans and 3-Chloro-4-iodofurans. *Eur. J. Org. Chem.* **2006**, 2991–3000.
- (147) Merkul, E.; Boersch, C.; Frank, W.; Müller, T. J. J. Three-Component Synthesis of *N*-Boc-4-iodopyrroles and Sequential One-Pot Alkynylation. *Org. Lett.* **2009**, *11*, 2269–2272.
- (148) Liu, H.-L.; Jiang, H.-F.; Zhang, M.; Ya, W.-J.; Zhu, Q.-H.; Tang, Z. One-Pot Three-Component Synthesis of Pyrazoles through a Tandem Coupling Cyclocondensation Sequence. *Tetrahedron Lett.* **2008**, *49*, 3805–3809.
- (149) Bernini, R.; Cacchi, S.; Fabrici, G.; Sferrazza, A. 1,2-Disubstituted 4-Quinolones via Copper-Catalyzed Cyclization of 1-(2-Halophenyl)-2-en-3-amin-1-ones. *Synthesis* **2009**, 1209–1219.
- (150) Bernini, R.; Cacchi, S.; Fabrici, G.; Filisti, E.; Sferrazza, A. 3-Aroylindoles via Copper-Catalyzed Cyclization of *N*-(2-Iodoaryl)enaminones. *Synlett* **2009**, 1480–1484.
- (151) Takahashi, I.; Morita, F.; Kusugaya, H.; Kitagawa, O. Catalytic Enantioselective Synthesis of Atropisomeric 2-Aryl-4-quinolinone Derivatives with an N-C Chiral Axis. *Tetrahedron: Asymmetry* **2012**, *23*, 1657–1662.
- (152) Miliutina, M.; Ivanov, A.; Ejaz, S. A.; Villiger, A.; Forashenko, V. O.; Langer, P. Diversity Oriented Synthesis of 6-Nitro- and 6-Aminoquinolones and Their Activity as Alkaline Phosphatase Inhibitors. *RSC Adv.* **2015**, *5*, 60054–60078.
- (153) Willy, B.; Müller, T. J. J. Regioselective Three-Component Synthesis of Highly Fluorescent 1,3,5-Trisubstituted Pyrazoles, *Eur. J. Org. Chem.* **2008**, 4157–4168.
- (154) Willy, B.; Müller, T. J. J. Rapid One-Pot, Four-Step Synthesis of Highly Fluorescent 1,3,4,5-Tetrasubstituted Pyrazoles. *Org. Lett.* **2011**, *13*, 2082–2085.
- (155) Denißen, M.; Nordmann, J.; Dziambor, J.; Mayer, B.; Frank, W.; Müller, T. J. J. Sequential Palladium-Catalyzed Coupling-Cyclocondensation-Coupling (C³) Four-Component Synthesis of Intensively Blue Luminescent Biarylsubstituted Pyrazoles. *RSC Adv.* **2015**, *5*, 33838–33854.

- (156) Liu, H. L.; Geng, Z.-F.; Zhang, S. Y.; Han, J. One-Pot Three-Component Synthesis of 3,5-Disubstituted Isoxazoles by a Coupling-Cyclocondensation Sequence. *Heterocycles* **2014**, *89*, 1221–1227.
- (157) Li, J.; Liu, J.; Lam, J. W. Y.; Tang, B. Z. Poly(arylene ynonylene) with an Aggregation-Enhanced Emission Characteristic: a Fluorescent Sensor for both Hydrazine and Explosive Detection. *RSC Adv.* **2013**, *3*, 8193–8196.
- (158) Islas, R. E.; Cárdenas, J.; Gaviño, R.; García-Rios, E.; Lomas-Romero, L.; Morales-Serna, J. A. Phosphinito Palladium(II) Complexes as Catalysts for the Synthesis of 1,3-Enynes, Aromatic Alkynes and Yrones. *RSC Adv.* **2017**, *7*, 9780–9789.
- (159) Chen, J.-Y.; Lin, T.-C.; Chen, S.-C.; Chen, A.-J.; Mou, C.-Y.; Tsai, F. Y. Highly-Efficient and Recyclable Nanosized MCM-41-Anchored Palladium Bipyridyl Complex-Catalyzed Coupling of Acyl Chlorides and Terminal Alkynes for the Formation of Yrones. *Tetrahedron* **2009**, *65*, 10134–10141.
- (160) Huang, B.; Yin, L.; Cai, M. A Phosphine-Free Heterogeneous Coupling of Acyl Chlorides with Terminal Alkynes Catalyzed by a MCM-41-Immobilized Palladium Complex. *New. J. Chem.* **2013**, *37*, 3137–3144.
- (161) Chen, Q.; Yao, F.; Yin, L.; Cai, M. A Highly-Efficient Heterogeneous Palladium-Catalyzed Cascade Three-Component Reaction of Acid Chlorides, Terminal Alkynes and Hydrazines Leading to Pyrazoles. *J. Organomet. Chem.* **2016**, *804*, 108–113.
- (162) Merkul, E.; Oeser, T.; Müller, T. J. J. One-Pot Three-Component Synthesis of Yrones by Decarbonylative Sonogashira Coupling. *Chem. – Eur. J.* **2009**, *15*, 5006–5011.
- (163) Gers, C. F.; Rosellen, J.; Merkul, E.; Müller, T. J. J. One-Pot Four-Component Synthesis of Pyrimidyl and Pyrazolyl Substituted Azulenes by Glyoxylation-Decarbonylative Alkynylation-Cyclocondensation Sequences. *Beilstein J. Org. Chem.* **2011**, *7*, 1173–1181.
- (164) Tokuyama, H.; Miyazaki, T.; Yokoshima, S.; Fukuyama, T. A Novel Palladium-Catalyzed Coupling of Thiol Esters with 1-Alkynes. *Synlett* **2003**, 1512–1514.
- (165) Miyazaki, T.; Han-ya, Y.; Tokuyama, H.; Fukuyama, T. New Odorless Protocols for the Synthesis of Aldehydes and Ketones from Thiol Esters. *Synlett* **2004**, 477–480.
- (166) Nakahata, T.; Fujimura, S.; Kuwahara, S. Total Synthesis of Pteridic Acids A and B. *Chem. – Eur. J.* **2006**, *12*, 4584–4593.
- (167) Habrant, D.; Stewart, A. J. W.; Koskinen, A. M. P. Towards the Total Synthesis of Calyculin C: Preparation of the C₁₃-C₂₅ Spirocyclic Core. *Tetrahedron* **2009**, *65*, 7927–7934.
- (168) Habrant, D.; Koskinen, A. M. P. Towards the Total Synthesis of Calyculin C: Preparation of the C₉-C₂₅ Spiroketal-Dipropionate Unit. *Org. Biomol. Chem.* **2010**, *8*, 4364–4373.
- (169) Fuwa, H.; Matsukida, S.; Sasaki, M. An Efficient Synthesis of 2,6-Disubstituted 2,3-Dihydro-4H-pyran-4-ones via Sonogashira Coupling of *p*-Toluenethiol Esters. *Synlett* **2010**, 1239–1242.

- (170) Fuwa, H.; Mizunuma, K.; Matsukida, S.; Sasaki, M. A New Strategy for the Synthesis of Substituted Dihydropyrans and Tetrahydropyrans via Palladium-Catalyzed Coupling of Thioesters. *Tetrahedron* **2011**, *67*, 4995–5010.
- (171) Kawaguchi, S.; Srivastava, P.; Engman, L. Palladium-Catalyzed Sonogashira Cross-Coupling of Organic Tellurides with Alkynes. *Tetrahedron Lett.* **2011**, *52*, 4120–4122.
- (172) Alonso, D. A.; Nájera, C.; Pacheco, M. C. Synthesis of Ynones by Palladium-Catalyzed Acylation of Terminal Alkynes with Acyl Chlorides. *J. Org. Chem.* **2004**, *69*, 1615–1619.
- (173) Palimkar, S. S.; Kumar, P. H.; Jogdand, N. R.; Daniel, T.; Lahoti, R. J.; Srinivasan, K. V. Copper-, Ligand- and Solvent-Free Synthesis of Ynones by Coupling Acid Chlorides with Terminal Alkynes. *Tetrahedron Lett.* **2006**, *47*, 5527–5530.
- (174) Palimkar, S. S.; Lahoti, R. J.; Srinivasan, K. V. A Novel One-Pot Three-Component Synthesis of 2,4-Disubstituted-3*H*-benzo[b] [1,4] Diazepines in Water. *Green Chem.* **2007**, *9*, 146–152.
- (175) Palimkar, S. S.; More, V. S.; Srinivasan, K. V. Simple and Efficient One-Pot, Three-Component, Solvent-Free Synthesis of β -Enaminones via Sonogashira Coupling-Michael Addition Sequences. *Synth. Commun.* **2008**, *38*, 1456–1469.
- (176) Atobe, S.; Masuno, H.; Sonoda, M.; Suzuki, Y.; Shinohara, H.; Shibata, S.; Ogawa, A. Pd-Catalyzed Coupling Reaction of Acid Chlorides with Terminal Alkynes Using 1-(2-Pyridylethynyl)-2-(2-thienylethynyl)benzene Ligand. *Tetrahedron Lett.* **2012**, *53*, 1764–1767.
- (177) Das, D.; Maiti, P.; Bagdi, A. K.; Ghosh, T.; Chattopadhyay, T.; Das, S.; Hajra, A.; Majee, A.; Zangrando, E. Synthesis, Structure and Catalytic Aspects of the Palladium(II) Complex [PdLCl₂] (where LH = 2-Formyl-4-methyl-6-*N*-ethylpiperidineiminomethylphenol). *Ind. J. Chem.* **2013**, *52A*, 863–867.
- (178) Bakherad, M.; Amin, A. H.; Keivanloo, A.; Bahranian, B.; Raessi, M. Using Pd–Salen Complex as an Efficient Catalyst for the Copper- and Solvent-Free Coupling of Acyl Chlorides with Terminal Alkynes under Aerobic Conditions. *Chin. Chem. Lett.* **2010**, *21*, 656–660.
- (179) Likhar, P. R.; Subhas, M. S.; Roy, M.; Roy, S.; Kantam, M. L. Copper-Free Sonogashira Coupling of Terminal Alkynes in the Presence of a Reusable Palladium Catalyst: An Improved Synthesis of 3-Iodochromenones (= 3-Iodo-4*H*-1-benzopyran-4-ones). *Helv. Chim. Acta* **2008**, *91*, 259–264.
- (180) Bakherad, M.; Keivanloo, A.; Bahramian, B.; Rajaie, M. A Copper- and Solvent-Free Coupling of Acyl Chlorides with Terminal Alkynes Catalyzed by a Polystyrene-Supported Palladium(0) Complex under Aerobic Conditions. *Tetrahedron Lett.* **2010**, *51*, 33–35.
- (181) Bakherad, M.; Keivanloo, A.; Bahramian, B.; Jajarmi, S. Synthesis of Ynones via Recyclable Polystyrene-Supported Palladium(0) Complex Catalyzed Acylation of Terminal Alkynes with Acyl Chlorides under Copper- and Solvent-Free Conditions. *Synlett* **2011**, 311–314.

- (182) Santra, S.; Dhara, K.; Ranjan, P.; Bera, P.; Dash, J.; Mandal, S. R. Supported Palladium Nanocatalyst for Copper-Free Acyl Sonogashira Reactions: One-Pot Multicomponent Synthesis of *N*-Containing Heterocycles. *Green Chem.* **2011**, *13*, 3238–3247.
- (183) Santra, S.; Ranjan, P.; Bera, P.; Ghosh, P.; Mandal, S. K. Anchored Palladium Nanoparticles onto Single Walled Carbon Nanotubes: Efficient Recyclable Catalyst for *N*-Containing Heterocycles. *RSC Adv.* **2012**, *2*, 7523–7533.
- (184) Navidi, M.; Movassagh, B.; Rayati, S. Multi-Walled Carbon Nanotubes Functionalized with a Palladium(II)-Schiff Base Complex: A Recyclable and Heterogeneous Catalyst for the Copper-, Phosphorous-, and Solvent-Free Synthesis of Ynones. *Appl. Cat. A: General* **2013**, *452*, 24–28.
- (185) Hossain, S.; Park, J.; Park, M.; Jin, M. Silica Gel-Supported Palladium Catalyst for the Acyl Sonogashira Reaction. *J. Kor. Chem. Soc.* **2013**, *57*, 411–415.
- (186) Sharma, R. K.; Yadav, M.; Gaur, R.; Gupta, R.; Adholeya, A.; Gawande, M. B. Synthesis of Iron Oxide Palladium Nanoparticles and Their Catalytic Applications for Direct Coupling of Acyl Chlorides and Terminal Alkynes. *ChemPlusChem* **2016**, *81*, 1312–1319.
- (187) Yu, B.; Sun, H.; Xie, Z.; Zhang, G.; Xu, L.-W.; Zhang, W.; Gao, Z. Privilege Ynone Synthesis via Palladium-Catalyzed Alkynylation of “Super-Active Esters”. *Org. Lett.* **2015**, *17*, 3298–3301.
- (188) Cui, M.; Wu, H.; Jian, J.; Wang, H.; Liu, C.; Daniel, S.; Zeng, Z. Palladium-Catalyzed Sonogashira Coupling of Amides: Access to Ynones via C-N Bond Cleavage. *Chem. Commun.* **2016**, *52*, 12076–12079.
- (189) Castro, C. E.; Stephens, R. D. The Substitution of Aryl Iodides with Cuprous Acetylides. A Synthesis of Tolanes and Heterocycles. *J. Org. Chem.* **1963**, *28*, 3313–3315.
- (190) Chowdhury, C.; Kundu, N. G. Copper(I)-Catalyzed Acylation of Terminal Alkynes. *Tetrahedron Lett.* **1996**, *37*, 7323–7324.
- (191) Chowdhury, C.; Kundu, N. G. Studies on Copper(I)-Catalyzed Cross-Coupling Reactions: A Convenient and Facile Method for the Synthesis of Diversely Substituted α,β -Acetylenic Ketones. *Tetrahedron* **1999**, *55*, 7011–7016.
- (192) Mohammadi, E.; Movassagh, B.; Navidi, M. Palladium- and Solvent-Free Synthesis of Ynones by Copper(I)-Catalyzed Acylation of Terminal Alkynes with Acyl Chlorides under Aerobic Conditions. *Helv. Chim. Acta* **2014**, *97*, 70–75.
- (193) Yin, W.; He, H.; Zhang, Y.; Luo, D.; He, H. A Highly Active CuI/TMEDA Catalytic System for the Coupling Reaction of Acyl Chlorides with Terminal Alkynes under Solvent-Free Conditions. *Synthesis* **2014**, *46*, 2617–2620.
- (194) Sun, W.; Wang, Y.; Wu, X.; Yao, X. Palladium-, Ligand-, and Solvent-Free Synthesis of Ynones by the Coupling of Acyl Chlorides and Terminal Alkynes in the Presence of Reusable Copper Nanoparticles Catalyst. *Green Chem.* **2013**, *15*, 2356–2360.
- (195) Busale, M. A.; Sasaki, T.; Bhanage, B. M. A Facile and Rapid Route for the Synthesis of Cu/Cu₂O Nanoparticles and their Application in the Sonogashira Coupling

- Reaction of Acyl Chlorides and Terminal Alkynes. *Catal. Sci. Technol.* **2014**, *4*, 4274–4280.
- (196) Wang, K.; Yang, L.; Zhao, W.; Cao, L.; Sun, Z.; Zhang, F. A Facile Synthesis of Copper Nanoparticles Supported on an Ordered Mesoporous Polymer as an Efficient and Stable Catalyst for Solvent-Free Sonogashira Coupling Reactions. *Green Chem.* **2017**, *19*, 1949–1957.
- (197) Reddy, K. R.; Suresh, M.; Kantam, M. L.; Bhargava, S. K.; Srinivasu, P. Palladium-Free Highly Efficient Mesoporous Tin Silicates Catalytic Acyl Sonogashira Coupling Reaction. *Ind. Eng. Chem. Res.* **2014**, *53*, 18630–18636.
- (198) Guo, M.; Li, D.; Zhang, Z. Novel Synthesis of 2-Oxo-3-butynoates by Copper-Catalyzed Cross-Coupling Reaction of Terminal Alkynes and Monooxalyl Chloride. *J. Org. Chem.* **2003**, *68*, 10172–10174.
- (199) Merkul, E.; Dohe, J.; Gers, C.; Rominger, F.; Müller, T. J. J. Three-Component Synthesis of Ynediones by a Glyoxylation/Stephen–Castro Coupling Sequence. *Angew. Chem., Int. Ed.* **2011**, *50*, 2966–2969.
- (200) Boersch, C.; Merkul, E.; Müller, T. J. J. Catalytic Synthesis of N-Heterocyclic Ynones and Ynediones by *in situ* Activation of Carboxylic Acids with Oxalyl Chloride. *Angew. Chem., Int. Ed.* **2011**, *50*, 10448–10452.
- (201) Ito, H.; Arimoto, K.; Senseu, H.; Hosomi, A. A Direct Alkynyl Group Transfer from Silicon to Copper: New Preparation Method of Alkynylcopper(I) Reagents. *Tetrahedron Lett.* **1997**, *38*, 3977–3980.
- (202) Gallagher, W. P.; Meleczka, Jr. R. E. PMHS-Mediated Coupling of Alkynes or Benzothiazoles with Various Electrophiles: Application to the Synthesis of (–)-Akolactone A. *J. Org. Chem.* **2003**, *68*, 6775–6779.
- (203) Nishihara, Y.; Saito, D.; Inoue, E.; Okada, Y.; Miyazaki, M.; Inoue, Y.; Takagi, K. Palladium- and Base-Free Synthesis of Conjugated Ynones by Cross-Coupling Reactions of Alkynylboronates with Acid Chlorides Mediated by CuCl. *Tetrahedron Lett.* **2010**, *51*, 306–308.
- (204) Lee, K. Y.; Lee, M. J.; Kim, J. N. Facile Synthesis of α,β -Acetylenic Ketones and 2,5-Disubstituted Furans: Consecutive Activation of Triple and Double Bond with ZnBr₂ Toward the Synthesis of Furan Ring. *Tetrahedron* **2005**, *61*, 8705–8710.
- (205) Keivanloo, A.; Bakherad, M.; Bahramian, B.; Baratnia, S. Silicon-Supported Zinc Bromide (ZnBr₂/SiO₂): A Highly Efficient Heterogeneous Catalyst for Coupling of Acid Chlorides with Terminal Alkynes. *Tetrahedron Lett.* **2011**, *52*, 1498–1502.
- (206) Ganlepan, P.; Parthasarathy, K.; Su, T.-H.; Cheng, C.-H. Iron-Catalyzed Synthesis of β -Chlorovinyl and α,β -Alkynyl Ketones from Terminal and Silylated Alkynes with Acyl Chlorides. *Adv. Synth. Catal.* **2012**, *354*, 457–468.
- (207) Shen, Q.; Huang, W.; Wang, J.; Zhou, X. La[N(SiMe₃)₂]₃/RNH₂ Catalyzed Monoaddition of Terminal Alkynes to Nitriles: A Novel and Concise Access to the Synthesis of Ynones. *Organometallics* **2008**, *27*, 301–303.
- (208) Ding, H.; Lu, C.; Hu, X.; Zhao, B.; Wu, B.; Yao, Y. Addition of Terminal Alkynes to Aromatic Nitriles Catalyzed by Divalent Lanthanide Amides Supported by Amidates: Synthesis of Ynones. *Synthesis* **2013**, *24*, 1269–1274.

- (209) Morimoto, T.; Kakiuchi, K. Evolution of Carbonylation Catalysis: No Need of Carbon Monoxide. *Angew. Chem., Int. Ed.* **2004**, *43*, 5580–5588.
- (210) Frisch, A. C.; Beller, M. Catalyst for Cross-Coupling Reactions with Non-Activated Alkyl Halides. *Angew. Chem., Int. Ed.* **2005**, *44*, 674–688.
- (211) Beletskaya, I. P.; Ananikov, V. P. Unusual Influence of the Structures of Transition Metal Complexes on Catalytic C-S and C-Se Bond Formation under Homogeneous and Heterogeneous Conditions. *Eur. J. Org. Chem.* **2007**, 3431–3444.
- (212) Breenfürer, A.; Neumann, H.; Beller, M. Palladium-Catalyzed Carbonylation Reactions of Aryl Halides and Related Compounds. *Angew. Chem., Int. Ed.* **2009**, *48*, 4114–4133.
- (213) Grigg, R.; Mutton, S. P. Pd-Catalyzed Carbonylations: Versatile Technology for Discovery and Process Chemists. *Tetrahedron* **2010**, *66*, 5515–5548.
- (214) Feng, X.-F.; Neuman, H.; Beller, M. Palladium-Catalyzed Carbonylative Coupling Reactions between Ar-X and Carbon Nucleophiles. *Chem. Soc. Rev.* **2011**, *40*, 4986–5009.
- (215) Gadge, S. T.; Bhanage, B. M.; Recent Developments in Palladium-Catalyzed Carbonylation Reactions. *RSC Adv.* **2014**, *4*, 10367–10389.
- (216) Sumino, S.; Fusano, A.; Fukuyama, T.; Ryu, I. Carbonylation Reactions of Alkyl Iodides through the Interplay of Carbon Radicals and Pd Catalysis. *Acc. Chem. Res.* **2014**, *47*, 1563–1574.
- (217) Gautam, P.; Bhanage, B. M. Recent Advances in the Transition Metal Catalyzed Carbonylation of Alkynes, Arenes and Aryl Halides using CO surrogates. *Catal. Sci. Technol.* **2015**, *5* 4663–4702.
- (218) Beller, M.; Wu, X. F. *Transition Metal Catalyzed Carbonylation Reactions: Carbonylative Activation of C-X Bonds*. Springer-Verlag, Berlin-Heidelberg, 2013.
- (219) Kobayashi, T.; Tanaka, M. Carbonylation of Organic Halides in the Presence of Terminal Acetylenes; Novel Acetylenic Ketone Synthesis. *Chem. Commun.* **1981**, 333–334.
- (220) Mohamed Ahmed, M. S.; Mori, A. Carbonylative Sonogashira Coupling of Terminal Alkynes with Aqueous Ammonia. *Org. Lett.* **2003**, *5*, 3057–3060.
- (221) Mohamed Ahmed, M. S.; Sekiguchi, A.; Masui, K.; Mori, A. Aqueous Ammonia as a New Activator for Sonogashira Coupling. *Bull. Chem. Soc. Jpn.* **2005**, *78*, 160–168.
- (222) Mohamed Ahmed, M. S.; Kobayashi, K.; Mori, A. One-Pot Construction of Pyrazoles and Isoxazoles with Palladium-Catalyzed Four-Component Coupling. *Org. Lett.* **2005**, *7*, 4487–4489.
- (223) Karpov, A. S.; Merkul, E.; Rominger, F.; Müller, T. J. J. Concise Synthesis of Meridianins by Carbonylative Alkynylation and a Four-Component Pyrimidine Synthesis. *Angew. Chem., Int. Ed.* **2005**, *44*, 6951–6956.
- (224) Ma, W.; Li, X.; Yang, J.; Liu, Z.; Chen, B.; Pan, X. A convenient Synthesis of Aryl Ferrocenylethynyl Ketones and 2-Ferrocenyl-4H-chromen-4-ones via Palladium-Catalyzed Carbonylation Coupling. *Synthesis* **2006**, 2489–2492.

- (225) Fehér, C.; Kuik, Á.; Márk, L.; Kollár, L.; Skoda-Földes, R. A Two-Step Synthesis of Ferrocenyl Pyrazole and Pyrimidine Derivatives Based on Carbonylative Sonogashira Coupling of Iodoferrocene. *J. Organomet. Chem.* **2009**, *694*, 4036–4041.
- (226) Stonehouse, J. P.; Smith, N.; Stocks, M. J.; Sviridov, S. I.; Utkina, L. M. One-Pot Four-Component Reaction for the Generation of Pyrazoles and Pyrimidines. *Synlett* **2008**, 100–104.
- (227) Kim, W.; Park, K.; Park, A.; Choe, J.; Lee, S. Pd-Catalyzed Selective Carbonylative and Non-Carbonylative Couplings of Propiolic Acid: One-Pot Synthesis of Diarylalkynones. *Org. Lett.* **2013**, *15*, 1654–1657.
- (228) Huang, Y.; Alper, H. Stereospecific Palladium(II)-Catalyzed Cyclocarbonylation of 3-Aryl-1-propynes and Iodoarenes or Acyl Chlorides. *J. Org. Chem.* **1991**, *56*, 4534–4536.
- (229) Delaude, L.; Masden, A. M.; Alper, H. Coupling and Carbonylation of Iodoaromatic and Terminal Alkynols Catalyzed by a Dimeric Palladium Hydroxide. *Synthesis* **1994**, 1149–1151.
- (230) Kiji, J.; Okano, T.; Kimura, H.; Saiki, K. Palladium-Catalyzed Carbonylative Coupling of Iodobenzene and 2-Methyl-3-butyn-2-ol under Biphasic Conditions: Formation of Furanones. *J. Mol. Catal. A: Chem.* **1998**, *130*, 95–100.
- (231) Arcadi, A.; Cacchi, S.; Martinelli, F.; Pace, P.; Sanzi, G. The Palladium-Catalyzed Carbonylative Coupling of 5-(Trimethylsilylethynyl)-3',5'-di-O-acetyl-2'-deoxyuridine and 1-Alkynes with Aryl Iodides. *Synlett* **1995**, 823–824.
- (232) Bishop, B. C.; Brands, K. M. J.; Gibb, A.D.; Kennedy, D. J. Regioselective Synthesis of 1,3,5-Substituted Pyrazoles from Acetylenic Ketones and Hydrazines. *Synthesis* **2004**, 43–52.
- (233) Kang, O.-K.; Lim, K.-H.; Ho, P.-S.; Kim, W.-Y. Synthesis of Alkynyl Ketones via Palladium- and Copper-Catalyzed Carbonylative Cross Coupling of Iodonium Salts with Alk-1-yne. *Synthesis* **1997**, 874–876.
- (234) Luo, S.-L.; Liang, Y.-M.; Liu, C.-M.; Ma, Y.-X. One-Step to Alkynyl Ketones via Cross-Coupling of Iodine Heterocyclic Compounds with 1-Alkynes. *Synth. Commun.* **2001**, *31*, 343–347.
- (235) Liang, B.; Huang, M.; You, Z.; Xiong, Z.; Lu, K.; Fathi, R.; Chen, J.; Yang, Z. Pd-Catalyzed Copper-Free Carbonylative Sonogashira Reaction of Aryl Iodides with Alkynes for the Synthesis of Alkynyl Ketones and Flavones by using Water as a Solvent. *J. Org. Chem.* **2005**, *70*, 6097–6100.
- (236) Li, C.; Li, X.; Zhu, Q.; Chen, H.; Lv, Q.; Chen, B. Convenient Synthesis of Ferrocenylethynyl Ketones via Carbonylative Coupling of Ferrocenylethyne with Aryl Iodides by Using Water as Solvent. *Cat. Lett.* **2009**, *127*, 152–157.
- (237) Kukuyama, T.; Yamaura, R.; Ryu, I. Synthesis of Acetylenic Ketones by a Pd-Catalyzed Carbonylative Three-Component Coupling Reaction in [bmim]PF₆. *Can. J. Chem.* **2005**, *83*, 711–715.
- (238) Rahman, M. T.; Fukuyama, T.; Kamata, M.; Sato, M.; Ryu, I. Low Pressure Pd-Catalyzed Carbonylation in an Ionic Liquid Using a Multiphase Microflow Reactor. *Chem. Commun.* **2006**, 2236–2238.

- (239) Sans, V.; Trzeciak, A. M.; Luis, S.; Ziólkowski, J. J. PdCl₂[P(OPh)₃]₂ Catalyzed Coupling and Carbonylative Coupling of Phenylacetylenes with Aryl Iodides in Organic Solvents and in Ionic Liquids. *Cat. Chem.* **2006**, *109*, 37–41.
- (240) Nicolaou, K. C.; Sarlah, D.; Shaw, D. M. Total Synthesis and Revised Structure of Biyouyanagin A. *Angew. Chem., Int. Ed.* **2007**, *46*, 4708–4711.
- (241) Awuah, E.; Capretta, A. Access to Flavones via a Microwave-Assisted, One-Pot Sonogashira-Carbonylation-Annulation Reaction. *Org. Lett.* **2009**, *11*, 3210–3213.
- (242) Yang, Q.; Alper, H. Synthesis of Chromones via Palladium-Catalyzed Ligand-Free Cyclocarbonylation of *o*-Iodophenols with Terminal Acetylenes in Phosphonium Salt Ionic Liquids. *J. Org. Chem.* **2010**, *75*, 948–950.
- (243) Genelot, M.; Bendjeriou, A.; Dufaud, V.; Djakovitch, L. Optimized Procedures for the One-Pot Selective Synthesis of Indoxyls and 4-Quinolones by a Carbonylative Sonogashira/Cyclization Sequence. *Appl. Cat. A: General* **2009**, *369*, 125–132.
- (244) Abbiati, G.; Arcadi, A.; Marinelli, F.; Rossi, E. An Efficient Synthesis of 2,4-Substituted [1,8]Naphthyridines from 3-(2-Amino-5-methylpyridin-3-yl)-1-arylprop-2-yn-1-ones. *Synthesis* **2002**, 1912–1916.
- (245) Fusano, A.; Fukuyama, T.; Nishitani, S.; Inouye, T.; Ryu, I. Synthesis of Alkyl Alkynyl Ketones by Pd/Light-Induced Three-Component Coupling Reactions of Iodoalkenes, CO and 1-Alkynes. *Org. Lett.* **2010**, *12*, 2410–2413.
- (246) Wu, X.-F.; Neumann, H.; Beller, M. A General and Convenient Palladium-Catalyzed Carbonylative Sonogashira Coupling of Aryl Bromides. *Chem. – Eur. J.* **2010**, *16*, 12104–12107.
- (247) Fu, X.-F.; Neumann, H.; Beller, M. Palladium-Catalyzed Carbonylative Coupling of Benzyl Chlorides with Terminal Alkynes to give 1,4-Diaryl-3-butyn-2-ones and Related Furanones. *Org. Biomol. Chem.* **2011**, *9*, 8003–8005.
- (248) Wu, X.-F.; Sundararaju, B.; Anbarasan, P.; Neumann, H.; Dixneuf, P. H.; Beller, M. A General Cyclocarbonylation of Aryl Bromides and Triflates with Acetylenes: Palladium-Catalyzed Synthesis of 3-Alkylidenefuran-2-ones. *Chem. – Eur. J.* **2011**, *17*, 8014–8017.
- (249) Wu, X. F.; Sundararaju, B.; Neumann, H.; Dixneuf, P. H.; Beller, M. A General Palladium-Catalyzed Carbonylative Sonogashira Coupling of Aryl Triflates. *Chem. – Eur. J.* **2011**, *17*, 106–110.
- (250) Neumann, K. T.; Laursen S. R.; Linhardt, A. T.; Bang-Andersen, B.; Skrydstrup, T. Palladium-Catalyzed Carbonylative Sonogashira Coupling of Aryl Bromides Using Near Stoichiometric Carbon Monoxide. *Org. Lett.* **2014**, *16*, 2216–2219.
- (251) Hermange, P.; Lindhardt, A. T.; Taaning, R. H.; Bjerglund, K.; Lupp, D.; Skrydstrup, T. Ex *in situ* Generation of Stoichiometric and Substoichiometric ¹²CO and ¹³CO and Its Efficient Incorporation in Palladium Catalyzed Aminocarbonylations. *J. Am. Chem. Soc.* **2011**, *133*, 6061–6071.
- (252) Wu, X. F.; Neumann, H.; Beller, M. Convenient and General Palladium-Catalyzed Carbonylative Sonogashira Coupling of Aryl Amines. *Angew. Chem., Int. Ed.* **2011**, *50*, 11142–11146.

- (253) Li, W.; Wu, X-F. Palladium-Catalyzed Carbonylative Sonogashira Coupling between Aryl Triazenes and Alkynes. *Org. Biomol. Chem.* **2015**, *13*, 5090–5093.
- (254) Xue, L.; Shi, L.; Han, Y.; Xia, C.; Huynh, H. V.; Li, F. Pd-Carbene Catalyzed Carbonylation Reactions of Aryl Iodides. *Dalton Trans.* **2011**, *40*, 7632–7638.
- (255) Dasgupta, A.; Ramkumar, V.; Sankararaman, S. Synthesis of Fluorescent 1,3-Diarylpropynones by Carbonylative Alkynylation Reaction Using (Phosphine) (1,2,3-triazol-5-ylidene) Palladium Complexes as Catalysts. *Eur. J. Org. Chem.* **2016**, 4817–4823.
- (256) Tan, C.; Wang, P.; Lin, H.; Zhao, X.-L.; Lu, Y.; Liu, Y. Bifunctional Ligands in Combination with Phosphines and Lewis Acidic Phospheniums for the Carbonylative Sonogashira Reaction. *Chem. Commun.* **2015**, *51*, 10871–10874.
- (257) Ramesh, C.; Kubota, Y.; Miwa, M.; Sugi, Y. Highly Selective and Efficient Catalyst for Carbonylation of Aryl Iodides: Dimeric Palladium Complex Containing Carbon-Palladium Covalent Bond. *Synthesis* **2002**, 2171–2173.
- (258) Gautan, P.; Bhanage, B. M. Oxime Palladacycle Catalyzed Carbonylative Sonogashira Cross-Coupling with High Turnovers in PEG as a Benign and Recyclable Solvent System. *ChemistrySelect* **2016**, *1*, 5463–5470.
- (259) Nájera, C. Oxime-Derived Palladacycles: Applications in Catalysis. *ChemCatChem* **2016**, *8*, 1865–1881.
- (260) Iizuka, M.; Kondo, Y. Palladium-Catalyzed Alkynylcarbonylation of Aryl Iodides with the Use of Mo(CO)₆ in the Presence of *t*Bu₃P Ligand. *Eur. J. Org. Chem.* **2007**, 5180–5182.
- (261) Friis, S. D.; Taaning, R. H.; Lindhardt, A. T.; Skrydstrup, T. Silicarboxylic Acids as Efficient Carbon Monoxide Releasing Molecules: Synthesis and Application of Palladium-Catalyzed Carbonylation Reactions. *J. Am. Chem. Soc.* **2011**, *133*, 18114–18117.
- (262) Li, H.; Neuman, H.; Beller, M. Wu, X.-F. Aryl Formate as Bifunctional Reagent: Applications in Palladium-Catalyzed Carbonylative Coupling Reactions Using *in situ* Generated CO. *Angew. Chem., Int. Ed.* **2014**, *53*, 3183–3186.
- (263) Hansen, S. V. F.; Ulven, T. Oxalyl Chloride as a Practical Carbon Monoxide Source for Carbonylation Reactions. *Org. Lett.* **2015**, *17*, 2832–2835.
- (264) Markovič, M.; Lopatka, P.; Koš, P.; Gracza, T. Zn-Mediated Reduction of Oxalyl Chloride Forming CO and Its Application in Carbonylation Reactions. *Org. Lett.* **2015**, *17*, 5618–5621.
- (265) Liu, J.; Chen, J.; Xia, C. A Simple and Efficient Recyclable Phosphine-Free Catalytic System for Alkoxy carbonylation and Carbonylative Sonogashira Coupling Reactions of Aryl Iodides. *J. Catal.* **2008**, *253*, 50–56.
- (266) Hao, W.; Sha, J.; Sheng, S.; Cai, M. The First Heterogeneous Carbonylative Sonogashira Reaction Catalyzed by MCM-41-Supported Bidentate Phosphine Palladium(0) Complex. *J. Mol. Catal. A: Chem.* **2009**, *298*, 94–98.
- (267) Liu, J.; Peng, X.; Sun, W.; Zhao, Y.; Xia, C. Magnetically Separable Pd Catalyst for Carbonylative Sonogashira Coupling Reactions for the Synthesis of α,β -Alkynyl Ketones. *Org. Lett.* **2008**, *10*, 3933–3936.

- (268) Wang, Y.; Liu, J.; Xia, C. Cross-Linked Polymer Supported Palladium Catalyzed Carbonylative Sonogashira Coupling Reaction in Water. *Tetrahedron Lett.* **2011**, *52*, 1587–1591.
- (269) Genelot, M.; Dufaud, V.; Djakovitch, L. Carbonylative Sonogashira Coupling in the Synthesis of Yrones: A Study of “Boomerang” Phenomena. *Adv. Synth. Catal.* **2013**, *355*, 2604–2616.
- (270) De Coste, J. B.; Peterson, G. W.; Jasuja, H.; Glover, T. G.; Huang, Y.-G.; Walton, K. S. Stability and Degradation Mechanism of Metal-Organic Frameworks Containing the $Zr_6O_4(OH)_4$ Secondary Building Unit. *J. Mater. Chem. A* **2013**, *1*, 5642–5650.
- (271) Bai, C.; Jian, S.; Yao, X.; Li, Y. Carbonylative Sonogashira Coupling of Terminal Alkynes with Aryl Iodides under Atmospheric Pressure of CO Using Pd(II)@MOF as the Catalyst. *Catal. Sci. Technol.* **2014**, *4*, 3261–3267.
- (272) Zhao, H.; Cheng, M.; Zhang, J.; Cai, M. Recyclable and Reusable $PdCl_2(PPh_3)_2/PEG-2000/H_2O$ System for the Carbonylative Sonogashira Coupling Reaction of Aryl Iodides with Alkynes. *Green Chem.* **2014**, *16*, 2515–2522.
- (273) Behr, A.; Henze, G.; Schomacker, R. Thermoregulated Liquid/Liquid Catalyst Separation and Recycling. *Adv. Synth. Catal.* **2006**, *348*, 1485–1495.
- (274) Hao, Y.; Jiang, J.; Wang, Y.; Jin, Z. The Thermoregulated Ligand-Palladium-Catalyzed Carbonylative Sonogashira Coupling of Aryl Iodides with Terminal Alkynes in Water. *Appl. Organometal. Chem.* **2015**, *29*, 608–611.
- (275) Chavan, S. P.; Varadwaj, G. B. B.; Parida, K.; Bhanage, B. M. Palladium Anchored on Amine-Functionalized K10 as an Efficient, Heterogeneous and Reusable Catalyst for Carbonylative Sonogashira Reaction. *Appl. Catal. A: General* **2015**, *506*, 237–243.
- (276) Chavan, S. P.; Varadwaj, G. B. B.; Parida, K. M.; Bhanage, B. M. Solvent-Switchable Regioselective Synthesis of Aurones and Flavones Using Palladium-Supported Amine-Functionalized Montmorillonite as a Heterogeneous Catalyst. *ChemCatChem* **2016**, *8*, 1–11.
- (277) Tambade, P. J.; Patil, Y. P.; Nandurkas, N. S.; Bhanage, B. M. Copper-Catalyzed, Palladium-Free Carbonylative Sonogashira Coupling Reaction of Aliphatic and Aromatic Alkynes with Iodoaryls. *Synlett* **2008**, 886–888.
- (278) Volla, C. M. R.; Bäckvall, J.-E. Palladium-Catalyzed Oxidative Domino Carbocyclization-Carbonylation-Alkynylation of Enallenes. *Org. Lett.* **2014**, *16*, 4174–4177.
- (279) Zhu, C.; Yang, B.; Bäckvall, J.-E. Highly Selective Cascade C–C Bond Formation via Palladium-Catalyzed Oxidative Carbonylation-Carbocyclization-Carbonylation-Alkynylation of Enallenes. *J. Am. Chem. Soc.* **2015**, *137*, 11868–11871.
- (280) Zhou, Q.-Q.; Guo, W.; Ding, W.; Wu, X.; Chen, X.; Lu, L.-Q.; Xiao, W.-J. Decarboxylative Alkynylation and Carbonylative Alkynylation of Carboxylic Acids Enabled by Visible-Light Photoredox Catalysis. *Angew. Chem., Int. Ed.* **2015**, *54*, 11196–11199.
- (281) Yuang, J.; Wang, J.M.; Zhang, G.; Liu, C.; Qi, X.; Lan, Y.; Miller, J. T.; Kropf, A. J.; Bunel, E. E.; Lei, A. Bimetallic Zinc Complex-Active Species in Coupling of Terminal

- Alkynes with Aldehydes *via* Nucleophilic Addition/Oppenauer Oxidation. *Chem. Commun.* **2015**, *51*, 576–579.
- (282) Qi, X.; Li, Y.; Zhang, G.; Li, Y.; Lei, A.; Liu, C.; Lau, Y. Dinuclear *versus* Mononuclear Pathways in Zinc Mediated Nucleophilic Addition: A Combined Experimental and DFT Study. *Dalton Trans.* **2015**, *44*, 1165–1171.
- (283) Tang, S.; Zeng, L.; Liu, Y.; Lei, A. Zinc-Catalyzed Dehydrogenative Cross-Coupling of Terminal Alkynes with Aldehydes: Access to Ynones. *Angew. Chem., Int. Ed.* **2015**, *54*, 15850–15853.
- (284) Ogiwara, Y.; Kubota, M.; Kurogi, K.; Konakahara, T.; Sakai, N. Oxidative Coupling of Terminal Alkynes with Aldehydes Leading to Alkynyl Ketones Using Indium(III) Bromide. *Chem. – Eur. J.* **2015**, *21*, 18598–18600.
- (285) Wang, Z.; Li, L.; Huang, Y. A General Synthesis of Ynones from Aldehydes *via* Oxidative C–C Bond Cleavage under Aerobic Conditions. *J. Am. Chem. Soc.* **2014**, *136*, 12233–12236.
- (286) Wang, Z.; Li, X.; Huang, Y. Direct α -Vinylidene of Aldehydes and Subsequent Cascade: Gold and Amine Catalysts Work Synergistically. *Angew. Chem., Int. Ed.* **2013**, *52*, 14219–14223.
- (287) Wang, H.; Xie, F.; Qi, Z.; Li, X. Iridium- and Rhodium-Catalyzed C–H Activation and Formal Alkynylation of Benzaldehydes under Chelation-Assistance. *Org. Lett.* **2015**, *17*, 920–923.
- (288) Ai, W.; Wu, X.; Tang, H.; Yang, X.; Li, X.; Zhou, B. Rh(III)- or Ir(III)-Catalyzed Ynone Synthesis from Aldehydes *via* Chelation-Assisted C–H Bond Activation. *Chem. Commun.* **2015**, *51*, 7871–7874.
- (289) Liu, X.; Yu, L.; Luo, M.; Zhu, J.; Wei, W. Radical-Induced Metal-Free Alkynylation of Aldehydes by Direct C–H Activation. *Chem. – Eur. J.* **2015**, *21*, 8745–8749.
- (290) Zhang, R.-Y.; Xi, L. Y.; Zhang, L.; Chen, S.-Y.; Yu, X. Q. Metal-Free Synthesis of Ynones *via* Direct C–H Alkynylation of Aldehydes with Ethynylbenziodoxalones. *Tetrahedron* **2015**, *71*, 6176–6182.
- (291) Ouyang, X.-Y.; Song, R.-J.; Wang, C.-Y.; Li, J.-H. Metal-Free Carbonyl C(sp²)-H Oxidative Alkynylation of Aldehydes using Hypervalent Iodine Reagents Leading to Ynones. *Chem. Commun.* **2015**, *51*, 14497–14500.
- (292) Sánchez-Obregón, R.; Ortiz, B.; Walls, F.; Yuste, F.; García-Ruano, J. L. Asymmetric Synthesis of α -Acetylenic Epoxides. *Tetrahedron: Asymmetry* **1999**, *10*, 947–955.
- (293) Rankin, T.; Tykwinski, R. R. Synthesis and Derivatization of Ethynyl α,α -Dibromomethyl Ketones: Formation of Highly Functionalized Vinyl Triflates. *Org. Lett.* **2003**, *5*, 213–216.
- (294) Ho, H. E.; James, M. J.; O'Brien, P.; Taylor, R, J. K.; Unsworth, W. P. Ag(I)-Catalyzed Synthesis of Azabicyclic Alkaloid Frameworks from Ketimine-Tethered Ynones: Total Synthesis of Indolizidine 209D. *Org. Lett.* **2018**, *20*, 1439–1443.

- (295) James, M. J.; Grant, N. D.; O'Brian, P.; Taylor, R. J. K.; Unsworth, W. P. Catalytic Dearomatization Approach to Quinomizidine Alkaloids: Five-Step Total Synthesis of (\pm)-Lasubine II. *Org. Lett.* **2016**, *18*, 6256–6259.
- (296) Plažuk, D.; Zakrgewski, J. Friedel-Crafts Acylation of Ferrocene with Alkynoic Acids. *J. Organomet. Chem.* **2009**, *694*, 1802–1806.
- (297) Flamhoic, R.; Plažuk, D.; Zakrgewski, J.; Métivier, R.; Nakatani, K.; Makai, A.; Wozuiak, K. A New Class of Pyrenyl Solid-State Emitters: 1-Pyrenyl Ynones. Synthesis via the Friedel-Crafts Route, Molecular and Electronic Structure and Photophysical Properties. *RSC Adv.* **2014**, *4*, 31594–31601.
- (298) Huang, H.; Zhang, G.; Chen, Y. Dual Hypervalent Iodine(III) Reagents and Photoredox Catalysis Enable Decarboxylative Ynylation under Mild Conditions. *Angew. Chem., Int. Ed.* **2015**, *54*, 7872–7876.
- (299) Tan, H.; Li, H.; Ji, W.; Wang, L. Sunlight-Driven Decarboxylative Alkynylation of α -Keto Acids with Bromoacetylenes by Hypervalent Iodine Reagent Catalysis: A Facile Approach to Ynones. *Angew. Chem., Int. Ed.* **2015**, *54*, 8374–8377.
- (300) Wang, H.; Guo, L.-N.; Wang, S.; Duan, X.-H. Decarboxylative Alkynylation of α -Keto Acids and Oxamic Acids in Aqueous Media. *Org. Lett.* **2015**, *17*, 3054–3057.
- (301) Wang, P.-F.; Feng, Y.-S.; Chen, Z.-F.; Wu, Q.-M.; Wang, G.-Y.; Liu, L.-L.; Dai, J.-J.; Xu, J.; Xu, H.-J. Transition-Metal-Free Synthesis of Ynones via Decarboxylative Alkynylation of α -Keto Acids under Mild Conditions. *J. Org. Chem.* **2015**, *80*, 9314–9320.
- (302) Yu, Y.; Yang, W.; Pflästerer, D.; Hashmi, A. S. K. Dehydrogenative Meyer–Schuster-Like Rearrangement: A Gold-Catalyzed Reaction Generating an Alkyne. *Angew. Chem., Int. Ed.* **2014**, *53*, 1144–1147.
- (303) Cadierno, V.; Crochet, P.; García-Carrido, S. E.; Gimeno, J. Metal-Catalyzed Transformations of Propargylic Alcohols into α,β -Unsaturated Carbonyl Compounds: From the Meyer-Schuster and Rupe Rearrangements to Redox Isomerization. *Dalton Trans.* **2010**, *39*, 4015–4031.
- (304) Gao, M.; Thorpe, S. B.; Kleeberg, C.; Sleboznick, C.; Marder, T. B.; Santos, W. L. Structure and Reactivity of a Preactivated sp^2 - sp^3 Diboron Reagent: Catalytic Regioselective Boration of α,β -Unsaturated Conjugated Compounds. *J. Org. Chem.* **2011**, *76*, 3997–4007.
- (305) Xie, J.B.; Lin, S.; Qiao, S.; Li, G. Asymmetric Catalytic Enantio- or Diastereoselective Boron Conjugate Addition Reactions of α -Functionalized α,β -Unsaturated Carbonyl Substrates. *Org. Lett.* **2016**, *18*, 3926–3929.
- (306) Mori, S.; Nakamura, E.; Morokuma, K. Mechanism of Addition of Organocuprates to Alkynyl Carbonyl Compounds. A Mechanistic Bridge between Carbocupration and Conjugate Addition. *Organometallics* **2004**, *23*, 1081–1088.
- (307) Marshall, J. A.; Andersen, M. W. Synthesis of Macrocyclic Propargylic Alcohols by Ene-Type Cyclization of Unsaturated Acetylenic Aldehydes. *J. Org. Chem.* **1992**, *57*, 2766–2768.

- (308) Shang, W.; Fairhurst, M. E.; Sydnes, L. K. Preparation of Silyl-Protected γ -Hydroxylated α,β -Unsaturated Acetylenic Ketones and Their Reactions with Some Nucleophiles. *Synth. Commun.* **2016**, *46*, 775–792.
- (309) Sydnes, L. K.; Holmelid, B.; Senge, M.; Hanstein, M. New Regiochemical Synthesis of Tri- and Tetrasubstituted Furans. *J. Org. Chem.* **2009**, *74*, 3430–3443.
- (310) Gridley, J. J.; Coogan, M. P.; Knight, D. W.; Malik, K. M. A.; Sharland, C. M.; Singkhonrat, J.; Williams, S. A Stereoselective Synthesis of *anti*- γ,δ -Alkynyl- and -Alkenyl- β -hydroxy- α -amino Esters from Tin(II) Enolates of Glycinate. *Chem. Commun.* **2003**, 2550–2551.
- (311) Capperucci, A.; Degl'Innocenti, A.; Dondoli, P.; Nocentini, T.; Reginato, G.; Ricci, A. Acetylenic Silyl Ketone as Polysynthetic Equivalent of Useful Building Blocks in Organic Synthesis. *Tetrahedron* **2001**, *57*, 6267–6276.
- (312) Marsden, A.; Thomas, E. J. An Approach to the Synthesis of Phomactins Using a Wittig Rearrangement. *ARKIVOC* **2002**, (ix), 78–92.
- (313) Marshall, J. A.; Andersen, M. W. Synthesis of Macrocyclic Propargylic Alcohols by Ene-Type Cyclization of Unsaturated Acetylenic Aldehydes. *J. Org. Chem.* **1992**, *57*, 2766–2768.
- (314) Marshall, J. A.; Crooks, S. L.; DeHoff, B. S. Cembranolide Total Synthesis. Macrocyclization of (α -Alkoxyallyl)stannane-Acetylenic Aldehydes as a Route to Cembrane Lactones. *J. Org. Chem.* **1988**, *53*, 1616–1623.
- (315) Ahlquist, M.; Nielsen, T. E.; Qument, S. L.; Tanner, D.; Norrby, P. O. An Experimental and Theoretical Study of the Mechanism of Stannylcupration of α,β -Acetylenic Ketones and Esters. *Chem. – Eur. J.* **2006**, *12*, 2866–2873.
- (316) Lu, B.-L.; Lu, J.-M.; Shi, M. LDA-Mediated Domino Carbolithiation Reactions of Vinylidenecyclopropanes with But-3-yn-2-one and 1-Phenylprop-2-yn-1-one. *Tetrahedron Lett.* **2010**, *51*, 321–324 (Corrigendum: *Tetrahedron Lett.* **2012**, *53*, 3940).
- (317) Hanzawa, Y.; Kakuuchi, A.; Yabe, M.; Narita, K.; Tabuchi, N.; Taguchi, T. Pd-Catalyzed Acylation of α,β -Ynone with Acylzirconocene Chloride and One-Pot Formation of Cyclopentenone Derivatives. *Tetrahedron Lett.* **2001**, *42*, 1737–1739.
- (318) Hanazawa, Y.; Tabuchi, N.; Narita, K.; Kakuuchi, A.; Yabe, M.; Taguchi, T. Pd-Catalyzed Regioselective Acylation of α,β -Unsaturated Ketone Derivatives by Acylzirconocene Chloride as an Acyl Group Donor. *Tetrahedron* **2002**, *58*, 7559–7571.
- (319) Arcadi, A.; Aschi, M.; Marinelli, F.; Verdecchia, M. Pd-Catalyzed Regioselective Hydroarylation of α -(2-Aminoaryl)- α,β -ynones with Organoboron Derivatives as a tool for the Synthesis of Quinolines: Experimental Evidence and Quantum-Chemical Calculations. *Tetrahedron* **2008**, *64*, 5354–5361.
- (320) Arai, T.; Suemitsu, Y.; Ikematsu, Y. Ni(0)-Catalyzed Conjugate Addition of Me₃SiCN to Ynone: α -Bromo- β -cyano Tetrasubstituted Enones. *Org. Lett.* **2009**, *11*, 333–335.
- (321) James, M. J.; Cuthbertson, J. D.; O'Brien, P.; Taylor, R. J. K.; Unsworth, W. P. Silver(I)- or Copper(II)-Mediated Dearomatization of Aromatic Ynone: Direct Access to Spirocyclic Scaffolds. *Angew. Chem., Int. Ed.* **2015**, *54*, 7640–7643.

- (322) Liddon, J. T. R.; James, M. J.; Clarke, A. K.; O'Brien, P.; Taylor, R. J. K.; Unsworth, W. P. Catalyst-Driven Scaffold Diversity: Selective Synthesis of Spirocycles, Carbazoles and Quinolines from Indolyl Ynones *Chem. – Eur. J.* **2016**, *22*, 8777–8780.
- (323) Clarke, A. K.; James, M. J.; O'Brien, P.; Taylor, R. J. K.; Unsworth, W. P. Silica-Supported Silver Nitrate as a Highly Active Dearomatizing Spirocyclization Catalyst: Synergistic Alkyne Activation by Silver Nanoparticles and Silica. *Angew. Chem., Int. Ed.* **2016**, *55*, 13798–13802.
- (324) Liddon, J. T. R.; Clarke, A. K.; Taylor, R. J. K.; Unsworth, W. P. Preparation and Reactions of Indoleninyl Halides: Scaffolds for the Synthesis of Spirocyclic Indole Derivatives. *Org. Lett.* **2016**, *18*, 6328–6331.
- (325) Clarke, A. K.; Lynam, J. M.; Taylor, R. J. K.; Unsworth, W. P. “Back-to-Front” Indole Synthesis using Silver(I) Catalysis: Unexpected C-3 Pyrrole Activation Mode Supported by DFT. *ACS Catal.* **2018**, *8*, 6844–6850.
- (326) Liddon, J. T. R.; Rossi-Ashton, J. A.; Clarke, A. K.; Lynam, J. M.; Taylor, R. J. K.; Unsworth, W. P. Divergent Reactivity of Indole-Tethered Ynones with Silver(I) and Gold(I) Catalysts: A Combined Synthestic and Computational Study. *Synthesis* **2018**, *50*, 4829–4836.
- (327) McGee, P.; Bellavance, G.; Korobkov, I.; Tarasewicz, A.; Barriault, L. Synthesis and Isolation of Organogold Complexes through a Controlled 1,2-Silyl Migration. *Chem. – Eur. J.* **2015**, *21*, 9662–9665.
- (328) Barabé, F.; Bétournay, G.; Bellavance, G.; Barriault, L. Gold-Catalyzed Synthesis of Carbon-Bridged Medium-Sized Rings. *Org. Lett.* **2009**, *11*, 4236–4238.
- (329) Sow, B.; Bellavance, G.; Barabé, F.; Barriault, L. One-pot Diels–Alder Cycloaddition/Gold(I)-Catalyzed 6-endo-dig Cyclization for the Synthesis of the Complex Bicyclo[3.3.1]alkenone Framework. *Beilstein J. Org. Chem.* **2011**, *7*, 1007–1013.
- (330) Bellavance, G.; Barriault, L. Total Syntheses of Hyperforin and Papuaforins A–C, and Formal Synthesis of Nemorosone through a Gold(I)-Catalyzed Carbocyclization. *Angew. Chem., Int. Ed.*, **2014**, *53*, 6701–6704.
- (331) Zhang, X.; Larock, R. C. Synthesis of Spiro[4.5]trienones by Intramolecular *ipso*-Halocyclization of 4-(*p*-Methoxyaryl)-1-alkynes. *J. Am. Chem. Soc.* **2005**, *127*, 12230–12231.
- (332) Lan, Q.; Wang, X.; Maruoka, K. Asymmetric Conjugate Additions of α -Substituted- α -cyanoacetates to Acetylenic Ketones by Chiral Phase Transfer Catalysis. *Tetrahedron Lett.* **2007**, *48*, 4575–4678.
- (333) Lan, Q.; Wang, X.; Shirakawa, S.; Maruoka, K. Phase-Transfer Catalyzed Asymmetric Conjugate Additions of β -Ketoesters to Acetylenic Ketones. *Org. Proc. Res. Dev.* **2010**, *14*, 684–686.
- (334) Zhou, Y.; Tao, X.; Yao, Q.; Zhao, Y.; Li, Y. Insertion of Isolated Alkynes into Carbon-Carbon σ -Bonds of Unstrained Cyclic β -Ketoesters via Transition-Metal-Free Tandem Reactions: Synthesis of Medium-Sized Ring Compounds. *Chem. – Eur. J.* **2016**, *22*, 17936–17939.

- (335) Sydnes, L. K.; Isanov, R.; Sengee, M.; Livi, F. Regioselective Synthesis of Tetra-Substituted Furans. *Synth. Commun.* **2013**, *43*, 2898–2905.
- (336) Bella, M.; Jørgensen, K. A. Organocatalytic Enantioselective Conjugate Addition to Alkynones. *J. Am. Chem. Soc.* **2004**, *126*, 5672–5673.
- (337) Ni, C.; Zhang, L.; Hu, J. Nucleophilic Fluoroalkylation of α,β -Enones, Alkynes, and Activated Alkynes with Fluorinated Sulfones: Probing the Hard/Soft Nature of Fluorinated Carbanions. *J. Org. Chem.* **2008**, *73*, 5699–5713.
- (338) Arcadi, A.; Bianchi, G.; Inesi, A.; Marinelli, F.; Rossi, L. Sequential Alkylation/Heterocyclization of β -(2-Aminophenyl)- α,β -ynones Promoted by Electrogenenerated Carbanions: A New Approach to Functionalized 4-Alkylquinolines. *Synlett* **2007**, 1031–1036.
- (339) Shiroodi, R. K.; Soltani, M.; Gevorgyan, V. Gold-Catalyzed 1,3-Transposition of Ynones. *J. Am. Chem. Soc.* **2014**, *136*, 9882–9885.
- (340) Ji, J.; Lin, L.; Tang, Q.; Kang, T.; Liu, X.; Feng, X. Highly Efficient Asymmetric Synthesis of Chiral γ -Alkenyl Butenolides Catalyzed by Chiral N,N' -Dioxide-Scandium(III) Complexes. *ACS Catal.* **2017**, *7*, 3763–3767.
- (341) Overhand, M.; Hecht, S. M. A Concise Synthesis of the Antifungal Agent (+)-Preussin. *J. Org. Chem.* **1994**, *59*, 4721–4722.
- (342) Spina, R.; Colacino, E.; Gabriele, B.; Salerno, G.; Martinez, J.; Lamaty, F. Preparation of Enantioenriched Iodinated Pyrrolidines by Iodocyclization of α -Amino-Ynones. *Org. Biomol. Chem.* **2012**, *10*, 9085–9089.
- (343) Spina, R.; Colacino, E.; Gabriele, B.; Salerno, G.; Martinez, J.; Lamaty, F. Synthesis of Pyrrolin-4-ones by Pt-Catalyzed Cycloisomerization in PEG under Microwaves. *J. Org. Chem.* **2013**, *78*, 2698–2702.
- (344) Miaskiewicz, S.; Weibel, J.-M.; Pale, P.; Blanc, A. Gold(I)-Catalyzed Cyclization/Nucleophilic Substitution of 1-(N -Sulfonylazetid-2-yl) Ynone into N -Sulfonylpyrrolin-4-ones. *Org. Lett.* **2016**, *18*, 844–847.
- (345) Mézailles, N.; Ricard, L.; Gagosz, F. Phosphine Gold(I) Bis-(trifluoromethanesulfonyl)imidate Complexes as New Highly Efficient and Air-Stable Catalysts for the Cycloisomerization of Enynes. *Org. Lett.* **2005**, *7*, 4133–4136.
- (346) Nguyen, K. H.; Tomasi, S.; Le Roch, M.; Toupet, L.; Renault, J.; Uriac, P.; Gouault, N. Gold-Mediated Synthesis and Functionalization of Chiral Halopyridones. *J. Org. Chem.* **2013**, *78*, 7809–7815.
- (347) Baldwin, J. E. Rules for Ring Closure. *J. Chem. Soc., Chem. Commun.* **1976**, 734–736.
- (348) Baldwin, J. E.; Thomas, R. C.; Kruse, L.; Silberman, L. Rules for Ring Closure: Ring Formation by Conjugate Addition of Oxygen Nucleophiles. *J. Org. Chem.* **1977**, *42*, 3846–3852.
- (349) Sengee, M.; Sydnes, L. K. Specific Conjugate Addition to α,β -Acetylenic Ketones. *Pure Appl. Chem.* **2011**, *83*, 587–596.
- (350) Sengee, M.; Sydnes, L. K. Michael Addition of Various Nitrogen and Oxygen Nucleophiles to 1,1-Diethoxy-3-yn-2-one. *Synthesis* **2011**, 3899–3907.

- (351) Hsu, D.-S.; Matsumoto, T.; Suzuki, K. Concise Synthesis of (\pm)- γ -Indomycinone. *Chem. Lett.* **2006**, *35*, 1016–1017.
- (352) Erdenebileg, U.; Høstmark, I.; Polden, K.; Sydnnes, L. K. Synthesis and Reactivity of 4-Amino-Substituted Furfurals. *J. Org. Chem.* **2014**, *79*, 1213–1221.
- (353) Li, H.; Xu, X.; Yang, J.; Xie, X.; Huang, H.; Li, Y. Iron-Catalyzed Cascade Reaction of Ynone with *o*-Aminoaryl Compounds: A Michael Addition-Cyclization Approach to 3-Carbonyl Quinolines. *Tetrahedron Lett.* **2011**, *52*, 530–533.
- (354) Reyes-Sanchez, A.; Garcia-Ventura, I.; Garcia, J. J. Easily Available Nickel Complexes as Catalysts for the Intermolecular Hydroamination of Alkenes and Alkynes. *Dalton Trans.* **2014**, *43*, 1762–1768.
- (355) Davydova, M. P.; Vasilevsky, S. F.; Nenajdenko, V. G. Reaction of Trifluoroacetyl Acetylenes with β -Amino Alcohols. Synthesis of Enaminoketones and Unusual Fragmentation. *J. Fluor. Chem.* **2016**, *190*, 61–67.
- (356) Chrisholm, D. R.; Valentine, R.; Pohl, E.; Whiting, A. Conjugate Addition of 3-Butyn-2-one to Anilines in Ethanol: Alkene Geometric Insights through in situ FTIR Monitoring. *J. Org. Chem.* **2016**, *81*, 7557–7565.
- (357) Peng, H.; Li, J.; Wang, F.; Liu, B.; Yin, B. Synthesis of Spiro-Lactams and Polysubstituted Pyrroles via Ceric Ammonium Nitrate-Mediated Oxidative Cyclization of *N*-Furan-2-ylmethyl- β -enaminones. *J. Org. Chem.* **2016**, *81*, 4939–4946.
- (358) Sazonov, P. K.; Stolyarenko, V. Y.; Shtern, M. M.; Beletskaya, I. P. Unexpected Lanthanide Cation Selectivity of Bis- β -ketovinylated Diaza-18-crown-6 and Open Diamines: Cooperative Effect of the Second Keto Group. *J. Incl. Phenom. Macrocycl. Chem.* **2014**, *79*, 193–203.
- (359) Zou, J.; Zeng, G.; Yang, R.; Yin, B. Synthesis of Polyfunctionalized Pyrroles from Furfurylamines and Ynones via CuCl_2 -Catalyzed and Iodine-Mediated Oxidative Annulation of *N*-Furfuryl- β -enaminones. *Synthesis* **2017**, *49*, 2241–2249.
- (360) Karpov, A. S.; Rominger, F.; Müller, T. J. J. A Diversity Oriented Four-Component Approach to Tetrahydro- β -carbolines Initiated by Sonogashira Coupling. *Org. Biomol. Chem.* **2005**, *3*, 4382–4391.
- (361) Bernini, R.; Cacchi, S.; Fabrizi, G.; Filisti, E.; Sferrazza, A. Polysubstituted Quinolines from 2-Alkynylanilines and α,β -Ynones through a Sequential Conjugate Addition- Cyclization Process. *Synlett* **2009**, 1245–1250.
- (362) Jie, J.; Li, H.; Piao, M.; Yang, X. Efficient One-pot Synthesis of Benzo[*e*]pyrazolo[1,5-*c*]thiazine Derivatives under Copper-Catalyzed Conditions. *Heterocycles* **2016**, *92*, 1215–1223.
- (363) Rossi, E.; Abbiati, G.; Canevari, V.; Nava, D.; Arcadi, A. Divergent Sequential Reactions of β -(2-Aminophenyl)- α,β -ynones with Nitrogen Nucleophiles. *Tetrahedron* **2004**, *60*, 11391–11398.
- (364) Shen, J.; Cheng, G.; Cui, X. “One Pot” Regiospecific Synthesis of Polysubstituted Pyrroles from Benzylamines and Ynones under Metal Free Conditions. *Chem. Commun.* **2013**, *49*, 10641–10643.

- (365) Shen, J.; Cai, D.; Kuai, C.; Liu, Y.; Wei, M.; Cheng, G.; Cui, X. Base-Promoted β -C(sp³)-H Functionalization of Enaminones: An Approach to Polysubstituted Pyridines. *J. Org. Chem.* **2015**, *80*, 6584–6589.
- (366) Vasilevsky, S. F.; Davydova, M. P.; Mamatuyk, V. I.; Pleshkova, N. V.; Fadeev, D. S.; Alabugin, I. V. Reaction of α,β -Alkynylketones with β -Amino Alcohols: Pseudoephedrine-assisted Cleavage of Triple Bond *via* Formal Internal Redox Process. *Mendeleev Commun.* **2015**, *25*, 377–379.
- (367) Gao, D.; Back, T. G. Indole Synthesis by Conjugate Addition of Anilines to Activated Acetylenes and an Unusual Ligand-Free Copper(II)-Mediated Intramolecular Cross-Coupling. *Chem. – Eur. J.* **2012**, *18*, 14828–14840.
- (368) Cui, H.-L.; Peng, L.-J.; Zhou, H.-L.; You, X.-L.; Jiang, X.-J. Stereoselective Synthesis of Enamino Ketones Through an Aza-Michael/Hydrolysis Cascade Reaction. *Org. Biomol. Chem.* **2017**, *15*, 5121–5125.
- (369) Gao, D.; Parvez, M.; Back, T. G. Synthesis of Indoles by Conjugate Addition and Ligand-Free Copper-Catalyzed Intramolecular Arylation of Activated Acetylenes with *o*-Haloanilines. *Chem. – Eur. J.* **2010**, *16*, 14281–14284.
- (370) Liu, J.; Wei, W.; Zhao, T.; Liu, X.; Wu, J.; Yu, W.; Chang, J. Iodine/Copper Iodide-Mediated C-H Functionalization: Synthesis of Imidazo[1,2-*a*]pyridines and Indoles from *N*-Aryl Enamines. *J. Org. Chem.* **2016**, *81*, 9326–9336.
- (371) Cui, H.-L.; Wang, J.-F.; Zhou, H.-L.; You, X.-L.; Jiang, X.-J. Catalyst-Free Synthesis of Novel Dimeric β -Carboline Derivatives *via* an Unexpected [2 + 2 + 2] Annulation. *Org. Biomol. Chem.* **2017**, *15*, 3860–3862.
- (372) Cao, Z.; Xhu, H.; Meng, X.; Guan, J.; Zhang, Q.; Tian, L.; Sun, X.; Chen, G.; You, J. Metal-Free Reaction of *ortho*-Carbonylated Alkynyl-Substituted Arylaldehydes with Common Amines: Selective Access to Functionalized Isoindolinone and Indenamine Derivatives. *Chem. – Eur. J.* **2016**, *22*, 16975–16985.
- (373) Fricero, P.; Bialy, L.; Brown, A. W.; Czechtizky, W.; Méndez, M.; Harrity, J. P. A. Synthesis and Modular Reactivity of Pyrazole 5-Trifluoroborates: Intermediates for the Preparation of Fully Functionalized Pyrazoles. *J. Org. Chem.* **2017**, *82*, 1688–96.
- (374) Nes, I.; Sydnes, L. K. Formation of *N*-Heterocycles from 1,1-Diethoxy-5-hydroxyalk-3-yn-2-ones. *Synthesis* **2015**, *47*, 89–94.
- (375) Li, S.; Li, Z.; Peng, D.; Li, Y.; Zhu, J.; Xie, H.; Yuan, Y.; Chen, Z.; Wu, Y. Au(I)-Catalyzed Synthesis of 5-Bromodifluoromethyl Pyrazoles from Fluorinated Alkynyl Ketones and Hydrazine. *Chin. J. Chem.* **2011**, *29*, 2695–2701.
- (376) Muzalevskiy, V. M.; Rulev, A. Y.; Romanov, A. R.; Kondrashov, E. V.; Ushakov, I. A.; Chertkov, V. A.; Nenajdenko, V. G. Selective, Metal-Free Approach to 3- or 5-CF₃-Pyrazoles: Solvent Switchable Reaction of CF₃-Ynones with Hydrazines. *J. Org. Chem.* **2017**, *82*, 7200–7014.
- (377) Hsieh, M.-T.; Kuo, S.-C.; Lin, H.-C. Solvent- and Transition Metal Catalyst-Dependent Regioselectivity in the [3+2] Cyclocondensation of Trifluoromethyl- α,β -ynones with Hydrazines: Switchable Access to 3- and 5-Trifluoromethylpyrazoles. *Adv. Synth. Catal.* **2015**, *357*, 683–689.

- (378) Ji, G.; Wang, X.; Zhang, S.; Xu, Y.; Ye, Y.; Li, M.; Zhang, Y.; Wang, J. Synthesis of 3-Trifluoromethylpyrazoles via Trifluoromethylation/Cyclization of α,β -Alkynic Hydrazones Using a Hypervalent Iodine Reagent. *Chem. Commun.* **2014**, *50*, 4361–4363.
- (379) Martins, M. A. P.; Emmerich, D. J.; Pereira, C. M. P.; Cunico, W.; Rossato, M.; Zanatta, N.; Bonaccorso, H. G. Synthesis of New Halo-Containing Acetylenes and Their Application to the Synthesis of Azoles. *Tetrahedron Lett.* **2004**, *45*, 4935–4938.
- (380) Dastrup, D. M.; Yap, A. H.; Weinreb, S. M.; Henry, J. R.; Lechleiter, A. J. Synthesis of β -Tosylkethylhydrazine and Its Use in Preparation of *N*-Protected Pyrazoles and 5-Aminopyrazoles. *Tetrahedron* **2004**, *60*, 901–906.
- (381) Ilangovan, A.; Sakthivel, P.; Zipse, H. An Unusual Grob-type C-C/C-O Bond Cleavage of 5-Acyl-2,3-dihydro-4*H*-Pyran-4-one Derivatives. *ChemistrySelect* **2016**, *5*, 1109–1116.
- (382) Chapman, A. V.; Cook, M. J.; Katritzky, A. R.; Abraham, M. H.; Danil de Namor, A. F.; Dumont, L.; Reisse, J. Aromaticity and Tautomerism—VII: Empirical Resonance Energy and Conjugation Energy of Pyrazole and Isoxazole from Heats of Dehydration Data. *Tetrahedron* **1978**, *34*, 1571–1575.
- (383) Xie, M.; Li, M.; Liu, C.; Zhang, J.; Feng, C. Facile Regioselective Synthesis of 5-Hydroxy-4,5-dihydroisoxazoles from Acetylenic Ketones. *J. Heterocyclic Chem.* **2012**, *49*, 1462–1465.
- (384) Senica, L.; Petek, N.; Groselj, U.; Svete, J. A Four-step Synthesis of Novel (*S*)-1-(Heteroaryl)-1-aminoethanes from (*S*)-Boc-alanine. *Acta Chim. Slov.* **2015**, *62*, 60–71.
- (385) Karpov, A. S.; Merkul, E.; Rominger, F.; Müller, T. J. J. Concise Syntheses of Meridianins by Carbonylative Alkynylation and a Four-Component Pyrimidine Synthesis. *Angew. Chem., Int. Ed.* **2005**, *44*, 6959–6956.
- (386) Shen, J.; Wang, X.; Lin, X.; Yang, Z.; Cheng, G.; Cui, X. One-Pot Regiospecific Synthesis of Quinoxalines via a CH₂-Extrusion Reaction. *Org. Lett.* **2016**, *18*, 1378–1381.
- (387) Young, J.; Schäfer, C.; Solan, A.; Baldrice, A.; Belcher, M.; Nisanci, B.; Wheeler, K. A.; Trivedi, E. R.; Török, B.; Dembinski, R. Regioselective “Hydroamination” of Alk-3-ynones with Non-Symmetrical *o*-Phenylenediamines. Synthesis of Diversely Substituted 3*H*-1,5-Benzodiazepines via (*Z*)-3-Amino-2-alkenones. *RSC Adv.* **2016**, *6*, 107081–107093.
- (388) Roy, S.; Davydova, M. P.; Pal, R.; Gilmore, K.; Tolstikov, G. A.; Vasilevsky, S. F.; Alabugin, I. V. Dissecting Alkynes: Full Cleavage of Polarized CC Moiety via Sequential Bis-Michael Addition/Retro-Mannich Cascade. *J. Org. Chem.* **2011**, *76*, 7482–7490.
- (389) Yang, X.; Cheng, G.; Shen, J.; Kuai, C.; Cui, X. Cleavage of the C-C Triple Bond of Ketoalkynes: Synthesis of 4(3*H*)-Quinazolines. *Org. Chem. Front.* **2015**, *2*, 366–368.
- (390) Sharma, G. V. M.; Srikanth, G.; Reddy, P. P. Stereospecific Total Synthesis of Dinemasone A by Double Intramolecular Hetero-Michael Addition (DIHMA). *Org. Biomol. Chem.* **2012**, *10*, 4562–4570.
- (391) Yoshida, M.; Fujino, Y.; Doi, T. Synthesis of γ -Benzopyranone by TfOH-Promoted Regioselective Cyclization of *o*-Alkynoyl Phenols. *Org. Lett.* **2011**, *13*, 4526–4529.

- (392) Kataoka, T.; Kinoshita, H.; Kinoshita, S.; Iwamura, T. Tandem Michael-Aldol Reaction via 6-*endo-dig* Cyclization of Ynone-Chalcogenides: Synthesis of 2-Unsubstituted 3-(Hydroxyalkyl)chalcogenochromen-4-ones. *Tetrahedron Lett.* **2002**, *43*, 7039–7041.
- (393) Mendoza, A.; Pardo, P.; Rodriguez, F.; Fañanas, F. J. Synthesis of [3.3.1] Bicyclic Compounds by a Brønsted Acid Catalysed Double Intramolecular Michael Addition. *Chem. – Eur. J.* **2010**, *16*, 9758–9762.
- (394) Isanov, R.; Holmelid, B.; Törnroos, K. W.; Sydnes, L. K. Synthesis of (*E*)-1,1-Diethoxy-3-(3-hydroxy-3-arylfuro[2,3-*b*]quinoxalin-2(3*H*)-ylidene)propan-2-ones via Acid-Catalyzed, Stereoselective 5-*exo-dig* Cyclization. *J. Heterocycl. Chem.* **2015**, *52*, 711–718.
- (395) Tiwari, K. N.; Monserrat, J.-P.; de Montigny, F.; Jaoen, G.; Rager, M.-N.; Hillard, E. Synthesis and Structural Characterization of Ferrocenyl-Substituted Aurones, Flavones, and Flavonols. *Organometallics* **2011**, *30*, 5424–5432.
- (396) Yamamoto, A.; Ueda, A.; Brémond, P.; Tiseni, P. S.; Kishi, Y. Total Synthesis of Halichondrin C. *J. Am. Chem. Soc.* **2012**, *134*, 893–896.
- (397) Liang, L.; Li, E.; Dong, X.; Huang, Y. DABCO-Mediated [4+4]-Domino Annulation: Access to Functionalized Eight-Membered Cyclic Ethers. *Org. Lett.* **2015**, *17*, 4914–4917.
- (398) Deng, G.; Wang, F.; Lu, S.; Cheng, B. Synthesis of Pyrano[3,2-*c*]pyrazol-7(1*H*)-one Derivatives by Tandem Cyclization of 2-Diazo-3,5-dioxo-6-ynoates (Ynones). *Org. Lett.* **2015**, *17*, 4651–4653.
- (399) Axelrod, A.; Eliassen, A. M.; Chin, M. R.; Zlotkowski, K.; Siegel, D. Syntheses of Xanthofulvin and Vinaxanthone, Natural Products Enabling Spinal Cord Regeneration. *Angew. Chem., Int. Ed.* **2013**, *52*, 3421–3424.
- (400) Aoki, M.; Itezono, Y.; Shirai, H.; Nakayama, N.; Sakai, A.; Tanaka, Y.; Yamaguchi, A.; Simma, N.; Yokose, K.; Seto, H. Structure of a Novel Phospholipase T Inhibitor, Vinaxanthone (Ro 09-1450), Produced by *Penicillium Vinacem*. *Tetrahedron Lett.* **1991**, *32*, 4737–4740.
- (401) Shi, S.-L.; Kanai, M.; Shibasaki, M. Asymmetric Synthesis of Dihydropyranones from Ynones by Sequential Copper(I)-Catalyzed Direct Aldol and Silver(I)-Catalyzed Oxy-Michael Reactions. *Angew. Chem., Int. Ed.* **2012**, *51*, 3932–3935.
- (402) Wang, F.; Lu, S.; Chen, B.; Zhou, Y.; Yang, Y.; Deng, G. Regioselective Reversal in the Cyclization of 2-Diazo-3,5-dioxo-6-ynoates (Ynones, Ynamide): Construction of γ -Pyrones and 3(2*H*)-Furanones Starting from Identical Materials. *Org. Lett.* **2016**, *18*, 6248–6251.
- (403) Schuler, M.; Silva, F.; Bobbio, C.; Tessier, A.; Gouverneur, V. Gold(I)-Catalyzed Alkoxyhalogenation of β -Hydroxy- α,α -Difluoroynones. *Angew. Chem., Int. Ed.* **2008**, *47*, 7927–7930.
- (404) Silva, F.; Reiter, M.; Mills-Webb, R.; Sawicki, M.; Klär, D.; Bensel, N.; Wagner, A.; Gouverneur, V. Pd(II)-Catalyzed Cascade Wacker-Heck Reaction: Chemoselective Coupling of Two Electron-Deficient Reactants. *J. Org. Chem.* **2006**, *71*, 8390–8394.

- (405) Huang, W.-Y.; Nishikawa, T.; Nakazaki, A. Palladium-Catalyzed Cascade Wacker/Allylation Sequence with Allylic Alcohols Leading to Allylated Dihydropyrones. *ACS Omega* **2017**, *2*, 487–495.
- (406) Preindl, J.; Jouvin, K.; Laurich, D.; Seidel, G.; Fürstner, A. Gold- and Silver-Catalyzed Synthesis of Pyrones and Pyridine Derivatives: Mechanistic and Synthetic Aspects. *Chem. – Eur. J.* **2016**, *22*, 237–247.
- (407) Phillips, E. M.; Riedrich, M.; Scheidt, K. A. *N*-Heterocyclic Carbene-Catalyzed Conjugate Additions of Alcohols. *J. Am. Chem. Soc.* **2010**, *132*, 13179–13181.
- (408) Meng, X.; Zhu, H.; Chen, G.; Tian, L.; Sun, X.; Cao, Z.; You, J. Domino Reaction of *ortho*-Carbonylated Alkyne-Substituted Arylaldehydes with Arylsulfinic Acids: Efficient Access to Sulfonyl-Functionalized Indanones. *Asian J. Org. Chem.* **2017**, *6*, 921–926.
- (409) Trost, B. M.; Ball, Zachary T. Addition of Metalloid Hydrides to Alkynes: Hydrometallation with Boron, Silicon, and Tin. *Synthesis* **2005**, 853–887.
- (410) Rooke, D. A.; Ferreira, E. M. Stereoselective Synthesis of Trisubstituted Olefins via Palladium Catalysis: α -Silylenones with Geometrical Complementarity. *J. Am. Chem. Soc.* **2010**, *132*, 11926–11928.
- (411) Trost, B. M.; Ball, Z. T. Synthetic Stitching with Silicon: Geminal Alkylation-Hydroxylation of Alkynyl Carbonyl Compounds. *J. Am. Chem. Soc.* **2004**, *126*, 13942–13944.
- (412) Trost, B. M.; Bertogg, A. Si-Based Benzylic 1,4-Rearrangement/Cyclization Reaction. *Org. Lett.* **2009**, *11*, 511–513.
- (413) Linstadt, R. T. H.; Peterson, C. A.; Lippincott, D. J.; Jette, C. J.; Lipshutz, B. H. Stereoselective Silylcupration of Conjugated Alkynes in Water at Room Temperature. *Angew. Chem., Int. Ed.* **2014**, *53*, 4159–4163.
- (414) Valdernes, S.; Apeland, I.; Flemmen, G.; Sydnnes, L. K. Toward the Synthesis of Modified Carbohydrates by Conjugate Addition of Propane-1,3-dithiol to α,β -Unsaturated Ketones. *Helv. Chim. Acta* **2012**, *95*, 2099–2122.
- (415) Ranu, B. C.; Banerjee, S.; Jana, R. Ionic Liquid as Catalyst and Solvent: The Remarkable Effect of a Basic Ionic Liquid, [bmIm]OH on Michael Addition and Alkylation of Active Methylene Compounds. *Tetrahedron* **2007**, *63*, 776–782.
- (416) Xu, C.; Berley, J. K.; Enache, D. I.; Knight, D. W.; Lunn, M.; Lok, M.; Hutchings, G. J. On the Synthesis of β -Keto-1,3-dithianes from Conjugated Ynones Catalyzed by Magnesium Oxide. *Tetrahedron Lett.* **2008**, *49*, 2454–2456.
- (417) de Lima Borges, E.; Nobre, P. C.; da Silva, M. S.; Jacob, R. G.; Lenardão, E. J.; Perin, G. J. PEG-400 as a Recyclable Solvent in the Synthesis of β -Arylthio- α,β -unsaturated Esters, Ketone and Aldehyde under Base and Catalyst-Free Conditions. *Environ. Chem. Engineer.* **2016**, *4*, 2004–2007.
- (418) Zheng, X.-L.; Xu, X.-L.; Zhang, Y.-M. Stereoselective Michael Addition and Michael-Aldol Tandem Reaction of Diorganyl Diselenides or Disulfides with Conjugated Alkynones Mediated by Samarium Diiodide. *Chin. J. Chem.* **2004**, *22*, 958–965.

- (419) Civit, M. G.; Sanz, X.; Vogels, C. M.; Bo, C.; Westcott, S. A.; Fernández, E. Ynones Merge Activation/Conjugate Addition of Chalcogenoborates ArE-Bpin (E = Se, S). *Adv. Synth. Catal.* **2015**, *357*, 3098–3103.
- (420) Shimada, K.; Moro-oka, A.; Maruyama, A.; Fujisawa, H.; Saito, T.; Kawamura, R.; Kogawa, H.; Sakuraba, M.; Takata, Y.; Aoyagi, S.; Takikawa, Y.; Kabuto, C. Synthesis of Isochalcogenazole Rings by Treating β -(*N,N*)-Dimethylcarbamoylchalcogenenyl)alkenyl Ketones with Hydroxylamine-*O*-sulfonic Acid. *Bull. Chem. Soc. Jpn.* **2007**, *80*, 567–577.
- (421) Arcadi, A.; Chiarini, M.; Marinelli, F.; Picchini, S. A Concise One-Pot Approach to the Synthesis of 4-(1*H*-Indol-3-yl)quinolines. *Synthesis* **2011**, 4084–4090.
- (422) Wei, H.-X.; Kim, S. H.; Caputo, T. D.; Purkiss, D. W.; Li, G. Highly Stereoselective α -Hydroxylation/Chlorination of α,β -Acetylenic Ketones-An Efficient Approach to β -Halogeno Baylis-Hillman Adducts. *Tetrahedron* **2000**, *56*, 2397–2401.
- (423) Kataoka, T.; Kinoshita, H.; Kinoshita, S.; Iwamura, T.; Watanabe, S. A Convenient Synthesis of α -Halomethylene Aldols or β -Halo- α -(hydroxyalkyl)acrylates Using the Chalcogeno-Baylis-Hillman Reaction. *Angew. Chem., Int. Ed.* **2000**, *39*, 2358–2360.
- (424) Kinoshita, S.; Kinoshita, H.; Iwamura, T.; Watanabe, S.; Kataoka, T. Chalcogenide-Lewis Acid Mediated Reactions of Electron-Deficient Alkynes with Aldehydes. *Chem. – Eur. J.* **2003**, *9*, 1496–502.
- (425) Ohmaru, Y.; Sato, N.; Mizutani, M.; Kotani, S.; Sugiura, M.; Nakajima, M. Synthesis of Aryl Group-Modified DIOP Dioxides (Ar-DIOPs) and Their Application as Modular Lewis Base Catalysis. *Org. Biomol. Chem.* **2012**, *10*, 4562–4570.
- (426) Doderio, V. I.; Koll, L. C.; Faraoni, M. B.; Mitchell, T. N.; Podesta, J. C. Stereoselective Synthesis of Stannyl Enones via Palladium-Catalyzed and Free Radical Hydrostannation of Alkynyl Ketones with Trineophyltin Hydride. *J. Org. Chem.* **2003**, *68*, 10087–10091.
- (427) Pan, X.-Q.; Zou, J.-P.; Zhang, G.-L.; Zhang, W. Manganese(III)-Mediated Direct Phosonation of Arylalkenes and Arylalkynes. *Chem. Commun.* **2010**, *46*, 1721–1723.
- (428) Nguyen, V. H.; Nishino, H.; Kajikawa, S.; Kurosawa, K. Mn(III)-Based Reactions of Alkenes and Alkynes with Thiols. An Approach toward Substituted 2,3-Dihydro-1,4-oxathians and Simple Route to (*E*)-Vinyl Sulfides. *Tetrahedron* **1998**, *54*, 11445–11460.
- (429) Zhou, J.; Zhang, G.-L.; Zou, J.-P.; Zhang, W. Synthesis of Phosphonylated and Thiolated Indenones by Manganese(III)-Mediated Addition of Phosphorous- and Sulfur-Centered Radicals to 1,3-Diarylpropynes. *Eur. J. Org. Chem.* **2011**, 3412–3415.
- (430) Wen, J.; Shi, W.; Zhang, F.; Liu, D.; Tang, S.; Wang, H.; Lin, X.-M.; Lei, A. Electrooxidative Tandem Cyclization of Activated Alkynes with Sulfinic Acids to Access Sulfonated Indenones. *Org. Lett.* **2017**, *19*, 3131–3134.
- (431) Pan, C.; Huang, B.; Hu, W.; Feng, X.; Yu, J.-T. Metal-Free Radical Oxidative Annulation of Ynones with Alkanes to Access Indenones. *J. Org. Chem.* **2016**, *81*, 2087–2093.
- (432) Maekawa, H.; Takano, A.; Watanabe, M. Facile Synthesis of Multifunctionalized Allenes by Magnesium-Promoted Reductive Silylation of Aromatic Conjugated Ynones. *Tetrahedron Lett.* **2014**, *55*, 6208–6211.

- (433) Liou, K.-F.; Cheng, C.-H. Phosphine-Mediated [2+2] Cycloaddition of Internal Alk-2-ynoate and Alk-2-ynone to [60]Fullerene. *J. Chem. Soc., Chem. Commun.* **1995**, 2473–2474.
- (434) Rossi, E.; Abbiati, G.; Arcadi, A.; Marinelli, F. Concise Synthesis of Fused Polycyclic Quinolines. *Tetrahedron Lett.* **2001**, *42*, 3705–3708.
- (435) Iwata, S.; Hamura, T.; Suzuki, K. Siloxy(trialkoxy)ethene Undergoes Regioselective [2+2] Cycloaddition to Ynones and Ynoates *en route* to Functionalized Cyclobutenediones. *Chem. Commun.* **2010**, *46*, 5316–5318.
- (436) Yang, J.; Zhang, W.; Zhang, G.; Gao, Z. Reactivity of 1,3-Ynone in Transformation of Ru₂-Ru₄ Clusters: Formation of Ruthenoles via Tetraruthenium Intermediate. *J. Organomet. Chem.* **2015**, *799–800*, 166–172.
- (437) Hashimoto, T.; Maruoka, K. Recent Advances of Catalytic Asymmetric 1,3-Dipolar Cycloadditions. *Chem. Rev.* **2015**, *115*, 5366–5412.
- (438) Singh, M. S.; Chowdhury, S.; Koley, S. Progress in 1,3-Dipolar Cycloadditions in the Recent Decade: An Update to Strategic Development Toward the Arsenal of Organic Synthesis. *Tetrahedron* **2016**, *72*, 1603–1716.
- (439) Rostovtsev, V. V.; Green, L. G.; Fokin, V. V.; Sharpless, K. B. A Stepwise Huisgen Cycloaddition Process: Copper(I)-Catalyzed Regioselective “Ligation” of Azides and Terminal Alkynes. *Angew. Chem., Int. Ed.* **2002**, *41*, 2596–2599.
- (440) Tornøe, C. W.; Christensen, C.; Meldal, M. Peptidotriazoles on Solid Phase: [1,2,3]-Triazoles by Regioselective Copper(I)-Catalyzed 1,3-Dipolar Cycloadditions of Terminal Alkynes to Azides. *J. Org. Chem.* **2002**, *67*, 3057–3064.
- (441) Friscart, F.; Boons, G.-J. One-Pot Three-Step Synthesis of 1,2,3-triazoles by Copper-Catalyzed Cycloaddition of Azides with Alkynes Formed by a Sonogashira Cross-Coupling and Desilylation. *Org. Lett.* **2010**, *12*, 4936–4939.
- (442) Li, N.; Wang, D.; Li, J.; Shi, W.; Li, C.; Chen, B. One-Pot Synthesis of 4,5-Disubstituted 1,2,3-(NH)-Triazoles Using Terminal Acetylenes, Carbon Monoxide, Aryl Iodides and Sodium Azide. *Tetrahedron Lett.* **2011**, *52*, 980–982.
- (443) Hwang, S.; Bae, H.; Kim, S.; Kim, S. An Efficient High-Yielding One-Pot Synthesis of 4-Acyl-1,2,3-triazoles via Triisopropylsilyl-Protected Ynones. *Tetrahedron* **2012**, *68*, 1460–1465.
- (444) Farooq, T.; Haug, B. E.; Sydnes, L. K.; Törnroos, K. W. 1,3-Dipolar Cycloaddition of Benzyl Azide to Two Highly Functionalized Alkynes. *Monatsh. Chem.* **2012**, *143*, 505–512.
- (445) Cai, X.; Wang, C.; Sun, J. Organocatalytic Enantioselective Dipolar [3+2] Cycloaddition of Acetylenic Aldehydes with Nitrones for the Formation of Chiral 4-Isoxazolines. *Adv. Synth. Catal.* **2012**, *354*, 359–363.
- (446) Alemán, J.; Fraile, A.; Marzo, L.; García Ruano, J. L.; Izquierdo, C.; Díaz-Tendero, S. Enantioselective Synthesis of 4-Isoxazolines by 1,3-Dipolar Cycloadditions of Nitrones to Alkynals Catalyzed by Fluorodiphenylmethylpyrrolidines. *Adv. Synth. Catal.* **2012**, *354*, 1665–1671.
- (447) Nájera, C.; Sansano, J. M.; Yus, M. 1,3-Dipolar Cycloadditions of Azomethine Imines. *Org. Biomol. Chem.* **2015**, *13*, 8596–8636.

- (448) Pušavec, E.; Mirnik, J.; Šenica, L.; Grošelj, U.; Stanovnik, B.; Svete, J. Cu(I)-Catalyzed [3+2] Cycloadditions of *tert*-Butyl (*S*)-(3-Oxopent-4-yn-2-yl)carbamate to 1-Benzylidenepyrazole-3-one-Derived Azomethine Imines. *Z. Naturforsch.* **2014**, *69*, 615–626.
- (449) Pušavec Kirar, E.; Grošelj, U.; Mirri, G.; Požan, F.; Strle, G.; Štefane, B.; Jovanovski, V.; Svete, J. “Click” Chemistry Application of Copper Metal in Cu-Catalyzed Azomethine Imine–Alkyne Cycloadditions. *J. Org. Chem.* **2016**, *81*, 5988–5997.
- (450) Mirnik, J.; Pušavec Kirar, E.; Ričko, S.; Grošelj, U.; Golobič, A.; Požgan, F.; Štefane, B.; Svete, J. Cu⁰-Catalyzed 1,3-Dipolar Cycloadditions of α -Amino Acid Derived N,N-Cyclic Azomethine Imines to Ynones. *Tetrahedron* **2017**, *73*, 3329–3337.
- (451) Liang, L.; Huang, Y. Phosphine-Catalyzed [3+3]-Domino Cycloaddition of Ynones and Azomethine Imines to Construct Functionalized Hydropyridazine Derivatives. *Org. Lett.* **2016**, *18*, 2604–2607.
- (452) Bdiri, B.; Zhao, B.-J.; Zhou, Z.-M. Recent Advances in the Enantioselective 1,3-Dipolar Cycloadditions of Azomethine Ylides and Dipolarophiles. *Tetrahedron: Asymmetry* **2017**, *28*, 876–899.
- (453) Georgescu, E.; Caira, M.; Georgescu, F.; Drăghici, B.; Popa, M.M.; Dumitrascu, F. One-Pot Three-Component Synthesis of a Library of New Pyrrolo[1,2a]quinoline Derivatives. *Synlett* **2009**, 1795–1799.
- (454) Brioché, J.; Meyer, C.; Cossy, J. Synthesis of 2-Aminoindolizidines by 1,3-Dipolar Cycloaddition of Pyridinium Ylides with Electron-Deficient Ynamides. *Org. Lett.* **2015**, *17*, 2800–2803.
- (455) Rotaru, A. V.; Druta, I. D.; Oeser, T.; Müller, T. J. J. A Novel Coupling 1,3-Dipolar Cycloaddition Sequence as a Three-Component Approach to Highly Fluorescent Indolizines. *Helv. Chim. Acta.* **2005**, *88*, 1798–1812.
- (456) Yavari, I.; Sheykahmadi, J.; Naeimabadi, M.; Halvagar, M. R. Iodine-Mediated sp³ C–H Functionalization of Methyl Ketones; A One-Pot Synthesis of Functionalized Indolizines via the 1,3-Dipolar Cycloaddition Reaction between Pyridinium Ylides and Ynones. *Mol. Divers.* **2017**, *21*, 1–8.
- (457) Shi, F.; Luo, S.-W.; Tao, Z.-L.; He, L.; Yu, J.; Tu, S.-J.; Gong, L.-Z. The Catalytic Asymmetric 1,3-Dipolar Cycloaddition of Ynones with Azomethine Ylides. *Org. Lett.* **2011**, *13*, 4680–4683.
- (458) Shi, F.; Tao, Z.-L.; Yu, J.; Tu, S. J.; Highly Enantioselective Synthesis of Biologically Important 2,5-Dihydropyrroles via Phosphoric Acid-Catalyzed Three-Component Reactions and Evaluation of Their Cytotoxicity. *Tetrahedron: Asymmetry* **2011**, *22*, 2056–2064.
- (459) Shi, F.; Xing, G.-J.; Tan, W.; Zhu, R.-Y.; Tu, S. Enantioselective Construction of 2,5-Dihydropyrrole Skeleton with Quaternary Stereogenic via Catalytic Asymmetric 1,3-Dipolar Cycloaddition Involving α -Arylglycine Esters. *Org. Biomol. Chem.* **2013**, *11*, 1482–1489.

- (460) Wang, Z.; Shi, Y.; Luo, X.; Han, D.-M.; Deng, W.-P. Direct Synthesis of Pyrroles via 1,3-Dipolar Cycloaddition of Azomethine Ylides with Ynones. *New J. Chem.* **2013**, *37*, 1742–1745.
- (461) Meng, J.; Wu, D.; Shi, Y.; Yu, X.; Deng, W.-P. Construction of 1*H*-Pyrrol-2-ylphosphonates via [3+2] Cycloaddition of Phosphate Azomethine Ylides with Ynones. *Tetrahedron* **2015**, *71*, 1074–1079.
- (462) Tang, F.-F.; Yang, W.-L.; Yu, X.; Deang, W.-P. Cu(OAc)₂/FOXAP Complex Catalyzed Construction of 2,5-Dihydropyrrole Derivatives via Asymmetric 1,3-Dipolar Cycloaddition of Azomethine Ylides to Ethynyl Ketones. *Catal. Sci. Technol.* **2015**, *5*, 3568–3575.
- (463) Abbiati, G.; Arcadi, A.; Marinelli, F.; Rossi, E. Domino [3+2] Cycloaddition/Annulation Reactions of β -(2-Aminophenyl)- α,β -ynones with Nitrile Oxides: Synthesis of Isoxazolo[4,5-*c*]quinolines. *Eur. J. Org. Chem.* **2003**, 1423–1427.
- (464) Willy, B.; Rominger, F.; Müller, T. J. J. Novel Microwave-Assisted One-Pot Synthesis of Isoxazoles by a Three-Component Coupling-Cycloaddition Sequence. *Synthesis* **2008**, 293–303.
- (465) Pramanik, M. M. D.; Kant, R.; Rastogi, N. Synthesis of 3-Carbonyl Pyrazole-5-phosphates via 1,3-Dipolar Cycloaddition of Bestmann-Ohira Reagent with Ynones. *Tetrahedron* **2014**, *70*, 5214–5220.
- (466) Kuroda, H.; Tomita, I.; Endo, T. Novel Phosphine-Catalyzed Zipper Cyclization of Aliphatic Diyne-Dione and Yne-Dione Systems. *Org. Lett.* **2003**, *5*, 129–131.
- (467) Wilson, J. E.; Sun, J.; Fu, G. C. Stereoselective Phosphine-Catalyzed Synthesis of Highly Functionalized Diquinanes. *Angew. Chem., Int. Ed.* **2010**, *49*, 161–163.
- (468) Meng, L.-G.; Cai, P.; Guo, Q.; Xue, X. Cycloaddition of Alkynyl Ketones with *N*-Tosylimines Catalyzed by Bu₃P and DMAP: Synthesis of Highly Functionalized Pyrrolidines and Azetidines. *J. Org. Chem.* **2008**, *73*, 8491–8496.
- (469) Lian, Z.; Shi, M. Nitrogen- and Phosphorous-Containing Lewis Base Catalyzed [4+2] and [3+2] Annulation Reactions of Isatins with But-3-yn-2-one. *Eur. J. Org. Chem.* **2012**, 581–586.
- (470) Lian, Z.; Wei, Y.; Shi, M. Phosphorous-Containing Lewis Base Catalyzed Highly Regioselective Cyclization of Isatin Derived Electron-Deficient Alkenes with But-3-yn-2-one. *Tetrahedron* **2012**, *68*, 2401–2408.
- (471) Lian, Z.; Shi, M. Asymmetric [3+2] Annulation of *N*-Protected Isatins with But-3-yn-2-one Catalyzed by DIOP: Facile Creation of Enantioenriched Spiro[furan-2,3'-indolime]-2',4(5*H*)-dione. *Org. Biomol. Chem.* **2012**, *10*, 8048–8050.
- (472) Yang, L.; Xie, P.; Li, E.; Li, X.; Huang, Y.; Chen, P. Phosphine-Catalyzed Domino Reaction: An Efficient Method for the Synthesis of Highly Functionalized Oxazolines. *Org. Biomol. Chem.* **2012**, *10*, 7628–7634.
- (473) Liang, L.; Li, E.; Xie, P.; Huang, Y. Phosphine-Initiated Domino Reaction: A Convenient Method for the Preparation of Spirocyclopentanones, *Chem. – Asian J.* **2014**, *9*, 1270–1273.

- (474) Ramachary, D. B.; Venkaiah, C.; Krishna, P. M. Stereoselective Synthesis of Five-Membered Spirooxindoles through Tomita Zipper Cyclization. *Org. Lett.* **2013**, *15*, 4714–4717.
- (475) Oppolzer, W. Intermolecular Diels-Alder Reactions. In *Comprehensive Organic Synthesis: Selectivity, Strategy & Efficiency in Modern Organic Chemistry*; Trost, B. M.; Fleming, I.; Paquette, L. A., Eds.; Pergamon Press: Oxford, U.K., 1991; pp 316–400.
- (476) Fringuelli, F.; Taticchi, A. *Dienes in the Diels-Alder Reaction*; John Wiley & Sons: New York, USA, 1990.
- (477) Fringuelli, F.; Taticchi, A. *The Diels-Alder Reaction: Selected Practical Methods*; John Wiley & Sons: New York, USA, 2003.
- (478) Winkler, J. D. Tandem Diels-Alder Cycloadditions in Organic Synthesis. *Chem. Rev.* **1996**, *96*, 167–176.
- (479) Fallis, A. G. Harvesting Diels and Alder's Garden: Synthetic Investigations of Intramolecular [4 + 2] Cycloadditions. *Acc. Chem. Res.* **1999**, *32*, 464 – 474.
- (480) Fallis, A. G. 1998 Alfred Bader Award Lecture Tangents and Targets: The Synthetic Highway from Natural Products to Medicine. *Can. J. Chem.* **1999**, *77*, 159-177.
- (481) Payette, J. N.; Yamamoto, H. Cationic-Oxazaborolidine-Catalyzed Enantioselective Diels-Alder Reaction of α,β -Unsaturated Acetylenic Ketones. *Angew. Chem., Int. Ed.* **2009**, *48*, 8060-8062.
- (482) Carmichael, R. A.; Sophanpanichkul, P.; Chalifoux, W. A. β -Silyl-Assisted Tandem Diels-Alder/Nazarov Reaction of 1-Aryl-3-(trimethylsilyl) Ynones. *Org. Lett.* **2017**, *19*, 2592–2595.
- (483) Carmichael, R. A.; Chalifoux, W. A. Multicomponent Double Diels–Alder/Nazarov Tandem Cyclization of Symmetric Cross-Conjugated Diynones to Generate [6-5-6] Tricyclic Products. *Chem. – Eur. J.* **2016**, *22*, 8781–8785.
- (484) Carmichael, R. A.; Chalifoux, W. A. One-Pot Synthesis of [6-5-6] Tricyclic Products via a Double Diels-Alder/Nazarov Tandem Reaction of Unsymmetrically Substituted Cross-Conjugated Diynones. *Tetrahedron* **2017**, *73*, 4084–4092.
- (485) Kumar, N.; Kiuchi, M.; Tallarico, J. A.; Schreiber, S. L. Small-Molecule Diversity Using a Skeletal Transformation Strategy. *Org. Lett.* **2005**, *7*, 2535–2538.
- (486) Schomburg, D.; Thielmann, M.; Winterfeld, E. Ansa-Steroids. *Tetrahedron Lett.* **1985**, *26*, 1705–1706.
- (487) Boukouvalas, J.; Thibault, C. Step-Economical Synthesis of the Marine Ascidian Antibiotics Cadiolide A, B, and D. *J. Org. Chem.* **2015**, *80*, 681–684.
- (488) Hu, Y.; Xu, K.; Zhang, S.; Guo, F.; Zha, Z.; Wang, Z. Copper-Catalyzed Enantioselective Hetero-Diels-Alder Reaction of Danishefsky's Diene with β,γ -Unsaturated α -Ketoesters. *Org. Lett.* **2014**, *16*, 3564–3567.
- (489) Chin, M. R.; Zlotkowski, K.; Han, M.; Patel, S.; Eliassen, A. M.; Axelrod, A.; Siegel, D. Expedite Access to Vinaxanthone and Chemically Edited Derivatives Possessing Neuronal Regenerative Effects through Ynone Coupling Reactions. *ACS Chem. Neurosci.* **2015**, *6*, 542–550.

- (490) Zhou, Q.-F.; Chu, X.-P. Ge, F. F.; Li, C.; Lu, T. Stereoselective Synthesis of Functionalized Spirocyclopentenoxindoles via Triphenylphosphine-Catalyzed [3+2] Cycloaddition Reactions. *Mol. Divers.* **2013**, *17*, 563–571.
- (491) Unsworth, W. P.; Cuthbertson, J. D.; Taylor, J. K. Total Synthesis of Spirobacillene A. *Org. Lett.* **2013**, *15*, 3306–3309.
- (492) Clarke, A. K.; Liddon, J. T. R.; Cuthbertson, J. D.; Taylor, R. J. K.; Unsworth, W. P. Dearomatisation Approaches to Spirocyclic Dienones via the Electrophilic Activation of Alkynes. *Org. Biomol. Chem.* **2017**, *15*, 233–245.
- (493) Wessig, P.; Müller, G. The Dehydro-Diels-Alder Reaction. *Chem. Rev.* **2008**, *108*, 2051–2063.
- (494) Li, W.; Zhou, L.; Zhang, J. Recent Progress in Dehydro(genative)-Diels-Alder Reaction. *Chem. – Eur. J.* **2016**, *22*, 1558–1571.
- (495) Wessig, P.; Müller, G.; Kühn, A.; Herve, R.; Blumenthal, H.; Troelenberg, S. The Photo-Dehydro-Diels-Alder Reaction: An Efficient Route to Naphthalenes. *Synthesis* **2005**, 1445–1454.
- (496) Wessig, P.; Müller, G.; Pick, C.; Matthes, A. The Photo-Dehydro-Diels-Alder (PDDA)-A Powerful Method for the Preparation of Biaryls. *Synthesis* **2007**, 467–477.
- (497) Zhang, X.-Y.; Shen, Z.; Hu, L.-L.; Wang, L.-J.; Lin, Y.-S.; Xie, J.-W.; Cui, H.-L. Microwave-Assisted Organocatalysis: Phosphine-Mediated Tomita-Zipper Cyclization Affording Functionalized Spirooxindole. *Tetrahedron Lett.* **2016**, *57*, 3790–3794.
- (498) Wang, Y.; Zhen, Z.; Zhang, L. Intramolecular Insertions into Unactivated C(sp³)-H Bonds by Oxidatively Generated β -Diketone- α -Gold Carbenes: Synthesis of Cyclopentanones. *J. Am. Chem. Soc.* **2015**, *137*, 5316–5319.
- (499) Ciesielski, J.; Gandon, V.; Frontier, A. J. Cascade Cyclizations of Acyclic and Macrocyclic Alkynones: Studies toward the Synthesis of Phomactin A. *J. Org. Chem.* **2013**, *78*, 9541–9552.
- (500) Brummond, K. M.; Mao, S.; Shinde, S. N.; Johnston, P. J.; Day, B. W. Design and Synthesis of a Library of Tetracyclic Hydroazulenoisoindoles. *J. Comb. Chem.* **2009**, *11*, 486–494.
- (501) Brummond, K. M.; Chen, D.; Pauter, T. O.; Mao, S.; Seifried, D. D. A Rh(I)-Catalyzed Cycloisomerization Reaction Affording Cyclic Trienones. *Synlett* **2008**, 749–764.
- (502) Hanzawa, Y.; Yabe, M.; Oka, Y.; Taguchi, T. Palladium-Catalyzed Reaction of Acylzirconocene Chloride and Stereoselective Formation of Bicyclo[3.3.0] Compounds. *Org. Lett.* **2002**, *4*, 4061–4064.
- (503) Raghu, M.; Grover, J. Ramasastry, S. S. V. Cyclopenta[b]annulation of Heteroarenes by Organocatalytic γ^{\prime} -[C(sp³)-H] Functionalization of Ynones. *Chem. – Eur. J.* **2016**, *22*, 18316–18321.
- (504) Graver, J.; Raghu, M.; Hazra, R.; Mondal, A.; Ramasastry, S. S. V. Organocatalytic γ^{\prime} -[C(sp³)-H] Functionalization of Ynones: An Usual Approach for the Cyclopentannulation of Benzothiophenes. *Synthesis* **2018**, *50*, 1462–1470.

- (505) Fedoseev, P.; Van der Eycken, E. Temperature Switchable Brønsted Acid-Promoted Selective Synthesis of Spiro-Indolynes and Quinolines. *Chem. Commun.* **2017**, *53*, 7732–7735.
- (506) Ji, K.; Yang, F.; Gao, S.; Tang, J.; Gao, J. Gold-Catalyzed Oxidation/C-H Functionalization of Ynones: Efficient and Rapid Access to Functionalized Polycyclic Salicyl Ketones. *Chem. – Eur. J.* **2016**, *22*, 10225–10229.
- (507) Pattenden, G.; Gonzalez, M. A.; McCulloch, S.; Walter, A.; Woodhead, S. J. A. A. Total Synthesis of Estrone Based on a Novel Cascade of Radical Cyclizations. *PNAS* **2004**, *101*, 12024–12029.
- (508) Zhu, G.; Wu, S.; Bao, X.; Cui, L.; Zhang, Y.; Qu, J.; Chen, H.; Wang, B. Asymmetric [3+2] Cycloaddition of 3-Amino Oxindole-Based Azomethine Ylides with α,β -Ynones: A Straightforward Approach to Spirooxindoles Incorporating 2,5-Dihydropyrroles and Pyrroles. *Chem. Commun.* **2017**, *53*, 4714–4717.
- (509) Vu, H. D.; Renault, J.; Roisnel, T.; Gouault, N.; Uriac, P. Synthesis of 3-Substituted Indolizidines from Amino-Ynones. *Tetrahedron Lett.* **2016**, *57*, 3036–3038.
- (510) Miaskiewicz, S.; Gaillard, B.; Kern, N.; Weibel, J.-M.; Pale, P.; Blanc, A. Gold(I)-Catalyzed N-Desulfonylative Amination versus N-to-O 1,5-Sulfonyl Migration: A Versatile Approach to 1-Azacycloalkanes. *Angew. Chem., Int. Ed.* **2016**, *55*, 9088–9092.
- (511) Zhang, X.; Xu, X. Silver-Catalyzed Oxidative Coupling of Anilines and Ene-Carbonyl/Acetylenic Carbonyl Compounds: An Efficient Route for the Synthesis of Quinolines. *Chem. – Asian J.* **2014**, *9*, 3089–3093.
- (512) Liu, C.; Zhang, Z.; Zhang, J.; Liu, X.; Xie, M. Regioselective Synthesis of Aurone Derivatives via PBU₃-Catalyzed Cyclization of 2-Alkynoylphenols. *Chim. J. Chem.* **2014**, *32*, 1233–1237.
- (513) Takai, K.; Morita, R.; Sakamoto, S.; Preparation of 2,5-Disubstituted Furans from terminal Ynones and Aldehydes with CrCl₂, Me₃SiCl, and H₂O. *Synlett* **2001**, 1614–1616.
- (514) Ge, G.-C.; Mo, D.-L.; Ding, C.-H.; Dai, L.-X.; Hou, X.-L. Palladacycle-Catalyzed Reaction of Bicyclic Alkenes with Terminal Ynones: Regioespecific Synthesis of Polysubstituted Furans. *Org. Lett.* **2012**, *14*, 5756–5759.
- (515) Tsui, W.-K.; Chung, L.-H.; Tsang, W.-H.; Yeung, C.-H.; Chiu, C.-H.; Lo, H.-S.; Wong, C.-Y. Synthesis, Spectroscopic and Theoretical Studies of Ruthenafuran and Osmafuran Prepared by Activation of Ynone in Alcohol. *Organometallics* **2015**, *34*, 1005–1012.
- (516) Vollhardt, P.; Shore, N. *Organic Chemistry: Structure and Function*, 8th Edition; W. H. Freeman: 2018; Chapter 13.
- (517) Lindlar, H. Ein neuer Katalisator für selective Hydrirungen. *Helv. Chim. Acta* **1952**, *35*, 446–450.
- (518) Lindlar, H.; Dunuis, R. Palladium Catalyst for Partial Reduction of Acetylenes. *Org. Synth.* **1966**, *Coll. Vol. 5*, 880–883.
- (519) Zimmerman, H. E.; Dodd, J. R. Electron Delocalization in Molecules Containing Formally Orthogonal π -Systems. Synthesis of 2,4,6,2',4',6'-Hexa-*tert*-butyldiphenylacetylene and a Study of its Radical Anion. *J. Am. Chem. Soc.* **1970**, *92*, 6507–6515.

- (520) Tsai, M.-S.; Rao, U. N.; Wang, J.-R.; Liang, C.-H.; Yeh, M.-C. P. Triphenylphosphine-Mediated Reduction of Electron-Deficient Propargyl Ethers to the Allylic Ethers. *J. Chin. Chem. Soc.* **2001**, *48*, 869–876.
- (521) Krug, C.; Hartwig, J. F. Reactions of an Arylrhodium Complex with Aldehydes, Imines and Alkynes. New Classes of Insertion Reactions. *Organometallics* **2004**, *23*, 4594–4607.
- (522) Sydnes, L. K.; Holmelid, B.; Kvernenes, O. H.; Valdersnes, S.; Hodne, M.; Boman, K. Stereospecific Synthesis of Allylic and Homoallylic Alcohols from Functionalized Propargylic Alcohols. *ARKIVOC* **2008**, (xiv), 242–268.
- (523) Sánchez-Díez, E.; Fernández, M. Uria, U.; Reyes, E.; Carrillo, L.; Vicario, J. L. Enantioselective Synthesis of Tertiary Propargylic Alcohols under N-Heterocyclic Carbene Catalysis. *Chem. – Eur. J.* **2015**, *21*, 8384–8388.
- (524) Friel, D. K.; Snapper, M. L.; Hoveyda, A. H. Aluminum-Catalyzed Asymmetric Alkylations of Pyridyl-Substituted Alkynyl Ketones with Dialkylzinc Reagents. *J. Am. Chem. Soc.* **2008**, *131*, 9942–9951.
- (525) Garcia, J. M.; Odriozola, J. M.; Razkin, J.; Lapuertas, I.; Odriozola, A.; Urruzuno, I.; Vera, S.; Oyarbide, M.; Palomo, C. Catalytic Enantioselective Quick Route to Aldol-Tethered 1,6- and 1,7-Enynes from ω -Unsaturated Aldehydes. *Chem. – Eur. J.* **2014**, *20*, 15543–15554.
- (526) Jenkins, T. J.; Burnell, D. J. Lewis Acid Catalyzed Geminal Acylation Reaction of Ketones with 1,2-Bis[(trimethylsilyl)oxy]cyclobutene: Direct Formation of 2,2-Disubstituted 1,3-Cyclopentanediones. *J. Org. Chem.* **1994**, *59*, 1485–1491.
- (527) Zhang, T.; Takano, A.; Nishiyama, Y.; Makawa, H. Magnesium-Promoted Reductive Acylation of Aromatic Conjugated Ynones Accompanying with Transposition of the Triple Bond. *Tetrahedron* **2015**, *71*, 2629–2635.
- (528) Yi, C.; Blum, C.; Liu, S.-X.; Frei, G.; Neels, A.; Renaud, P.; Letwyler, S.; Decurtins, S. An Efficient and Facile Synthesis of Highly Substituted 2,6-Dicyanoanilines. *J. Org. Chem.* **2008**, *73*, 3596–3599.
- (529) Morisaki, Y.; Luu, J.; Tykwinski, R. R. A One-Pot Synthesis and Functionalization of Polyynes. *Org. Lett.* **2006**, *8*, 689–692.
- (530) Sinha, D.; Biswas, A.; Sing, V. Chiral Phosphine-Silver(I) Complex Catalyzed Enantioselective Interrupted Feist-Bénary Reaction with Ynones: The Aldol Cyclomerization Cascade. *Org. Lett.* **2015**, *17*, 3302–3305.
- (531) Sasaki, S.; Ikekame, Y.; Tanayama, M.; Yamaguchi, T.; Higashiyama, K. Brønsted Acid Catalyzed Friedel-Crafts Alkylation Reactions of Trifluoromethyl- α,β -ynones with Indoles. *Synlett* **2012**, *23*, 2699–2703.
- (532) Baglai, I.; Maraval, V.; Voitenko, Z. V.; Duhayon, C.; Volovenko, Y. M.; Chauvin, R. First Evidence of 1,3-Bis-Indolylallenes: Generation by a Sequential Double Nucleophilic Process from Ynones. *Synth. Commun.* **2015**, *45*, 253–261.
- (533) Praveen, C.; Kalyanasundaram, A.; Perumal, P. T. Gold(III)-Catalyzed Synthesis of Isoxazoles by Cycloisomerization of α,β -Acetylenic Oximes. *Synlett* **2010**, 777–781.

- (534) Uraguchi, D.; Ito, T.; Nakamura, S.; Ooi, T. Catalytic Asymmetric Hydrophosphonylation of Ynones. *Chem. Sci.* **2010**, *1*, 488–490.
- (535) François-Endelmond, C.; Carlin, T.; Thuery, P.; Loreau, O.; Taran, F. A Phosphine-Mediated Construction of 1,4-Oxazepines and 1,3-Oxazines. *Org. Lett.* **2010**, *12*, 40–42.
- (536) Vu, H.-D.; Renault, J.; Roisne., T.; Gouault, N.; Uriac, P.; Methanesulfonic Acid Mediated Cyclization and Meyer-Schuster Rearrangement of γ -Amino Ynones: Access to Enantiopure Pyrrolidine Exocyclic Vinilogenous Amides. *Eur. J. Org. Chem.* **2014**, 4506–4514.
- (537) Vu, H.-D.; Renault, J.; Roisnel, T.; Rober C.; Jéhan, P.; Goault, N.; Uriac, P. Reactivity of *N*-Boc-Protected Amino Ynones in the Presence of Zinc Chloride: Formation of Acetylenic Cyclic Imines and Their Palladium Complexes. *Eur. J. Org. Chem.* **2015**, 4868–4875.
- (538) Trost, B. M.; Quintard, A. Asymmetric Catalytic Synthesis of the Proposed Structure of Trocheliophorolide B. *Org. Lett.* **2012**, *14*, 4698–4700.
- (539) Yu, C.-M.; Kim, C.; Kweon, J.-H. Enantioselective Synthesis of Allenyl Carbinols by the CBS Reduction in Nitromethane: Dramatic Solvent Effect for Reactivity and Enantioselectivity. *Chem. Commun.* **2004**, 2494–2495.
- (540) Williams, D. R.; Fromhold, M. G.; Earley, J. D. Total Synthesis of (–)-Stemospironine. *Org. Lett.* **2001**, *3*, 2721–2724.
- (541) Temperini, A.; Tiecco, M.; Testaferri, L.; Terlizzi, R. Novel Stereoselective Synthesis of (*R*)-Aminotetradecanoic Acid (Iturinic Acid). *Lett. Org. Chem.* **2009**, *6*, 22–24.
- (542) Eagon, S.; DeLieto, C.; McDonald, W. J.; Haddenham, D.; Saavedra, J.; Kim, J.; Singaram, B. Mild and Expedient Asymmetric Reductions of α,β -Unsaturated Alkenyl and Alkynyl Ketones by TarB-NO₂ and Mechanistic Investigations of Ketone Reduction. *J. Org. Chem.* **2010**, *75*, 7717–7725.
- (543) Mulzer, M.; Tiegs, B. J.; Wang, Y.; Coates, G. W.; O'Doherty, G. A. Total Synthesis of Tetrahydrolipstatin and Stereoisomers via a Highly Regio- and Diastereoselective Carbonylation of Epoxyhomoallylic Alcohols. *J. Am. Chem. Soc.* **2014**, *136*, 10814–10820.
- (544) Kang, G.; Jiang, J.; Liu, H.; Wu, H. Asymmetric Organocatalytic Synthesis of β -Hydroxyynones with a Quaternary Carbon Center under Aqueous Conditions. *J. Braz. Chem. Soc.* **2012**, *23*, 5–10.
- (545) Trost, B. M.; Bartlett, M. J. Prophenol-Catalyzed Asymmetric Additions by Spontaneously Assemble Dinuclear Main Group Metal Complexes. *Acc. Chem. Res.* **2015**, *48*, 688–701.
- (546) Trost, B. M.; Fettes, A.; Shireman, B. T. Direct Catalytic Asymmetric Aldol Additions of Methyl Ynones. Spontaneous Reversal in the Sense of Enantioinduction. *J. Am. Chem. Soc.* **2004**, *126*, 2660–2661.
- (547) Beletskaya, I. P.; Nájera, C.; Yus, M. Stereodivergent Catalysis. *Chem. Rev.* **2018**, *118*, 5080–5200.

- (548) Trost, B. M.; Hung, C.-I. Broad Spectrum Enolate Equivalent for Catalytic Chemo-, Diastereo-, and Enantioselective Addition to *N*-Boc Imines. *J. Am. Chem. Soc.* **2015**, *137*, 15940–15946.
- (549) Liu, W.; Zou, L.; Fu, B.; Wang, X.; Wang, K.; Sun, Z.; Peng, F.; Wang, W.; Shao, Z. A. Multifaceted Directing Group Switching Ynones as Michael Donors in Chemo-, Enantio- and γ -Selective 1,4-Conjugate Addition with Nitroolefins. *J. Org. Chem.* **2016**, *81*, 8296–8305.
- (550) Kim, N.-J.; Moon, H.; Park, T.; Yun, H.; Jung, J.-W.; Chang, D.-J.; Kim, D.-D.; Suh, Y.-G. Concise and Enantioselective Total Synthesis of 15-Deoxy- $\Delta^{12,14}$ -Prostaglandin J₂. *J. Org. Chem.* **2010**, *75*, 7458–7460.
- (551) Wender, P. A.; Stemmeler, R. T.; Sirois, L. E. A Metal-Catalyzed Intermolecular [5+2] Cycloaddition/Nazarov Cyclization Sequence and Cascade. *J. Am. Chem. Soc.* **2010**, *132*, 2532–2533.
- (552) Liu, Y.; Kang, T.-R.; Liu, Q.-Z.; Chen, L.-M.; Wang, Y.-C.; Liu, J.; Xie, Y.-M.; Yang, J.-L.; He, L. Enantioselective [4+2] Cycloaddition of Cyclic *N*-Sulfinimines and Acyclic Enones or Ynones: A Concise Route to Sulfamidate-Fused 2,6-Disubstituted Piperidin-4-ones. *Org. Lett.* **2013**, *15*, 6090–6093.
- (553) Gao, X.; Yang, W.; Liu, Y.; Chen, W.; Zhang, C.; Zheng, L.; Guo, H. Phosphine-Catalyzed [3+2] and [3+4] Annulation Reactions of Ynones with Barbiturate-Derived Alkenes. *Org. Biomol. Chem.* **2017**, *15*, 5298–5307.
- (554) Chen, Z.-S.; Yang, F.; Ling, H.; Li, M.; Gao, J.-M.; Ji, K. Metal-Free, Site-Selective Addition to Ynones: An Approach to Synthesize Quinoline Derivatives. *Org. Lett.* **2016**, *18*, 5828–5831.
- (555) Sadamitsu, Y.; Komatsuki, K.; Saito, K.; Yamada, T. Access to Tetrionic Acids via Silver-Catalyzed CO₂ Incorporation into Conjugated Ynones. *Org. Lett.* **2017**, *19*, 3191–3194.
- (556) Silva, F.; Sawicki, M.; Gouverneur, V. Enantioselective Organocatalytic Aldol Reaction of Ynones and Its Synthetic Applications. *Org. Lett.* **2006**, *8*, 5417–5419.
- (557) Tejedor, D.; García-Tellado, F.; Marreto-Tellado, J. J.; de Armas, P. Efficient Domino Process Based on the Catalytic Generation of Non-Metalated, Conjugated Acetylides in the Presence of Aldehydes or Activated Ketones. *Chem. – Eur. J.* **2003**, *9*, 3122–3131.
- (558) Li, C.; Yu, H.; Liu, Y.; Zhou, L.; Sun, Z.; Guo, H. Phosphane-Catalyzed [3+3] Annulation of C,N-Cyclic Azomethine Imines with Ynones: A Practical Method for Tricyclic Dinitrogen-Fused Heterocycles. *Adv. Synth. Catal.* **2016**, *358*, 1880–1885.
- (559) Kavthe, R. D.; Bansode, A. H.; Patil, N. T. Scandium Triflate Catalyzed Unexpected Cleavage of C-C Bonds in Ynones. *ARKIVOC* **2016**, (ii), 223–232.
- (560) Liu, H.-L.; Jiang, H.-F.; Xu, L.; Zhan, H.-Y. Solvent-Free Heterogeneous Organocatalysis: Stereoselective Isomerization of α,β -Ynones to (*E,E*)- $\alpha,\beta,\gamma,\delta$ -Dienones Catalyzed by Polymer-Supported Tertiaryphosphines. *Tetrahedron Lett.* **2007**, *48*, 8371–8375.

- (561) Wang, Y.; Jiang, H.; Liu, H.; Liu, P. Polymeric Tertiaryphosphine as a Green and Recyclable Organocatalyst for Stereoselective Isomerization Reaction. *Tetrahedron Lett.* **2005**, *46*, 3935–3937.
- (562) Georgy, M.; Lesot, P.; Campagne, J.-M. Synthetic Studies on Macrolactim A: Construction of C4-C24 Fragment. *J. Org. Chem.* **2007**, *72*, 3543–3549.
- (563) Shaw, M. J.; Bryant, S. W.; Rath, N. η^1 -Vinylidene Formation from Internal Alkynes by C-C Bond Migration. *Eur. J. Inorg. Chem.* **2007**, 3943–3946.
- (564) Sing, V. K.; Bustelo, E.; de los Rios, I.; Macías-Arce, I.; Puerta, M. C.; Valerga, P.; Ortuño, M. A.; Ujaque, G.; Lledós, A. Internal Alkyne Isomerization to Vinylidene versus Stable π -Alkyne: Theoretical and Experimental Study on the Divergence of Analogous Cp*Ru and TpRu Systems. *Organometallics* **2011**, *30*, 4014–4031.
- (565) Xu, P.; Yao, Y.; Xu, X. Frustrated Lewis Pair-Like Reactivity of Rare-Earth Metal Complexes: 1,4-Addition Reactions and Polymerizations of Conjugate Polar Alkenes. *Chem. – Eur. J.* **2017**, *23*, 1263–1267.
- (566) Szesni, N.; Weibert, B.; Fischer, H. Alkoxy-Substituted Group 6 Allenylidene Complexes-Synthesis and Properties. *Inorg. Chim. Acta* **2006**, *359*, 617–632.
- (567) Wang, X.; Wang, Z.; Xie, Z.; Zhang, G.; Zhang, W. Functionalized α,β -Ynones: Efficient Ligand for Cu Catalyzed Sonogashira-Type Cross-Coupling Reaction. *RCS Adv.* **2016**, *6*, 109296–109300.
- (568) Yadav, J. S.; Reddy, B. V. S.; Gupta, M. K.; Dash, U.; Pandey, S. K. Gallium(III) Chloride Catalyzed Stereoselective Synthesis of *E*-Configured α,β -Unsaturated Ketones. *Synlett* **2007**, 809–811.
- (569) Heasley, V. L.; Buczala, D. M.; Chappell, A. E.; Hill, D. J.; Whisenand, J. M.; Shellhamer, D. F. Addition of Bromine Chloride and Iodide Monochloride to Carbonyl-Conjugated, Acetylenic Ketones: Synthesis and Mechanism. *J. Org. Chem.* **2002**, *67*, 2183–2187.
- (570) Dermenci, A.; Whittaker, R. E.; Dong, G. Rh(I)-Catalyzed Decarbonylation of Diynones via C–C Activation: Orthogonal Synthesis of Conjugated Diynes. *Org. Lett.* **2013**, *15*, 2242–2245.
- (571) Dermenci, A.; Whittaker, R. E.; Gao, Y.; Cruz, F. A.; Yu, Z.-X.; Dong, G. Rh-Catalyzed Decarbonylation of Conjugated Ynones *via* Carbon-Alkyne Bond Activation: Reaction Scope and Mechanistic Exploration *via* DFT Calculations. *Chem. Sci.* **2015**, *6*, 3201–3210.
- (572) Mahmood, A.; Ngenci, R.; Penner, P. M.; Green, J. R. Remote Functionalization in Nicholas Reactions of Vinylogous γ -Carbonyl Cations. *Synlett* **2016**, *27*, 1245–1250.
- (573) Xu, B.-H.; Kehr, G.; Fröhlich, R.; Wibbeling, B.; Schrimmer, B.; Grimme, S.; Erker, G. Reaction of Frustrated Lewis Pairs with Conjugated Ynones-Selective Hydrogenation of the Carbon-Carbon Triple Bond. *Angew. Chem., Int. Ed.* **2011**, *50*, 7183–7186.
- (574) Xu, B.-H.; Adler Yanez, R. A.; Nakatsuka, H.; Kitamura, M.; Fröhlich, R.; Kehr, G.; Erker, G. Reaction of Frustrated Lewis Pair with Ketone and Esters. *Chem. – Asian J.* **2012**, *7*, 1347–1356.

TOC graphic

