

# Group Belief

Thomas Ågotnes<sup>1,2</sup> and Yi N. Wang<sup>3</sup>

<sup>1</sup> Southwest University, China

<sup>2</sup> University of Bergen, Norway

`thomas.agotnes@uib.no`

<sup>3</sup> Zhejiang University, China

`ynw@xixilogic.org`

**Abstract.** While logical formalizations of group notions of knowledge such as common and distributed knowledge have received considerable attention in the literature, most approaches being based on modal logic, group notions of *belief* have received much less attention. In this paper we systematically study standard notions of group knowledge and belief under different assumptions about which properties knowledge and belief have. In particular, we map out (lack of) preservation of knowledge/belief properties against different standard definitions of group knowledge/belief. It turns out that what is called group belief most often is not actually belief, i.e., does not have the properties of belief. In fact, even what is called group knowledge is sometimes not actually knowledge either. For example, under the common assumption that belief has the KD45 properties, distributed belief is not actually belief (it does not satisfy the D axiom). In the literature there is no detailed completeness proof for axiomatizations of KD45 with distributed belief that we are aware of, and there has been some confusion regarding soundness of such axiomatizations related to the mentioned lack of preservation. In this paper we also present a detailed completeness proof for a sound axiomatization of KD45 with distributed belief.

**Keywords:** knowledge · belief · doxastic logic · epistemic logic · group belief · distributed belief

## 1 Introduction

Different notions of group knowledge, such as common knowledge or distributed knowledge, have received considerable attention in the epistemic logic literature [20, 8, 5]. While most frameworks for epistemic logic are based on the modal logic S5 for modeling individual knowledge, frameworks for belief usually are based on weaker systems such as KD45 or K45. Group belief is routinely defined in the same way as group knowledge in such belief logics, but has received far less attention in the literature. In this paper we take a systematic look at standard notions of group knowledge and belief under different assumptions about which properties knowledge and belief have. A key question is whether or not properties of belief (e.g., KD45 or K45 properties) are *preserved* under the operations

defining group knowledge from individual knowledge. We map out the answers to that question, for different assumptions about what the properties of knowledge and belief are against different definitions of group knowledge.

As an example, if we assume that individual belief has the KD45 properties it is not guaranteed that *distributed* belief has it – the intersection of two serial, transitive and Euclidean binary relations is not necessary serial, so distributed belief on KD45 lacks the *consistency* property (D axiom). Thus, if we assume that belief has the KD45 properties, then “distributed belief” *is not belief*. In fact, we argue that group belief *most often* is not belief; only under very weak or very strong assumptions about what belief is, are standard notions of group belief actually belief. Similarly, group *knowledge* is not always (S5) knowledge either.

Some of these observations are folklore in the epistemic/doxastic logic community. However, we are not aware of any existing systematic study. And there is evidence that more awareness of the properties of group belief is needed. As far as we are aware, no completeness proof for KD45 with distributed belief exists in print. Furthermore, there is a problem with the soundness of an axiomatization of doxastic logic with distributed belief on KD45 in the literature [8], exactly due to the lack of preservation of the consistency property for distributed belief on KD45. In this paper we provide a detailed completeness proof for a sound axiomatization of KD45 with distributed belief.

The rest of the paper is organized as follows. In the next section we introduce the background from the literature: modal logics of knowledge and belief, definitions of group knowledge and belief, and standard (combinations of) axioms corresponding to properties of knowledge and belief. In Section 3 we systematically look at (lack of) preservation of properties under different notions of group belief. A few preservation results have been established already in existing work on graph aggregation [6]. Key observations here are summed up in Figure 1 on p. 8. In Section 4 we discuss axiomatizations of KD45 with distributed belief in the literature and present a detailed completeness result for a sound axiomatization. We discuss related and future work and conclude in Section 5.

## 2 Background

We briefly review the standard language and semantics of modal epistemic and doxastic logic. We refer to, e.g., [8] for more details.

Let  $\text{PROP}$  be a countable set of propositional variables, let  $\text{AG}$  be a finite set of agents, and let  $\text{GR} = \wp(\text{AG}) \setminus \{\emptyset\}$  be the set of groups, i.e., the set of all non-empty sets of agents. We define the following variants of the epistemic language with individual belief operators  $B_a$  and with or without various combinations of group belief operators  $E_G$ ,  $C_G$  and  $D_G$ .

**Definition 1 (languages).**

$$\begin{aligned}
(\mathcal{BL}) \quad \varphi &::= p \mid \neg\varphi \mid (\varphi \wedge \psi) \mid B_a\varphi \\
(\mathcal{BLC}) \quad \varphi &::= p \mid \neg\varphi \mid (\varphi \wedge \psi) \mid B_a\varphi \mid E_G\varphi \mid C_G\varphi \\
(\mathcal{BLD}) \quad \varphi &::= p \mid \neg\varphi \mid (\varphi \wedge \psi) \mid B_a\varphi \mid D_G\varphi \\
(\mathcal{BLCD}) \quad \varphi &::= p \mid \neg\varphi \mid (\varphi \wedge \psi) \mid B_a\varphi \mid E_G\varphi \mid C_G\varphi \mid D_G\varphi
\end{aligned}$$

where  $p \in \text{PROP}$ ,  $a \in \text{AG}$  and  $G \in \text{GR}$ . Boolean operators such as  $\top$ ,  $\rightarrow$ ,  $\vee$  and so on are defined as usual.

While some works (e.g., [8]) use the notation  $K_a$  for both individual knowledge and the more general notion of individual belief, we chose to use  $B_a$  for both, treating knowledge as a special case of belief – belief as a generalization of knowledge.  $E_G$  is the operator for what is called *general belief*, or *everybody-believes* or *mutual belief*,  $C_G$  is *common belief*, and  $D_G$  is *distributed belief* (or knowledge).

A Kripke model  $M$  (over agents AG and propositional variables PROP) is a triple  $(S, R, V)$ , where  $S$  is a nonempty set of states,  $R : \text{AG} \rightarrow \wp(S \times S)$  assigns to every agent  $a$  a binary relation  $R_a$  on  $S$ , and  $V : \text{PROP} \rightarrow \wp(S)$  is a valuation which associates with every propositional variable a set of states where it is true. For any  $s \in S$ , the pair  $(M, s)$  is called a *pointed model*.

**Definition 2 (satisfaction).** *The truth in, or satisfaction by, a pointed model  $(M, s)$  with  $M = (S, R, V)$  of a formula  $\varphi$ , denoted  $(M, s) \models \varphi$ , is defined inductively as follows.*

$$\begin{aligned}
(M, s) \models p & \quad \text{iff} \quad s \in V(p) \\
(M, s) \models \neg\varphi & \quad \text{iff} \quad \text{not } (M, s) \models \varphi \\
(M, s) \models (\varphi \wedge \psi) & \quad \text{iff} \quad (M, s) \models \varphi \text{ and } (M, s) \models \psi \\
(M, s) \models B_a\varphi & \quad \text{iff} \quad \text{for all } t \in S, \text{ if } sR_a t \text{ then } (M, t) \models \varphi \\
(M, s) \models E_G\varphi & \quad \text{iff} \quad \text{for all } t \in S, \text{ if } sR_G^E t \text{ then } (M, t) \models \varphi \\
(M, s) \models C_G\varphi & \quad \text{iff} \quad \text{for all } t \in S, \text{ if } sR_G^C t \text{ then } (M, t) \models \varphi \\
(M, s) \models D_G\varphi & \quad \text{iff} \quad \text{for all } t \in S, \text{ if } sR_G^D t \text{ then } (M, t) \models \varphi
\end{aligned}$$

where  $R_G^E = \bigcup_{a \in \text{AG}} R_a$ ,  $R_G^C$  is the transitive closure of  $R_G^E$ , and  $R_G^D = \bigcap_{a \in \text{AG}} R_a$ . We say that  $\varphi$  is (globally) true in a model, if it is satisfied at all states of that model.

As discussed below, we restrict the class of models depending on which properties we assume that belief has, the strongest assumption being that the relations are *equivalence relations* in the case of *knowledge*.

The semantics for group belief given above are the standard definitions in the literature. In particular, the definition of the common knowledge/belief relation as the transitive closure of the union of the individual knowledge/belief relations is the one used in, e.g., the standard textbook [8]<sup>4</sup> – not only for knowledge but

<sup>4</sup> The concrete definition of the semantics of common belief in [8], as well as in many other works (e.g. [12, 15, 13, 16, 17, 7, 9, 22]), is that  $(M, s) \models C_G\varphi$  iff  $\forall k \geq 1 :$

also for weaker notions of belief. Some works, however (e.g., [4, 19, 5]), use a slightly different definition, namely the *reflexive* transitive closure – although almost always only in the context of S5 knowledge, in which case the two definitions are equivalent. In the following we will still consider the latter as a possible, alternative definition for common belief a few times. When referring to common belief we will henceforth mean the former definition, using transitive closure, if not otherwise stated. The latter definition, using the reflexive transitive closure, will be referred to as “the alternative definition” when needed.

Given a class  $\mathcal{C}$  of models and a formula  $\varphi$ , we say  $\varphi$  is *valid* in  $\mathcal{C}$  if and only if  $\varphi$  is globally true in all models of  $\mathcal{C}$ . We usually do not choose a class of models arbitrarily, but are rather interested in those based on a certain set of conditions over the binary relations in a model. Such conditions are often called *frame conditions*. In this paper we are going to focus on only some frame conditions, namely those that play the most prominent roles in the context of knowledge and belief. These conditions are

- (l) *seriality*:  $\forall s \in S \exists t \in S sR_at$ ,
- (r) *reflexivity*:  $\forall s \in S sR_as$ ,
- (t) *transitivity*:  $\forall s, t, u \in S ((sR_at \ \& \ tR_au) \Rightarrow sR_au)$ ,
- (s) *symmetry*:  $\forall s, t \in S (sR_at \Rightarrow tR_as)$ , and
- (e) *Euclidicity*:  $\forall s, t, u \in S ((sR_at \ \& \ sR_au) \Rightarrow tR_au)$ .

It is well known that these frame conditions are characterized by the axioms

- D**  $B_a\varphi \rightarrow \neg B_a\neg\varphi$ ,
- T**  $B_a\varphi \rightarrow \varphi$ ,
- 4**  $B_a\varphi \rightarrow B_aB_a\varphi$ ,
- B**  $\neg\varphi \rightarrow B_a\neg B_a\varphi$ , and
- 5**  $\neg B_a\varphi \rightarrow B_a\neg B_a\varphi$ ,

respectively (see, e.g., [3]). There are 32 combinations of these 5 frame properties, potentially giving rise to 32 classes of models, but some of the combinations are equivalent.

In Table 1 we list the 32 different combinations over the 5 frame properties, and the corresponding logics over the language  $\mathcal{BL}$  (i.e., the set of valid formulas on the corresponding model classes). There are 15 different logics up to logical equivalence. For logics based on the language  $\mathcal{BLC}$ , we add a superscript  $C$  to the name, as in  $K^C$ ,  $D^C$ ,  $T^C$ ,  $S4^C$ ,  $S5^C$ ,  $KD4^C$ ,  $K45^C$ , and so on. Similarly, for logics based on the language  $\mathcal{BLD}$ , we add a superscript  $D$ , e.g.,  $K45^D$ ,  $KD45^D$ , and so on. We can use this notation for logics over  $\mathcal{BLCD}$  as well.

As is convention, because of the correspondence between frame conditions and characterization axioms, we often use the names of the corresponding logics to refer to the class of models. For example, the word “T models” simply stands for the class of models based on reflexive frames, and similarly “S5 models”

---

( $M, s$ )  $\models E_G^k\varphi$ , where  $E_G^1\varphi$  stands for  $E_G\varphi$  and  $E_G^{k+1}\varphi$  for  $E_GE_G^k\varphi$ . As noted by [8, Lemma 2.2.1] that definition is equivalent to using the transitive closure (for arbitrary models, not only S5 models).

**Table 1.** Model classes and corresponding logics over the language  $\mathcal{BL}$ , with alternative names from the literature. Names of logics that are equivalent to one with fewer characterization axioms/frame conditions are in parentheses.

Frame cond.	Full name	Short name	Equivalent logic	Frame cond.	Full name	Short name	Equivalent logic
—	K	—	—	lrt	(KDT4)	—	S4
l	KD	D	—	lrs	(KDTB)	—	B
r	KT	T	—	lre	(KDT5)	—	S5
t	K4	—	—	lts	(KD4B)	—	S5
s	KB	—	—	lte	KD45	—	—
e	K5	—	—	lse	(KDB5)	—	S5
lr	(KDT)	—	T	rts	(KT4B)	—	S5
lt	KD4	—	—	rte	(KT45)	—	S5
ls	KDB	—	—	rse	(KTB5)	—	S5
le	KD5	—	—	tse	(K4B5)	—	K4B
rt	KT4	S4	—	lrts	(KDT4B)	—	S5
rs	KTB	B	—	lrte	(KDT45)	—	S5
re	KT5	S5	—	lrse	(KDTB5)	—	S5
ts	K4B	—	—	ltse	(KD4B5)	—	S5
te	K45	—	—	rtse	(KT4B5)	—	S5
se	KB5	—	K4B	lrtse	(KDT4B5)	—	S5

means the class of models based on reflexive and Euclidean (and therefore also transitive and symmetric) frames. As already mentioned, we use “knowledge” as a special case of belief, i.e., when belief is assumed to have the S5 properties.

### 3 Group belief in different logics

In this section we look at (the lack of) preservation of properties of belief when going from individual to group belief. Syntactically, this corresponds to whether group belief satisfies the same axioms as individual belief; semantically it corresponds to whether frame conditions are preserved under the group belief operations (union, intersection, etc.). As mentioned in the previous section we only consider combinations of the five frame conditions seriality, reflexivity, transitivity, symmetry and Euclidicity.

**Definition 3 (preservation).** *Given a model  $M = (S, R, V)$  and a combination of frame conditions  $\mathcal{F}$  (i.e.,  $\mathcal{F} \subseteq \{l, r, t, s, e\}$ ), we say that:*

1.  $\mathcal{F}$  is preserved for general belief in  $M$ , or general belief preserves  $\mathcal{F}$  in  $M$ , if  $R_G^E$  satisfies  $\mathcal{F}$  whenever  $R_a$  satisfies  $\mathcal{F}$  for every  $a \in G$ , for any group  $G$ ;
2.  $\mathcal{F}$  is preserved for common belief in  $M$ , or common belief preserves  $\mathcal{F}$  in  $M$ , if  $R_G^C$  satisfies  $\mathcal{F}$  whenever  $R_a$  satisfies  $\mathcal{F}$  for every  $a \in G$ , for any group  $G$ ;

3.  $\mathcal{F}$  is preserved for distributed belief in  $M$ , or distributed belief preserves  $\mathcal{F}$  in  $M$ , if  $R_G^D$  satisfies  $\mathcal{F}$  whenever  $R_a$  satisfies  $\mathcal{F}$  for every  $a \in G$ , for any group  $G$ .

A combination of frame conditions is preserved for a variant of group belief on a class of models iff it is preserved in every model in that class.

This notion of preservation is standard in modal logic [3]. It also corresponds to what is called *collective rationality* in [6] (see Section 5 for more details).

It is preservation on a class of models we are interested in. This says that the properties are *guaranteed* to hold on that model class, for example that Euclidicity is preserved for common belief on S5 models. Conversely, if a combination of properties is *not* preserved on a class of models it means that there is at least one model in that class where it is not preserved.

**Lemma 1.** *The following hold:*

1. *Seriality*
  - (a) *is preserved for general and common belief on the class of all models;*
  - (b) *is preserved for distributed belief on the class of all reflexive models;*
  - (c) *is not preserved for distributed belief on the class of  $\mathcal{F} \cup \{l\}$  models, for any  $\mathcal{F} \subseteq \{t, e\}$ ;*
  - (d) *is not preserved for distributed belief on the class of  $\{l, s\}$  models.*
2. *Reflexivity is preserved for general, common and distributed belief on the class of all models.*
3. *Transitivity*
  - (a) *is not preserved for general belief on the class of all  $\mathcal{F} \cup \{t\}$  models, for any  $\mathcal{F} \subseteq \{l, r, s, e\}$ ;*
  - (b) *is preserved for common and distributed belief on the class of all models.*
4. *Symmetry is preserved for general, common and distributed belief on the class of all models.*
5. *Euclidicity*
  - (a) *is not preserved for general belief on the class of all  $\mathcal{F} \cup \{e\}$  models, for any  $\mathcal{F} \subseteq \{l, r, t, s\}$ ;*
  - (b) *is preserved for common belief on the class of all symmetric models;*
  - (c) *is not preserved for common belief on the class of all  $\mathcal{F} \cup \{e\}$  models, for any  $\mathcal{F} \subseteq \{l, t\}$ ;*
  - (d) *is preserved for distributed belief on the class of all models.*

*Proof.*

1. (a) Straightforward: the (transitive closure of) the union of serial relations is serial.
- (b) Follows from point 2 below.
- (c) The following KD45 model is a counter-example for all the cases; the distributed belief relation is not serial:

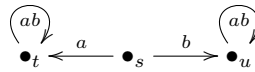

- (d) The following KB model is a counter-example; the distributed belief relation is not serial:

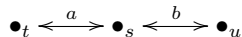

2. Follows from [6, Prop. 6]<sup>5</sup>.  
 3. (a) Consider the following S5 counterexample with two agents (which is also a counterexample for weaker logics):

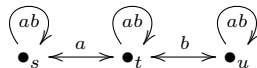

This frame is transitive, however,  $sR_{\{a,b\}}^E t$  and  $tR_{\{a,b\}}^E u$  but not  $sR_{\{a,b\}}^E u$ .

- (b) The common belief relation is transitive by definition. For distributed belief, assume that  $sR_G^D t$  and  $tR_G^D u$ . That means that  $sR_a t$  for every  $a \in G$  and that  $tR_a u$  for every  $a \in G$ ; which again means that  $sR_a u$  for every  $a \in G$  by transitivity of the individual relations and thus that  $sR_G^D u$ .
4. The cases for general and distributed belief follow from [6, Prop. 8]<sup>6</sup>.  
 5. (a) Follows from the same counter-example as in the case of transitivity.  
 (b) Let the individual relations be symmetric and Euclidean, and let  $sR_G^C t$  and  $sR_G^C u$ . Since there is a  $G$ -path from  $s$  to  $t$  and all relations are symmetric, there is a  $G$ -path from  $t$  to  $s$  and thus  $tR_G^C s$ . By transitivity of  $R_G^C$ ,  $tR_G^C u$ .  
 (c) The KD45 counter-model in the case for seriality works as a counter-model in this case as well: we have that  $sR_{\{a,b\}}^C t$  and  $sR_{\{a,b\}}^C u$  but not  $tR_{\{a,b\}}^C u$ .  
 (d) Let the individual relations be Euclidean, and let  $sR_G^D t$  and  $sR_G^D u$ . That means that  $sR_a t$  and  $sR_a u$  for any  $a \in G$ , and thus by Euclidicity of  $R_a$  that  $tR_a u$  for any  $a \in G$ . But that means that  $tR_G^D u$ .

Note that Lemma 1 implies preservation of certain combinations of properties. For example, while Euclidicity is not preserved for common belief on the class of all models, the combination of Euclidicity and symmetry is.

From these preservation results we can deduce (the lack of) properties of group belief operators, under different assumptions about the properties of individual belief. In addition to *preservation*, sometimes group belief gets *new* properties; e.g., common belief is always transitive by definition. The results are shown in Table 2 and illustrated in Figure 1.

We leave a discussion of most of these results to Section 5, but let us point to one in particular here: that seriality is not preserved for distributed belief on KD45. This has caused some confusion; for example is an axiomatization of KD45 with distributed belief given in [8] not sound. In the next section we correct that result.

<sup>5</sup> In the terminology of [6], general, common and distributed belief all correspond to *unanimous aggregation rules*.

<sup>6</sup> In the terminology of [6], general and distributed belief all correspond to *neutral aggregation rules*.

**Table 2.** Frame conditions and their preservation for group belief operators. The column EB (for general belief) lists the maximal combination of properties (among  $\{l, r, t, s, e\}$ ) that  $R_G^E$  is guaranteed to satisfy for any  $G$  in any model with the frame conditions given in the same row. Similar conventions are used for the columns CB for common belief and DB for distributed belief. The column CBr is for the alternative definition of common belief using the reflexive transitive closure instead of just the transitive closure. **Bold** indicates that some frame condition(s) are not preserved.

Frame cond.	EB	CB	CBr	DB	Frame cond.	EB	CB	CBr	DB
K	K	K4	S4	K	S4	<b>T</b>	S4	S4	S4
D	D	KD4	S4	<b>K</b>	B	B	S5	S5	B
T	T	S4	S4	T	S5	<b>B</b>	S5	S5	S5
K4	<b>K</b>	K4	S4	K4	K4B	<b>KB</b>	K4B	S5	K4B
KB	KB	K4B	S5	KB	K45	<b>K</b>	<b>K4</b>	<b>S4</b>	K45
K5	<b>K</b>	<b>K4</b>	<b>S4</b>	K5	KD5	<b>KD</b>	<b>KD4</b>	<b>S4</b>	<b>K5</b>
KD4	<b>KD</b>	KD4	S4	<b>K4</b>	KDB	KDB	S5	S5	<b>KB</b>
KD45	<b>D</b>	<b>KD4</b>	<b>S4</b>	<b>K45</b>					

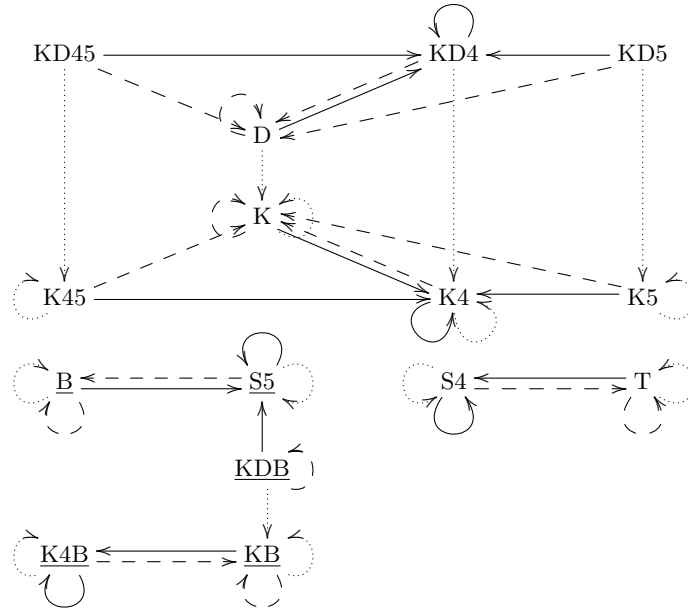

**Fig. 1.** Solid arrows represent common belief (transitive closure of the union), dashed arrows represent general belief (everybody-knows), and dotted arrows represent distributed belief. An arrow from one class to another means that group belief defined over individual belief having properties of the first class (i) has properties of the second class and (ii) does not have all the properties of any other of the classes we consider that strictly includes the second class. For example, distributed belief on KD45 is K45, and is not KD45 or KD4. For the alternative definition of common belief using the reflexive transitive closure, common belief is either S5 (underlined) or S4 (not underlined).



## 4 Axiomatization of $\text{KD45}^D$

An axiomatization of  $\text{KD45}$  with distributed belief is given in [8]. A completeness result is claimed, however without a proof. Furthermore, the axiomatization is in fact not sound, due to the issue mentioned at the end of the previous section (Theorem 3.4.1 (e) is incorrect)<sup>7</sup>: the consistency (D) axiom for distributed belief is not valid (in the class of  $\text{KD45}$  models). As far as we know, there is no detailed proof of completeness for axiomatizations of  $\text{KD45}$  with distributed belief in print. In this section we look into the  $\text{KD45}$  logic with distributed belief (i.e.,  $\text{KD45}^D$ , which is based on the language  $\mathcal{B}\mathcal{L}\mathcal{D}$ ), provide a (corrected) axiomatization for it, and present a detailed soundness and completeness proof.

The axiomatization for the logic  $\text{KD45}^D$  is given in Figure 2. It consists of a typical **KD45** proof system (with axioms PC, K, D, 4, 5, and rules MP and N) for individual belief, and a **K45** proof system (with axioms PC,  $\text{K}_D$ ,  $4_D$ ,  $5_D$ , and rules MP and  $\text{N}_D$ <sup>8</sup>) for distributed belief with additional axioms DB1 and DB2 characterizing the effect of group inclusion on distributed belief. The soundness of **BLD** is not hard to verify by Lemma 1 (or Table 2 for a quick reference). What remains is to show the completeness of **BLD**.

PC	all instances of tautologies	MP	from $\varphi$ infer $B_a\varphi$
K	$B_a(\varphi \rightarrow \psi) \rightarrow (B_a\varphi \rightarrow B_a\psi)$	D	$B_a\varphi \rightarrow \neg B_a\neg\varphi$
4	$B_a\varphi \rightarrow B_aB_a\varphi$	5	$\neg B_a \rightarrow B_a\neg B_a\varphi$
$\text{K}_D$	$D_G(\varphi \rightarrow \psi) \rightarrow (D_G\varphi \rightarrow D_G\psi)$	$4_D$	$D_G\varphi \rightarrow D_GD\varphi$
$5_D$	$\neg D_G \rightarrow D_G\neg D_G\varphi$	N	from $\varphi$ infer $B_a\varphi$
DB1	$D_{\{a\}}\varphi \leftrightarrow B_a\varphi$	DB2	$D_G\varphi \rightarrow D_{G'}\varphi$ if $G \subseteq G'$

**Fig. 2.** Axiomatization **BLD**, with  $\varphi, \psi \in \mathcal{B}\mathcal{L}\mathcal{D}$ ,  $a \in \text{AG}$  and  $G, G' \in \text{GR}$ .

In the presence of distributed belief operators, the typical canonical model definition for  $\text{KD45}^D$  does not give us a proper model, thus the method cannot be applied straightforwardly. We adapt the method of the completeness proof from [23] which can be traced back to [10, 14, 21]. The proof is presented in this way. We start in Section 4.1 by showing that **BLD** is sound and complete with respect to the class of all *pseudo*  $\text{KD45}$  models, in which distributed belief is treated as individual belief (i.e., in the operator  $D_G$ , the group  $G$  is treated as if it is an individual). Then, in Section 4.2, we define a translation between pseudo  $\text{KD45}$  models and (genuine)  $\text{KD45}$  models using the model construction methods of *unraveling* and *folding*. We show that the translation preserves truth of  $\text{KD45}^D$  in Section 4.3, which leads to the completeness of **BLD**.

<sup>7</sup> We refer here to the 1995 hardcover edition of [8]. The result appears to have been corrected in a later (2003) paperback edition; still without a proof of completeness however.

<sup>8</sup> The necessitation rule  $\text{N}_D$  for distributed belief, i.e., “from  $\varphi$  infer  $D_G\varphi$ ”, is provable via N, DB1 and DB2; hence omitted.

#### 4.1 Pseudo soundness and completeness

**Definition 4 (KD45 pre-model).** A KD45 pre-model (pre-model for short) for AG over PROP is a tuple  $M = (S, R, V)$  such that  $S$  is a domain and  $V$  is a valuation function defined as usual, while  $R : \text{AG} \cup \text{GR} \rightarrow \wp(S \times S)$  assigns to every single agent a KD45 relation (i.e., a serial, transitive and Euclidean relation) on  $S$ , and to every group of agents a K45 relation (i.e., a transitive and Euclidean relation) on  $S$ . A pointed pre-model is a pair consisting of a pre-model and a state of it.

A KD45 pre-model for AG over PROP can be seen as a model for  $\text{AG} \cup \text{GR}$  over PROP, where every individual is assigned a KD45 relation, and every group is treated similarly to an individual, but assigned a K45 relation.

Satisfaction at a pointed pre-model is therefore analogous to that at a pointed model. More precisely, given any pre-model  $M = (S, R, V)$  and  $s \in S$ ,

$$\begin{aligned}
(M, s) \models p & \quad \text{iff} \quad s \in V(p) \\
(M, s) \models \neg\varphi & \quad \text{iff} \quad \text{not } (M, s) \models \varphi \\
(M, s) \models (\varphi \wedge \psi) & \quad \text{iff} \quad (M, s) \models \varphi \text{ and } (M, s) \models \psi \\
(M, s) \models B_a\varphi & \quad \text{iff} \quad \text{for all } t \in S, \text{ if } sR_at \text{ then } (M, t) \models \varphi \\
(M, s) \models D_G\varphi & \quad \text{iff} \quad \text{for all } t \in S, \text{ if } sR_Gt \text{ then } (M, t) \models \varphi.
\end{aligned}$$

The only difference between the above and Definition 2 is in the interpretation of  $D_G\varphi$ , where for pre-models, we interpret using the preliminary  $R_G$  relation instead of  $R_G^D = \bigcap_{a \in G} R_a$ . In this sense,  $D_G$  operators behave similarly to a  $B_a$  operator. This is not, of course, sufficient – we want distributed and individual belief to have certain interaction properties. In particular we need to make the axiomatization **BLD** sound in the class of all semantic structures, but it is not the case at the moment, for the axioms DB1 and DB2 are not valid in the class of all pre-models. For this reason we define the notion of a *pseudo model*.

**Definition 5 (KD45 pseudo model).** A KD45 pseudo model (pseudo model for short)  $M = (S, R, V)$  is a pre-model such that

- $R_a = R_{\{a\}}$  for every agent  $a$ , and
- $R_{G'} \subseteq R_G$  for every  $G, G' \in \text{GR}$  such that  $G \subseteq G'$ .

It is not hard to see that **BLD** is sound with respect to the class of all pseudo models, for the KD45-ness of individual belief and K45-ness of distributed belief are required by definition of a pre-model, and DB1 and DB2 are fulfilled by the additional constraints for being a pseudo model.

We continue to show that **BLD** is also complete with respect to the class of all pseudo models. Later we shall show that any pseudo model is equivalent to a genuine model, so that the “pseudo” completeness result leads to a completeness result after all.

The *canonical pseudo model*  $M$  is a triple  $(S, R, V)$  such that:

- $S$  is the set of all maximal **BLD** consistent sets of  $\mathcal{BCD}$  formulas;<sup>9</sup>
- $R$  is such that for all  $\Phi, \Psi \in S$ ,
  - For all  $a \in \text{AG}$ ,  $\Phi R_a \Psi$  iff for all  $\varphi \in \mathcal{BCD}$ , if  $B_a \varphi \in \Phi$  then  $\varphi \in \Psi$ , and
  - For all  $G \in \text{GR}$ ,  $\Phi R_G \Psi$  iff for all  $\varphi \in \mathcal{BCD}$ , if  $D_G \varphi \in \Phi$  then  $\varphi \in \Psi$ ;
- $V$  is the valuation defined by  $V(p) = \{\Phi \in S \mid p \in \Phi\}$  for all  $p \in \text{PROP}$ .

It is not hard to verify that the canonical pseudo model is in indeed a pseudo model (in particular, one can check that  $R_a$  is a KD45 relation for any agent  $a$ ,  $R_G$  is a K45 relation for any group  $G$ , and the additional properties of pseudo models also hold for  $R_G$ ). The rest of the pseudo completeness proof goes just like a standard canonical model method (cf. [3]), and together with the pseudo soundness results argued above, we get the following.

**Lemma 2 (pseudo soundness and pseudo completeness).** *BLD is sound and strongly complete with respect to the class of all KD45 pseudo models.*

## 4.2 Translating a pseudo model to a model

As mentioned above, pseudo soundness and completeness is not sufficient – pseudo models are not proper models. For a proper completeness result we need to show that any consistent set of formulas has a proper model. What remains to do is to show that when a set of formulas has a pseudo model, it must also have a genuine model. We do this by introducing a truth-preserving translation from a pseudo model to a genuine model. In this section we introduce definitions of such a translation, with its truth-preservation shown in the next section.

To transform a pseudo model to a genuine model, we keep the same domain and valuation function, but redefine the uncertainty relation for every agent. We cannot just keep the uncertainty relation for each agent from the pseudo model and simply drop those for groups, for this will lead to a loss of uncertainty for groups which may finally make the resulting model not equivalent to the pseudo model. Technically speaking, in order to translate a pseudo model  $(S, R, V)$  to a genuine model  $(S, R', V)$ , we need to define what  $R'_a$  is for every agent  $a$ . By doing so we have to somehow merge the information for groups containing  $a$  into it. For example, by the definition of a pseudo model,  $R_{\{a,b,c\}}$  is a subset of  $R_{\{a\}} \cap R_{\{b\}} \cap R_{\{c\}} \cap R_{\{a,b\}} \cap R_{\{b,c\}} \cap R_{\{a,c\}}$  but not necessarily equal to the latter.<sup>10</sup> If we only keep the uncertainty relations for individuals, formulas such as  $D_{\{a,b\}}\varphi$  may have a different truth value before and after the translation.

We shall follow the method of *unraveling and folding* used in [23] which can be traced back to the early papers [10, 18, 14]. Yet we cannot simply reuse

<sup>9</sup> We refer to a modal logic textbook, say [3], for a definition of a (*maximal*) *consistent set of formulas*.

<sup>10</sup> The two must be equal in a genuine model, but we cannot simply define  $R_{\{a,b,c\}}$  to be the intersection of all of its subsets, for that already makes a pseudo model to be a genuine model. The whole method collapses then: we encounter the very problem that the canonical model is not a genuine model (mostly because the intersection of relations is not modally definable), which violates the starting point of the canonical model method. This was discussed in more detail already in [18].

all the definitions and lemmas there, as there are subtle differences due to the lack of reflexivity of the uncertainty relations. The following definitions and intermediate results are adaptations of similar constructs from the S5 case found in [23].

**Definition 6 (treelike pre-models).** *Given any pre-model  $M = (S, R, V)$ , a path of  $M$  from a state  $s_0$  to a state  $s_n$  is a finite non-empty sequence of the following form:*

$$\langle s_0, R_{\tau_0}, \dots, R_{\tau_{n-1}}, s_n \rangle$$

where each  $s_i$  ( $0 \leq i \leq n$ ) is a state in  $S$ , and each  $\tau_j$  ( $0 \leq j < n$ ) is either an agent or a group of agents such that  $s_j R_{\tau_j} s_{j+1}$  holds in  $M$ . Repetitions of states or relations are allowed in a path.

The reduction of a path is obtained by recursively replacing all of its segments of the type  $\langle x, R_{\tau}, y, R_{\tau}, z \rangle$  with  $\langle x, R_{\tau}, z \rangle$ . Note that the reduction of a path is unique, and is still a path, due to the transitivity of relations.

A reduced path is a path that is identical to its reduction. A pre-model  $M$  is called treelike, if for any two states  $s, t \in S$  there is at most one reduced path from  $s$  to  $t$ .

**Definition 7 (extensions and grafts).** *Let  $M = (S, R, V)$  be a pre-model, and  $\tau$  an agent or a group of agents. Let  $\vec{s}$  and  $\vec{t}$  be two paths of  $M$ .*

- $\vec{s}$  is called a  $\tau$ -extension of  $\vec{t}$  in  $M$ , if  $\vec{s}$  extends  $\vec{t}$  with  $\langle R_{\tau}, u \rangle$  for some  $u \in S$ ;
- $\vec{s}$  is called a  $\tau$ -graft of  $\vec{t}$  in  $M$ , if  $\vec{s}$  and  $\vec{t}$  are different  $\tau$ -extensions of the same path.

We illustrate the notions of a  $\tau$ -extension and a  $\tau$ -graft in Figure 3.



**Fig. 3.** Illustrations of a  $\tau$ -extension and a  $\tau$ -graft. For the graph on the left, the path below is a  $\tau$ -extension of the path on top, while for the graph on the right, the two paths are  $\tau$ -grafts of each other.

**Definition 8 (unraveling).** *Given a pre-model  $M = (S, R, V)$ , its unraveled structure  $M^u = (T, Q, \nu)$  is defined as follows:*

- $T$  is the set of all reduced paths of  $M$ ;
- Given  $\tau$  an agent or a group of agents, for any  $\vec{s}, \vec{t} \in T$ ,  $\vec{s} Q_{\tau} \vec{t}$  holds, iff

- $\vec{t}$  is a  $\tau$ -extension of  $\vec{s}$  in  $M$ , or
  - $\vec{s}$  is a  $\tau$ -graft of  $\vec{t}$  in  $M$ ;
- $\nu : \text{PROP} \rightarrow \wp(T)$  is such that for any  $s \in S$  and any  $\vec{s} \in T$  which ends with  $s$ ,  $\vec{s} \in \nu(p)$  iff  $s \in V(p)$ .

**Lemma 3.** *The unraveling of a pseudo model is a treelike pre-model.*

*Proof.* Given a pseudo model  $M = (S, R, V)$  and its unraveling  $M^u = (T, Q, \nu)$ , we must show all of the following properties:

1. for every  $a \in \text{AG}$ ,  $Q_a$  is serial, transitive and Euclidean;
2. for every  $G \in \text{GR}$ ,  $Q_G$  is transitive and Euclidean;
3. for all  $\vec{s}, \vec{t} \in T$  there is at most one reduced path of  $M^u$  from  $\vec{s}$  to  $\vec{t}$ .

We show these properties below.

1. Given  $a \in \text{AG}$  and  $\vec{s}, \vec{t}, \vec{u} \in T$  (i.e.,  $\vec{s}, \vec{t}, \vec{u}$  are reduced paths of  $M$ ),
  - Seriality. Suppose  $\vec{s} = \langle \vec{s}_0, R_b, x \rangle$  for some  $b \in \text{AG}$  and  $x \in S$ , i.e., the path that extends  $\vec{s}_0$  with  $\langle R_b, x \rangle$ . By the seriality of  $R_a$ , there exists  $y \in S$  such that  $xR_a y$ . Consider the path  $\vec{x} = \langle \vec{s}, R_a, y \rangle$ . By definition,  $\vec{x}$  is an  $a$ -extension of  $\vec{s}$  in  $M$ . A subtlety is that  $\vec{x}$  is a reduced path of  $M$  only when  $a \neq b$ . If  $a = b$ ,  $\vec{s} = \langle \vec{s}_0, R_a, x, R_a, y \rangle$ . Let  $\vec{y} = \langle \vec{s}_0, R_a, y \rangle$ , which is a reduction of  $\vec{x}$ . Clearly  $\vec{y}$  is an  $a$ -graph of  $\vec{s}$ . By the definition of unraveling,  $\vec{s} Q_a \vec{y}$ . This shows that there is a state of  $T$ , i.e.,  $\vec{x}$  or  $\vec{y}$ , that  $\vec{s}$  links to via  $Q_a$ ; hence the seriality of  $Q_a$ .
  - Transitivity. Suppose  $\vec{s} Q_a \vec{t}$  and  $\vec{t} Q_a \vec{u}$ . We must show  $\vec{s} Q_a \vec{u}$ . By the definition of  $Q_a$ , the supposition gives us four possible combinations of whether  $\vec{t}$  is an  $a$ -extension or  $a$ -graft of  $\vec{s}$ , and whether  $\vec{u}$  is an  $a$ -extension or  $a$ -graft of  $\vec{t}$ . By the definitions, it is not hard to verify that  $\vec{u}$  is either an  $a$ -extension or  $a$ -graft of  $\vec{s}$  (again, a subtlety is to enforce that  $\vec{s}, \vec{t}$  and  $\vec{u}$  are all reduced paths). Thus  $\vec{s} Q_a \vec{u}$ , as wanted.
  - Euclidicity. Suppose  $\vec{s} Q_a \vec{t}$  and  $\vec{s} Q_a \vec{u}$ . Similarly to the above, we have four possibilities, and we can show that  $\vec{t} Q_a \vec{u}$ .
2. The proof goes in the same way as in the case of individual belief. That  $Q_G$  lacks seriality is due to the lack of seriality of  $R_G$ .
3. Suppose there are two reduced paths (called *meta-paths* here) of  $M^u$  from  $\vec{s}$  to  $\vec{t}$ . The length of each meta-state (which is a path of  $M$ ) is non-decreasing along each meta-path. For a  $Q_\tau$  that comes from a  $\tau$ -extension, a different  $Q_{\tau'}$  leads to a different meta-state, with  $R_{\tau'}$  recorded in it. For a  $Q_\tau$  that comes from a  $\tau$ -graft, a different  $Q_{\tau'}$  also leads to a different meta-state. An observation here is that there is no way to revisit a meta-state in a reduced meta-path. The only way to keep the size of a meta-state (which is a path of  $M$ ) not growing is via a  $\tau$ -graph, but this cannot be made consecutively (otherwise not a reduced path). This guarantees the uniqueness of the reduced meta-path from  $\vec{s}$  to  $\vec{t}$ .

**Definition 9 (folding).** *Let  $M = (S, R, V)$  be a treelike pre-model.  $M^f$ , the folding of  $M$ , is the tuple  $(S, Q, V)$  such that for all agents  $a$ ,  $Q_a$  is the transitive and Euclidean closure of  $R_a \cup \bigcup_{G \ni a} R_G$ .*

Technically speaking, folding can be defined on any pre-model, but the name only makes sense for treelike pre-models, which is also revealed by Lemma 5.

**Proposition 1.** *Let  $(S, Q, V)$  be the folding of a treelike pre-model  $(S, R, V)$ . For every agent  $a$ ,  $Q_a$  is a KD45 (i.e., serial, transitive and Euclidean) relation.*

*Proof.* Seriality by that of  $R_a$ ; transitivity and Euclidicity by definition.

Applying the processes of unraveling and folding, we can translate a pseudo model into a genuine model. In the next subsection, we show the procedure of unraveling and folding is truth preserving.

### 4.3 Truth preservation of the translation

We introduce with necessary adaptations the notions of *trans-equivalence* and *trans-bisimulation* from [23], which are generalizations of modal equivalence and bisimulation that are relations over the set of (pointed) models to relations between a set of (pointed) models and a set of (pointed) pre-models.

**Definition 10 (trans-equivalence).** *Let  $(M, s)$  be a pointed model and  $(M', s')$  a pointed pre-model. We say  $(M, s)$  and  $(M', s')$  are trans-equivalent, denoted  $(M, s) \equiv^T (M', s')$ , if  $\{\varphi \mid (M, s) \models \varphi\} = \{\varphi \mid (M', s') \models \varphi\}$ .*

**Definition 11 (trans-bisimulation).** *Let  $M = (S, R, V)$  be a model and  $M' = (S', R', V')$  a pre-model. A non-empty binary relation  $Z \subseteq S \times S'$  is called a trans-bisimulation between  $M$  and  $M'$ , if the following hold for all  $s \in S$  and  $s' \in S'$  such that  $sZs'$ :*

- (Atom)  $s \in V(p)$  iff  $s' \in V'(p)$ , for all propositional variables  $p$ ;
- (Zig) for all  $G \in \text{GR}$  and  $t \in S$  such that  $sR_G^D t$ , there is a path of  $M'$  from  $s'$  to some  $t'$ , such that  $tZt'$  and all the edges in the path are of the form  $R'_\tau$  such that  $G \subseteq \tau$ ;
- (Zag) for all  $\tau \in \text{AG} \cup \text{GR}$  and  $t' \in S'$  such that  $s'R'_\tau t'$ , there is a state  $t \in S$  such that  $tZt'$  and  $sR_\tau t$  when  $\tau \in \text{AG}$  and  $sR_\tau^D t$  when  $\tau \in \text{GR}$ .

We write  $Z : (M, s) \rightleftarrows^T (M', s')$  if  $Z$  is a bisimulation between  $M$  and  $M'$  such that  $sZs'$ . Moreover,  $(M, s) \rightleftarrows^T (M', s')$  means that there is a  $Z \subseteq S \times S'$  such that  $Z : (M, s) \rightleftarrows^T (M', s')$ .

We shall also make use of the notion of a standard bisimulation (see e.g., [3]). For a distinction, the existence of a standard bisimulation is denoted by  $\rightleftarrows$ , and we use  $\rightleftarrows^T$  for trans-bisimulation.

**Lemma 4 (conditional invariance of trans-bisimulation).** *Given a pointed model  $(M, s)$  and a pointed pre-model  $(M', s')$ , if  $(M, s) \rightleftarrows^T (M', s')$  and there exists a pointed pseudo model  $(M'', s'')$  such that  $(M', s') \rightleftarrows (M'', s'')$ , then  $(M, s) \equiv^T (M', s')$ .*

*Proof.* Suppose  $Z : (M, s) \rightleftarrows^T (M', s')$  and  $Y : (M', s') \rightleftarrows (M'', s'')$ . We show that for any formula  $\psi$ ,  $(M', s') \models \psi$  iff  $(M, s) \models \psi$ . The proof can be carried out by induction on formulas. The only interesting cases are for  $B_a\varphi$  and  $D_G\varphi$ . Let  $M = (S, R, V)$ ,  $M' = (S', R', V')$  and  $M'' = (S'', R'', V'')$ .

The case for  $B_a\varphi$ . Sufficiency. Suppose  $(M, s) \models B_a\varphi$ , and we must show  $(M', s') \models B_a\varphi$ . For any state  $t' \in S'$  such that  $s'R'_at'$ , it suffices to show  $(M', t') \models \varphi$ . By (Zag) there is a state  $t \in S$  such that  $tZt'$  and  $sR_at$ . From  $(M, s) \models B_a\varphi$  it follows  $(M, t) \models \varphi$ . We get  $(M', t') \models \varphi$  by the induction hypothesis, as was to be shown.

For necessity, suppose  $(M', s') \models B_a\varphi$ , and we must show  $(M, s) \models B_a\varphi$ . Given any state  $t$  of  $M$  such that  $sR_at$  (equivalent to  $sR_{\{a\}}^D t$  as  $M$  is a model), it suffices to show  $(M, t) \models \varphi$ . By (Zig) there is a path of  $M'$  from  $s'$  to some  $t'$  such that (i)  $tZt'$  and (ii) every edge in the path is of the form  $R'_\tau$  with  $\{a\} \subseteq \tau$ . It follows from  $(M', s') \rightleftarrows (M'', s'')$  that there is a path of  $M''$  from  $s''$  to some  $t''$  such that (i)  $t'Yt''$  and (ii) every relation in the path is of the form  $R_\tau$  with  $\{a\} \subseteq \tau$ .  $s''R''_at''$  holds since  $M''$  is a pseudo model. Since we have  $(M'', s'') \models B_a\varphi$  by the invariance of bisimulation,  $(M'', t'') \models \varphi$  and so  $(M', t') \models \varphi$ . By the induction hypothesis we get  $(M, t) \models \varphi$ , as was to be shown.

The case for  $D_G\varphi$  can be shown analogously to the case for  $B_a\varphi$ .

**Lemma 5 (truthful translation).**

1. (Unraveling preserves bisimulation) Let  $M$  be a pseudo model and  $s$  a state of it. For any reduced path  $\vec{s}$  of  $M$  that ends with  $s$ ,  $(M, s) \rightleftarrows (M^u, \vec{s})$ .
2. (Folding preserves trans-bisimulation) Let  $M$  be a treelike pre-model and  $s$  a state of it. Then  $(M^f, s) \rightleftarrows^T (M, s)$ .

*Proof.* 1. It is not hard to verify that the conditions of (Atom), (Zig) and (Zag) for standard bisimulation are satisfied between a pointed model and its unravelling.

2. Let  $M = (S, R, V)$  be a treelike pre-model and  $M^f = (S, Q, V)$  its folding. It suffices to show that  $Z = \{(s, s) \mid s \in S\}$  is such that  $Z : (M^f, s) \rightleftarrows^T (M, s)$ . (Atom) holds trivially.

(Zig) Suppose there is a  $t \in S$  such that  $sQ_G^D t$  for some group  $G$ . It suffices to show that there is a path of  $M$  from  $s$  to  $t$  such that all the edges in the path are of the form  $R_\tau$  such that  $G \subseteq \tau$ . Suppose  $G = a_1, \dots, a_n$ , and then by definition we have  $Q_G^D = Q_{a_1} \cap \dots \cap Q_{a_n}$ , therefore  $(s, t)$  is in the transitive and Euclidean closure of  $R_{a_i} \cup \bigcup_{H \ni a_i} R_H$ , for all  $a_i$  with  $1 \leq i \leq n$ . It follows that there are  $n$  reduced paths of  $M$  from  $s$  to  $t$  such that:

$$\begin{aligned} &\langle s, R_{\tau_{1,1}}, \dots, R_{\tau_{1,m_1}} t \rangle \\ &\quad \vdots \\ &\langle s, R_{\tau_{n,1}}, \dots, R_{\tau_{n,m_n}} t \rangle \end{aligned}$$

where each  $\tau_{i,j}$  is either  $a_i$  or some  $H \ni a_i$ . Since  $M$  is treelike, there can only be a unique reduced path from  $s$  to  $t$ . It follows that (i)  $m_1 = m_2 = \dots = m_n$

(i.e., all possible reduced paths are of the same length; let us denote it by  $m$ ) and (ii)  $\tau_{1,j} = \tau_{2,j} = \dots = \tau_{n,j}$  (i.e., all relations remain the same at the same position of each possible reduced path; let us denote it by  $\tau_j$ ) for all possible  $j$ . But since  $\tau_{i,j}$  at least contains  $a_i$  (or is  $a_i$  itself), it follows that  $G \subseteq \tau_j$  for each  $j$ . Therefore,  $G \subseteq \tau_1 \cap \dots \cap \tau_m$ , as was to be shown.

(Zag) Suppose there is  $t \in S$  such that  $sR_\tau t$  for some agent or group  $\tau$ , and it suffices to show  $sQ_\tau t$  (if  $\tau$  is an agent) and  $sQ_\tau^D t$  (if  $\tau$  is a group). If  $\tau$  is an agent  $a$ , we get  $sQ_a t$  by the definition of  $Q_a$ . Otherwise  $\tau$  is a group  $G$  with  $sR_G t$ , and it follows from the definition of folding that  $sQ_x t$  for all  $x \in G$ , and thus  $sQ_G^D t$ .

**Theorem 1.** *BLD is a sound and strongly complete axiomatization of  $KD45^D$ .*

*Proof.* The soundness of **BLD** is easy to verify. As for the completeness, given a **BLD**-consistent set of  $\mathcal{B}\mathcal{L}\mathcal{D}$  formulas, it can be extended to a maximal consistent set  $\Phi$  of formulas using the standard Lindenbaum construction. By the pseudo completeness lemma (Lemma 2), there is a pseudo model  $(M, s)$  such that  $(M, s) \models \Phi$ . For any reduced path  $\vec{s}$  of  $M$ , it follows from Lemma 5 that  $(M^u, \vec{s}) \rightleftharpoons (M, s)$  and  $((M^u)^f, \vec{s}) \rightleftharpoons^T (M^u, \vec{s})$ , where  $M^u$  is the unraveling of  $M$  (which is a treelike pre-model by Lemma 3) and  $(M^u)^f$  is the folding of  $M^u$  (which is a genuine model by definition). By Lemma 4  $((M^u)^f, \vec{s}) \equiv^T (M^u, \vec{s})$ , and  $(M^u, \vec{s}) \equiv (M, s)$  by the known result of the invariance of standard bisimulation. Therefore,  $((M^u)^f, \vec{s}) \models \Phi$ .

## 5 Discussion

We have studied the properties of different types of group belief under different assumptions about the properties of belief (including knowledge). These are summed up in Figure 1. We emphasize that we have used standard definitions that are used for both group knowledge and group belief in the literature, in particular in the standard textbook [8].

We can make the, perhaps surprising, observation that many group attitudes to knowledge and belief used in the literature are not well defined in the sense that they do not actually have the properties it is assumed that knowledge or belief has. For example, general knowledge (everybody-knows) *is actually not knowledge*, and common belief or distributed belief *are most often not belief*. In particular:

- Under the standard assumption that knowledge has the S5 properties, what is sometimes called *general knowledge* or *mutual knowledge* in the literature, i.e., what everybody knows, is not actually knowledge. It is (KT)B but not S5, in particular it lacks both the positive and negative introspection properties.
- Under the assumption that belief is consistent (the D axiom) but not veridical (the T axiom), distributed belief is not actually belief (in any of the standard model classes). For example, distributed belief on  $KD45$  is  $K45$  but not



- KD45. We note that “D but not T” is an extremely weak assumption about belief, in fact a standard property distinguishing belief from knowledge.
- Under the common assumption that belief has the KD45 or just the K45 properties, then common belief is not actually belief. It is KD4 or K4, respectively, and not KD45 or K45. In general, common belief typically lacks negative introspection. More precisely, common belief loses negative introspection on any of the model classes without the B axiom (symmetry). If we take the reflexive transitive closure of the union instead of the transitive closure, common belief is S4 on both KD45 and K45 model classes, again lacking the negative introspection property.
  - General belief is not well defined as a notion of belief on weaker model classes than S5 either; it loses both positive and negative introspection on any class that has them.

*None* of the three (four, if we count the alternative definition for common belief) notions of group belief are actually belief on the most common model class for belief, namely KD45. The only cases for which all three notions of group belief are well defined in the sense that they have belief properties, are K, (K)T, KB and (KT)B.

Under the common assumption that belief does not have the veridicality property, the only cases where all three notions are well defined, in the sense that group belief actually has the properties of belief, are K and KB – i.e., under very weak assumptions about the properties of belief. Thus, group belief, as defined in the literature, strictly speaking typically is not actually belief, except under very weak assumptions about what belief is.

We hope these observations might help clarify the properties of group belief and knowledge. There has been some confusion and missing details in the literature regarding group knowledge/belief in general and distributed knowledge/belief in particular, for example about what the empty group knows [1] or what distributed knowledge actually means [2] – and about soundness and completeness of axiomatizations of KD45 with distributed belief. In this paper we provided a detailed completeness proof for a sound axiomatization of KD45 with distributed belief, by adapting a technique used for the S5 case in [23] to the KD45 case.

It should also be noted that while group belief often has fewer properties than individual belief (like common or distributed belief on KD45 as mentioned above), sometimes it has *more* properties. For example, common belief on KDB is S5 – it gains both positive and negative introspection. The alternative definition of common belief using the reflexive transitive closure is in a way “better behaved”; it is always either S4 or S5. However, its requirement that common belief must imply truth (reflexivity) does not square well with standard assumptions about belief (indeed, while this definition is often found for group knowledge, it is rarely found for group belief for weaker variants of belief than S5).

A conceptually closely related work is by Endriss and Grandi on *graph aggregation* [6]; the aggregation of one graph for each agent over the same set of vertices into a collective graph over the same set, in the spirit of aggregation

problems in social choice theory. Endriss and Grandi argue that this abstraction captures many concrete natural problems, including preference aggregation, social networks, and indeed group knowledge including general, common and distributed knowledge (belief is not mentioned explicitly but the argument does not rely on any particular properties of knowledge). And indeed, what we have called preservation of belief properties for different types of group belief in this paper, is exactly the same that [6] calls *collective rationality* of the corresponding aggregation rules with respect to the properties. Despite the close connection to the framework, we were only able to make use of some minor results from [6], in the proof of Lemma 1, as [6] focuses mostly on Arrow-style *impossibility* results.

The motivation behind this paper has been to take a critical look at *standard* definitions of group knowledge and belief in the literature; i.e., the interpretation of general, common and distributed knowledge and belief using union, transitive closure of union, and intersection of individual accessibility relations, respectively. These definitions appear in standard textbooks and in a myriad of other works, and understanding them is therefore important. Of course, other, perhaps less well known, formalizations of group belief exist, although they have not been the topic of the current paper. Of particular mention here is [11], which takes a critical look at different definitions of group belief from a philosophical perspective, and proposes some new formalizations in modal logic. An interesting direction for future work would be to investigate preservation of belief properties under different assumptions of individual belief, for other non-standard notions of group belief. More broadly, by using the impossibility results from [6] mentioned above, it might be possible to say something about the *impossibility* of other group belief operators under certain assumptions about belief.

**Acknowledgments** We thank the anonymous reviewers for useful comments. Yi N. Wáng acknowledges funding support by the National Social Science Foundation of China (Grant No. 16CZX048, 18ZDA290).

## References

1. Ågotnes, T.: What no one knows. In: 10th Conference on Logic and the Foundations of Game and Decision Theory (LOFT 2012). Sevilla (June 2012)
2. Ågotnes, T., Wáng, Y.N.: Resolving distributed knowledge. *Artificial Intelligence* **252**, 1 – 21 (2017)
3. Blackburn, P., de Rijke, M., Venema, Y.: *Modal Logic*, Cambridge Tracts in Theoretical Computer Science, vol. 53. Cambridge University Press, Cambridge University Press (2001)
4. van Ditmarsch, H., van der Hoek, W., Kooi, B.: Concurrent dynamic epistemic logic. In: Hendricks, V., Jørgensen, K., Pedersen, S. (eds.) *Knowledge Contributors*, pp. 105–143. Synthese Library Series, Kluwer Academic Publishers (2003)
5. van Ditmarsch, H., van der Hoek, W., Kooi, B.: *Dynamic Epistemic Logic*, Synthese Library, vol. 337. Springer (2007)
6. Endriss, U., Grandi, U.: Graph aggregation. *Artificial Intelligence* **245**, 86–114 (2017)

7. Fagin, R., Halpern, J.Y.: Reasoning about knowledge and probability. *J. ACM* **41**, 340–367 (1994)
8. Fagin, R., Halpern, J.Y., Moses, Y., Vardi, M.Y.: Reasoning about Knowledge. Cambridge, MA: The MIT Press (1995), hardcover edition
9. Fagin, R., Halpern, J.Y., Moses, Y., Vardi, M.Y.: Common knowledge revisited. *Annals of Pure and Applied Logic* **96**(1-3), 89 – 105 (1999)
10. Fagin, R., Halpern, J.Y., Vardi, M.Y.: What can machines know? on the properties of knowledge in distributed systems. *Journal of the ACM* **39**(2), 328–376 (Apr 1992)
11. Gaudou, B., Herzig, A., Longin, D., Lorini, E.: On modal logics of group belief. In: *The Cognitive Foundations of Group Attitudes and Social Interaction*, pp. 75–106. Springer (2015)
12. Halpern, J.Y.: Using reasoning about knowledge to analyze distributed systems. *Annual Review of Computer Science* **2**, 37–68 (1987)
13. Halpern, J.Y., Moses, Y.: Knowledge and common knowledge in a distributed environment. *J. ACM* **37**(3) (1990)
14. Halpern, J.Y., Moses, Y.: A guide to completeness and complexity for modal logics of knowledge and belief. *Artificial Intelligence* **54**, 319–379 (1992)
15. Halpern, J.Y., Fagin, R.: Modelling knowledge and action in distributed systems. *Distributed Computing* **3**, 159–177 (1989)
16. Halpern, J.Y., Moses, Y., Waalrts, O.: A characterization of eventual byzantine agreement. In: *Proceedings of the ninth annual ACM symposium on Principles of distributed computing*. pp. 333–346. PODC '90, ACM, New York, NY, USA (1990)
17. Halpern, J.Y., Tuttle, M.R.: Knowledge, probability, and adversaries. *J. ACM* **40**, 917–960 (1993)
18. van der Hoek, W., Meyer, J.J.C.: Making some issues of implicit knowledge explicit. *International Journal of Foundations of Computer Science* **3**(2), 193–224 (1992)
19. Jamroga, W., van der Hoek, W.: Agents that know how to play. *Fundam. Inf.* **63**(2-3), 185–219 (Apr 2004)
20. Meyer, J.J.C., van der Hoek, W.: *Epistemic Logic for AI and Computer Science*. Cambridge University Press, Cambridge, England (1995)
21. van der Hoek, W., Meyer, J.J.: Making some issues of implicit knowledge explicit. *International Journal of Foundations of Computer Science* **3**(2), 193–224 (1992)
22. Walther, D.: Satisfiability of atel with common and distributed knowledge is exptime-complete. Tech. rep., University of Liverpool (2005)
23. Wáng, Y.N., Ågotnes, T.: Public announcement logic with distributed knowledge: Expressivity, completeness and complexity. *Synthese* **190**(1 supplement), 135–162 (2013)