

# Sustainable Waste Management: The dynamics of Recycling of Municipal Solid Waste in Bergen, Norway

Master thesis in System Dynamics

Yana Balakina



Supervised by  
**Prof. Birgit Kopainsky**

System Dynamics Group  
Department of Geography  
University of Bergen

June 2019

## Acknowledgments

*I never could have imagined that I would be studying at a foreign university and I definitely didn't think my major would be System Dynamics. It completely changed the way I view the world and opened up many possibilities. The people who came into my life during these past two years were also a huge influence on me as an individual and broaden my horizons.*

*I would like to express my sincere gratitude to my supervisor, professor Birgit Kopainsky, who has been an incredibly kind and a guiding light in this difficult and important time. Thanks to her ability to find an approach to every single student, she encouraged me to have faith in myself and push my limits to work very hard on this project. Our weekly meetings*

*I would like to thank Toralf Igesund and Ingrid Hitland who are employees at BIR for their contribution, as well as my informants for their help in gathering necessary data for my project.*

*I want to express my appreciation to my seniors Anaely Aguiar and Billy Schoenberg, who were both very responsive, knowledgeable and kind, for sharing their experience and assistance along the way.*

*Last but not least, I would like to thank my family for their support.*

## Abstract

In the agreement with the UN's Sustainable Development Goal by 2030 sustainably reduce waste generation through recycling, reuse, and reduction of waste amounts Norway has set a target to increase material recycling up to 65 % by 2035.

The study aims to explore why the rate of material recycling is currently below the desired goal. A system dynamics model was developed to investigate the factors that affect recycling levels and find potential leverages that can be used to influence recycling behavior of citizens. The model includes waste generation phase, sorting behavior of the citizens driven by economic incentives and peer pressure as well as the waste management system in the municipality of Bergen, Norway. Several policies targeted to impact citizen's recycling performance have been analyzed.

The results show that garbage fee can be an effective instrument to promote material recycling of households' waste when combined with the well-organized sorting infrastructure, packaging design suitable for recycling and educational campaigns that enhance environmental awareness. The best policy outcome resulting in 34 % recycling rate by 2035 comes from the combination of even more eco-friendly packaging design, convenient sorting infrastructure and weight-based garbage fee system, whereas the less effective policy is the introduction of garbage fee alone.

## Table of Contents

Acknowledgments .....	1
Abstract .....	2
1. Introduction .....	4
2. Background .....	8
3. Method and modeling process.....	12
3.1 Methods of the study .....	12
3.2 Model description.....	13
Major assumptions .....	13
Model structure.....	13
The waste generation sector .....	14
The sorting sector .....	15
The waste management sector.....	17
4. Model testing and validation .....	21
4.1 Direct structure tests .....	21
4.2 Structure-oriented behavior tests.....	24
Extreme conditions behavior test .....	25
Behavior sensitivity .....	27
5. Behavior analysis .....	34
5.1 Base run.....	34
5.2 Scenario Analysis .....	38
6. Policy Analysis.....	43
7. Conclusion.....	55
List of Appendices.....	57
Appendix I: Model documentation.....	57
Appendix II: Interviews.....	77
Appendix III: List of figures .....	83
8. References .....	86

## 1. Introduction

This thesis is about sustainable waste management.

Waste has always been present in human societies - as long as there are societies and human activities, there will be waste. In our modern industrialized and post-industrialized mode of living, we are generating unprecedented amounts of waste, exceeding many ecosystems' capacity to render waste harmless. The World Bank estimates the annual waste generation increase by 70% from 2016 levels by 2050, due to population growth and urbanization (Kaza, 2018). With industrial development and increased consumption, waste has become a growing challenge causing major environmental issues.

Therefore, waste management needs to be not only smart and efficient but also sustainable. The primary objective of sustainable waste management is to ensure environmental, social and economic wellbeing implying that all the three are considered to be equally important.

Environmental sustainability in terms of waste management can be measured with the degree to which one is able to assimilate and treat the generated waste unable to be absorbed, in an environmentally friendly manner. The interpretation is consistent with the output/input rule, i.e., keep wastes within assimilative capacities and deplete non-renewables at the same rate renewable substitutes are developed, discussed by Goodland & Daly, where the authors proposed "... holding waste emissions within assimilative capacity without impairing it" (Goodland & Daly, 1996, p. 1002).

Moreover, since waste materials can be used as production inputs, recycling may be seen as a sustainable waste management strategy that does not place additional pressure on natural resources. At present on average 46 % (Eurostat, 2018, August 17) of the waste materials in the EU are being recycled back into production, creating a complete loop. This goes together with the concept of a circular economy that can sustain itself, not depending on external input.

The issues related to the waste generation and management are recognized by governments and NGOs alike. The UN's Sustainable Development Goal 12.5 addresses sustainable waste management, stating that "by 2030, sustainably reduce waste generation through prevention, reduction, reuse and recycling". In this context, the European Commission established a framework "to build a recycling society that avoided waste generation and used waste as a resource" (European Commission, 2016, June 09).

In waste management, the main methods of treatment are landfill, incineration, material recovery and reuse. These methods can be arranged in accordance with a waste hierarchy given the goal of environmental sustainability.

Recycling is a more desirable waste treatment method than for instance incineration or landfilling, because it enables to prolong material's lifecycles, and causes less environmental pollution if appropriately executed.

There are different types of waste and different sources of waste. In this thesis, the focus is on municipal solid waste. Municipal solid waste comes primarily from households, including household-like institutions, and contributes to 21 % of the total generated waste in Norway each year (Statistics Norway, 2019, April 3).

According to Norway's national targets in the environment area, the recycling rate of municipal waste has to increase up to 65 % by 2035 (European Commission, 2015).

For this thesis, I use the official target stated above as a foundation for the research problem.

Norway is a country with a highly developed waste management system, and one of the countries in the world with the highest rates of recycling. Despite this, the rate is still below the national target set by the EU. Figure 1 demonstrates the historical development (solid blue line) and the future trend (the red dashed line) of the recycling rate and the two targets. It could be seen that recycling has been maintaining approximately the same level for over a decade and does not seem to follow the projection made back in 2010.

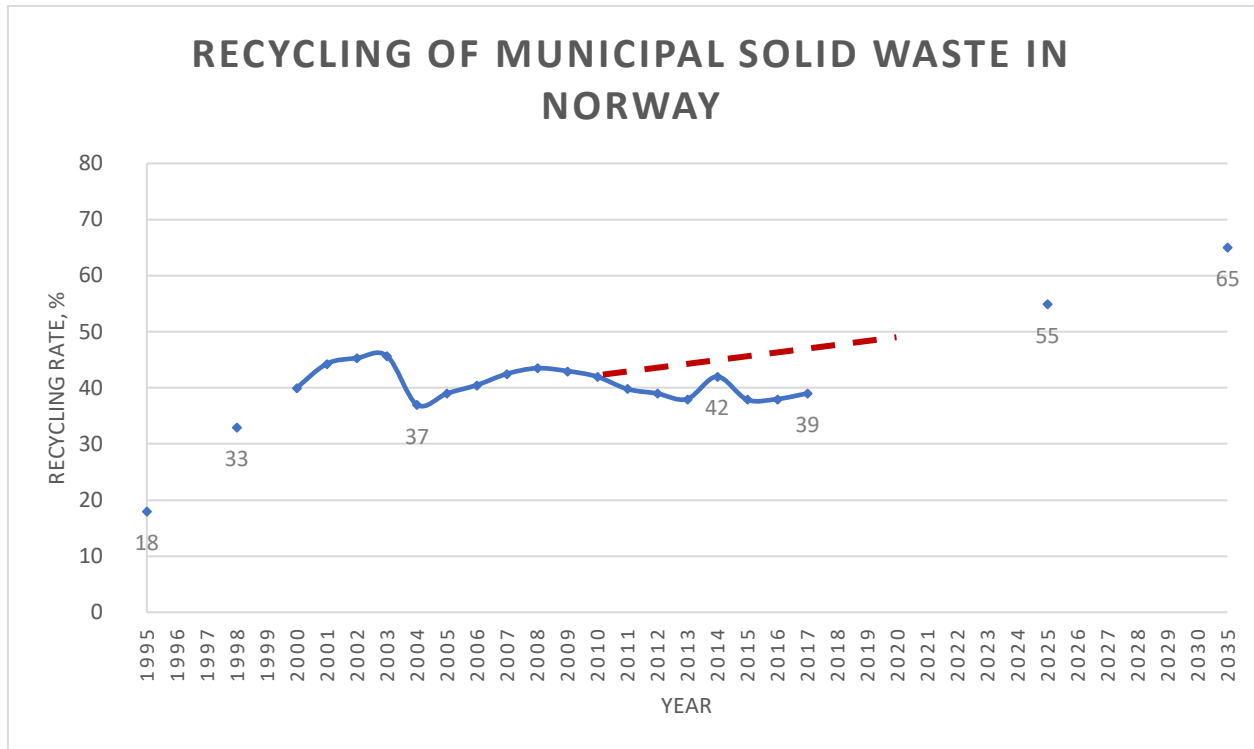
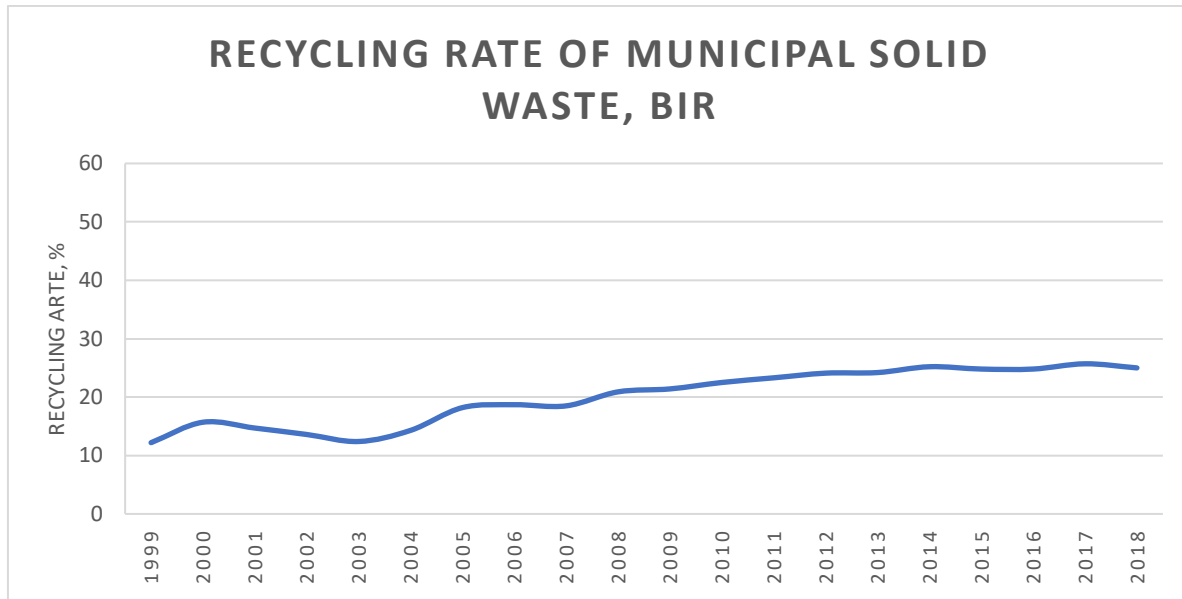

Figure 1: Historical and projected recycling rates of municipal solid waste in Norway (1995-2035)

A similar development is observed in the municipality of Bergen, where Norway's second largest waste management company Bergen district inter communal waste management company (BIR) handles the municipal waste. Figure 2 shows that recycling of household waste has stagnated at 25 %. Figure 1 and Figure 2 have different values for the recycling rate; figure 1 shows the average recycling rate for the country as a whole whereas figure 2 demonstrates the values for a waste management company.



*Figure 2: Recycling rate of municipal solid waste, BIR*

This study aims to explore why rate of material recycling is currently being below the desired goal of 65 %. To do so the following research questions have been posed:

Research question # 1: What are the factors that affect recycling levels?

Research question # 2: What are the potential leverages that can be used to influence recycling behavior of citizens?



## 2. Background

This section provides the theoretical background and context of the study.

Sustainable waste management has become a necessity as waste generation has been increasing with the population growth, making this topic widely discussed by a significant number of authors in literature.

Economic growth is seen as the main driving force behind waste volumes. Larger homes, higher housing standards, frequent decoration and reconstruction, and increased spending on furniture and household appliances are typical examples of how affluence generates waste (Norwegian Environment Agency, 2016)

In developed countries, waste treatment methods are usually more advanced than those in developing countries. It is argued that waste management systems based on proper legislation and policies can minimize environmental costs associated with poor waste treatment (Bala, Arshad, & Noh, 2017).

For instance, in countries like Germany, Denmark, Switzerland, with the world's most advanced waste management systems, landfilling of some types of waste is illegal or taxed. Introduction of such policies has forced the municipalities to find other ways of dealing with waste. Thus, a landfilled waste fraction is insignificant as compared to the other, more sustainable treatment methods, incineration, and recycling. A large number of studies compare the environmental, social and economic impacts of these methods.

For example, in the study on waste management methods and associated environmental impacts (Harrison et al., 2001) authors make a comprehensive assessment of the landfilling, composting, incineration, recycling and transportation of waste and their impact on air, water, soil, ecosystems and urban areas.

Recycling and incineration are seen as less harmful to the environment, if executed properly.

However, recycling is a more desirable method of waste treatment than energy recovery and disposal to landfill, as can be seen from the waste management hierarchy pyramid shown on the figure below (Recycling.com, 2012).

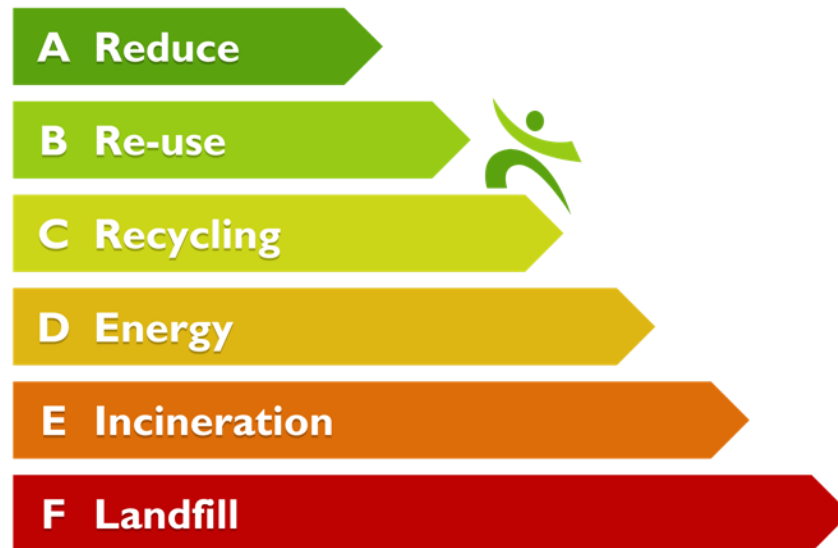

*Figure 3: Lansink's ladder*

It is so because recycling is the process of turning used products into raw materials that can be used to make new products, its purpose being conservation of natural resources and reduction of pollution. Recycling reduces energy consumption, since less energy is required to recycle a product than to make a new one. Similarly, recycling causes less pollution than manufacturing a new product and conserves raw materials. It also decreases the amount of waste sent to landfills or incinerators (Cleveland & Morris, 2006).

In their study Holmgren et al., claim that recycling and incineration are often viewed as competing activities but should instead be seen as complementary. This is so because once an incinerator plant is built the capacity should be fully utilized sometimes burning the materials that could otherwise be sent to material recovery. On the other hand, Ingrid Hitland, managing director at Bergen incinerator facility, pointed out that the highest recycling rates are found in the countries where waste incineration is also a widely used treatment method.

Municipal waste is divided into two categories combustible and non-combustible, then assigned a treatment method with regard to the two categories. A study of municipal waste from an energy perspective demonstrates that wastes such as paper and hard plastics, which can be both burned and recycled, are more suitable for recycling in terms of energy efficiency, and thus, should be sent to material recovery. On the other hand, cardboard and biodegradable waste should preferably be incinerated. Glass and metals are non-combustible wastes and should be recycled. Authors

conclude, that in order to improve overall recycling waste treatment methods should be chosen based on the waste categories (Holmgren, 2004).

According to EU data, Norway is a country with the highest energy recovery rates among the European countries. However, material recovery rate needs to be improved (Eurostat, 2018).

BIR, Norway's second largest waste management company is responsible for waste handling from approximately 360.000 inhabitants in the municipalities owning BIR. As of 2017, 60 % of the total municipal waste was incinerated, 20% was recycled, and about 20 % was landfilled (BIR, 2017).

Waste that has been sorted and collected is then transported to recycling. Residual waste is utilized for the production of energy and heat. The remaining waste that is unable to be recycled or incinerated, such as tires and concrete, is sent to landfills.

Incineration of municipal waste with energy recovery has become a standard option, and it is argued that solid waste has about one-third of the heating value of coal. Energy efficiency might be one of the reasons why incineration has been a priority treatment method after the introduction of landfill ban in combination with no incineration tax from 2010 (Kjær, 2013).

Alternative treatment methods of organic waste, such as composting and digestion, are not suited for the Bergen context, seeing as the demand for organic fertilizers is rather insignificant due to limited agricultural land in the area. Valerio (2010) points out that composting and digestion of organic waste are the better option only if there is a demand for the produced compost (Valerio, 2010).

Studies aiming to improve recycling investigate sorting behavior of citizens (Brekke, Kipperberg, & Nyborg, 2010), packaging design (Dace, Bazbauers, Berzina, & Davidsen, 2014), and markets for recycled. In the latter study, authors claim that in markets for secondary raw materials such as plastics limited demand and supply of quality materials causes the recycling for the material to remain low. The topics discussed above are out of the scope of this study.

While some materials are relatively easy to sort out and recycle, for instance aluminum or paper, thus making the circular economy work, other materials get recycled less due to their chemical complexity. Authors argue that recycling sectors for some materials, such as plastics, are underdeveloped due to organizational, technological and regulatory barriers (Milios et al., 2018).

Unsatisfactory conditions of waste that is collected and sorted for recycling decrease the amount of waste recycled. The better the quality of materials collected for recycling, the higher the fraction

of sorted and collected waste gets recycled. Information and education are necessary attributes in countries with high collection rates.

In addition to the quality of the sorted materials “...citizens participation is considered the touchstone for the success of any recycling scheme”. Participation is extremely critical for recycling “... even the sum of all the factors that improve recycling will not be sufficient if residents do not cooperate and separate their waste” (Dai et al., 2015).

Previous studies have shown that participation in any recycling program is greatly influenced by motivation. People who are concerned about the environment are motivated to recycle for internal reasons: recycling makes them feel like they are contributing to protecting the environment (Schultz, Oskamp, & Mainieri, 1995).

According to a study on household recycling behavior in Norway, both differentiated disposal fees and convenient recycling programs, such as curbside recycling and local drop-off centers, positively affect recycling levels (Halvorsen).

Literature review shows that waste management can be characterized as a complex system with feedback processes involved, hence system dynamics is a suitable methodology to use in this study. Finally, it may be concluded that the movement towards the circular economy and improvements in recycling rates greatly depend on the household's participation and provides the answer for the first research question.

### 3. Method and modeling process

#### 3.1 Methods of the study

In this thesis, I am using the methodology of System Dynamics (SD) in order to explain and analyze the dynamics of municipal solid waste management and by doing so find out why recycling rate remains below the national target. The approach I have chosen to use is relevant for studying causalities.

We can use the System Dynamics method in order to describe, simulate and analyze the time-dependent behavior of a system characterized by accumulation, feedback loops and non-linearity. To this end, I have made a SD model representing the waste management system of Norway's second largest waste management company, BIR.

To get the necessary qualitative and quantitative data to support the construction of the model structure I have reviewed relevant literature and complemented that with the interviews field experts working for BIR and households (see [Appendix II](#)). Statistical data for waste types and household's waste collected from Statistics Norway (SSB) and provided by BIR, were used in order to calibrate the model inputs.

To understand how the sorting structure works I used qualitative methods found in relevant scientific articles on household's sorting behavior. I also interviewed a number of local households to gather case-specific information about the motivation behind sorting waste and the knowledge of garbage fee system. For the list of questions to the interviewees see [Appendix II](#).

The data received was compared to the data acquired from the literature review and used to support the model structure.

Addressing the problem of municipal solid waste from the perspective of proper waste sorting might help in the development of good practice which both citizens and the government could benefit from.

## 3.2 Model description

This section includes explanation of the processes represented by the model structure, description of the model variables, causal relationships between them and the assumptions for parameter estimation.

In an attempt to understand the causes of why recycling rate remains stagnant and below the national target, the following model structure has been formulated. The time horizon of the model is 1999-2035. For the time period 1999 to 2018 there was data available showing the historical behavior, the period 2018 to 2035 is assumed to be a future projection of model behavior based on various scenarios. There are three different scenarios in the model.

### Major assumptions

Infrastructure for separate collection is well developed. Packaging design is presented by mostly eco-friendly packaging with the potential for improvement. There is no uncontrolled waste disposal.

### Model structure

There are 3 sectors in the model:

- ◆ the waste generation sector is a basic representation of the municipal waste generation given the varying local population size and the average amount of waste per person;
- ◆ the sorting sector is a simplified representation of the recycling behavior of the local citizens which is assumed to have an impact on material recycling;
- ◆ the waste management sector represents the mechanisms governing the stream of waste based on the waste type (sorted for recycling, residual waste for incineration or waste for disposal to a landfill).

## The waste generation sector

BIR is responsible for waste handling from approximately 360.000 inhabitants in the municipalities owning BIR (BIR, 2018).

The total number of inhabitants is based on the fractional population growth in the period from 1998 till 2018.

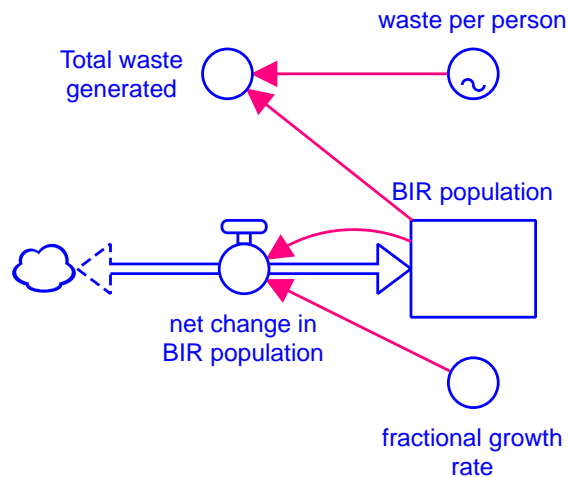

*Figure 4: a stock-and-flow diagram of the waste generation sector*

As population size and the annual waste generated per person grow so does the total amount of waste generated by households. According to the statistical data provided by BIR, each customer produces 420 kg of waste per year. Waste per person is influenced by economic factors such as GDP per capita and consumption levels and is considered to be exogenous in the model.

Future development of the total waste generated will be calculated based on different assumptions about the population size (growth, BAU, decrease) and about different assumptions regarding waste per person (faster growth, BAU, decrease).

## The sorting sector

As it was pointed out by (Ulli-Ber, Andersen, & Richardson, 2007, p. 739) the task of local authorities is «not only to manage the waste, but also to induce behavior change in the overall system». Conceptually, the sorting sector illustrates sorting behavior of the citizens and its ultimate purpose is to show to what extent sorting behavior can impact material recycling.

To encourage recycling municipalities might provide the citizens with the economic incentives to put out less trash by simply separating recyclables from residual waste. When sorting waste, the amount of residual waste decreases hence, the amount of recycled materials increases under a very important assumption, namely that waste is sorted properly. Another assumption is that households distinguish only between recyclables and residual waste. Recyclables mostly imply packaging waste made of plastics, glass, metals and cardboard.

Provided sufficient provision of services and information on recycling the great majority of the citizens in Bergen area are assumed to be sorters, i.e. most of them sort their waste, but some sort poorly. Poor sorting routing limits recycled fraction due to contamination of sorted out recyclables or simply due to the sorted-out amount of recyclables. For this reason, there are two stocks in the model.

The stock of *Adequate Sorters* represents the people which are concerned about the environment and sort their waste properly.

On the other hand, it is clear that not everyone recycles or does the job as they should, they are residents of the *Non-Adequate Sorters* stock. In order to find ways to convince *Non-Adequate Sorters* to recycle attention has turned more to the complexities of the many social and psychological determinants of recycling behavior (Thomas & Sharp, 2013).

There are various sources of motivation to sort waste such as intrinsic (people sort because it feels good and they care about the environment) and extrinsic (economic incentive and peer pressure). The latter two are used in the model to develop sorting habits.



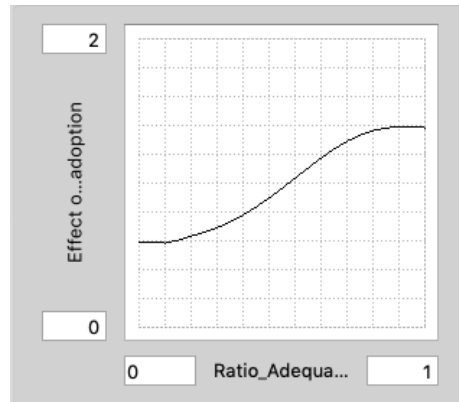

*Figure 5: effect of peer pressure on change in sorting behavior: the more adequate sorters the greater the peer pressure effect.*

In addition to economic incentives and peer pressure it is also assumed that change in recycling behavior is influenced by other behavioral effects such as *Household Cost* and convenience of recycling programs (here, *Packaging Design for Recycling* and recycling *Infrastructure*).

*Packaging Design for Recycling* implies that product packaging is as simple as possible which makes it easier for the households to recycle. Infrastructure availability provides an incentive to become an adequate sorter. This is so because availability of collection points and variety of containers for different recyclables reduce time cost of separating.

As the number of *Adequate Sorters* increases the influence of their behavior will impact *Non-Adequate Sorters*. Over time, more people will be sorting their waste because it is seen as a social norm. Despite the social norms and encouragement from peers, a small fraction of people will return to a previous state of being *Non-Adequate Sorters*.

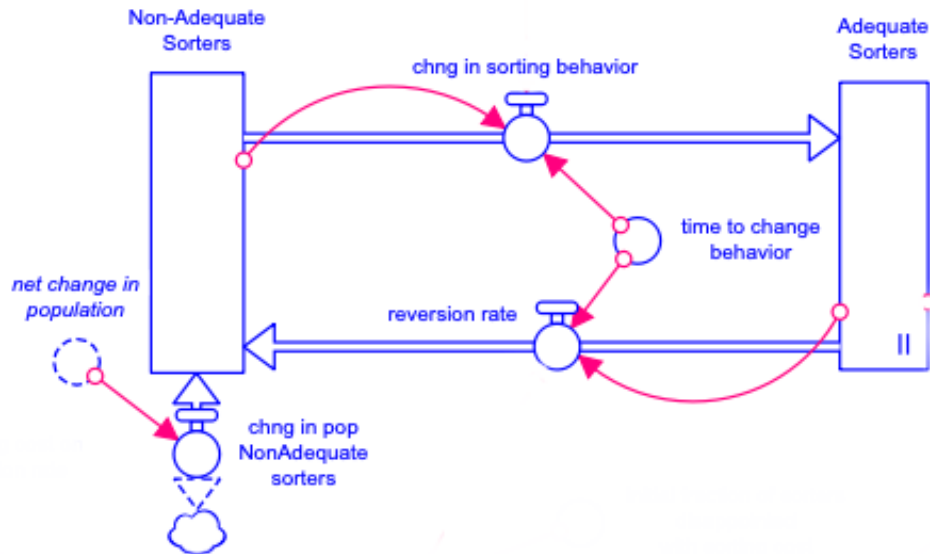

Figure 6: Recycling behavior

It is assumed that people's motivation is mostly driven by economic incentives and is used to stimulate household's participation in recycling programs which in turn lead to a reduction in the amount of generated waste and increased recycling (Thøgersen, 1994).

The economic incentive instrument is represented by a mix of flat rate and a volume-based fee. The calculation of the fee is based on the weight or volume of the delivered garbage, contrary to the flat-rate system creates an economic incentive to reduce the volume or the weight of the garbage. The elasticities of both the volume-based garbage fee and the weight-based garbage fee show the effects of price on garbage quantities. The magnitudes of the effects are found to be different and have been estimated based on the results of the case-study on the effects of unit-based garbage pricing in the municipalities of Denmark (A. Allers & Hoeben, 2010) and then calibrated.

The waste management sector

The waste management sector represents the mechanisms governing the stream of waste after it is collected from the citizens.

BIR collects separated waste (residual waste, recyclables) from the citizens and allocates them to either a recycling plant, an incinerator plant or to a landfill. The choice of treatment method greatly depends on the waste type and its quality.

For the model simplicity the total waste generated is divided into two categories: residual waste and recyclables. Residual waste includes the following waste types, organic waste must be either incinerated or composted due to the ban on landfilling of biodegradable waste introduced in 2009. The idea is to reduce greenhouse gas emissions and also to use waste as a resource for energy production. Composting of organic waste on a large scale is not practiced in the Bergen area due to low demand for organic fertilizers.

The stock “*Waste-to energy facility*” accumulates flows of residual waste measured in tones per year.

Recyclable waste includes packaging waste: plastics, paper, glass and metals. EU puts more focus on material recycling rather than on energy recovery implying that more waste must be recycled. However, materials for recycling are limited to packaging waste due to the producer responsibility schemes which ensure the “safety” of their products. This means that more materials could in theory be recycled but are not because of the dangerous substances inside.

Residual waste analyses (BIR, 2017) show that there is a potential to increase sorting of metals and glass for recycling.

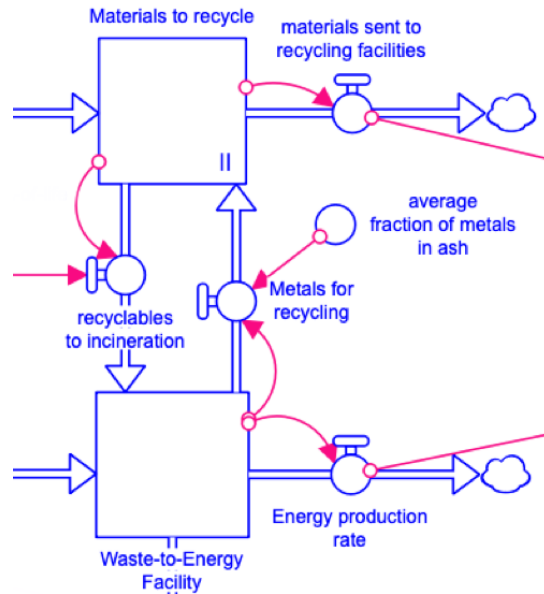

Figure 7: waste streams between incinerator plant and material recycling

Metals found in the bottom ash after combusting of residual waste is getting collected and sent to recycling. This process is represented by the outflow “*metals for recycling*”. The average fraction of metals collected from the bottom ash was estimated based on the statistical data provided by BIR and considered to be constant.

The output of the incinerator plant is energy. Since energy production process is out of the model boundaries the outflow “*energy production*” is defined in such a way that everything that gets combusted at the plant is turned into energy.

The stock “*Materials to recycle*” accumulates flows of materials such as paper, plastics, glass, metal, etc. It is assumed in the model that annually 5 % of all the collected recyclables are no longer suited for recycling due to their quality (end-of-life materials). Therefore, there is an outflow to the stock “*waste-to-energy facility*” (see figure 8 above). Materials delivered to the recycling facility are assumed to be treated once they leave the place. These materials are supposed to be used in the production of secondary materials.

The sock “*Landfill*” accumulates flows of hazardous waste, wastes that can be neither recycled nor incinerated and residuals from the incinerator plant expressed in tones per year. Shares of wastes delivered to landfill are the percentages of the total waste generated and are assumed to be

constant in the model. Data to estimate the shares was taken from the statistical data provided by BIR. Waste stays at the landfill for a very long time, thus the outflow is omitted.

The distribution of treatment method is shown by fractions of recycled materials to total waste generated and waste to energy to total waste generated. The variables are considered as the variables of the interest in the model since the purpose of the study is to explain possible causes of low recycling rate.

This aggregated causal loop diagram (CLD) gives an overview of the model variables and causal relationships between them.

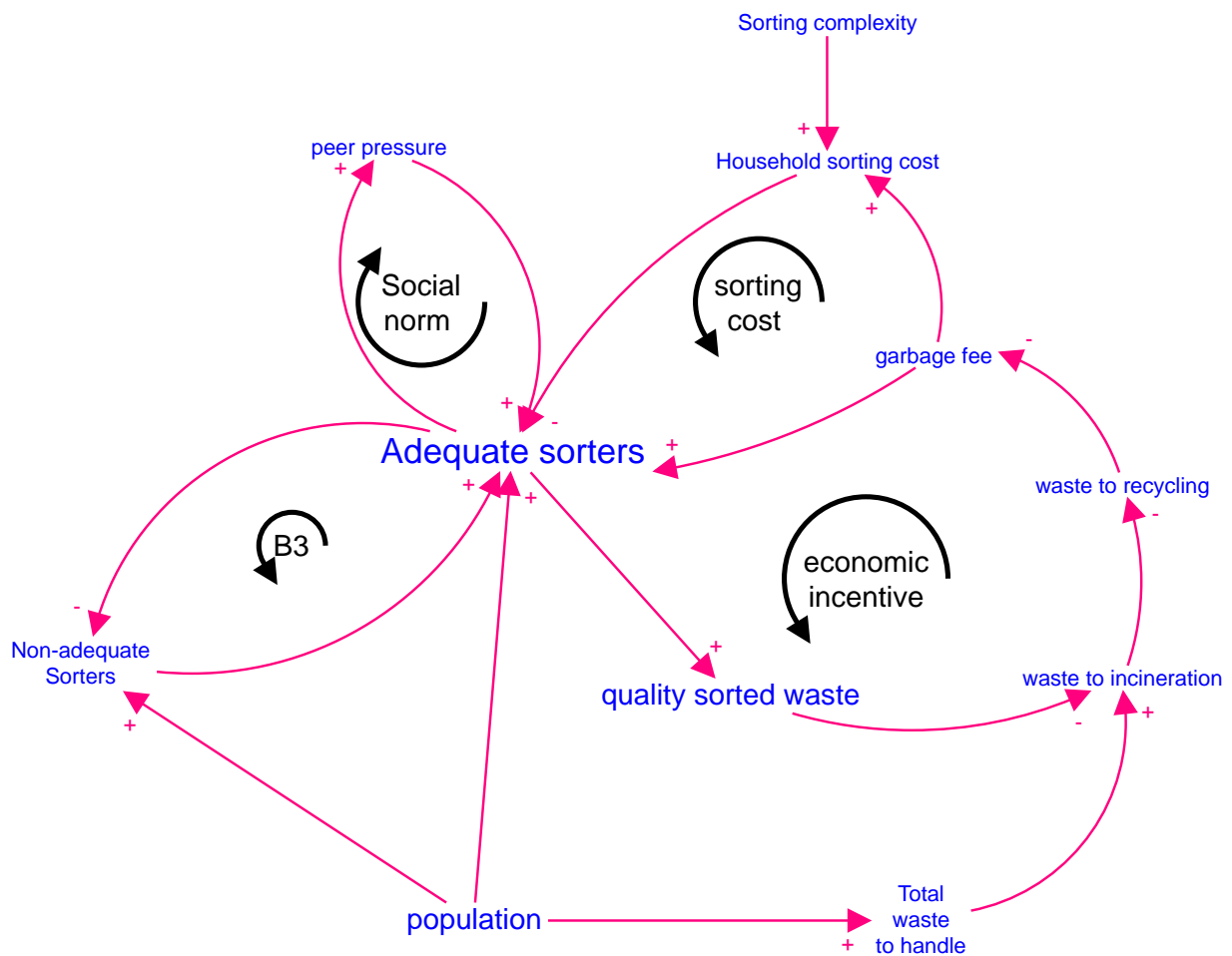

Figure 8: CLD

In this CLD there are three balancing loops and one reinforcing loop. The loop interplay shows that economic incentives positively affect household's participation in recycling programs which in turn lead to a reduction in the amount of incinerated waste and increased recycling. Sorting complexity makes recycling less convenient and more costly for the households and thus, creates policy resistance loop.

#### 4. Model testing and validation

Model validation is performed in order to build confidence in a model's behavior and results.

According to Barlas, the ultimate objective of system dynamics model validation is to establish the validity of the structure of the model by first testing the model structure and when sufficient confidence is built start testing the behavior accuracy (Barlas, 1996).

The following tests have been used to validate the model structure:

##### 4.1 Direct structure tests

This involves taking each mathematical equation or any form of logical relationship and comparing with their real-world knowledge about the system (Barlas, 1996).

##### **Structure confirmation test:**

*Waste generation rate* is a product of the yearly amount of waste per person and the number of citizens in the municipalities and the relationship seems to be logical.

*Sorting rate* is defined as product of a number of citizens who recycle, the amount of recyclables separated from total waste and the equation seems to also make sense.

*Fraction of end-of-life materials* is defined as a fraction of poor-quality recyclables due to their long life which is affected by the change in the amount of sorted waste. Since recycling in the model is mostly limited by recycling of packaging waste and some materials can only be recycled a limited number of times the fraction of end-of-life materials should have been taken into account.

##### **Parameter confirmation test:**

The model structure used in the model is a product of both operating knowledge and the theoretical knowledge acquired from the peer reviewed scientific articles.

Some parameter values and initial values of the stocks are based on the statistical data provided by the waste management company (BIR). Where the initial values and parameter values could not be confirmed by the statistical data available, I used the calibration tool in Stella Software or in some cases my best judgement to estimate the parameters. These are listed in Table 1.

Name	Used for	Sources	Perceived accuracy
Adequate Sorters	input	Assumption based on interview	low
Non-Adequate Sorters	input	Assumption based on interview	low
Elasticity of volume-based garbage fee to the amount of residual waste	input	A. Allers, M., & Hoeben, C. (2010) <sup>1</sup>	medium
Normal fraction of end-of-life materials	input	N/A	low
Elasticity of sorted waste to end-of-life materials	input	N/A	low
Initial packaging design	calibration	N/A	low
Initial infrastructure factor	calibration	N/A	low
Initial sorting adoption fraction	calibration		medium
Elasticity of weight-based garbage fee to the amount of residual waste	input	A. Allers, M., & Hoeben, C. (2010)	medium
Elasticity of sorted waste on waste per person	input	N/A	low

---

<sup>1</sup>A. Allers, M., & Hoeben, C. (2010). Effects of Unit-Based Garbage Pricing: A Differences-in-Differences Approach. *Environmental and Resource Economics*, 45(3), 405-428. Retrieved from <https://doi.org/10.1007/s10640-009-9320-6>. doi:10.1007/s10640-009-9320-6

Elasticity of packaging design to sorting complexity	input	N/A	low
Elasticity of infrastructure to sorting complexity	input	N/A	low
Reference fractional growth rate	input	Statistical data (BIR)	medium
Average fraction of recyclables in total waste	input	(BIR, 2017)	medium
Elasticity of ratio of adequate sorters on fraction of quality sorted waste	calibration	N/A	low
Average normal garbage fee	input	Statistical data (BIR)	medium

*Table 1: Parameter confidence assessment*

The parameters are considered to be corresponding to real system both conceptually and numerically with acceptable degree of accuracy.

**Direct extreme condition tests:**

These tests ask whether model behaves appropriately when the inputs take on the extreme values (Sterman, 2000).

The test was performed both with and without simulating the model to see whether the model equations make sense under assumed extreme conditions.

The following variables are considered to be crucial for testing:

*Population* gets value zero. Outcome is zero generated waste, absence of sorters and thus, no sorted or landfilled waste.

*Waste to recycling* gets value zero. Outcome is zero recycling and waste gets incinerated instead.

During the model simulation minor flaws were revealed such as the outflow from the *Waste-to-energy facility* does not take a value of zero when the inflow to the stock is zero. Other than that, the test is passed.

**Boundary adequacy test:**

Ensures that the model serves its purpose which is to investigate why rate of material recycling is currently below the desired goal of 65 %. Figure 9 demonstrates the model boundary.



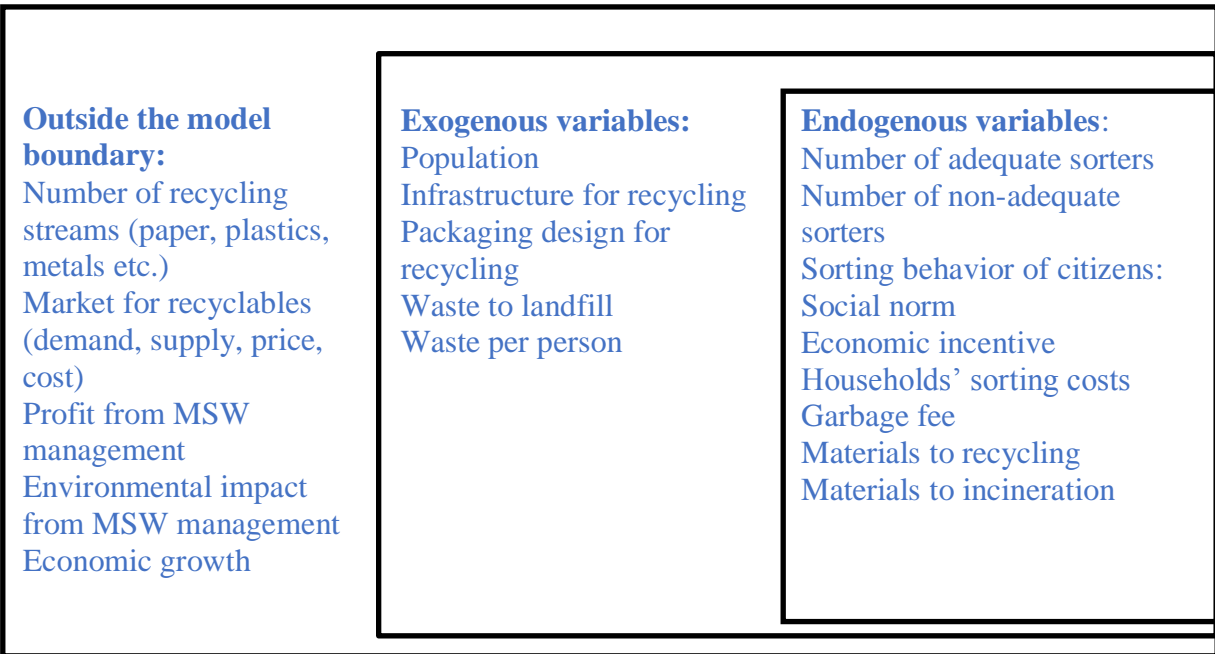

Figure 9: boundary chart

**Dimensional consistency test:**

Was performed throughout the model building process using the built-in tool in Stella Architect software. The tool allows to check the unit consistency between the variables.

**Integration error test:**

A time step chosen for the model is 0,25. It is a common knowledge that time step should be time smaller than the smallest time constant in the model which is 1 year. The results do not seem to be sensitive to the time step of choice, thus, the time step is accurate enough.

4.2 Structure-oriented behavior tests

The tests are used to test the structure by looking at the behavior and involve simulation.

### Extreme conditions behavior test

Have been performed to see how the model behaves under extreme conditions and whether the model behavior corresponds to the expected behavior of the real system. Variable “waste per person” has become the first candidate to analyze what will be the model outputs like if there was no waste produced by the citizens.

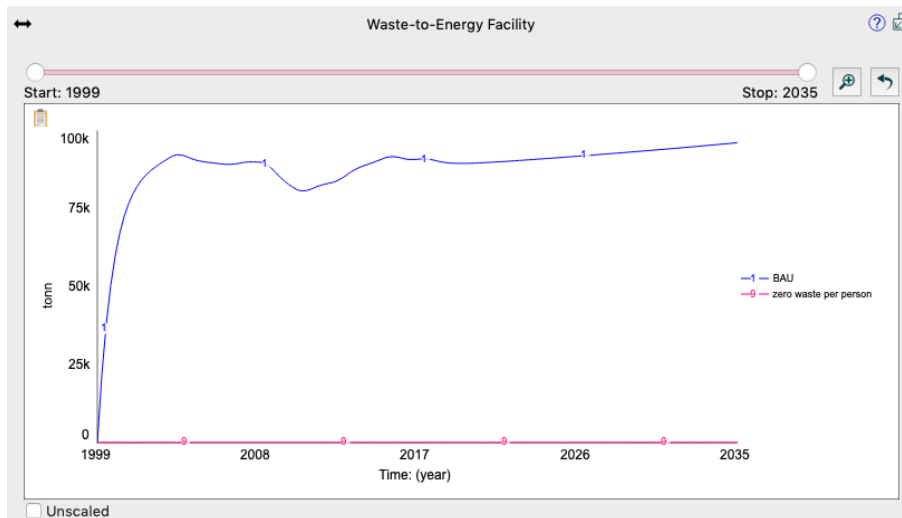

Figure 10: zero waste per person condition

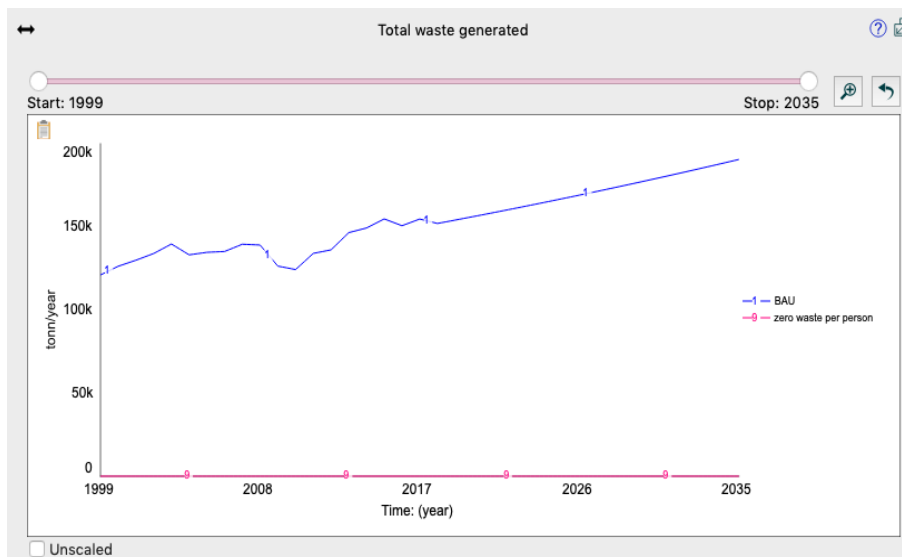

Figure 11: zero waste per person condition

The figures show the results for total waste generated and waste at the Waste-to-Energy facility at zero waste per person condition. The blue graph represents the BAU and the red graph represents the respective variable at the zero waste per person condition.

The results above show that at zero *waste per person* there will be no waste to handle by the waste management company. This is realistic with regards to the real-world expectations.

The following are the results for the *fraction of sorters disappointed with sorting costs = 1*. If this was the case, then all the *Adequate Sorters* would change their sorting habits and become *Non-Adequate Sorters* as it can be seen from the Figure 16 and Figure 17 respectively. The anticipated behavior matches the behavior produced by model simulation.

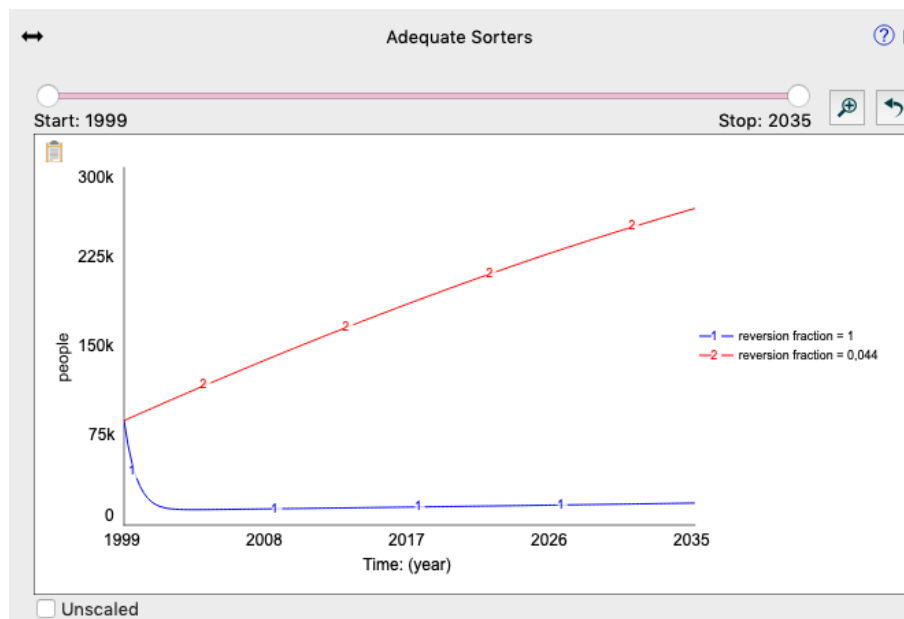

Figure 12: Behavior of Stock of Adequate sorters: reversion fraction = 1.

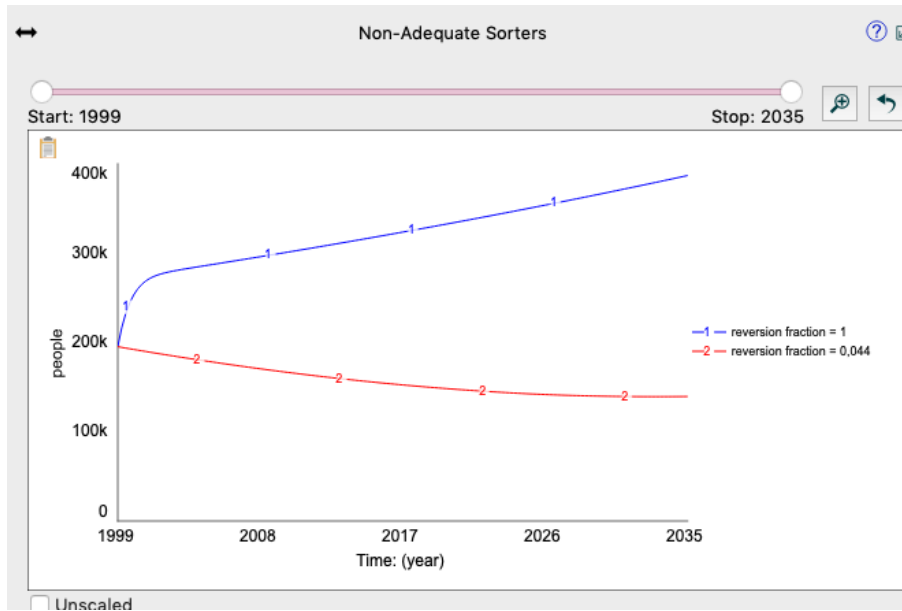

Figure 13: Behavior of Stock of Non- Adequate sorters: reversion fraction = 1.

### Behavior sensitivity

Allows to see how sensitive the model behavior is to relatively small changes of parameter values, initial values and graphical functions. Sensitivity analysis has been performed in order to identify variables that might produce uncertainties in the model.

The following model variables with the low level of accuracy (see Table 1) have been tested on sensitivity: *Non-Adequate Sorters (initial value)*, *Adequate Sorters (initial value)*, *Normal fraction of end-of-life materials*, *Elasticity of sorted waste to end-of-life materials*, *Elasticity of sorted waste on waste per person*, *Elasticity of packaging design to sorting complexity*, *Elasticity of infrastructure to sorting complexity*.

Non-Adequate Sorters (initial value)
0,05

0,15
0,25
0,35
0,55
0,65
0,75
(BAU value)

Table 2: “Non-Adequate Sorters “initial value” sensitivity test values

In the baseline scenario, *Non-Adequate Sorters initial value* is set to 0,75 based on assumption.

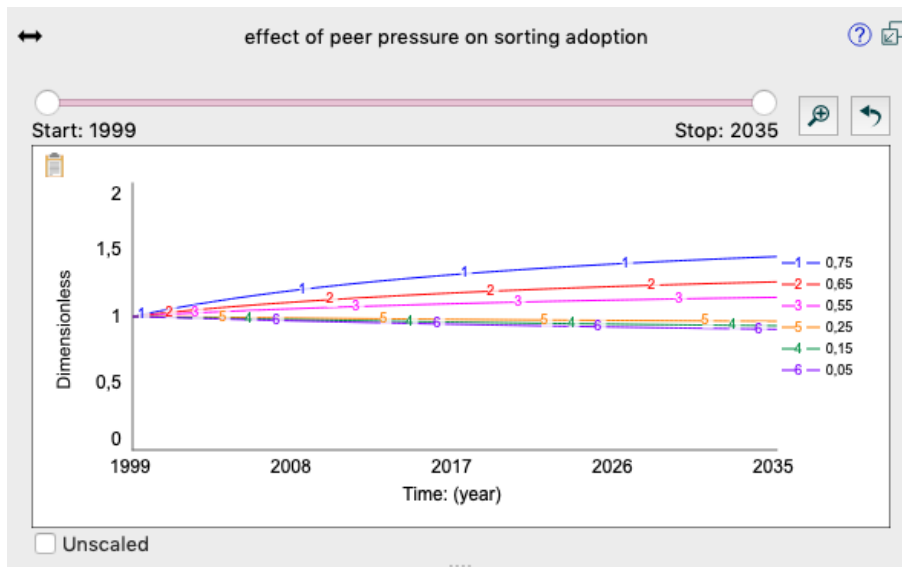

Figure 14: “Non-Adequate Sorters (initial value)” test for “effect of peer pressure on sorting adoption”

Figure 14 shows possible values for effect of peer pressure on sorting adoption based on different initial values of *Non-Adequate Sorters stock*. It can be seen that in instances when initial value takes value greater than 50 % the effect is more powerful then otherwise which makes sense.

**Normal fraction of end-of-life materials**

0
0,01
0,2
0,3
0,04 (BAU value)
0,5
0,6
0,7
0,8
1

Table 3: “Normal fraction of end-of-life materials” sensitivity test values

In the baseline scenario, Normal fraction of end-of-life materials value is set to 0,04 based on assumption.

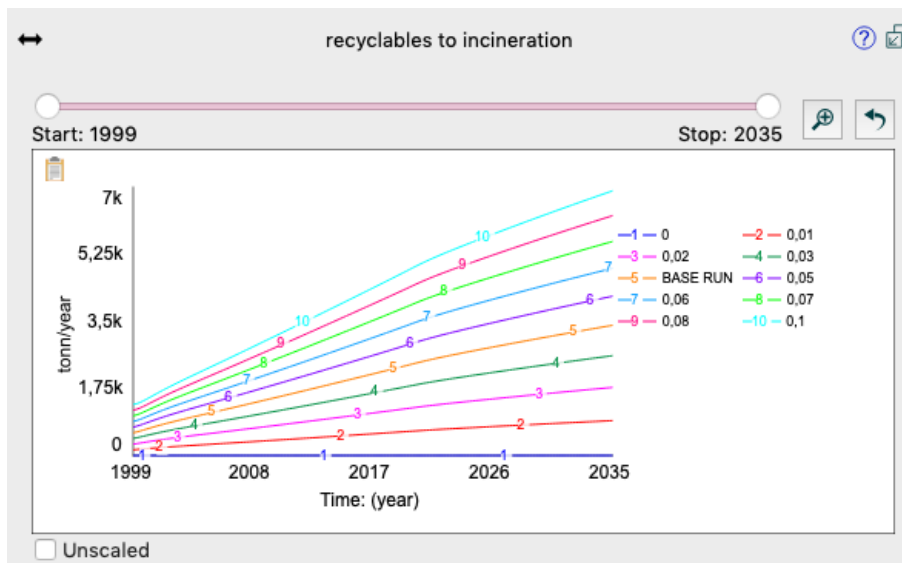

Figure 15: Sorted out recyclables to incineration sensitivity test for Normal fraction of end-of-life materials

Figure 15 shows that except for sensitivity of numerical values there are no major changes in behavior, so the model behavior is considered to be insensitive to changes in this parameter’ values.

Similar results are found for the *Elasticity of sorted waste to end-of-life materials* (Figure 15)

<b>Elasticity of sorted waste to end-of-life materials</b>
0
0,16
0,3
0,5 (BAU value)
0,6
0,8
1

Table 4: Elasticity of sorted waste to end-of-life materials *sensitivity test values*

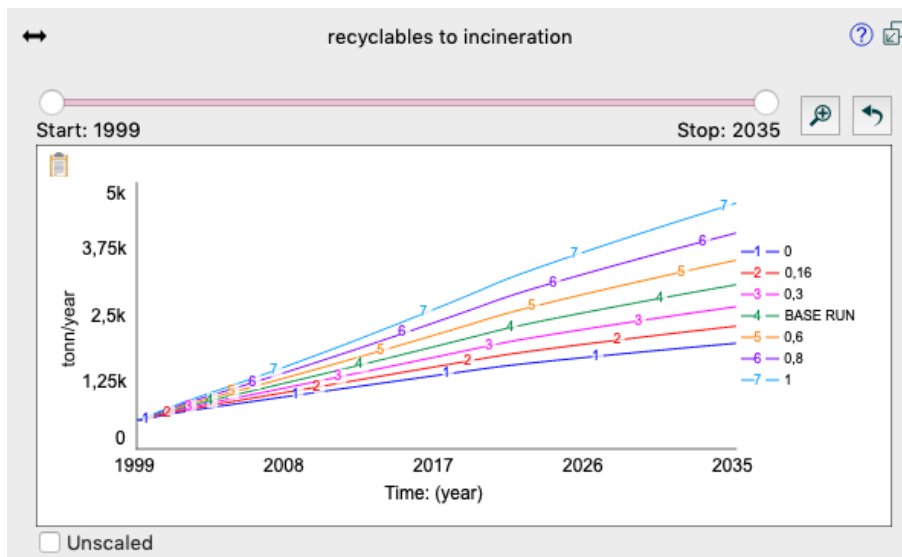

Figure 16: Sorted out recyclables to incineration sensitivity test for Elasticity of sorted waste to end-of-life materials

Figure 16 shows that except for sensitivity of numerical values there are no major changes in behavior, so the model behavior is considered to be insensitive to changes in this parameter' values.

<b>Elasticity of sorted waste on waste per person</b>
0
0,01(BAU value)
0,02
0,03
0,04
0,05
0,06
0,07
0,8
1

Table 5: “Elasticity of sorted waste on waste per person” sensitivity test values

In the baseline scenario, *Elasticity of sorted waste on waste per person* value is set to 0,01 based on the assumption.

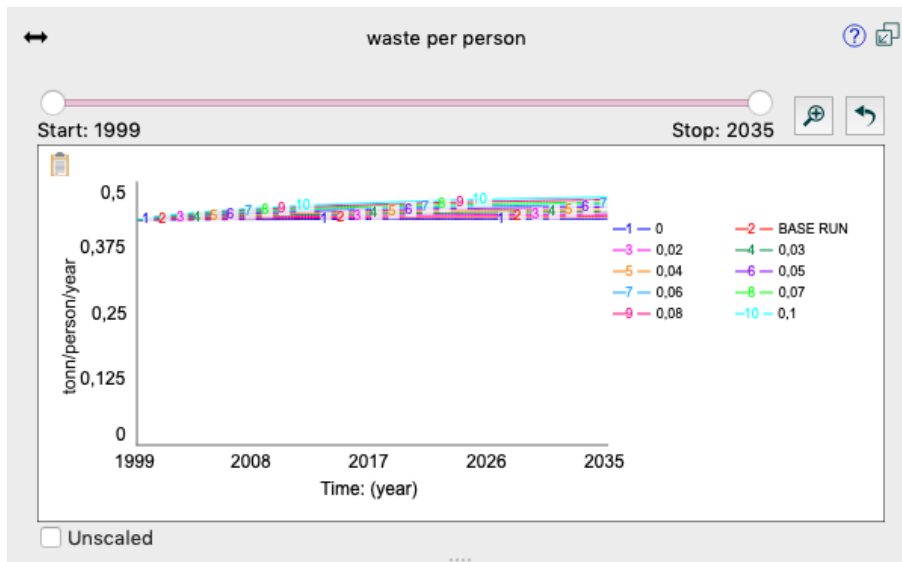

Figure 17: Waste per person sensitivity test for Elasticity of sorted waste on waste per person.

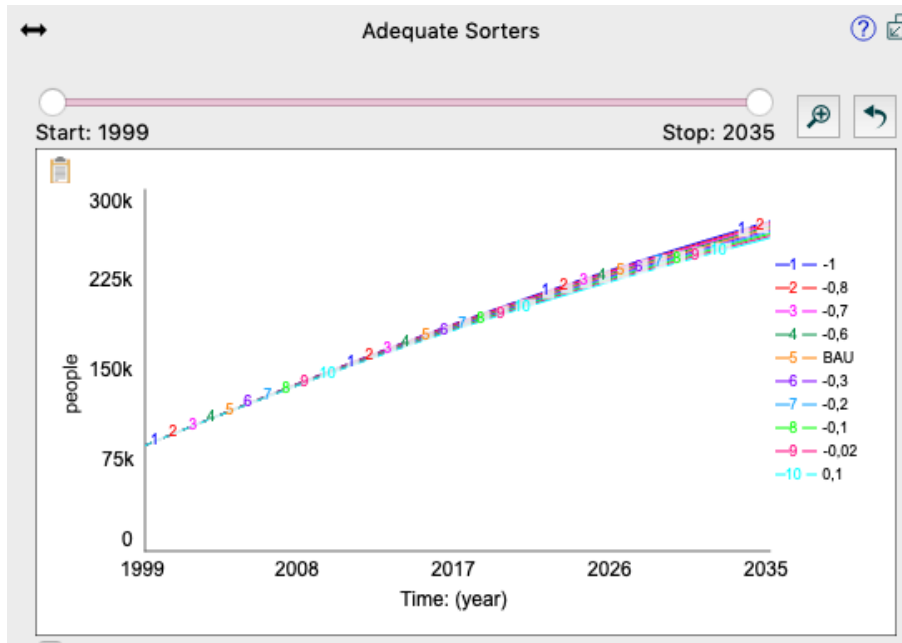

Figure 17 shows that except for sensitivity of numerical values there are no major changes in behavior, so the model behavior is considered to be insensitive to changes in this parameter' values.

<b>Elasticity of packaging design to sorting complexity</b>
-1
-0,8
-0,7
-0,6
-0,5 (BAU value)
-0,3
-0,2
-0,1
-0,02
0,1

*Table 6 : “Elasticity of packaging design to sorting complexity” sensitivity test values*

In the baseline scenario, *Elasticity of packaging design to sorting complexity* value is set to -0,5 based on assumption.



*Figure 18: Adequate sorters sensitivity test for elasticity of packaging design to sorting complexity*

Figure 18 shows that except for sensitivity of numerical values there are no changes in behavior, so the model behavior is considered to be insensitive to changes in this parameter's values.

Sensitivity analysis did not reveal any major changes in behavior modes, only in parameter values.

The model is found capable of reproducing the reference mode and also explaining how the behavior is generated.

Model validation process revealed that the model results are quite sensitive to the effects which represent behavioral processes, such as for example effect of peer pressure, effect of households' sorting costs on change in reversion rate, and effect of crowding on households' costs. Results the model produces are satisfactory for the purpose of this study. In order to test which policy is more robust and should be implemented building more confidence in the model's results is necessary and will require collection of more accurate data on the effect.

## 5. Behavior analysis

In this section the simulations resulting from the base run is analyzed. The simulation specifications are the following:

- Integration Method: Euler
- Time Unit: years
- Time Step: 0,25
- Time Horizon: 36 years

### 5.1 Base run

The base run corresponds to the historical development of the recycling rate and also shows the future development based on the following assumptions.

In the business-as-usual state population is assumed to grow from its initial value by 12 % by 2035 (Statistics Norway) and waste per person remains at the level 420 kg per person per year which is an average amount of waste per person in the reference period. As population size increases increasingly so does the total amount of waste.

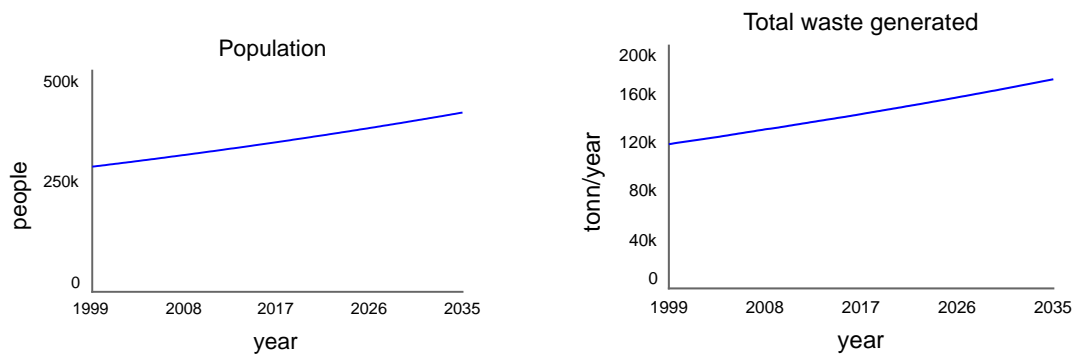

*Figure 19: base run: waste generation phase*

Total generated waste produced by households needs to be separated and delivered to BIR in the form of sorted materials prepared for treatment. The amounts of materials to be burned and recycled highly depend on quality of separation.

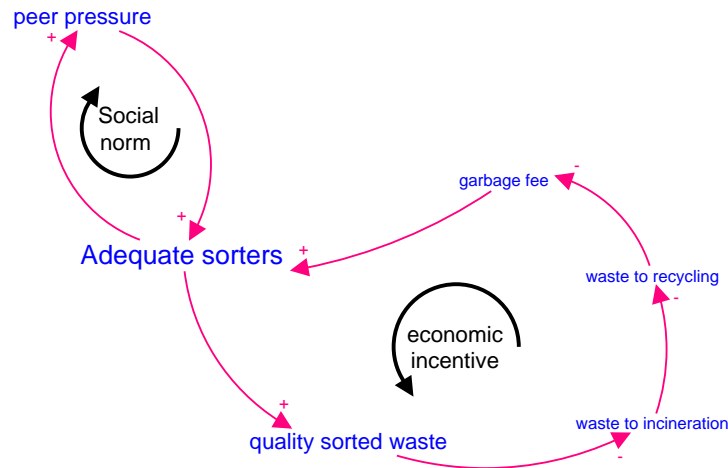

Figure 20: balancing loop (economic incentive) and reinforcing loop (social norm)

Although most of the BIR's customers can be characterized as duty-oriented in the beginning of the simulation more than half of the population (initial value of the Non-adequate sorters stock) have a potential to sort their waste better. Mostly, these are people who value the environment but need to be provided with either more information or incentives. These incentives are represented by the garbage fee as well as by the social norm i.e. peer pressure (see figure 20).

Initially, the reinforcing loop dominates so that sorters grow faster because of the impact of peer pressure. As the number of Adequate sorters increases, the impact of crowding becomes constraining. Eventually, the balancing loop becomes dominant and slows down the growth behavior in the stock of Adequate sorters. Since the behavior effects are quite sensitive in the model, the Adequate sorters will never be equal to the total population (figure 21).

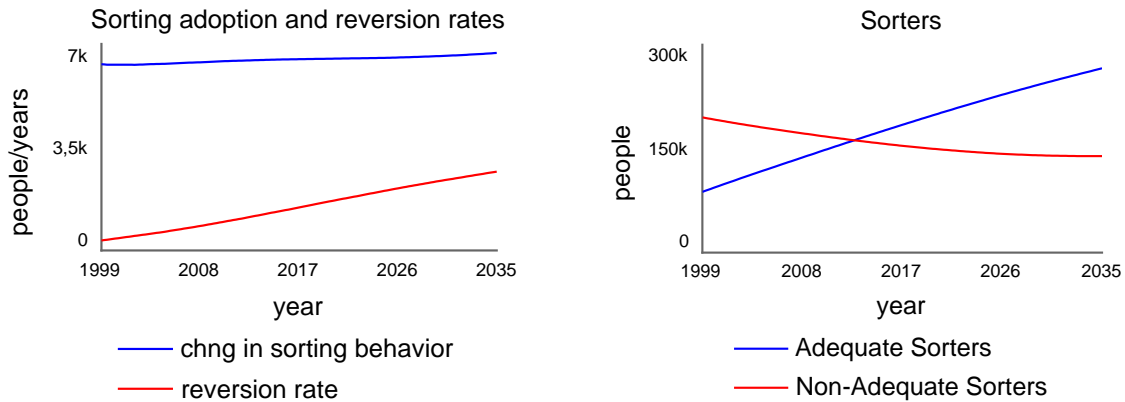

Figure 21: base run: change in households' sorting behavior and number of sorters.

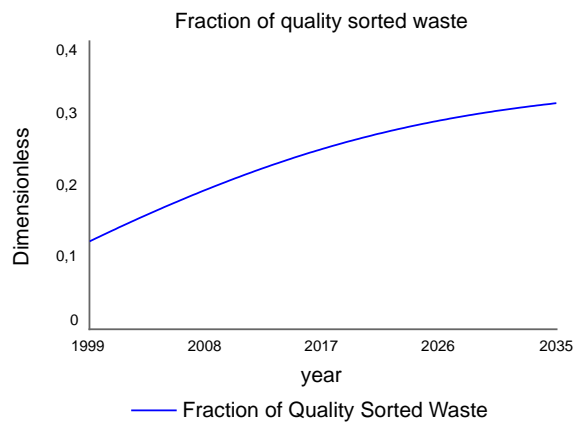

Figure 22: base run: fraction of quality sorted waste

Volume-based garbage fee system was introduced in 1998. The main purpose of the system was to motivate households to separate their waste followed by reduction in fee size.

Initially, approximately 12 % of the total waste gets recycled, the rest is burned or sent to landfill. Sorting complexity defines sorting costs which can either be monetary or time costs. Complexity of the product packaging diminishes its chances to end up in a recycling bin. Availability of drop-off recycling stations makes it less costly for the citizens to get rid of recyclables. Insufficient infrastructure not only increases sorting costs but also causes disappointment with recycling activity because of the effect of crowding.

Both packaging design and infrastructure for recycling are assumed to be sufficient.

Once the households get familiar with the concept of garbage fee and realize the benefits of recycling more people start adopting the new habit.

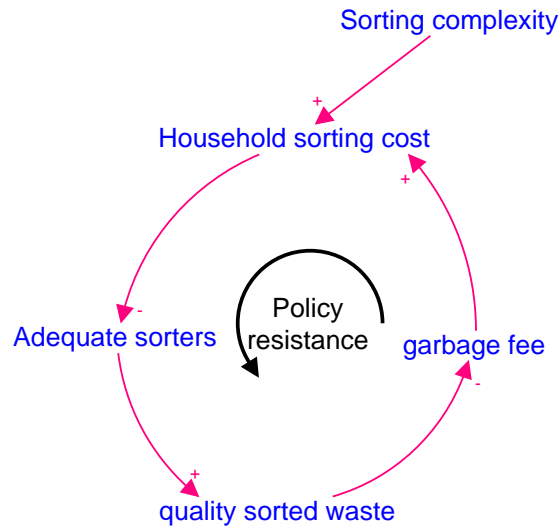

Figure 23: Policy resistance loop

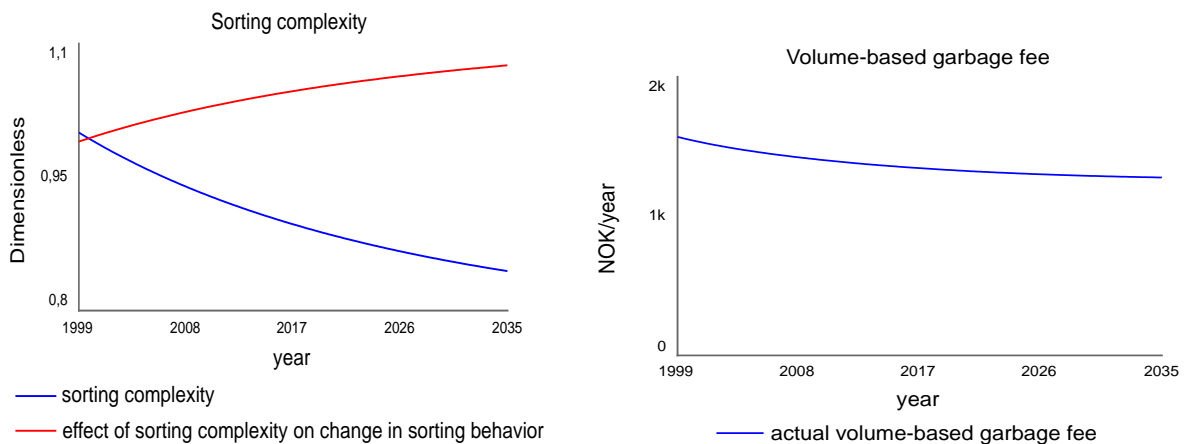

Figure 24: base run- change in household's recycling behavior

As more people separate their waste appropriately fraction of quality sorted waste increases causing garbage fee to decrease. However, as more people make use of the recycling stations the raising costs associated with the delivery of recyclables may cause poor sorting, cheating or misuse of the containers. Thus, some of the sorters lose the motivation to sort and fall back into the stock of Non-Adequate Sorters, forming a reinforcing policy resistance loop.

Some of the recyclable materials being recycled many times lose their quality over time and end up at incinerator plant. This amount increases together with the fraction of quality sorted materials which are assumed to contain secondary materials to some extent.

As it can be seen from Figure 25 in the beginning of the simulation more waste was burned rather than recycled. As sorting behavior of the citizens was improving more waste went to recycling and less waste was burned.

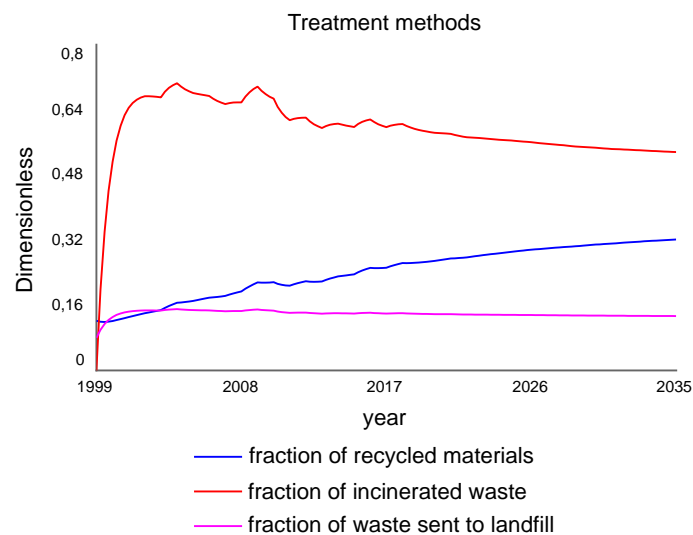

Figure 25: base run: fraction of waste treated based on treatment method

## 5.2 Scenario Analysis

This section of the thesis presents the results of the simulation model.

In order to assess possible policy outcomes two potentially interesting scenarios are analyzed in this section. These scenarios were designed by applying various parameters' values representing relationships between garbage fee and the amount of residual waste. In scenario 1, households are assumed to be more sensitive to changes in garbage fee due to better control over the garbage volume and the fee amount. In scenario 2, households are assumed to be less sensitive or even insensitive to changes in garbage fee or the amount of residual waste they generate because they

have to dispose their waste into a common container and garbage bill is usually split between neighbors.

The scenarios will be discussed at the same time and compared to the base run as well as to each other.

Scenario description: Private Houses and Apartment complexes

Population is assumed to grow from its initial value by 12 % by 2035

Waste per person remains at the level 420 kg

Since both population and waste generated per person are assumed to be the same as in the base run, there will be no difference in total waste generated, only in households' behavior.

*Private Houses scenario*: Elasticity of volume-based garbage fee to the amount of residual waste = -0,5.

*Apartment complexes scenario*: Elasticity of volume-based garbage fee to the amount of residual waste = -0,02.

The majority of the citizens in the *Private Houses scenario* live in private houses and pay volume-based garbage fee. It is assumed that a wheelie bin system is in operation and households must present their waste in a wheelie bin or it will not be collected. These households are more sensitive to changes in the amount of delivered waste and garbage fee. Once they have control over their trash bill, they are more likely to keep up waste separation.

Most of the citizens in the *Apartment complexes scenario* live in apartment complexes and share garbage containers. Garbage fee is usually split between apartment owners. This fact often leads to lack of control over their garbage bill since it is a joint responsibility. Although the garbage fee can vary, the difference might be insignificant. That makes the households insensitive to changes in garbage fee, and they will less likely change sorting habits.

Figure 26 shows that garbage fee development for the three scenarios is different. Garbage fee in the *Apartment complexes scenario* is 6 percent higher but less variable than in the base run. In the *Private Houses scenario* price, sensitive citizens pay 14 percent less compared to the base run.



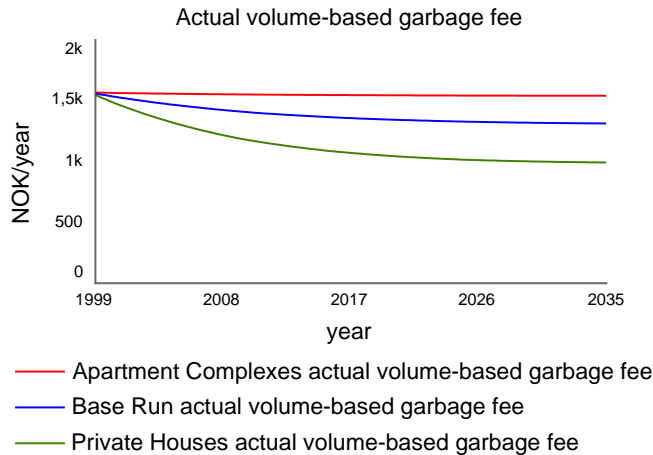

Figure 26: actual volume-based garbage fee

As people in the *Private Houses scenario* are more sensitive to changes in garbage fee, they will be more prone to improve sorting behavior compared to households in the other two scenarios.

This results in:

- 4 percent more Adequate sorters in the Private Houses scenario than in base run and
- 3 percent less Adequate sorters in the Apartment complexes scenario compared to base run.

This difference comes from sorting costs associated with crowding effect. Figure 27 represents both sorting costs and number of people who properly sort their waste.

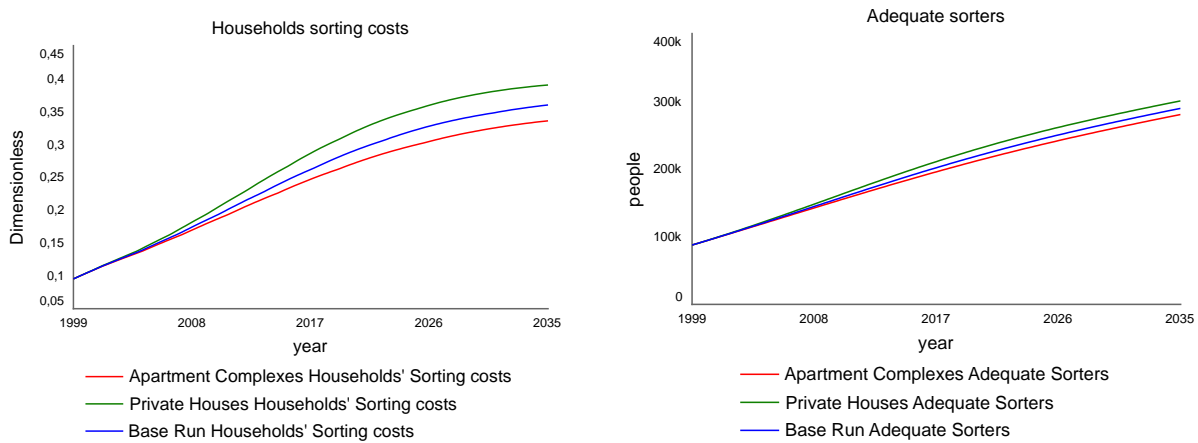

Figure 27: Households sorting costs and Adequate sorters

Sorting costs for households:

- increased by 8,3 percent, in the *Private Houses scenario* compared to the base run. On the one hand, the crowding effect makes sorting more time costly; on the other hand, peer pressure and economic incentives cause more people to separate
- decreased by 8 percent in the *Apartment complexes scenario* compared to base run.

These results would be different if sorting complexity had improved pushing the crowding effect down. However, the percentage increase in sorting cost and the percentage increase in adequate sorters is not proportional due to the feedback processes discussed above.

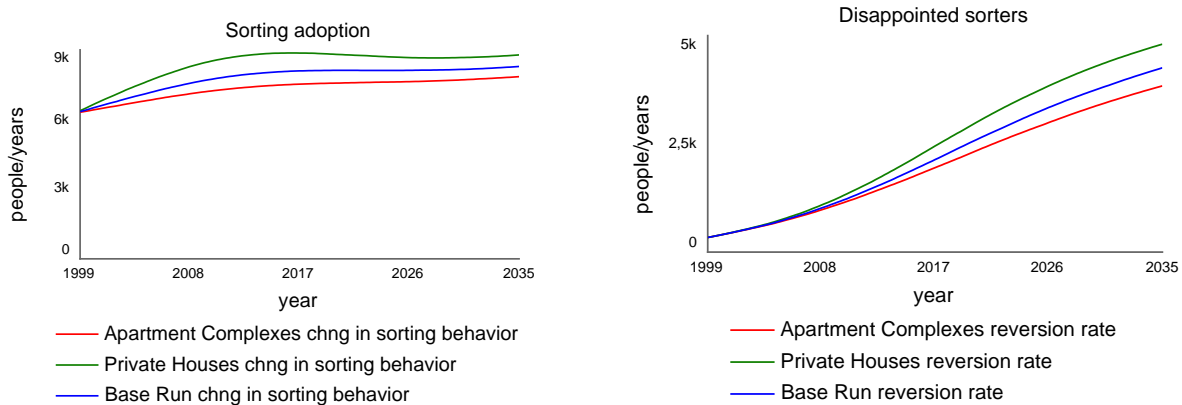

Figure 28: motivated and disappointed citizens

Table 7 shows disappointment and adoption rates compared to the results from the base run. It can be seen that price-insensitive sorters will less likely get motivated in improving their recycling behavior. Also, there will be fewer people disappointed with the sorting complexity. As for more sensitive to the garbage fee changes citizens, 6 percent more people will adopt sorting habits and also 12 percent more will quit.

Motivated sorters by 2035		Disappointed sorters By 2035
-5,3%	Apartment Complex scenario	-9%
<b>100 %</b>	<b>Base run</b>	<b>100 %</b>
+ 6 %	Private Houses scenario	+ 12,6 %

Table 7: motivated and disappointed sorters, % difference

Despite the differences in households' attitude towards recycling the fraction of quality sorted waste will not differ significantly - compared to the base run: + 3,4 percent in the *Private Houses scenario* and – 3,4 percent in the *Apartment complexes scenario* (see figure 29).

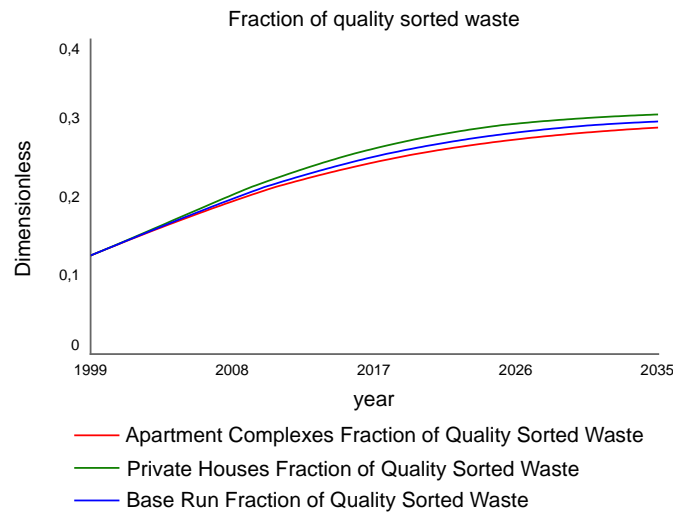

Figure 29: Fraction of quality sorted waste

In addition to the two scenarios exploring different types of households, a scenario where better recycling performance contributed to an increase in waste generated per person was also considered. Running the scenario did not show any differences in model behavior or results except from an increase in total generated waste. This result or more precisely, its' absence might point at missing relationships in the model that can be investigated in further studies. For instance, a balancing mechanism between households' perception of their own recycling performance and an extra amount of waste per person generated, compensation they want for being duty-oriented.

Depending on the households' sensitivity to different garbage fee systems the reinforcing loop (social norms) is more dominant in the *Private houses scenario* than in the base run, so that sorters grow even faster because of the impact of peer pressure. Also, the impact of crowding becomes more constraining than in the *Apartment Complex scenario*, where households are less responsive. The balancing loop becomes more dominant in the *Private Houses scenario* and slows down the

growth behavior in the stock of Adequate sorters because of both more powerful crowding effect and higher sorting complexity.

## 6. Policy Analysis

In this section, the results arising from five policy scenarios will be presented. These scenarios are as following: implementation of a new garbage fee system, provision with sufficient sorting infrastructure, packaging design improvement, and information campaigns targeting peoples' awareness and their combination. The purpose of the scenarios was to find which policy might have the greater impact on adoption of sorting behavior and, as an ultimate result on the amount of quality sorted materials for recycling.

Policy option: *weight-based garbage fee*

A new garbage fee system was implemented in 2016. The new fee system is weight-based and is assumed to be more efficient in terms of reducing residual waste. The reason is that the system provides households with the incentive to reduce the weight of their garbage and not waste volumes as compared to the volume-based system. It is also argued that a weight-based fee system is fairer when it comes to a household's size. However, it is recommended to consider whether the new garbage fee system will be more effective in a particular setting before it is implemented.

Figure 30 demonstrates how the new garbage fee system affects households' sorting behavior. It can be seen that as the new system kicks in, there will be more motivated households. The households have better control over the amount of waste they get rid of and how much money they can save if they deliver less to the waste management company by taking out more recyclables. Given the unchanged capacity of recycling stations and unchanged packaging design number of people motivated to recycle will be somewhat 2,7 percent higher than in the base run, whereas the fraction of sorted waste will grow by 3,4 percent. With this policy, the recycling rate cannot go up to the maximum value. It is not possible because of the difference between the two garbage fee systems is symbolic, providing the incentive. Nevertheless, for some people, time is more valuable

than money. Thus, the implementation of a new garbage fee policy alone might not be cost-efficient.

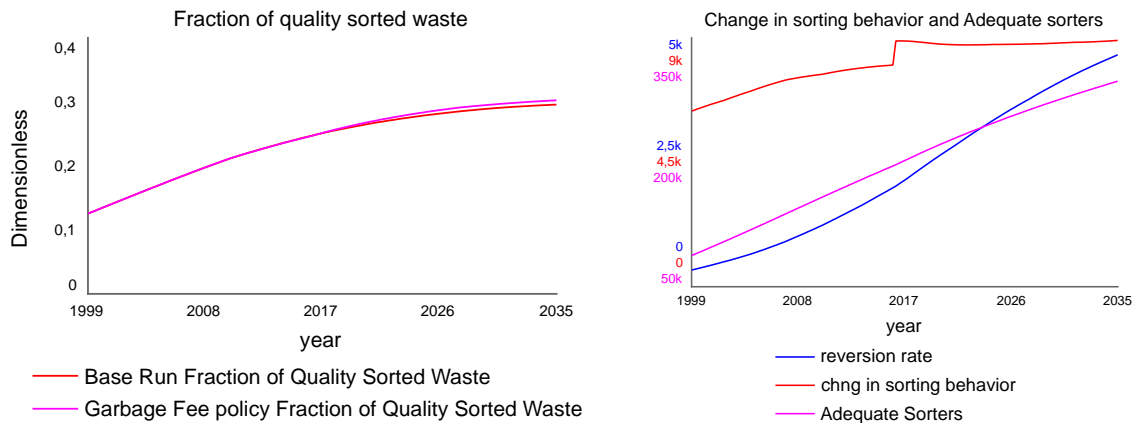

Figure 30: Garbage fee Policy. Adequate sorters and fraction of quality sorted waste

*Flat rate garbage fee scenario:*

BIR changes the fee system from differentiated to a flat rate (making the economic incentive loop inactive). This change will negatively affect the adoption rate and result in more waste for incineration. Since citizens pay less for waste collection service BIR will have to adjust the cost for collecting, transportation and treatment of waste which will result in deterioration of recycling infrastructure. On the one hand, households’ costs associated with the waste collection get cut. On the other hand, their costs associated with time spent on sorting at home and delivering to some remote recycling stations increase. Thus, enlarging the number of people becoming unwilling to recycle.

The following parameters are changed starting in 2019:

*Elasticity of volume-based garbage fee to the amount of residual waste = 0 (base run -0,2)*

*Infrastructure factor target = 0 (base run 1)*

*Elasticity of infrastructure to sorting complexity = -2,23 (base run -0,5)*

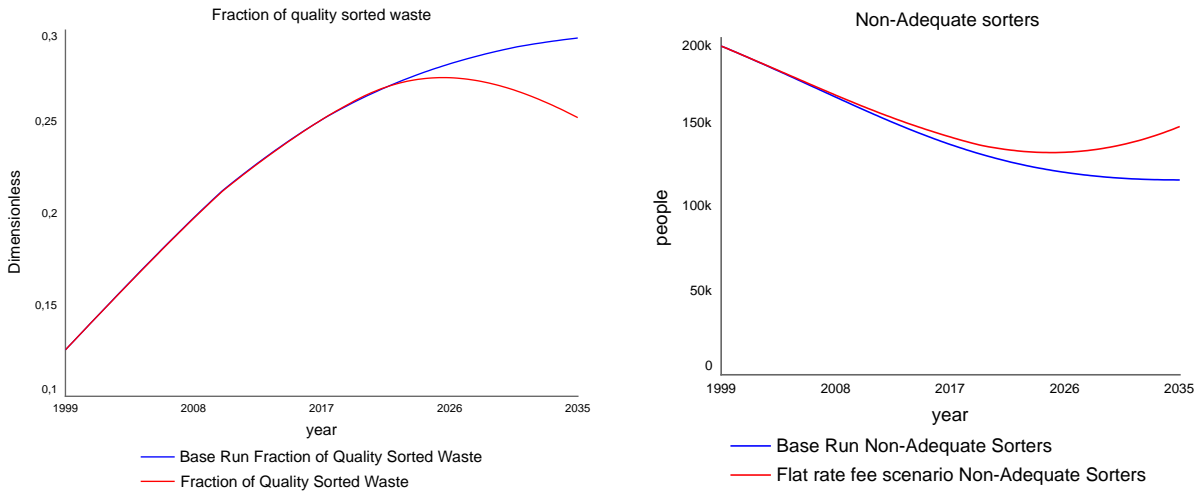

Figure 31: flat rate garbage fee scenario: Non-Adequate sorters and fraction of quality sorted waste

Policy option: *Sorting infrastructure*

Infrastructure availability provides an incentive to become an adequate sorter. Increased capacity of sorting infrastructure allows to reduce sorting cost meaning that more recycling stations and various sorting bins are available. Since costs associated with collecting and waste treatment are out of the model boundary it limits model's ability to find the optimal infrastructure provision. This can be done by adding the cost of waste treatment and profits waste management company gets. Also, in addition to sorting infrastructure and packaging design sorting complexity implies number of recycling streams, which could also be added to the model and used for policy testing.

Initial infrastructure policy = 0,4 (base run = 0,8)

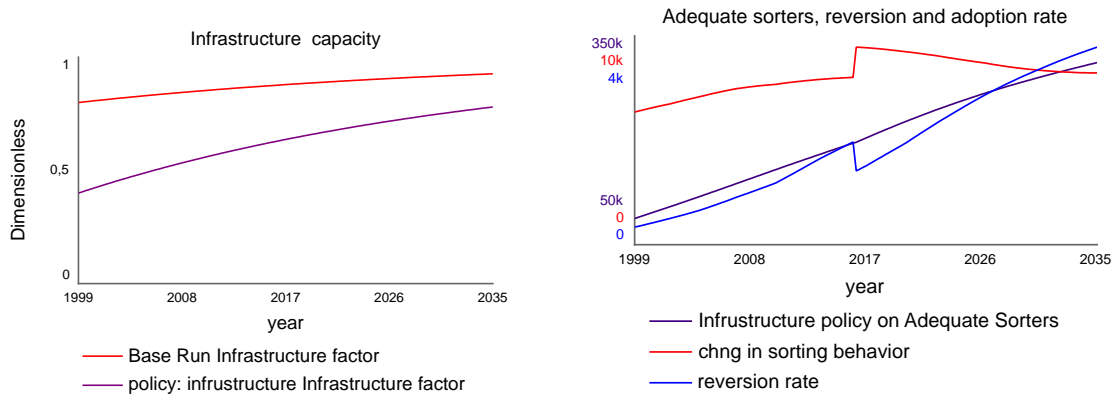

Figure 32: policy: increased infrastructure capacity

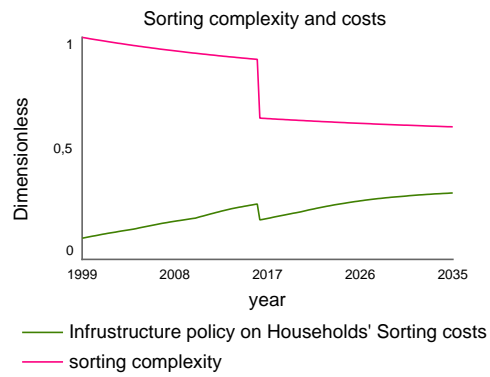

Figure 33: Infrastructure policy ON. Sorting cost and complexity

Figure 33 shows sorting costs for infrastructure policy and the two scenarios

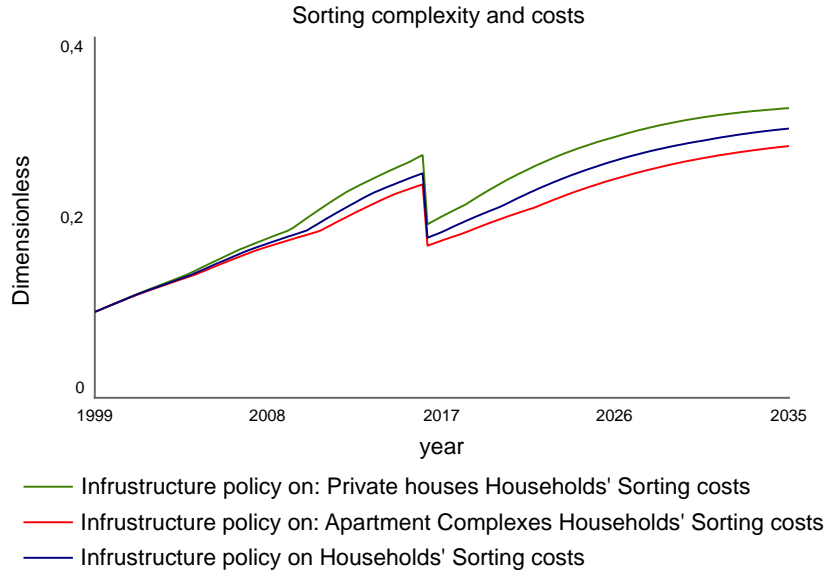

Figure 34: Infrastructure policy. Sorting costs

As can be seen from the graph that because of the stronger crowding effect households living in private houses are more sensitive to availability of sorting infrastructure than both those who live in apartment. The behavior shows that this policy can, in principle, be considered to improve recycling fraction. However, in order to find the magnitude of policy effectiveness, more research on people’s decision-making process, such as the effect of crowding on sorting costs and the effect of sorting costs on disappointment is needed.

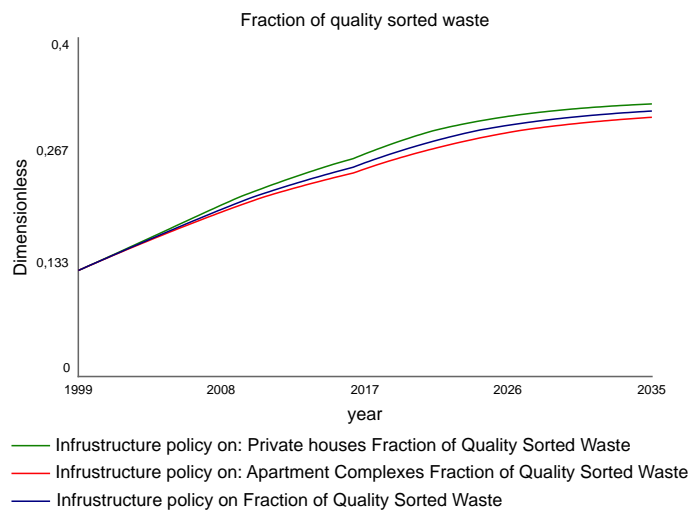

Figure 35: Infrastructure policy. Fraction of quality sorted waste



Policy option: *Packaging design*

Both more straightforward packaging design and information on how to recycle hybrid packaging, such as milk carton with a plastic lead make the separation process less confusing. Confusion with separating composite materials causes more recyclables to end up at incinerator plant either due to contaminated recycling streams or less amount of sorted waste.

- Initial packaging design = 0,2 (base run = 0,6)

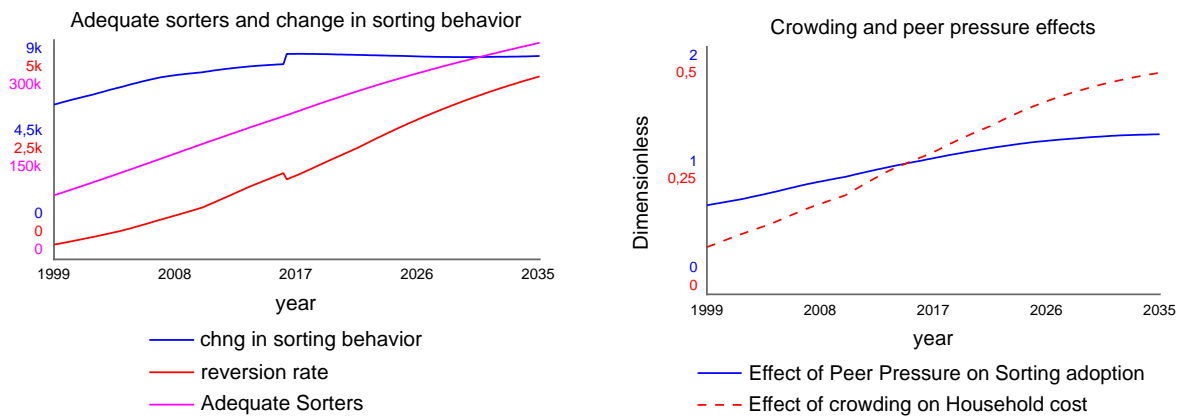

Figure 36: *Packaging design policy. Sorting behavior*

More suitable packaging design allows to reduce time spent on waste sorting at home and thus, number of adequate sorters grows. Also, the amount of materials going to material recovery increases.

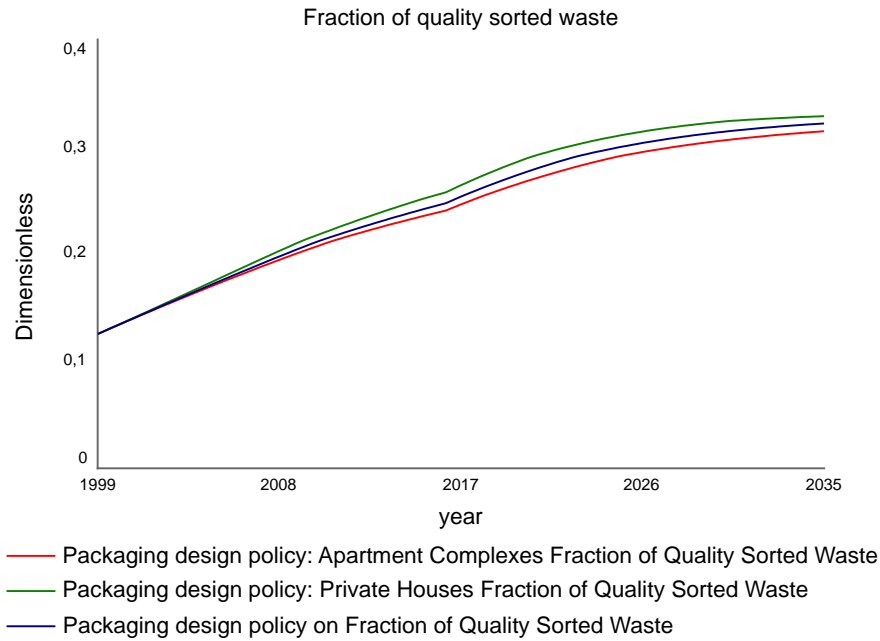
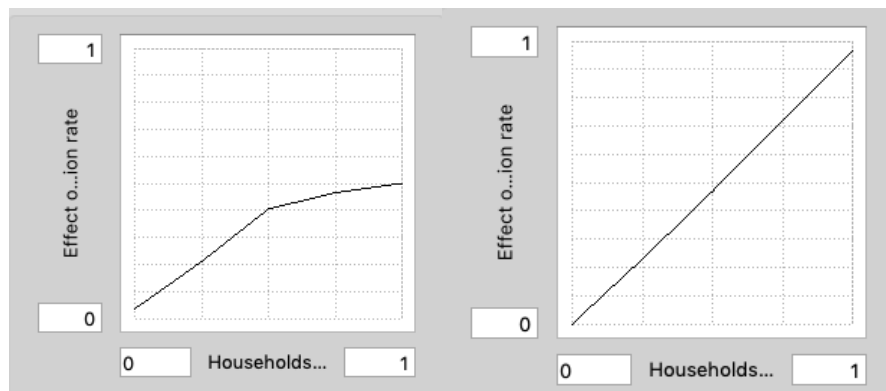
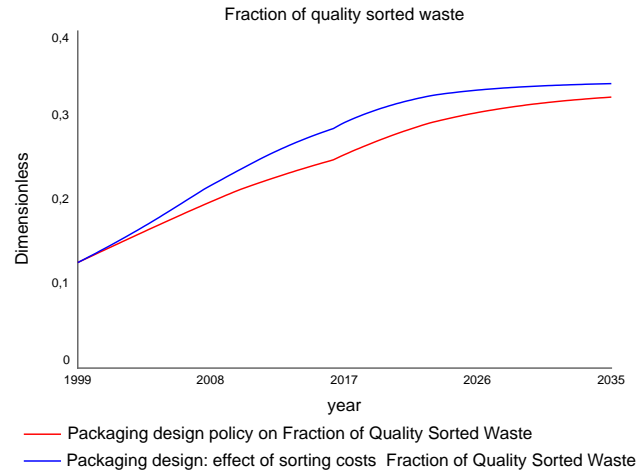

Figure 37: Fraction of quality sorted waste. Packaging design policy.

Since there is limited data about the effects representing human behavior in the model, a couple of sensitivity runs are performed in order to test the sensitivity of both policies. It is assumed that information campaigns can vary the shapes of these effects, implying that increasing knowledge about recycling and awareness influence the sorting behavior of the citizens.

- Sensitivity of *packaging policy*: effect of households' sorting costs on reversion rate is less powerful (left-hand side graph) than in the base run (right-hand side graph).

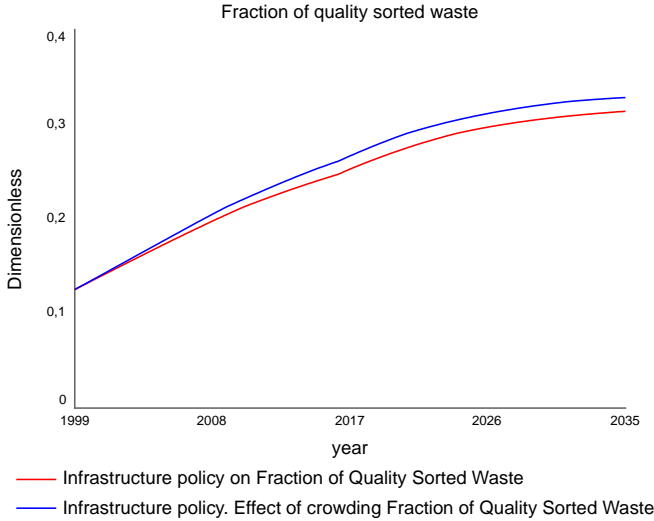



*Figure 38: Fraction of quality sorted waste. Packaging policy ON, change in the effect HH sorting costs on reversion rate*

Both more straightforward packaging design and information on how to recycle hybrid packaging, such as milk carton with a plastic lead decrease confusion. Confusion with separating composite materials causes more recyclables to end up at incinerator plant either due to contaminated recycling streams or less amount of sorted waste. Figure 36 shows that fraction of quality sorted waste increases with better packaging design. Both sorting complexity and increased knowledge about recycling reduce sorting households' sorting costs as well as disappointment with recycling.

Sensitivity of *infrastructure policy*: *effect of crowding* is less powerful than in the base *Infrastructure policy* run



*Figure 39: sensitivity of Infrastructure policy to change in effect of crowding on households' sorting cost*

This means that after launching an information campaign which provides the information about a home collection of hazardous wastes, households are more willing to spend time on separating and delivering hazardous waste to a waste management company so that it is handled safely and professionally. The anticipated result is more waste handled properly because of increased awareness of the citizens. As a matter of fact, such campaigns are costly for waste management company, however BIR collects and handles hazardous wastes from the citizens free of charge.

- effect of peer pressure is more powerful than in the base infrastructure policy run

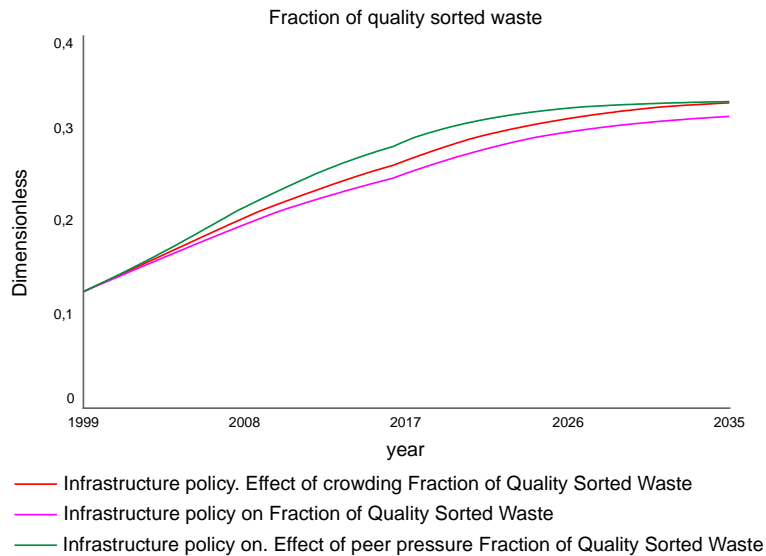
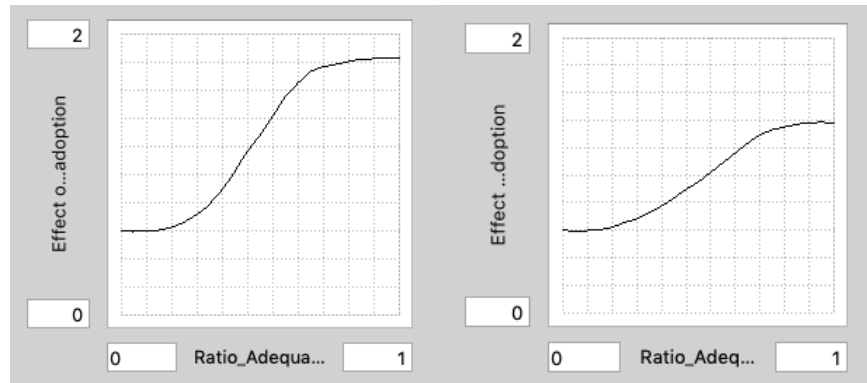

Figure 40: fraction of quality sorted waste. Infrastructure policy

A newspaper article in a local newspaper highlighting recycling performance of inhabitants living in different parts of the country might result in increased awareness of social norms. Since by nature people want to be perceived as duty-oriented and are willing to contribute only if others are doing so too, peer pressure effect will motivate more people to do what others do paying less attention to sorting costs. Fraction of quality sorted waste can increase up to 4 percent more compared to the case with the less powerful peer pressure effect.

The effects representing people's decision making are considered to be quite sensitive. In order to design and analyze a real policy it is advised to collect more robust data on these effects.

Households' sorting behavior in the different policy scenarios changes differently. This is so because the balancing sorting cost loop and the reinforcing peer pressure loop are more powerful in the packaging design scenario than in both the infrastructure and the garbage fee scenarios.

Combination of policy scenarios:

Here, the results from various combinations of policy scenarios are presented.

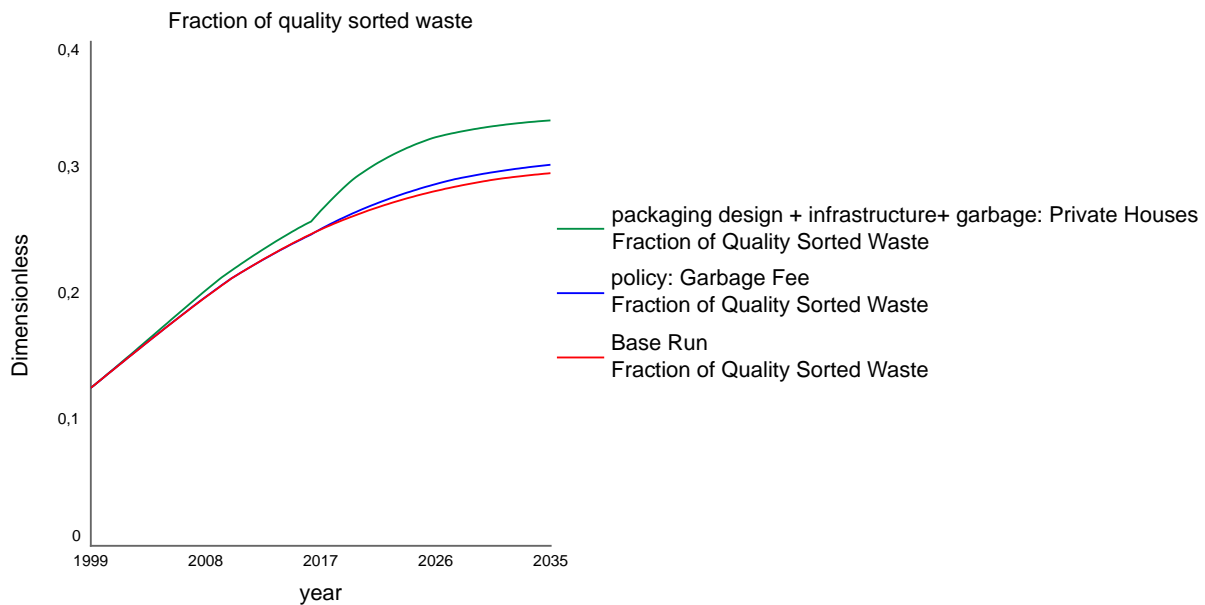

Figure 41: Policy outcomes compared to the base run

Figure 40 shows the best policy outcome (fraction of quality sorted waste increased with 14 percent relative to the base run) resulting from the combination of improved packaging design, available infrastructure and weight-based garbage fee in a *Private Houses Scenario*. The least effective

policy (fraction of quality sorted waste increased with 2 percent relative to the base run) is a *weight-based garbage fee* policy alone. More results on other policy combinations are provided in table 6.

Scenario	Fraction of quality sorted waste
Base run	0,296
Packaging design + infrastructure + garbage fee: Private Houses scenario	0,338
Packaging design + infrastructure + garbage fee	0,335
Packaging design + infrastructure + garbage fee: Apartment Complexes scenario	0,332
Packaging design + infrastructure	0,330
Packaging design + garbage fee	0,327
infrastructure + garbage fee: Private Houses scenario	0,324
Packaging design	0,322
Infrastructure + garbage fee: Apartment Complexes	0,317
Infrastructure	0,314
Garbage fee	0,302
Flat rate garbage fee	0,256

*Table 8: fraction of quality sorted waste: policy combinations*

The degree of change in recycling rate depends on modifications of the scenario parameters. The balancing feedback loop representing households' sorting costs and the reinforcing peer pressure loop alter the adoption of sorting behavior more in some than in other scenarios leading to different values of the fraction of recycling rate (fraction of quality sorted waste).

Summing up, none of the proposed policy scenarios has shown significant increase in recycling fraction (up to a goal of 65 percent).

## 7. Conclusion

According to Norway's national target in the environment area, the recycling rate of municipal waste has to increase up to 65 % by 2035.

As demonstrated in this study we have explored why the rate of material recycling in the Bergen area is currently below the target. In addition, the research questions have been answered to find out what it takes to improve the recycling performance.

Based on the findings in this study we can conclude that recycling levels greatly depend on the household's participation. Even the most carefully designed recycling program will not succeed without the participation of the citizens. The following policy instruments are found to have a positive effect on recycling behavior of the citizens: economic incentive in the form of differentiated garbage fee; a well-developed sorting infrastructure; convenient product packaging that reduces sorting time and effort; information campaigns that aim to increase citizens' environmental awareness and motivation to recycle.

The results of the model analysis demonstrate that differentiated garbage fee appear to be an essential factor in any waste management system because unlike a flat rate fee, it provides citizens with the incentives to separate their waste.

From the results, it is clear that before any policy is implemented a careful assessment of the possible outcomes and cost-effectiveness analysis should be performed. This is especially valid for the garbage fee policy since unexpected side effects, such as misuse of recycling stations and uncontrolled waste disposal might take place. The best policy outcome (34 % recycling rate by 2035) results from the combination of improved packaging design, available infrastructure and weight-based garbage fee system in a Private Houses Scenario. The findings confirm that the achievement of the ambitious target of 65 % might become a challenge for both citizens and the government.



Since the model is designed for strategic decision making, a specific model structure is needed to provide with the insights on operational decision making. However, with some adjustments, the model could be applied in countries with less advanced waste management systems such as Russia, since it allows to see the big picture.

In Russia, a flat rate garbage fee system is mostly in use, and as a result, most of the waste goes to landfill. The model can be used to consider transition to the more environmentally friendly waste treatment methods and hence, contribute to further development of the Circular Economy.

Both environmental impacts from various waste treatment methods and cost-effectiveness can be measured, although that would require additional model structure.

The adoption structure in the sorting sector seems to be applicable in studying citizens' reaction to road pricing.

While working on the thesis, new research questions which could have been followed up but were beyond the framework of this project have emerged. It would be interesting to investigate whether setting a clear goal for recycling rate would improve citizens' recycling performance. It would also be interesting to find out what kind of waste prevention measures could be applied to reduce waste generation per person and whether there is a relationship between households' recycling performance and an increase in waste generated per person.

Under the current conditions represented in the model we can conclude it is unlikely that Bergen will reach the government's goal of 65% recycling rate. The current policies and incentive structure, although they have a positive effect, is not enough to reach the desired goal. This is due to lack of a developed market for recycled materials. A developed market for recycled materials would give incentives for producers to design the packaging in a way that would make recycling easier and more attractive, comparable with deposit return on bottles. Another factor that could improve the recycling rate is improved communication directly with the citizenry where the recycling goal is clearly stated and compared with current level in order to orientate the public towards this goal. However, this is a subject for another study.

## List of Appendices

### Appendix I: Model documentation

Here the simulation model is reported. Model reporting allows to recreate the model and simulate it in the base-case (Rahmandad & Sterman, 2012).

The model has 88 variables:

Stocks: 10

Flows: 14

Converters: 64

Constants: 25

Equations: 53

Graphicals: 10

There are also 15 expanded macro variables.

The base-case simulation specifications:

Integration Method: Euler

Time Unit: years

Time Step: 0,25

Time Horizon: 36 years (1999-2035)

**Average fraction of metals in ash = 0, 014**

UNITS: 1/year

DOCUMENT: The average annual fraction of metals in ashes is 1,4 % of the total generated household waste (BIR statistics).

Incinerator bottom ash is a form of ash produced in incineration facilities. The bottom ash typically has a small amount of ferrous metals contained within it.

Metals are sorted out from ashes and sold out on the London exchange at high prices since scrap has monetary value.

**Average fraction to landfill** = 0,1

UNITS: Dimensionless/year

DOCUMENT: residues from burning waste should be landfilled and constitutes 10 % of incinerated waste each year.

**"effect of fraction of sorted waste on fraction of end-of-life materials"** =

(Fraction of Quality Sorted Waste/initial fraction of quality sorted waste) ^"elasticity of sorted waste to end-of-life materials"

UNITS: Dimensionless

DOCUMENT: It is assumed that recycled packaging materials are back into the loop eventually.

Some recyclable materials can be recycled over and over again, but others can only be recycled so many times before they are downcycled.

**"elasticity of sorted waste to end-of-life materials"**= 0,5

UNITS: Dimensionless

DOCUMENT: the elasticity is meant to increase the amount of sorted materials that goes to incineration instead of recycling.

**Fraction energy produced per year** = 1

UNITS: 1/year

DOCUMENT: amount of waste that was burned is used for energy production.

**"fraction of end-of-life materials"** =

"normal fraction of end-of-life materials"\*"effect of fraction of sorted waste on fraction of end-of-life materials"

UNITS: Dimensionless/year

DOCUMENT: Post-consumer packages can either be treated as waste or can be recycled, these are the so-called end-of-life options. Fraction that goes to incinerator plant is a product of a normal (average) fraction and the effect based on the number of recyclables sorted.

**Fraction of incinerated waste** = Energy production rate/ (Waste to Landfill + Waste to Incineration Waste to Recycling)

UNITS: Dimensionless

DOCUMENT: a fraction of waste that was burned relative to the total amount of treated waste.

**Fraction of recycled materials** = materials sent to recycling facilities/ (Waste to Landfill + Waste to Incineration + Waste to Recycling)

UNITS: Dimensionless

DOCUMENT: a fraction of materials recycled relative to the total amount of treated waste.

**Fraction of waste for landfilling** = 0,08

UNITS: Dimensionless

DOCUMENT: The only things we landfill now is ashes from incinerator plant, tiles tires and concrete (Interview with BIR).

**Fraction of waste sent to landfill** = total landfill/(Waste to Landfill + Waste to Incineration + Waste to Recycling)

UNITS: Dimensionless

DOCUMENT: a fraction of waste that was landfilled relative to the total amount of treated waste.

**Fraction sent to recycling facilities** = 1

UNITS: 1/year

DOCUMENT: amount of waste that was sent to recycling facilities.

**Landfill(t)** = Landfill (t - dt) + (ash to landfill + Waste to Landfill) \* dt {NON-NEGATIVE}

INIT Landfill = 0

UNITS: ton

INFLOWS:

Ash to landfill = "Waste-to-Energy Facility"\*average fraction to landfill {UNIFLOW}

UNITS: ton/year

Waste to Landfill = Total generated waste\*fraction of waste for landfilling {UNIFLOW}

UNITS: ton/year

DOCUMENT: the stock accumulates residuals coming from incinerator plant and wastes from the citizens. There is no outflow from the stock because waste due to its' composition materials remains on the landfill for a very long period of time.

**Materials to recycle**(t) = Materials to recycle (t - dt) + (Metals for recycling + Waste to Recycling – materials sent to recycling facilities – recyclables to incineration) \* dt {NON-NEGATIVE}

INIT Materials to recycle = 14762

UNITS: ton

DOCUMENT: Tones of materials that have been sent to recycling are accumulated in the stock.

INFLOWS:

Metals for recycling = "Waste-to-Energy Facility"\*average fraction of metals in ash {UNIFLOW}

UNITS: ton/year

DOCUMENT: metals that remain in ash after burning waste are sent to recycling.

Waste to Recycling = Total generated waste\*Fraction of Quality Sorted Waste {UNIFLOW}

UNITS: ton/year

DOCUMENT: wastes separated by the households.

OUTFLOWS:

Materials sent to recycling facilities = Materials to recycle\*fraction sent to recycling facilities {UNIFLOW}

UNITS: ton/year

DOCUMENT: tones of materials sent to recycling facilities.

Recyclables to incineration = Materials to recycle\*"fraction of end-of-life materials"  
{UNIFLOW}

UNITS: ton/year

DOCUMENT: materials that should not go to recycling because they might contain hazardous elements (interview with BIR).

**"normal fraction of end-of-life materials" = 0,04**

UNITS: Dimensionless/year

**Total 100 %** = fraction of recycled materials + fraction of incinerated waste + fraction of waste sent to landfill

UNITS: Dimensionless

DOCUMENT: a sum of all the fractions based on treatment method. Since there is no illegal waste disposal in the municipalities the fraction is equal to 100 %.

**Total generated waste** = Population\*reference waste per person

UNITS: ton/year

DOCUMENT: total amount of waste generated in the area depends on the number of citizens and the amount of waste per person.

**Total landfill** = ash to landfill + Waste to Landfill

UNITS: ton/year

DOCUMENT: total amount of waste disposed of to landfill.

**Total recycled** = fraction of recycled materials + fraction of incinerated waste

UNITS: Dimensionless

DOCUMENT: A sum of both materials and energy recovered as a percentage of the total generated waste.

**"Waste-to-Energy Facility"**(t) = "Waste-to-Energy Facility"(t - dt) + (recyclables to incineration + Waste to Incineration – Energy production rate – Metals for recycling – ash to landfill) \* dt  
{NON-NEGATIVE}

INIT "Waste-to-Energy Facility" = 0

UNITS: ton

DOCUMENT: The plant was opened in 1999 for energy generation. The stock accumulates residual waste from citizens.

INFLOWS:

**Recyclables to incineration** = Materials to recycle\*"fraction of end-of-life materials"  
{UNIFLOW}

UNITS: ton/year

DOCUMENT: materials that might contain hazardous elements but considered as recyclables sent to incinerator plant.

**Waste to Incineration** = Total generated waste-Waste to Landfill-Waste to Recycling  
{UNIFLOW}

UNITS: ton/year

DOCUMENT: waste that is neither sent to landfill nor recycling facility is sent to incinerator plant.

OUTFLOWS:

**Energy production rate** = "Waste-to-Energy Facility"\*fraction energy produced per year  
{UNIFLOW}

UNITS: ton/year

DOCUMENT: waste combustion reduces its' amount at incinerator plant due to generation of energy.

**Metals for recycling** = "Waste-to-Energy Facility"\*average fraction of metals in ash  
{UNIFLOW}

UNITS: ton/year

DOCUMENT: transportation of metals contained within ash to the stock that contains materials for recycling.

**Ash to landfill** = "Waste-to-Energy Facility"\*average fraction to landfill {UNIFLOW}

UNITS: ton/year

\*\*\*\*\*

Sorting sector:

\*\*\*\*\*

**"actual volume-based garbage fee"** = "initial volume-based garbage fee"\*"Effect of Sorted Waste on volume-based garbage fee"

UNITS: NOK/year

DOCUMENT: An important goal of implementing a variable-rate system is to create an economic incentive for recycling and waste avoidance (Thøgersen, 1994).

Volume-based fee changes based on the amount of waste presented to the waste management company.

**"actual weight-based garbage fee"** =

IF TIME > 2016

THEN "Initial weight-based garbage fee"\*"Effect of sorted waste on weight-based garbage fee"

ELSE "Initial weight-based garbage fee"

UNITS: NOK/year

DOCUMENT: is a policy variable that kicks in 2016 meaning that volume-based garbage fee system is replaced by a weight-based garbage fee system.

**Adequate Sorters**(t) = Adequate Sorters (t - dt) + (chng in sorting behavior – reversion rate) \* dt  
{NON-NEGATIVE}

INIT Adequate Sorters = Population-"Non-Adequate Sorters"

UNITS: people

DOCUMENT: Most of the BIR's customers can be characterized as duty-oriented (adequate). The initial value of the stock is an assumption which is based on the expert opinion working for BIR.



**INFLOWS:**

chnge in sorting behavior = "Non-Adequate Sorters"\* Sorting Adoption Fraction/time to change behavior {UNIFLOW}

UNITS: people/years

**OUTFLOWS:**

Reversion rate = (Adequate Sorters\*fraction of sorters disappointed with sorting cost)/time to change behavior {UNIFLOW}

UNITS: people/years

DOCUMENT: it is assumed that households might get disappointed with the sorting costs.

**Effect of crowding on Household cost = GRAPH (Ratio Adequate Sorters to Total Sorters)**

(0,000, 0,053), (0,050, 0,0515), (0,100, 0,053), (0,150, 0,043), (0,200, 0,050), (0,250, 0,070), (0,300, 0,090), (0,350, 0,12), (0,400, 0,14), (0,450, 0,17), (0,500, 0,21), (0,550, 0,25), (0,600, 0,29), (0,650, 0,347), (0,700, 0,41), (0,750, 0,47), (0,800, 0,54), (0,850, 0,63), (0,900, 0,73), (0,950, 0,835), (1,000, 0,950)

UNITS: Dimensionless

DOCUMENT: crowding effect takes place when more people use drop-off recycling stations.

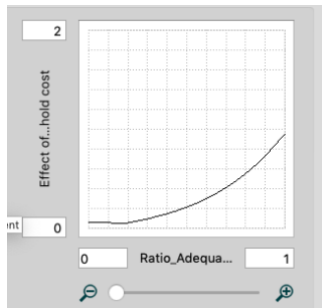

*Figure 42: effect of crowding on households' cost*

**Effect of relative garbage fee on change in sorting behavior = GRAPH (Relative Garbage Fee)**

(0,000, 1,840), (0,200, 1,670), (0,400, 1,470), (0,600, 1,320), (0,800, 1,160), (1,000, 1,000), (1,200, 0,830), (1,400, 0,660), (1,600, 0,500), (1,800, 0,380), (2,000, 0,270)

UNITS: Dimensionless

DOCUMENT:

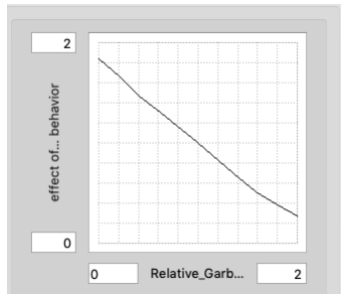

Figure 43: effect of relative garbage fee on change in sorting behavior

**Effect of HH sorting cost on change in reversion rate = GRAPH (Households' Sorting costs)**

(0,000, 0,000), (0,250, 0,229), (0,500, 0,468), (0,750, 0,718), (1,000, 0,968)

UNITS: Dimensionless

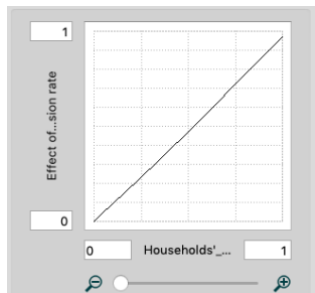

Figure 44: Effect of HH sorting cost on change in reversion rate

**Effect of infrastructure factor on sorting complexity = (Infrastructure factor/Initial infrastructure factor) ^ Elasticity of Infrastructure to sorting complexity**

UNITS: Dimensionless

DOCUMENT: this effect represents how convenience of recycling (infrastructure available) may influence recycling behavior.

**Effect of Packaging Design on sorting complexity** = (Packaging design for recycling/Initial Packaging design) ^Elasticity of packaging design to sorting complexity

UNITS: Dimensionless

DOCUMENT: packaging designed in such a way which makes it easier for households to sort their waste without thinking too much to which bin goes certain parts of product packaging.

**Effect of Peer Pressure on Sorting adoption** = GRAPH (Ratio Adequate Sorters to Total Sorters)

(0,000, 0,600), (0,045, 0,590), (0,090, 0,596), (0,136, 0,600), (0,181, 0,620), (0,220, 0,650), (0,270, 0,680), (0,310, 0,720), (0,360, 0,770), (0,400, 0,820), (0,450, 0,890), (0,500, 0,950), (0,545, 1,020), (0,590, 1,090), (0,636, 1,160), (0,680, 1,230), (0,720, 1,285), (0,770, 1,328), (0,818, 1,350), (0,863, 1,370), (0,900, 1,380), (0,954, 1,384), (1,000, 1,380)

UNITS: Dimensionless

DOCUMENT: Social interaction in recycling behavior might originate from Duty orientation and/ or the fear of social sanctions, or the desire of social approval (e.g., Coleman 1990).

In a public good context, individuals are willing to contribute only if others are doing so too (Nyborg, Howarth, and Brekke 2006).

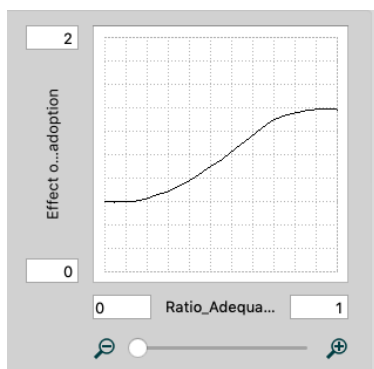

Figure 45: Effect of Peer Pressure on Sorting adoption

**Effect of ratio adequate sorters on fraction of quality sorted waste** = GRAPH (Ratio Adequate Sorters to Total Sorters)

(0,000, 0,120), (0,100, 0,315), (0,200, 0,600), (0,300, 0,990), (0,400, 1,365), (0,500, 1,740), (0,600, 2,070), (0,700, 2,385), (0,800, 2,655), (0,900, 2,865), (1,000, 2,985)

UNITS: Dimensionless

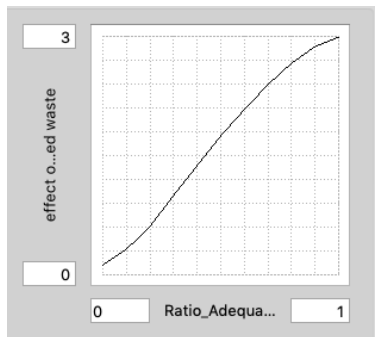

Figure 46: effect of ratio adequate sorters on fraction of quality sorted waste

**"Effect of Sorted Waste on volume-based garbage fee"** = Relative Fraction of Quality Sorted Waste ^ "Elasticity of volume-based garbage fee to the amount of residual waste"

UNITS: Dimensionless

**"Effect of sorted waste on weight-based garbage fee"** = Relative Fraction of Quality Sorted Waste ^ "Elasticity of weight-based garbage fee to the amount of residual waste"

UNITS: Dimensionless

DOCUMENT: introduction of Unit Based Price has a small but significant negative effect on unsorted waste quantities.” (A. Allers & Hoeben, 2010)

### Effect of sorting complexity on change in sorting behavior

= GRAPH (sorting complexity)

(0,000, 1,840), (0,200, 1,640), (0,400, 1,460), (0,600, 1,290), (0,800, 1,140), (1,000, 1,000), (1,200, 0,870), (1,400, 0,760), (1,600, 0,670), (1,800, 0,600), (2,000, 0,540)

UNITS: Dimensionless

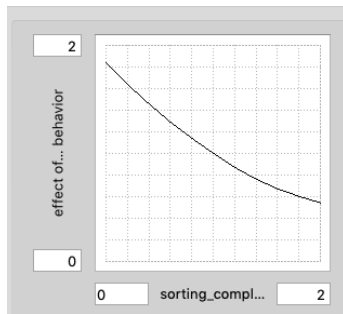

Figure 47: effect of sorting complexity on change in sorting behavior

### Elasticity of Infrastructure to sorting complexity = -0,5

UNITS: Dimensionless

DOCUMENT: available infrastructure makes it easier to sort reducing the costs for the citizens.

### Elasticity of packaging design to sorting complexity = -0,5

UNITS: Dimensionless

DOCUMENT: better (eco-design) packaging design makes it less complicated to sort waste.

### "Elasticity of volume-based garbage fee to the amount of residual waste" = -0,2

UNITS: Dimensionless

DOCUMENT: residual waste reduction caused by an increase in garbage fee (A. Allers & Hoeben, 2010)

### "Elasticity of weight-based garbage fee to the amount of residual waste" = -0,5

UNITS: Dimensionless

DOCUMENT: residual waste reduction caused by an increase in garbage fee (A. Allers & Hoeben, 2010).

**Fraction of Quality Sorted Waste =**

MIN (effect of ratio adequate sorters on fraction of quality sorted waste\*initial fraction of quality sorted waste; 0,6)

UNITS: Dimensionless

DOCUMENT: it is assumed that it is not realistic for households to sort out 100 % of their waste, that is why fraction of quality sorted materials is limited to 60 %.

**Fraction of sorters disappointed with sorting cost =** (initial fraction of sorters disappointed with sorting cost\*Effect of HH sorting cost on change in reversion rate)

UNITS: Dimensionless

**Households' Sorting costs =** sorting complexity\*Effect of crowding on Household cost

UNITS: Dimensionless

DOCUMENT: a number of undesirable effects tend to increase with the size of the incentive. Costs for the households in terms of both time and money will increase with crowding and decrease as sorting complexity (more containers and better packaging design) decreases.

**Infrastructure factor(t) =** Infrastructure factor (t - dt) + (change in infrastructure factor) \* dt  
{NON-NEGATIVE}

INIT Infrastructure factor = Initial infrastructure factor

UNITS: Dimensionless

INFLOWS:

Change in infrastructure factor = (Infrastructure factor Target-Infrastructure factor)/Time to reach infrastructure Target

UNITS: Per Year

DOCUMENT: the stock represents available infrastructure for recycling and its' potential for improvement.

**Infrastructure factor potential(t)** = infrastructure factor potential (t - dt) + ( - change in infrastructure factor) \* dt {NON-NEGATIVE}

INIT infrastructure factor potential = 1-Infrastructure factor

UNITS: Dimensionless

OUTFLOWS:

Change in infrastructure factor = (Infrastructure factor Target-Infrastructure factor)/Time to reach infrastructure Target

UNITS: Per Year

**Infrastructure factor Target** = 1

UNITS: Dimensionless

**Initial fraction of quality sorted waste** = 0,122

UNITS: Dimensionless

DOCUMENT: Statistical data provided by BIR.

**Initial fraction of sorters disappointed with sorting cost** = 0,044

UNITS: 1

**Initial infrastructure factor** = 0,8

UNITS: Dimensionless

DOCUMENT: sorting infrastructure is assumed to be sufficient. Assumption based on observations.

**Initial Packaging design** = 0,6

UNITS: Dimensionless

DOCUMENT: packaging design is assumed to be quite sufficient with a potential for improvement that might decrease sorting complexity. Assumption based on observations.

**Initial Sorting Adoption Fraction** = 0,045

UNITS: Dimensionless

**"initial volume-based garbage fee"** = 1568

UNITS: NOK/year

DOCUMENT: source: data on garbage fee development 1998-2019, BIR.

**"Initial weight-based garbage fee"** = 1932

UNITS: NOK/year

DOCUMENT: source: data on garbage fee development 1998-2019, BIR.

**"Non-Adequate Sorters"**(t) = "Non-Adequate Sorters"(t - dt) + (chng in pop Non-Adequate sorters + reversion rate – chng in sorting behavior) \* dt {NON-NEGATIVE}

INIT "Non-Adequate Sorters" = Population\*0,69

UNITS: people

DOCUMENT: people in this stock either sort badly or do not sort at all. Mostly, these are people who value the environment but need to be provided with either more information or incentives.

INFLOWS:

Chng in pop Non-Adequate sorters = net change in population

UNITS: people/years

DOCUMENT: this flow accounts for the population change over time

**Reversion rate** = (Adequate Sorters\*fraction of sorters disappointed with sorting cost)/time to change behavior {UNIFLOW}

UNITS: people/years

DOCUMENT: people giving up their good sorting behavior because of increased costs.



OUTFLOWS:

**Chng in sorting behavior** = "Non-Adequate Sorters"\*Sorting Adoption Fraction/time to change behavior {UNIFLOW}

UNITS: people/years

DOCUMENT: change in citizens' sorting behavior induced by garbage fee or peer pressure.

**Packaging design for recycling(t)** = Packaging design for recycling(t - dt) + (change in Packaging design) \* dt {NON-NEGATIVE}

INIT Packaging design for recycling = Initial Packaging design

UNITS: Dimensionless

INFLOWS:

**Change in Packaging design** = (Packaging design Target-Packaging design for recycling)/Time to reach Packaging design Target

UNITS: Per Year

**Packaging design Potential(t)** = Packaging design Potential (t - dt) + (- change in Packaging design) \* dt {NON-NEGATIVE}

INIT Packaging design Potential = 1-Packaging design for recycling

UNITS: Dimensionless

OUTFLOWS:

**Change in Packaging design** = (Packaging design Target-Packaging design for recycling)/Time to reach Packaging design Target

UNITS: Per Year

**Packaging design Target** = 0,8

UNITS: Dimensionless

**POLICY SWITCH** = 0

UNITS: Dimensionless

DOCUMENT: policy switch = 1 turns the garbage fee (weight-based garbage fee system) policy on.

**Ratio Adequate Sorters to Total Sorters** = Adequate Sorters/ Population

UNITS: Dimensionless

DOCUMENT: fraction of people who sort their waste appropriately.

**Relative Fraction of Quality Sorted Wasted** = Fraction of Quality Sorted Waste/initial fraction of quality sorted waste

UNITS: Dimensionless

**Relative Garbage Fee** =

IF TIME > 2016 AND POLICY\_SWITCH > 0

THEN SMTH1 ("relative weight-based garbage fee"; 2)

ELSE "relative volume-based garbage fee"

UNITS: Dimensionless

**"relative volume-based garbage fee"** = "actual volume-based garbage fee"/"initial volume-based garbage fee"

UNITS: Dimensionless

DOCUMENT: shows garbage fee development over time relative to its' initial value.

**"relative weight-based garbage fee"** = SMTH3 ("actual weight-based garbage fee"/"Initial weight-based garbage fee"; 2)

UNITS: Dimensionless

DOCUMENT: shows garbage fee development over time relative to its' initial value.

**Sorting Adoption Fraction** = Initial Sorting Adoption Fraction\*Effect of Peer Pressure on Sorting adoption\*effect of garbage fee on change in sorting behavior\*effect of sorting complexity on change in sorting behavior

UNITS: Dimensionless

DOCUMENT: fraction of people adopting sorting habits under the influence of garbage fee or peer pressure.

**Sorting complexity** = effect of infrastructure factor on sorting complexity\*Effect of Packaging Design on sorting complexity

UNITS: Dimensionless

**Time to change behavior** = 1

UNITS: year

DOCUMENT: assumption

**Time to reach infrastructure Target** = STOPTIME-STARTTIME

UNITS: year

DOCUMENT: it takes entire simulation period to reach the target (here 36 years).

**Time to reach Packaging design Target** = STOPTIME-STARTTIME

UNITS: year

DOCUMENT: it takes entire simulation period to reach the target (here 36 years).

\*\*\*\*\*

Waste generation:

\*\*\*\*\*

**Effect of sorted waste on waste per person** = (Fraction of Quality Sorted Waste/initial fraction of quality sorted waste) ^ elasticity of sorted waste on waste per person

UNITS: Dimensionless

DOCUMENT: an assumption made that the more people sort their waste the more they will dispose of compensating for the environmentally friendly behavior.

**Elasticity of sorted waste on waste per person = 0,03**

UNITS: Dimensionless

**Initial waste per person = 0,417**

UNITS: ton/person/year

DOCUMENT: in 1998 each citizen generated 417 kg of waste.

**Population(t) = Population (t - dt) + (net change in population) \* dt {NON-NEGATIVE}**

INIT Population = 282892

UNITS: people

DOCUMENT: Population BIR represents the number of inhabitants in the municipalities owned by BIR.

Initial value source: statistics from BIR

INFLOWS:

Net change in population = Population\*reference fractional growth rate

UNITS: people/years

**Reference fractional growth rate = 0,01**

UNITS: 1/year

DOCUMENT: Relative change in the number of inhabitants in BIR 1999-2019 (Statistics Norway).

**Reference Total waste generated = GRAPH(TIME)**

(1999,00, 121080), (2000,00, 126476), (2001,00, 129750), (2002,00, 133351), (2003,00, 138526), (2004,00, 131610), (2005,00, 135159), (2006,00, 135555), (2007,00, 139544), (2008,00, 138829), (2009,00, 127101), (2010,00, 125499), (2011,00, 135676), (2012,00, 137939), (2013,00, 148890), (2014,00, 152000), (2015,00, 157357), (2016,00, 152772), (2017,00, 155287), (2018,00, 151867)

UNITS: ton

DOCUMENT: 365 000 people live in the 9 municipalities (BIR.no)

HH waste generation per capita 420 kg per year (SSB.no)

**Reference waste per person = GRAPH(TIME)**

(1999,00, 0,428), (2000,00, 0,44), (2001,00, 0,447), (2002,00, 0,455), (2003,00, 0,468), (2004,00, 0,44), (2005,00, 0,4397), (2006,00, 0,435), (2007,00, 0,443), (2008,00, 0,436), (2009,00, 0,391), (2010,00, 0,379), (2011,00, 0,404), (2012,00, 0,405), (2013,00, 0,43), (2014,00, 0,432), (2015,00, 0,442), (2016,00, 0,425), (2017,00, 0,43), (2018,00, 0,417), (2019,00, 0,418), (2020,00, 0,419), (2021,00, 0,417), (2022,00, 0,42), (2023,00, 0,42), (2024,00, 0,42), (2025,00, 0,419), (2026,00, 0,418), (2027,00, 0,418), (2028,00, 0,418), (2029,00, 0,419), (2030,00, 0,419), (2031,00, 0,42), (2032,00, 0,42), (2033,00, 0,42), (2034,00, 0,42), (2035,00, 0,42)

UNITS: ton/person/year

DOCUMENT: Per capita waste generation rate

Assumption: the rate will remain approximately 0,420 after 2018.

**Waste per person = initial waste per person\*effect of sorted waste on waste per person**

UNITS: ton/person/year

## Appendix II: Interviews

### Part A: interview in person with the citizens

To better understand the sorting behavior of the citizens in Bergen municipality 20 respondents were asked in a personal conversation the following questions about waste sorting:

1. Do you sort your waste?
  
2. If yes, what makes you sort waste? With the following answering options:
  - I want to see myself as a responsible person
  - I want others to see me as a responsible person
  - I should do what I want others to do
  - Sorting is economically profitable for me
  
3. do you know how much you pay for the waste services?  
  
\_No. \_Yes, \_\_\_Kr
  
4. What kind of fee system is related to the waste system in your municipality?



## Part B: Interview in person with BIR

The interview took place in the BIR headquarters and four persons attended the meeting: Toralf Igesund (Head of planning department at BIR AS in Bergen), Ingrid Hitland (Managing director at BIR Avfallsenergi AS), Anaely Aguar (PHD student SD group), interviewer.

Toralf: price of recovered materials and price of energy are completely independent from each other. Price of metals goes up and down with variations on metal exchange.

BIR owned by 9 municipalities. EU commission sets regulations. Landfilling has been forbidden since 1998. Before landfilling ban came BIR decided to build an incinerator. Residual waste goes to incinerator.

When you burn waste, you have fly ash (full of hazardous chemicals) + bottom ash which is full of metals. And we collect those metals (for recycling) and sell them (when prices are high) because it is money for the company. The price goes up and down according to the metal exchange in London.

Electricity prices: incinerator plant has to 2 generators that produce electricity. And we sell that electricity. Prices (nve.no) vary with the seasons and weather conditions (rain, amount of snow etc.). Today the price for electricity is very high. Ingrid sells the electricity and follows the prices carefully.

There are 2 lines inside the big plant. Sometimes we close them for service. You cannot store HH waste, you need to constantly burn the waste. We can sometimes store industrial waste for some time outside the facility.

In summer we don't want to burn much, whereas in wintertime we want to produce a lot of energy. When the demand is high, and prices are high.

Import from GB. Waste comes either from other municipalities or from abroad. Ingrid bids for waste. Waste comes in bales so that you can store it and burn when you need.

Ingrid:



BIR has no sorting facility. Yes (we sort paper waste and send it away) and no (for municipal waste). Regarding plastic waste: we take out obviously wrong items and send the wastes away. We have not decided to build this facility in Bergen. We want people to sort their waste.

Me: Do you want people to sort their waste better? Do You care?

Ingrid: we do care, because then it can be converted into new materials. There is no conflict between recycling and incineration because it is enough waste to burn.

interviewer: All the materials that can be recycled go to recycling and not to the incinerator to cover the capacity.

Ingrid: no.

Toralf: no, but the question you ask is very common. We think that high quality is the most important factor when it comes to recycling. If you look only at a sorting fraction, then you are not so interested in quality. Quality is more important than quantity.

the interviewer: Do you want to improve the sorted fraction?

Toralf: maybe we are recycling less but of high quality.

Me: Is there a Recycling facility in Norway?

Toralf: we collect mixed quality; we have obvious mistakes (a cooking pan in a plastic container). We have some experts, some of them care some of them do not. We provide the experts with info. The first step is to get rid of obvious mistakes and then we send it to other parts of Norway, Germany or Sweden.

Ingrid: there are some companies that want to achieve highest recycling rate but that doesn't make it clean. We tell people to sort waste.

Toralf: We should not really focus on plastics recycling because at the moment recycling works really bad because the producers have no incentives to make plastics that are easy to recycle. Let us talk about aluminum (cans). We have the deposit refund system. You can recycle aluminum and metals many times. So, for metals we already have circular economy, but for plastics we have a long way to go. We have to work other places - start design for recycling, what we call "packers and fillers" (dairy, coca cola). If they use plastic bottles, they should be incentivized to use materials that are easy to recycle.

There is no EPR for paper in Norway. It is up to us to collect it and send it to paper mill and they mix it with new materials for paper production. We get paid for the paper we collect. You can recycle paper a few times but then you need to add new fibers in order to keep recycle the materials.

We have a sorting facility, not a recycling facility. There are two bins outside a house – for paper (we collect it once a month) and residue + big bag for plastics (goes with paper but separated at the facility). Stations for glass and metals and plastics. Residue right to the oven, then metals are extracted from ashes. The plant is very expensive (sorting). We in Bir are very reluctant to go into that (to invest in that kind), we will concentrate on quality.

When organic waste is taken out, we will still have enough waste to burn. About 30 % is food waste, paper, plastic, metal (a little bit). When we ask household to take out food waste, they won't take everything. If food waste is separated that can improve quality of other waste but it will still be not perfect to separate it to increase recycling fraction. There are different mixed waste types you cannot recycle (what do you do with an old shoe, how do you recycle that?)

How many people sort

Ingrid: most people sort but some of them sort poorly. We want them to sort more.

Toralf: They have economic incentives to reduce their waste. Recycling stations for bulky waste. If you reduce the amount of your residual waste, you pay less fee.

More incinerated less sorted (customers response on incineration)?

Ingrid: no, it is the other waste around – highest recycling rates are in the countries which incinerated their waste. You have to incinerate something that should not go to recycling. The only things we landfill now is ashes, tires and concrete.

Carbon is taken out.

In 1999 the 1 plant was open. The capacity was 120 000 tones residual waste per year, 2010 year: capacity has doubled. Half of the capacity is used for municipal waste BIR; another half is for commercial and waste from other part of Norway.

Recycling stations: furniture, electrical, chemicals (very expensive but we do it anyway),

No plans to expand capacity. We deliver everything we produce. The district heating companies use different types of energy. In summer we reduce capacity utilization. We store energy (not much) in pipes. Hot water, we are going to build a thermos to store energy (timber wood). So that we have more energy in the winter, we can close for summer this oven.

No coal burners in Norway, energy, hot water, electricity. We make our own electricity and sell to companies.

We are not afraid of recycling because recycling helps to avoid landfilling.

GB pays Bir for incineration. a Gate fee (charging other to burn their waste). We have no capacity to import more, we are full. Sweden is a great importer of waste. It is a free market. countries that does not have incinerators export their waste to the countries that have. If there is no import export should not take place. We balance our demand. We have some extra bails in case we need them.

### Appendix III: List of figures

Figure 1: Historical and projected recycling rates of municipal solid waste in Norway (1995-2035)

Figure 2: Recycling rate of municipal solid waste, BIR

Figure 3: Lansink's ladder

Figure 4: a stock-and-flow diagram of the waste generation sector

Figure 5: effect of peer pressure on change in sorting behavior: the more adequate sorters the greater the peer pressure effect.

Figure 6: Recycling behavior

Figure 7: waste streams between incinerator plant and material recycling

Figure 8: CLD

Figure 9: boundary chart

Figure 10: zero waste per person condition

Figure 11: zero waste per person condition

Figure 12: Behavior of Stock of Adequate sorters: reversion fraction = 1.

Figure 13: Behavior of Stock of Non- Adequate sorters: reversion fraction = 1.

Figure 14: “Non-Adequate Sorters (initial value)” test for “effect of peer pressure on sorting adoption”

Figure 15: Sorted out recyclables to incineration sensitivity test for Normal fraction of end-of-life materials

Figure 16: Sorted out recyclables to incineration sensitivity test for Elasticity of sorted waste to end-of-life materials

Figure 17: Waste per person sensitivity test for Elasticity of sorted waste on waste per person.

Figure 18: Adequate sorters sensitivity test for elasticity of packaging design to sorting complexity

Figure 19: base run: waste generation phase

Figure 20: balancing loop (economic incentive) and reinforcing loop (social norm)

Figure 21: base run: change in households' sorting behavior and number of sorters.

Figure 22: base run: fraction of quality sorted waste

Figure 23: Policy resistance loop

Figure 24: base run: change in household's recycling behavior

Figure 25: base run: fraction of waste treated based on treatment method

Figure 26: actual volume-based garbage fee  
Figure 27: Households sorting costs and Adequate sorters  
Figure 28: motivated and disappointed citizens  
Figure 29: Fraction of quality sorted waste  
Figure 30: flat rate garbage fee scenario: Non-Adequate sorters and fraction of quality sorted waste  
Figure 31: Garbage fee Policy. Adequate sorters and fraction of quality sorted waste  
Figure 32: policy: increased infrastructure capacity  
Figure 33: Infrastructure policy ON. Sorting cost and complexity  
Figure 34: Infrastructure policy. Sorting costs  
Figure 35: Infrastructure policy. Fraction of quality sorted waste  
Figure 36: Packaging design policy. Sorting behavior  
Figure 37: Fraction of quality sorted waste. Packaging design policy.  
Figure 38: Fraction of quality sorted waste. Packaging policy ON, change in the effect HH sorting costs on reversion rate  
Figure 39: sensitivity of Infrastructure policy to change in effect of crowding on households' sorting cost  
Figure 40: fraction of quality sorted waste. Infrastructure policy  
Figure 41: Policy outcomes compared to the base run  
Figure 42: effect of crowding on households' cost  
Figure 43: effect of relative garbage fee on change in sorting behavior  
Figure 44: Effect of HH sorting cost on change in reversion rate  
Figure 45: Effect of Peer Pressure on Sorting adoption  
Figure 46: effect of ratio adequate sorters on fraction of quality sorted waste  
Figure 47: effect of sorting complexity on change in sorting behavior

Table 1: Parameter confidence assessment

Table 2: “Non-Adequate Sorters “initial value” sensitivity test values

Table 3: “Normal fraction of end-of-life materials” sensitivity test values

Table 4: Elasticity of sorted waste to end-of-life materials sensitivity test values

Table 5: “Elasticity of sorted waste on waste per person” sensitivity test values

Table 6 : “Elasticity of packaging design to sorting complexity” sensitivity test values

Table 7: motivated and disappointed sorters, % difference

Table 8: fraction of quality sorted waste: policy combinations

## 8. References

- A. Allers, M., & Hoeben, C. (2010). Effects of Unit-Based Garbage Pricing: A Differences-in-Differences Approach. *Environmental and Resource Economics*, 45(3), 405-428. Retrieved from <https://doi.org/10.1007/s10640-009-9320-6>. doi:10.1007/s10640-009-9320-6
- Bala, B. K., Arshad, F. M., & Noh, K. M. (2017). *System Dynamics Modeling and Simulation*.
- Barlas, Y. (1996). Formal Aspects of Model Validity. *System Dynamics Review*, 12(3).
- BIR. (2017). Waste statistics, residual waste breakdown Retrieved from <https://bir.no/om-bir/årsrapport-2017/lovpaalagte-renovasjonstjenester/avfallsstatistikk-grafer/>
- BIR. (2018). This is BIR. Retrieved from <https://bir.no/om-bir/english>
- Brekke, K. A., Kipperberg, G., & Nyborg, K. (2010). Social Interaction in Responsibility Ascription: The Case of Household Recycling. *Land Economics*, 86(4), 766-784. Retrieved from <Go to ISI>://WOS:000282411700008  
<http://le.uwpress.org/content/86/4/766>. doi:10.3368/le.86.4.766
- Cleveland, C. J., & Morris, C. (2006). *Dictionary of energy*(1st ed. ed.).
- Dace, E., Bazbauers, G., Berzina, A., & Davidsen, P. I. (2014). System dynamics model for analyzing effects of eco-design policy on packaging waste management system. *Resources, Conservation and Recycling*, 87, 175-190. doi:10.1016/j.resconrec.2014.04.004
- Dai, Y. C., Gordon, M. P. R., Ye, J. Y., Xu, D. Y., Lin, Z. Y., Robinson, N. K. L., . . . Harder, M. K. (2015). Why doorstepping can increase household waste recycling. *Resources, Conservation and Recycling*, 102, 9-19. Retrieved from <http://www.sciencedirect.com/science/article/pii/S0921344915300215>. doi:<https://doi.org/10.1016/j.resconrec.2015.06.004>
- European Commission. (2015). Closing the loop - An EU action plan for the Circular Economy. Retrieved from <https://eur-lex.europa.eu/legal-content/EN/TXT/?uri=CELEX:52015DC0614>
- European Commission. (2016, June 09). Waste Framework Directive. Retrieved from <http://ec.europa.eu/environment/waste/framework/>

- Eurostat. (2018). Waste statistics. Retrieved from <https://ec.europa.eu/eurostat/statistics-explained/pdfscache/1183.pdf>
- Eurostat. (2018, August 17). Recycling rate of municipal waste. Retrieved from [https://ec.europa.eu/eurostat/tgm/table.do?tab=table&init=1&language=en&pcode=t2020\\_rt120&plugin=1](https://ec.europa.eu/eurostat/tgm/table.do?tab=table&init=1&language=en&pcode=t2020_rt120&plugin=1)
- Goodland, R., & Daly, H. (1996). Environmental Sustainability: Universal and Non-Negotiable. *Ecological Applications*, 6(4), 1002-1017. Retrieved from <http://www.jstor.org/stable/2269583>. doi:10.2307/2269583
- Halvorsen, B., Kipperberg, G. *Household recycling of different materials in Norwegian municipalities.*
- Harrison, K. W., Dumas, R. D., Solano, E., Barlaz, M. A., Brill, E. D., & Ranjithan, S. R. (2001). Decision support tool for life-cycle-based solid waste management. *Journal of Computing in Civil Engineering*, 15(1), 44-58. Retrieved from <Go to ISI>://WOS:000165956600007. doi:Doi 10.1061/(Asce)0887-3801(2001)15:1(44)
- Holmgren, K., Henning, Dag. (2004). Comparison between material and energy recovery of municipal waste from an energy perspective. *Resources, Conservation and Recycling*, 43(1), 51-73. doi:10.1016/j.resconrec.2004.05.001
- Kaza, S. Y., Lisa C.; Bhada-Tata, Perinaz; Van Woerden, Frank. (2018). *What a Waste 2.0: A global Snapshot of solid waste managment to 2050.* . Washington, DC: World Bank.
- Kjær, B. (2013). Municipal Solid Waste Management in Norway.
- Milios, L., Holm Christensen, L., McKinnon, D., Christensen, C., Rasch, M. K., & Hallstrom Eriksen, M. (2018). Plastic recycling in the Nordics: A value chain market analysis. *Waste Manag*, 76, 180-189. Retrieved from <https://www.ncbi.nlm.nih.gov/pubmed/29599024>. doi:10.1016/j.wasman.2018.03.034
- Norwegian Environment Agency. (2016). Waste. Retrieved from [https://www.environment.no/contentassets/a39b783e92274415b16c3e2cc1105c6c/rapport\\_en.pdf](https://www.environment.no/contentassets/a39b783e92274415b16c3e2cc1105c6c/rapport_en.pdf)
- Rahmandad, H., & Sterman, J. D. (2012). Reporting guidelines for simulation-based research in social sciences. *System Dynamics Review*, 28(4), 396-411. doi:10.1002/sdr.1481



- Recycling.com. (2012). Waste Hierarchy - Lansink's Ladder. In.
- Schultz, P. W., Oskamp, S., & Mainieri, T. (1995). Who Recycles and When - a Review of Personal and Situational Factors. *Journal of Environmental Psychology*, 15(2), 105-121. Retrieved from <Go to ISI>://WOS:A1995TA44700002. doi:Doi 10.1016/0272-4944(95)90019-5
- Statistics Norway. (2019, April 3). Waste accounts. Retrieved from <https://www.ssb.no/en/natur-og-miljo/statistikker/avfregno/aar>
- Sterman, J. D. (2000). Business dynamics: systems thinking and modeling for a complex world.
- Thøgersen, J. (1994). Monetary incentives and environmental concern. Effects of a differentiated garbage fee. *Journal of Consumer Policy*, 17(4), 407-442. Retrieved from <https://doi.org/10.1007/BF01022912>. doi:10.1007/bf01022912
- Thomas, C., & Sharp, V. (2013). Understanding the normalisation of recycling behaviour and its implications for other pro-environmental behaviours: A review of social norms and recycling. *Resources, Conservation and Recycling*, 79, 11-20. Retrieved from <http://www.sciencedirect.com/science/article/pii/S0921344913000979>. doi:<https://doi.org/10.1016/j.resconrec.2013.04.010>
- Ulli-Beer, S., Andersen, D. F., & Richardson, G. P. (2007). Financing a competitive recycling initiative in Switzerland. *Ecological Economics*, 62(3-4), 727-739. Retrieved from <Go to ISI>://WOS:000247080100034 <https://www.sciencedirect.com/science/article/pii/S0921800906004666?via%3Dihub>. doi:10.1016/j.ecolecon.2006.09.017
- Valerio, F. (2010). Environmental impacts of post-consumer material managements: recycling, biological treatments, incineration. *Waste Manag*, 30(11), 2354-2361. Retrieved from <https://www.ncbi.nlm.nih.gov/pubmed/20573498>. doi:10.1016/j.wasman.2010.05.014

