

Paper accepted for publication in Journal of Hazardous Materials with minor revisions

Title:

“Measurement of minimum ignition energies of dust clouds in the < 1 mJ region”

Authors:

Erlend Randeberg (corresponding author) and Rolf K. Eckhoff

Affiliation:

Department of Physics and Technology, University of Bergen, Allégaten 55, N-5007 Bergen,
Norway

Address of corresponding author:

Department of Physics and Technology, University of Bergen

Allégaten 55, N-5007 Bergen, Norway

Tel: +47 55 58 94 07, fax: +47 55 58 94 40

E-mail: erlend.randeberg@ift.uib.no

Type of article:

Research paper

Abstract

The lower energy limit of current standard test apparatus for determining the minimum ignition energy (MIE) of dust clouds is in the range of 1-3 mJ. This is a quite severe limitation because many dusts ignite readily at this energy level. A new spark generator, capable of producing synchronised sparks of very low energies and with an integrated system for measurement of spark energy, has therefore been developed and employed to a number of easily ignitable dusts.

Before testing the MIE of dust clouds, it was considered essential to calibrate the new spark generator against a gas of known MIE. For this purpose, a mixture of propane and air was selected. However, a comprehensive literature review revealed that the reported MIEs of this gas mixture vary significantly, depending on the spark discharge characteristics, including discharge duration. When taking these factors into account, it was concluded that the new spark generator yielded reasonable results for propane/air.

Applying the new spark generator to explosive dust clouds showed that a number of dusts do in fact have MIEs that are 1-2 orders of magnitude lower than 1 mJ. The new spark generator may therefore offer a basis for developing a standard test apparatus in the low-energy region.

When using a method of triggering the spark by the explosive dust cloud itself, which probably is a more industrially relevant process than synchronisation between the dust dispersion and sparkover, somewhat higher MIEs were found compared to those determined when using synchronised sparks. However, even with this method of spark triggering, MIEs below 1 mJ were found.

Keywords:

Minimum ignition energy; Dust explosion; Spark generator

1 Introduction

Accidental dust explosions are a major concern in many industries handling combustible dusts [1]. In a hazard evaluation, the minimum ignition energy (MIE) is a central parameter, indicating the lower energy limit of sparks capable of igniting the dust cloud. Until about 1975, it was believed that MIEs for all dust clouds were above 10 mJ. With a spark generator capable of producing sparks of lower energies, however, Eckhoff [2] found that dust clouds could have MIEs of about 1 mJ. In the present paper, even lower MIEs are investigated, using sparks with energies that are two orders of magnitude lower.

Current standard tests for determination of MIE of dust clouds have several shortcomings when it comes to the industrial relevance of the results produced in the laboratory.

The primary objection is the fact that sparks with energies below 1 mJ are not available in current standard tests [3, 4]. Precise knowledge about ignition energies for dust clouds below this value is therefore limited. Several gases have MIEs significantly below 1 mJ, reported e.g. by Lewis and von Elbe [5]. Experimental ignition of quiescent gases is, however, significantly different from the ignition of a transient dust cloud. Because of gravitational settling of the dust particles, the ignition source must be triggered at a point in time when the dust concentration is within the explosive limits, and synchronisation between the generation of a transient dust cloud (dust dispersion) and sparking is essential when investigating the MIEs of dust clouds. The synchronisation represents a major challenge when working with low energy capacitive sparks, and this is reflected in the energy limit of current standard tests. The main reason is that switches and other circuit elements tend to introduce additional energy to the spark.

Routine testing has revealed that a significant fraction of industrial powders/dusts are found having MIEs below 1 mJ, but the true values remain unknown. However, using equipment different from the standard apparatus, but without giving any details about the

discharge circuit, Bartknecht [6] reported MIE values of 0.1 mJ for aluminium and 0.01 mJ for sulphur.

A secondary objection to the industrial relevance of present standard MIE tests is that the explosive dust cloud is dispersed independently of the spark. This is probably quite different from the practical industrial situation, and thus very conservative with regards to safety limits. In practice, synchronisation of dust cloud and spark discharge is probably achieved by the dust cloud itself acting as the trigger of the spark. When the dust particles enter a spark gap with a preset static high voltage, breakdown may be triggered with a subsequent spark discharge. This process has been investigated by Randeberg and Eckhoff [7], and as opposed to conventional MIE tests the delay between dust dispersion and sparkover is not a degree of freedom. In fact, this process of synchronisation offers an alternative test method that may be more similar to what takes place when electrostatic sparks cause ignition in industry. However, using this method of spark triggering generally yields MIE values somewhat higher than those from conventional tests.

On the other hand, a new spark generator developed by Randeberg *et al.* [8] offers the opportunity to generate capacitive sparks that can be synchronised with the dust cloud, also in the energy range below 1 mJ. This enables MIE testing similar to the conventional methods even in the < 1 mJ range, down to about 0.03 mJ.

The scope of the present paper is to present MIE values for easily ignitable dusts using both the method of electronic synchronisation of dust dispersion and sparkover, and the method of spark triggering by the explosive dust cloud itself. In addition, an investigation of MIE for mixtures of propane and air using the new spark generator has been performed, enabling calibration of the spark generator by comparison of MIE data with literature values.

2 Experimental

2.1 Explosion vessel

The mechanical parts of the explosion vessel and dispersion system are similar to the MIKE apparatus from Kühner [9], and are previously described in detail by Randeberg and Eckhoff [7]. The dust is dispersed by opening a valve and emptying a 50 cm³ pressurised air reservoir at 7 bar(g), as shown in Figure 1. In most of the tests the dust was placed in a dust reservoir downstream of the air reservoir, forcing the particles through the nozzle, thus reducing agglomeration. However, some of the dusts had to be placed in the bottom cup of the explosion chamber because of clogging of the pipe and nozzle.

When doing ignition tests with propane gas, a gas mixing arrangement was used. By adjustment of the flows of propane and air, the gas concentration was monitored by a gas analyser (*Servomex 1400*). When the propane concentration of the gas flowing into the explosion chamber was equal to that of the gas flowing out of the chamber at the top, the concentration inside the explosion chamber was considered to have the same value. All experiments were done at room temperature and atmospheric pressure.

2.2 Spark generator and energy measurement system

The new spark generator used in the present experiments yields low-energy capacitive sparks, similar to the ones resulting from electrostatic discharges. An integrated system for measurement of spark voltage and current as functions of time offers the opportunity to determine the spark energy. Sparks are generated by using a high voltage pulse to charge a discharge capacitor, which is subsequently discharged when the breakdown voltage of the electrode gap is reached. A charging resistor is used to ensure that no significant amount of energy is supplied to the spark during its lifetime.

The spark voltage is measured using a high-voltage probe (*Tektronix P6015*), and the current is measured differentially using two conventional scope probes across the current measurement resistors. The spark energy is taken as the product of spark current and voltage,

integrated over the duration of the spark, typically about 0.1 μs , minus energy losses to the current measurement resistors. The resistive losses become increasingly significant with increasing capacitance and spark current. The net spark energy is used in the present tests, unlike conventional testing where the stored capacitor energy $\frac{1}{2} CV^2$ is stated equal to the spark energy. This represents no large discrepancy, however, since the measured spark energies were typically 60-90 percent of the capacitor energy $\frac{1}{2} CV^2$, when the maximal voltage V before breakdown was used as input. Sparks with energies between about 0.03 and 10 mJ can be generated with the present spark generator. Prolonged sparks are not available because no inductance can be added in the discharge circuit.

The spark generator gave erroneous ignition energies if the time constant RC , where R is the charging resistor and C the discharge capacitance, was too small. In such cases, the discharge capacitor would be recharged during the time of spark discharge, and the integrated spark energy would continue to increase beyond about 0.1 μs . The time constant of the charging circuit should typically be at least 1 μs to avoid this effect, and this could be easily checked by ensuring that the integrated energy stabilises after some 100 ns.

The schematic layout of the discharge circuit is shown in Figure 2. The electrodes are made of 2 mm diameter tungsten rods, sharpened to an angle of approximately 60° . The electrode gap was one of the parameters that could be varied between tests. Further details about the discharge circuit and spark energy system are given by Randeberg *et al.* [8].

2.3 Spark triggering by the explosive dust cloud

The transient dust cloud may trigger breakdown between electrodes preset at a static high voltage somewhat below the breakdown voltage in pure air. When dust is dispersed into the electrode gap, a discharge may be initiated, the voltage needed depending somewhat on the dust and concentration in question. The circuit is much simpler than the circuit described in section 2.2. To avoid multiple sparking, a large charging resistor is included, ensuring that the time constant RC of the charging of the discharge capacitor is significantly larger than the

lifetime of the transient dust cloud, i.e. of the order of 100 ms. In this case, the spark energy is assumed equal to the stored capacitor energy $\frac{1}{2} CV^2$, where V is the preset voltage. If spark discharge is triggered by the dust cloud, the oscilloscope detects a peak signal through a simple capacitive coupling to the discharge circuit. The schematic layout of the circuit is shown in Figure 3. There is no added series inductance, which is different from conventional tests, where an inductance can be added in series with the discharge capacitor to produce prolonged sparks. To avoid the occurrence of corona discharge prior to breakdown, the pointed 2 mm diameter tungsten electrodes were rounded off.

Further details about the circuit and the method of spark triggering are given in [7].

2.4 Procedures for MIE tests

A number of dusts known to have low MIEs were chosen for the present experiments. In addition, propane was chosen to enable comparison with published MIEs of a well-documented substance.

When using the new spark generator, capable of providing synchronised sparks, the measured spark energy varied somewhat between tests because of some scattering of the breakdown voltage. Therefore, it was not possible to do several ignition trials at precisely predetermined spark energy. The procedure for the ignition trials was thus to select a discharge capacitance and an electrode gap, and measure the spark energy in each test. To establish MIEs the tests were done by starting at a relatively high spark energy level, i.e. a relatively large discharge capacitor was used. The capacitance was then reduced in steps until no ignitions occurred for ten ignition trials, or until it could not be reduced any further. The nominal dust concentration was also varied, offering the opportunity to find the ideal conditions for spark ignition of the dust cloud at trial. The same applies to the preset delay between dust dispersion and sparkover.

When using the method of triggering the spark by dispersion of the dust cloud, the spark energy was assumed equal to the stored capacitor energy. Ten ignition trials were performed at the same energy level, the voltage being preset at a level somewhat below breakdown in

pure air. If a spark discharge was not triggered by the dust cloud, the trial was discarded and the procedure repeated until a spark occurred. In these experiments, the nominal dust concentration (quantity of dust dispersed divided by the volume of the explosion chamber) was varied, but the delay between dispersion and sparkover was beyond control.

Gas ignition experiments were carried out using the new spark generator described in section 2.2, for a wide range of concentrations of propane in air. The spark energy and whether the spark ignited the gas were recorded for each trial.

3 Results and discussion

3.1 Ignition of propane/air mixtures

Figure 4 shows the results from the spark ignition tests with premixed propane/air. The solid U-shaped curve is an estimated border between ignition and no-ignition, indicating MIE as a function of propane concentration. It should be noted, however, that no spark ignition tests resulted in no-ignition at near-stoichiometric concentrations because of the energy limitations of the spark generator used and the prevailing test conditions. Thus, it was not possible to establish precise minimum ignition energies at these concentrations.

In addition to the data from the present investigation, literature data on MIE of propane/air have been added to the figure. The investigations of spark ignition of various gases described by Lewis and von Elbe [5] are frequently referred to as an absolute standard when dealing with minimum ignition energies of combustible gases. Using a similar spark generator circuit Calcote *et al.* [10] found MIE values in close agreement with Lewis and von Elbe's data. The resistance in the discharge circuits used by these workers was very small, and the energy losses are claimed to be less than one percent of the stored capacitor energy [10]. The criterion for ignition was a probability of one percent.

Dietlen [11] also found ignition energies, without giving any details on the ignition criterion, for a range of concentrations of propane. The values were about a factor of four higher than those reported by Lewis and von Elbe. Dietlen ascribes this to quenching because

of the relatively short electrode gaps used. A three-electrode discharge circuit with a system for measurement of voltage and current was used, enabling energy measurement by integration of the power versus time of the capacitive discharge. However, the discharge circuit inductance was reported to be frequency-dependent, which indicates a capacitive and/or resistive component in the series element added. This may have influenced the energy measurements.

Using an 80 percent ignition probability criterion, Moorhouse *et al.* [12] also determined MIEs for propane/air as a function of propane concentration. The values found were about a factor of two to four higher than the Lewis and von Elbe values, with the smallest deviation at propane concentrations near stoichiometric. The difference in ignition probability criterion may be a part of the explanation of the deviation. Sparks were generated using an expanding capacitor plate technique, enabling high voltage discharges from a capacitor initially charged at a relatively low voltage. The spark energy was assumed equal to the capacitor energy at breakdown.

Kono *et al.* [13] determined MIE for three lean concentrations of propane in air as a function of the duration of the spark. The spark generator produced composite sparks with an initiating capacitive discharge and a subsequent discharge component of variable duration. The spark energy was taken as the sum of the energy of the capacitor prior to breakdown and the integrated power of the secondary component. The minimum ignition energies were based on a 50 percent ignition frequency criterion, indicating that the lowest spark energies causing ignition were even lower than the quoted MIE values. Even then, the reported values were less than half of those reported by Lewis and von Elbe.

Parker [14], using pulsed sparks, determined MIE at the optimal duration of the spark, for 2.7 percent propane in air with an ignition probability of 10 percent. The spark voltage and current were measured and the energy defined as the integral of power versus time. With a 4 mm electrode gap, the lowest spark energy yielding ignition was 0.3 mJ, whereas with a 2 mm gap and probably quenched it was 3 mJ. Direct comparison with Lewis and von Elbe's data cannot be made, because these workers only used propane concentrations above 3

percent. By extrapolating their curve, however, the MIE can be estimated to be between 3 and 10 mJ for 2.7 percent, which is an order of magnitude higher than Parker's value.

The deviation in reported MIE values shows that the "true" minimum spark ignition energy of propane in air is not uniquely defined, probably due to significant influences of the properties of the electrodes, gap distance, discharge circuits and spark energy estimation/measurement etc. In the investigations discussed here, relatively sharp electrodes were used, except by Lewis and von Elbe. However, because the gap between their flanged electrodes was above the quenching distance, this probably has a relatively little effect on the MIE values reported.

Different methods of spark energy estimation may account for part of the variation in reported MIEs. However, the deviation between capacitor energy prior to breakdown and integrated spark power of the spark generator used in the present experiments only accounts for about 10-40 percent. Lewis and von Elbe's MIE data is about a factor of six higher.

The method of spark generation and circuit properties may therefore be the most important factors when attempting to analyse why the MIEs are differing. The different phases of the discharge are known to have different abilities to cause ignition, with the rapid breakdown phase being the most efficient way of transferring electric energy to chemical ignition of gas mixtures [15, 16]. Parker [14] found that the ignition energy generally increased with increasing spark duration, from about 0.3 mJ for sparks of about 0.2 μs duration to 2 mJ at 100 μs . Kono *et al.* [13] found a minimum ignition energy at about 50 μs spark duration, with a slightly higher ignition energy for sparks of shorter duration. For sparks of longer duration the ignition energies were significantly higher.

Discharge times when using pure capacitive discharges, were measured by Moorhouse *et al.* [12], who found the duration of the damped current oscillation to be 1.2 μs . The circuit inductance was found to be 0.97 μH . Dietlen [11] measured a discharge time of about 0.2 μs for the smallest energies, but the spark energy measurements may be somewhat difficult to

relate to what other workers have reported. The other workers using capacitive discharges [5, 10, 12] did not report the circuit's inductance and discharge durations.

Because of a simple and compact design, the inductance of the discharge circuit used in the present investigations was as low as 0.095 μH and the discharge duration about 0.1 μs [8]. Thus, the discharges were very rapid and more dominated by the breakdown phase than for most other capacitive discharge circuits reported in the literature, probably making the energy release in the spark gap more efficient for ignition. When using a pulse circuit, Parker [14] assumed that the rapid dissipation of energy to the spark increased the efficiency of energy transfer. A similar effect may be the case in the present experiments, possibly explaining the deviation from other experiments where capacitive sparks were used.

When it comes to the practical relevance of the different spark generators used for ignition testing, however, comparison with sparks resulting from electrostatic discharges should be made. The duration of such discharges would usually be expected to be very short because of low circuit impedance, similar to the features of the spark generator used in the present experiments.

3.2 Dust cloud ignition by synchronised sparks

The Calibration-Round-Robin test CaRo 03 [17] offers a relevant reference for the ignition tests with the new spark generator of Figure 2. Conventional standard tests indicate an MIE of 1.7 mJ, with a conformity interval from 0.6 to 5.1 mJ for the niacin dust used. No laboratories reported an MIE below 1 mJ, in accordance with the fact that 1-3 mJ is the lower energy limit of standard test equipment. However, the lowest spark energy resulting in ignition in the present experiments was 0.54 mJ. This is slightly lower than the low energy limit stated in the test report, but indicates that the spark generator is in reasonable agreement with the circuits of conventional laboratory equipment. If the argument of short-duration sparks being more incendiary than sparks of longer duration holds even for dusts, a quite low MIE would be in agreement with expectation (see discussion in section 3.1). Figure 5 shows the frequency of ignition as histograms within each energy level. The white data points indicate ignition and

the black no-ignition. This data is also included in Figure 6, showing the ignition results of all dusts tested.

A number of zirconium, titanium and hydrides of these metal powders were supplied for the present experiments. The ignition energies of the powders in bulk were stated by the manufacturer [18], and these values offer a reference when assessing the ignition energies of the dust clouds.

Several zirconium (Zr) powders were tested using the new spark generator, but conclusive MIEs could not be found. It turned out that the powder was in fact ignited by the dispersion process itself, without any electric spark present. This is in accordance with previous investigations concluding that the minimum ignition temperature of Zr dust clouds was room temperature [19, 20]. The frictional forces involved in the dust dispersion probably accounts for the behaviour, as also concluded by Matsuda *et al.* [21]. The method of producing dust clouds by dispersion by an air blast is thus not suitable when assessing the ignition characteristics of Zr. The minimum ignition energies of dust layers of Zr dusts are found to be between 1.8 and 18 μJ [18], which is below the energy limit of the spark generator.

The ignitability of two titanium (Ti) dusts (labelled grade E and S) were also tested by use of the new spark generator. The minimum ignition energies of layers of these dusts were stated to be 0.32 and 1.0 mJ, respectively, whereas the average particle size was stated to be $3\pm 1 \mu\text{m}$ and $9.5\pm 1.5 \mu\text{m}$ [18]. However, when dispersed into dust clouds in air the same dusts exhibited significantly lower MIEs. Ti grade E was ignited at the lowest energies that the spark generator could yield, i.e. even as low as at 0.012 mJ. The Ti grade S dust could not be ignited at spark energies below 0.36 mJ. These results are in sharp contrast to the value of 10 mJ and upwards for dust clouds of different fractions and purities of Ti stated in [20]. In [19] the ignition energy is only stated to be less than 200 mJ. An important reason for the discrepancy may be the different spark generators used. In these two cases [19, 20] it was based on discharging a capacitor through a high voltage transformer to achieve spark discharges. Thus, a significant amount of energy may have been lost to the transformer.

Zirconium hydride (ZrH_2) and titanium hydride (TiH_2) with ignition energies for dust layers of 3.2 and 5.0 mJ, respectively, and average particle size of $2.6 \pm 0.6 \mu m$ and $1.8 \pm 0.2 \mu m$ [18] were also tested. The dust clouds were ignited by sparks of energies down to 0.13 and 0.19 mJ.

Furthermore, fine sulphur dust was ignited at spark energies down to 0.043 mJ. This value is the lowest that the generator could give. In comparison, Bartknecht [6] reported an MIE of 0.01 mJ for sulphur dust, without giving any details on the method or discharge circuit used. Eckhoff [2], on the other hand, was able to ignite the dust at 0.3 mJ, which was the lower energy limit of the spark generator. Using a break-flash spark generator, Bennett [22] found the MIE of sulphur dust to be similar to that of ethylene.

Fine aluminium flake dust was ignited down to spark energies of 0.018 mJ, which also was as low energy as the spark generator could provide. For this type of dust Bartknecht [6] reported an MIE of 0.1 mJ, whereas Eckhoff [2] was able to ignite Al flake dust at about 1 mJ.

A dust with product name SIBS-K32 is known to have an MIE lower than what could be tested for in the MIKE apparatus, i.e. below 1 mJ [23]. In the present tests, the dust could be ignited by sparks of energies down to 0.10 mJ.

Except for sulphur dust, ignition experiments using the new spark generator show much lower MIE values than previously reported in the literature. However, little data on MIEs of dust clouds below 1 mJ exists. The ignition energies of dust clouds were also significantly lower than the reported values of minimum ignition energies of layers for some of the metal dusts.

The present MIE values and comparison with previously published data are summarised in Table 1. The tabulated MIEs achieved in the present experiments are the lowest spark energies yielding ignition, but for all the dusts there is a relatively large energy range where the ignition frequency is somewhere between 0 and 100 percent, as illustrated in Figure 6.

For several of the dusts tested, the spark generator could not produce sparks of low enough energies to determine the low-energy limit of ignition. It is also worth noting that the type of dust involved affected the breakdown voltage, and thus the spark energy. Metallic dusts tended to reduce the breakdown voltage, probably because the conductive dust particles sticking to the electrodes reduced the spark gap.

For metallic particles, another behaviour was also striking. Because of problems of sparkover between the high voltage electrode and the dust-covered wall of the explosion vessel, the electrode holder had to be cleaned for dust between dispersions. This phenomenon was particularly pronounced when working with aluminium flake dust, which stuck to the electrodes and explosion vessel walls.

Throughout all the tests presented here, the electrode gap was 4 mm, and in some cases reduced to 2 mm in order to reduce the breakdown voltage and achieve the lowest spark energies. Kuchta [24] found that the quenching distances for several gases were approximately proportional to the square root of MIE. Hence, assuming that this correlation also applies to dusts, and the quenching distance for a dust of MIE = 100 mJ is 10 mm, the value for a dust of MIE = 1 mJ would be 1 mm. For the dusts tested in the present work, quenching is probably of little importance.

3.3 Dust cloud ignition by dust cloud triggering of the spark

When using the dust cloud itself as the trigger of the spark – i.e. using the discharge circuit in Figure 3 – different values for minimum ignition energies were achieved compared to when using synchronisation between dust dispersion and sparkover. For titanium grade E, the lowest spark energy – assumed equal to the capacitor energy $\frac{1}{2} CV^2$ prior to breakdown – giving ignition was 0.28 mJ, achieved with a spark gap of 5 mm. This is lower than what can be tested for in current conventional test equipment. However, the frequency of ignition at energies below some mJ is relatively low, indicating that the conditions for ignition are far from optimal. The difference between considering the net spark energy and the stored

capacitor energy only accounts for a small fraction of the difference in ignition energy of 0.012 versus 0.28 mJ.

The ignition energy for sulphur when using the dust cloud to trigger breakdown is previously found to be 2.3 mJ when using pure capacitive sparks [7]. Here the discrepancy in ignition energy is even more pronounced for the two methods – 0.043 versus 2.3 mJ – than for Ti dust. As the MIE tends to increase with increasing electrode distance above the quenching distance, the relatively large spark gap of 8 mm may be part of the explanation for the high MIE value of sulphur.

3.4 Relevance of MIE tests at low energies for assessment of electrostatic hazards in practice

By adjusting the delay between dust dispersion and sparkover, optimal concentration and turbulence at the time of ignition can be achieved. From a safety point of view, this represents a quite conservative method of finding the “safe” energy limits of potential electrostatic sparks in an industrial plant.

The method of using the dust cloud itself to trigger the spark discharge may be quite similar to what actually takes place when a dust cloud is ignited by an electrostatic spark in industry, as discussed in [7, 25]. However, because of non-optimised conditions for ignition, the minimum ignition energies are generally higher than when using synchronised sparks. As a test method, it may also be quite laborious because the preset voltage must be adjusted for each dust and spark gap, and trials when the spark is not triggered must be discarded.

On the other hand, because of the simplicity of the discharge circuit, low-energy sparks are easily available. By careful design of the capacitor and electrode arrangement, discharge capacitors of a few pF are within reach, offering the possibility to generate sparks of energies well below 1 mJ. A limiting factor is that the charging resistor must be impractically large ($\sim 10^{11} \Omega$) to avoid multiple sparking within the duration of the transient dust cloud.

When comparing the MIEs of easily ignitable dusts, using the method of spark triggering by the dust cloud itself and by synchronised sparks, the difference is found to be substantial. This is probably due to the non-optimal conditions for ignition in the former method. There is

therefore a clear need for synchronisation between dust dispersion and sparkover if the objective is to find the lowest ignition energies at all possible.

The method of synchronisation used in conventional standard tests, however, restricts the energy of the spark, and thus restricts our knowledge of ignition energies in the low-energy region. The new spark generator presented here can offer valuable information about minimum ignition energies of dust clouds in the very low-energy region.

4 Conclusions

1. A new spark generator, with an integrated system for spark energy measurement, has been developed for MIE testing of dust clouds in the range below 1 mJ.
2. Calibration of the new spark generator was done by comparing MIE values achieved for mixtures of propane and air with values reported in the literature. The significant variation in the MIEs previously reported is probably related to the differences in spark discharge characteristics, including discharge duration. It is therefore believed that the new spark generator yields reasonable results for propane/air.
3. A number of dust clouds were found to have MIEs of 1-2 orders of magnitude lower than the lower energy limit of current standard test apparatus. The new spark generator may be used as a basis for developing a standard test apparatus for determination of MIE of dust clouds in the very low-energy region.
4. MIE testing using synchronisation between dust dispersion and sparkover probably represents a quite conservative method compared to what actually takes place in an industrial plant. However, even when using a method of triggering the spark by the dust cloud itself, MIEs below 1 mJ could be found.
5. If the objective of the test is to determine the lowest ignition energies at all possible, synchronisation is essential.

Acknowledgements

This work was supported financially by the Research Council of Norway. The authors would like to thank Chemetall GmbH, Swiss Institute of Safety & Security, Carlfors Bruk AB and GexCon AS for supplying of some of the dusts used.

References

1. Eckhoff, R.K. (2003) *Dust explosions in the process industries*. 3rd ed, Boston: Gulf Professional Publishing/Elsevier.
2. Eckhoff, R.K. (1975) Towards absolute minimum ignition energies for dust clouds?, *Combust. Flame*, **24**, p. 53-64
3. CEN (2002) *Determination of minimum ignition energy of dust/air mixtures*, European Standard EN 13821, European Committee for Standardization, Brussels
4. IEC (1994) *Method for determining minimum ignition energies of dust/air mixtures*, IEC International Standard 1241-2-3, International Electrotechnical Commission, Geneva
5. Lewis, B. and G. von Elbe (1987) *Combustion, flames and explosions of gases*. 3rd ed, ed. B. Lewis and G. von Elbe, London: Academic Press.
6. Bartknecht, W. (1993) *Explosionsschutz*, Berlin: Springer-Verlag.
7. Randeberg, E. and R.K. Eckhoff (2006) Initiation of dust explosions by electric spark discharges triggered by the explosive dust cloud itself, *J. Loss Prevent. Proc.*, **19**, p. 154-160
8. Randeberg, E., W. Olsen, and R.K. Eckhoff (2006) A new method for generation of synchronised capacitive sparks of low energy, *J. Electrostat.*, **64**, p. 263-272
9. Cesana, C. and R. Siwek (2001) *MIKE 3. Minimum Ignition Energy*, Adolf Kühner AG, Birsfelden, Switzerland
10. Calcote, H.F., *et al.* (1952) Spark ignition. Effect of molecular structure, *Ind. Eng. Chem.*, **44**, p. 2656-2661
11. Dietlen, S. (1976) *Ermittlung der Mindestzündenergie brennbarer Gase in Mischung mit Luft*, BAM-Bericht Nr. 42, Der Bundestanstalt für Materialprüfung, Berlin
12. Moorhouse, J., A. Williams, and T.E. Maddison (1974) An investigation of the minimum ignition energies of some C₁ to C₇ hydrocarbons, *Combust. Flame*, **23**, p. 203-213
13. Kono, M., S. Kumagai, and T. Sakai (1976) The optimum condition for ignition of gases by composite sparks, in *Proc. of 16th Symp. (Internat.) on Combustion*: The Combustion Institute. p. 757-766
14. Parker, S.J. (1985) *Electric spark ignition of gases and dusts*, Ph.D. Thesis, The City University, London
15. Maly, R. and M. Vogel (1978) Initiation and propagation of flame fronts in lean CH₄-air mixtures by the three modes of the ignition spark, in *Proc. of 17th Symp. (Internat.) on Combustion*: The Combustion Institute. 821-831
16. Maly, R. (1984) *Spark ignition: Its physics an effect on the internal combustion engine*, in *Fuel economy in road vehicles powered by spark ignition engines*, J.C. Hilliard and G.S. Springer, Editors, Plenum Press: New York. p. 91-148.
17. Cesana, C. (2004) *Final Report. Calibration-Round-Robin CaRo 03, B052_185*, Adolf Kühner AG, Birsfelden, Switzerland
18. Wilfing, G. (2004) *Personal communication. Ignition energies of bulk powders*: Chemetall GmbH, Langelsheim, Germany.

19. Hartmann, I., J. Nagy, and H.R. Brown (1943) *Inflammability and explosibility of metal powders*, Report 3722, US Bureau of Mines, Washington
20. Jacobson, M., A.R. Cooper, and J. Nagy (1964) *Explosibility of metal powders*, Report 6516, US Bureau of Mines, Washington
21. Matsuda, T., *et al.* (2001) Some aspects in testing and assessment of metal dust explosions, *J. Loss Prevent. Proc.*, **14**, p. 449-453
22. Bennett, D., *et al.* (2003) A test for electrical ignitions of flammable dust clouds, *J. Loss Prevent. Proc.*, **16**, p. 33-40
23. Glor, M. (2005) *Personal communication. Information on MIE of the dust SIBS-K32*: The Swiss Institute of Safety & Security, Basel, Switzerland.
24. Kuchta, J.M. (1985) *Investigation of fire and explosion accidents in the chemical, mining and fuel related industries*, US Bureau of Mines, Pittsburgh, PA
25. Eckhoff, R.K. and E. Randeberg (2005) A plausible mechanism of initiation of dust explosions by electrostatic spark discharges in industrial practice, *VDI Berichte*, **1873**, p. 185-197

Tables

Table 1. Summarised MIEs for various dust clouds in air and comparison with previously reported MIE data.

Dust	MIE in the present tests (mJ)	MIE reported in earlier work (mJ)	MIE for dust layers (mJ)
CaRo 03	0.54	0.6-5.1 [17]	
Titanium grade E	< 0.012	} ~10 [20] < 200 [19]	0.32 [18]
Titanium grade S	0.36		1.0 [18]
Zirconium hydride	0.13		3.2 [18]
Titanium hydride	0.19		5.0 [18]
Sulphur	< 0.043	{ 0.01 [6]	
		{ 0.3 [2]	
Aluminium flakes	< 0.018	{ 0.1 [6]	
		{ 1 [2]	
SIBS-K32	0.10	< 1 [23]	

Figures

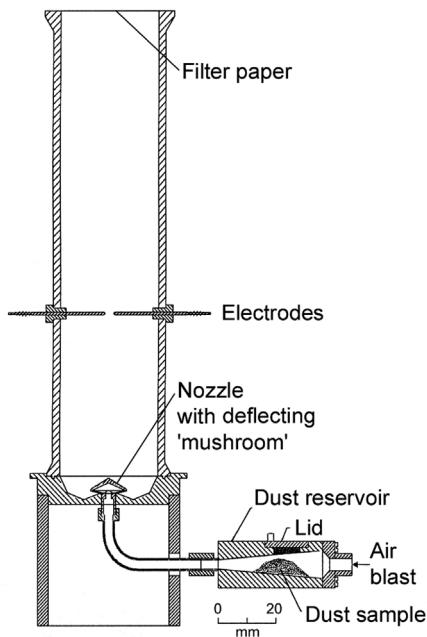

Figure 1. Cross-section of the dust dispersion system and explosion chamber. The air blast is generated by emptying a 50 cm³ pressurised air reservoir, fitted with a solenoid valve, upstream of the dust reservoir. Further details are given in [7].

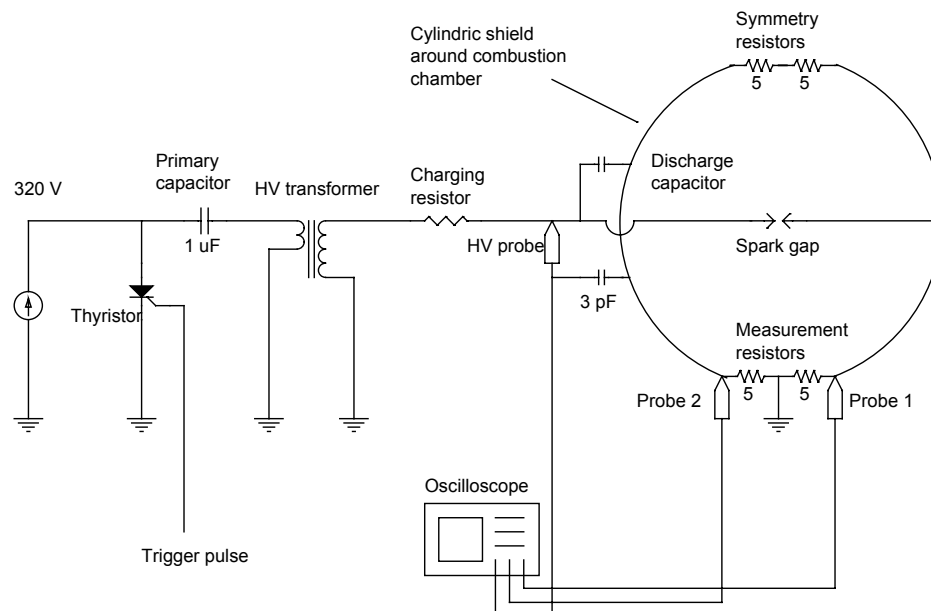

Figure 2. Schematic layout of the new spark discharge circuit and integrated spark energy measurement system. By triggering of the thyristor, sparks that can be synchronised with the dust dispersion are generated. Further details about the generator are given in [8].

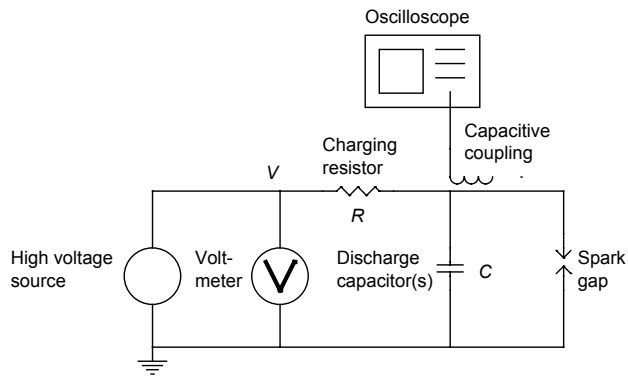

Figure 3. Schematic layout of the electric discharge circuit used when the explosive dust cloud itself triggers the spark discharge. The voltmeter is integrated in the high voltage source, measuring the output voltage V . The capacitive coupling is simply a wire twisted around the electrode, to ensure that the presence of a spark is recorded by the oscilloscope. Further details are given in [7].

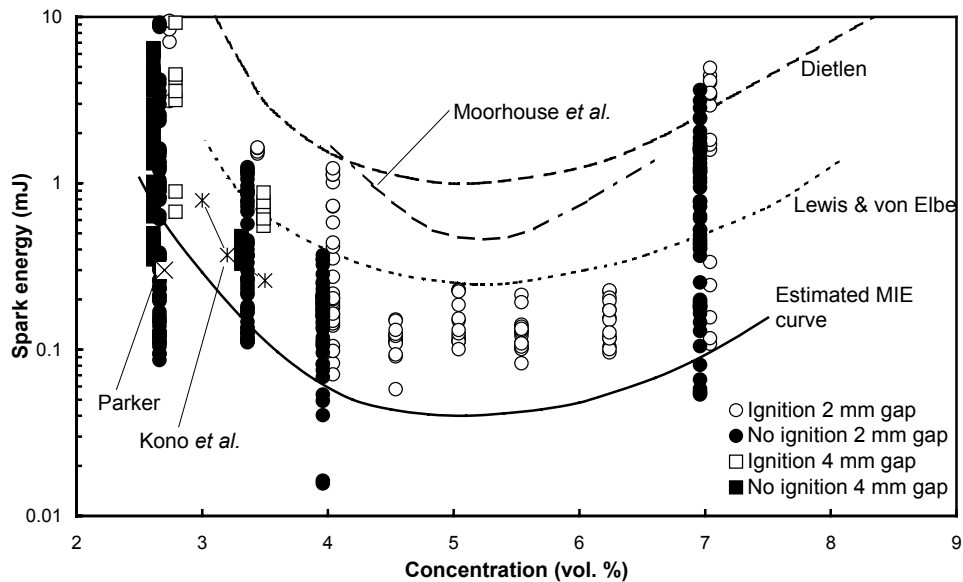

Figure 4. Minimum ignition energies for propane/air mixtures as a function of propane concentration. The white data points indicate ignition and the black no ignition, with 2 mm electrode gap represented as circles and 4 mm gap as squares. The solid line is an estimated MIE. Literature values are added [5, 11-14].

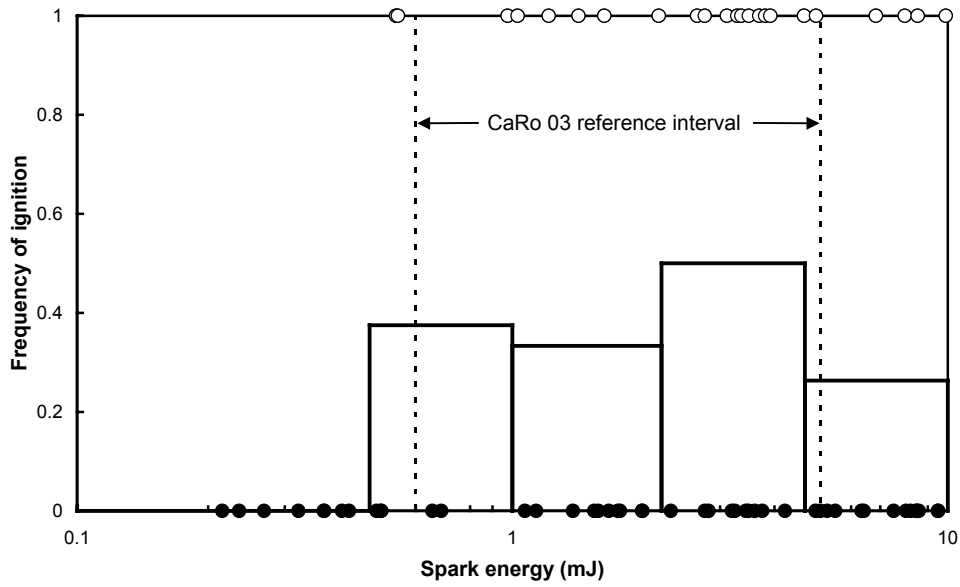

Figure 5. Frequency of ignition for niacin dust used in CaRo 03 calibration tests [17]. Ignition is indicated by white data points and no-ignition by black data points. Histograms are added, indicating the frequency of ignition within the energy levels.

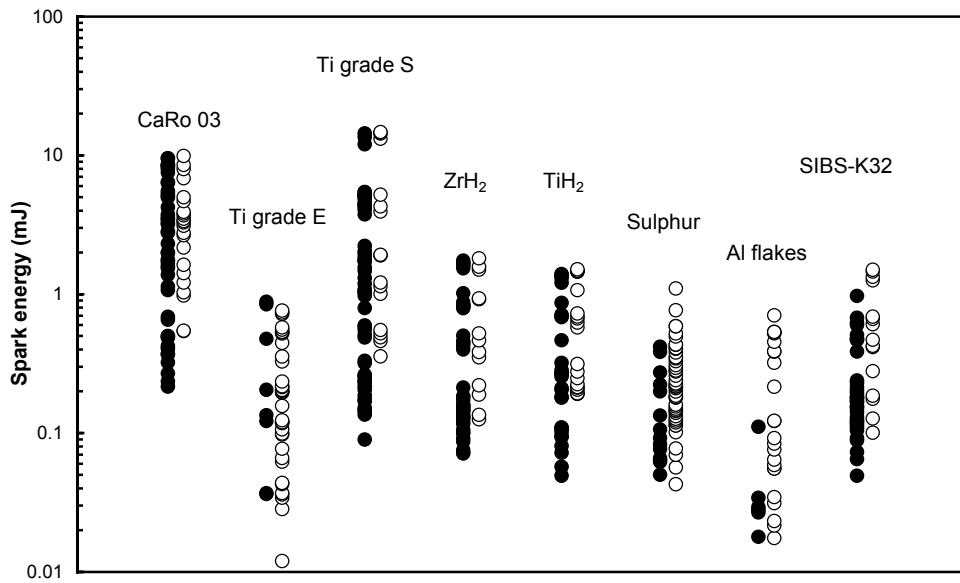

Figure 6. Spark ignition energies for various dusts in air, indicating the frequency of ignition as a function of spark energy. The white data points indicate ignition and the black no ignition.